

SERVICE

Modell

250/300/360 E-XC '97

Kabelstrangnummer

vorne 546 11 275 200
hinten 583 11 276 000

Land

S,SF,E,NL,GB,P,
BRD,CH,I,DIV

Datum, Name

24 05 95 KE

Zeichnungsnr

50
22C7-DIV

Änderungsstand

Kabelstrangbez

vo 250/300 E-XC 111 93
hi ACERBIS 93 0 BL

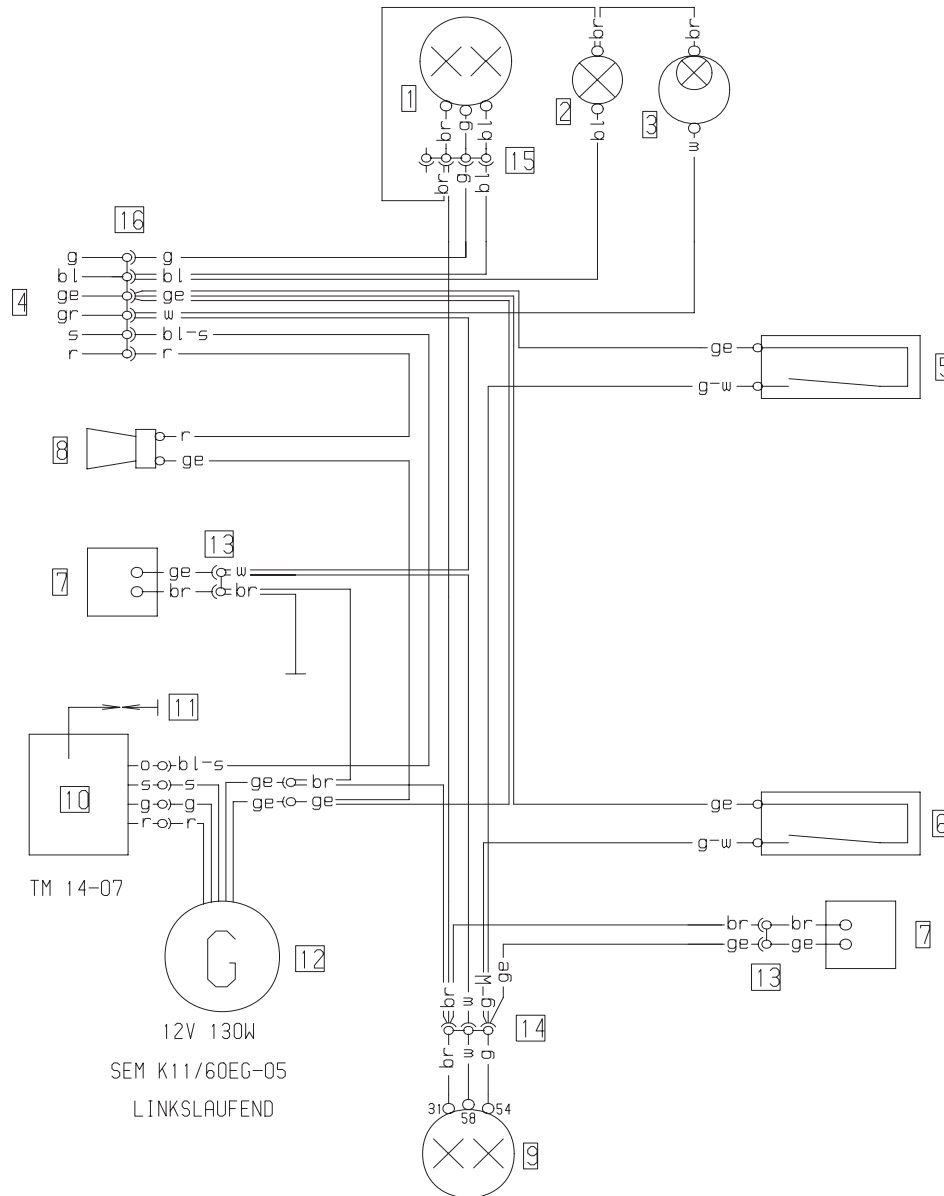

Deutsch	Englisch	Italienisch	Französisch
1 Scheinwerfer	1 headlight	1 faro	1 phare
2 Fernlichtkontrolle	2 high beam indicator	2 spia abbagliante	2 témoin feu route
3 Tachobeleuchtung	3 speedometer light	3 luce tachimetro	3 éclair comp vitesse
4 zum Kombischalter	4 to combinat switch	4 multicomando	4 commodo
5 Bremslichtsch vo	5 stoplight switch f	5 int luce arresto ant	5 contact de stop av
6 Bremslichtsch hi	6 stoplight switch r	6 int luce arresto post	6 contact de stop arr
7 Spannungsbegrenzer	7 voltage limiter	7 regol di tens	7 regulateur
8 Schnarre	8 horn	8 clacson	8 klaxon
9 Brems-Schlußlicht	9 rear-stoplight	9 fanal post di freno	9 feu arr et de stop
10 Zündspule	10 ignition coil	10 bobina d'accens	10 bobine d'allumage
11 Zündkerze	11 spark plug	11 candela	11 bougie
12 Generator	12 generator	12 dinamo	12 generateur
13 2-pol Stecker	13 multip cont plug (2)	13 connettore a 2 poli	13 connect multiple (2)
14 3-pol Stecker	14 multip cont plug (3)	14 connettore a 3 poli	14 connect multiple (3)
15 4-pol Stecker	15 multip cont plug (4)	15 connettore a 4 poli	15 connect multiple (4)
16 9-pol Stecker	16 multip cont plug (9)	16 connettore a 9 poli	16 connect multiple (9)
bl blau	bl blue	bl blu	bl bleu
br braun	br brown	br marrone	br brun
ge gelb	ge yellow	ge giallo	ge jaune
gr grau	gr grey	gr grigio	gr gris
g grün	g green	g verde	g vert
o orange	o orange	o arancione	o orange
r rot	r red	r rosso	r rouge
s schwarz	s black	s nero	s noir
v violett	v violet	v violetto	v violet
w weiß	w white	w bianco	w blanc

Kontaktbelegung -
Lichtschalter (Typ CEV 9607)

	g	bl	ge	gr	s	r	⊥
LIHT							
Abblendl	•	•	•				
Fernlicht		•	•	•			
HUPE						•	•
ZÜNDUNG AUS					•	•	
	5	2	1	3	6	4	THORN

Spanisch
1 fero
2 control luces largas
3 luz tacometro
4 llave combinada
5 interr. luces de freno del
6 interr. luces de freno tras
7 regulador de tension
8 claxon
9 luz freno tras
10 bobina de encendido
11 bujia
12 generador
13 conector multiple (2)
14 conector multiple (3)
15 conector multiple (4)
16 conector multiple (9)
bl azul
br marron
ge amarillo
gr gris
g verde
o naranja
r rojo
s negro
v violeta
w blanco

SERVICE

Model l

250/300/360 E-XC '97

Kabelstrangnummer
vorne 547 11 075 000
hinten 547 11 076 000

Land
USA, AUS, SA

Datum, Name
30 05 96 KE

Zeichnungsnr
22C7-USA

Änderungsstand

Kabelstrangbez
vo 250/300 E-XC I
hi ACERBIS 93 0 BL

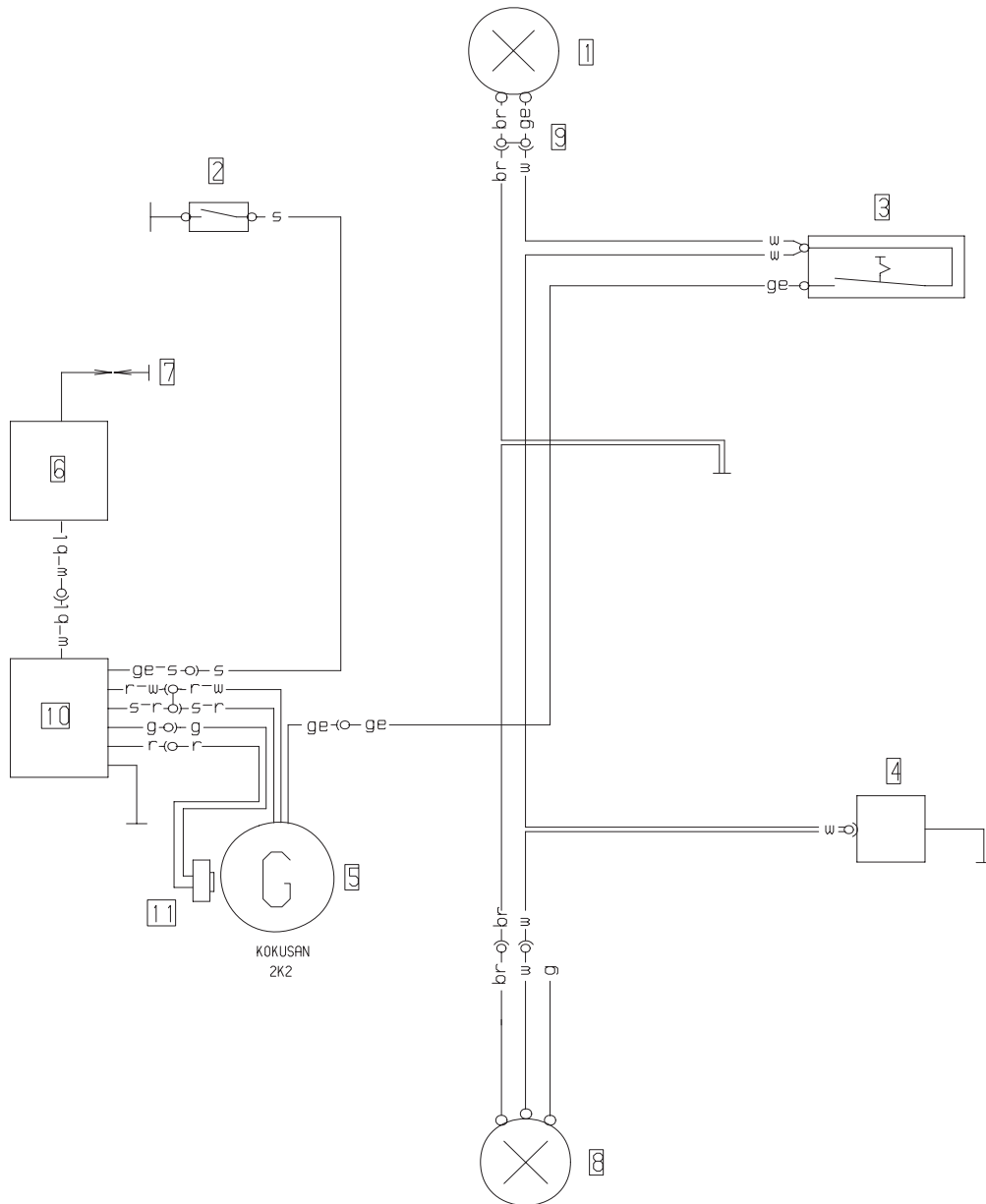

Deutsch	Englisch	Italianisch	Französisch
1 Scheinwerfer	1 headlight	1 faro	1 phare
2 Kurzschlußtaster	2 short-circuit button	2 interr cortocircuito	2 bouton d'arret
3 Lichtschalter	3 light switch	3 interr dello luce	3 interr d'eclairage
4 Spannungsbegrenzer	4 voltage limiter	4 regol di tens	4 regulateur
5 Generator	5 generator	5 dinamo	5 generateur
6 Zündspule	6 ignition coil	6 bobina d'accens	6 bobine d'allumage
7 Zündkerze	7 spark plug	7 candela	7 bougie
8 Schlußlicht	8 rearlight	8 fanale posteriore	8 feu arriere
9 2-pol Stecker	9 multip cont plug (2)	9 connettore a 2 poli	9 connect multiple (2)
10 CDI-Einheit	10 CDI-unit	10 CDI-seatola	10 CDI-unite
11 Impulsgeber	11 pulser coil	11 distributore	11 generateur d'impuls
bl blau	bl blue	bl blu	bl bleu
br braun	br brown	br marrone	br brun
ge gelb	ge yellow	ge giallo	ge jaune
gr grau	gr grey	gr grigio	gr gris
g grün	g green	g verde	g vert
o orange	o orange	o arancione	o orange
r rot	r red	r rosso	r rouge
s schwarz	s black	s nero	s noir
v violett	v violet	v violetto	v violet
w weiß	w white	w bianco	w blanc

SERVICE

Modell

250/300/360 E-GS '97

Kabelstrangnummer

vorne 546 11 475 200
hinten 546 11 476 200

Land

A,CH

Datum, Name

02 05 95 KE

Zeichnungsnr

51
2257MB--

Änderungsstand

Kabelstrangbez

vo 250/300/360 GS
hi Ulo 93 m Blinker

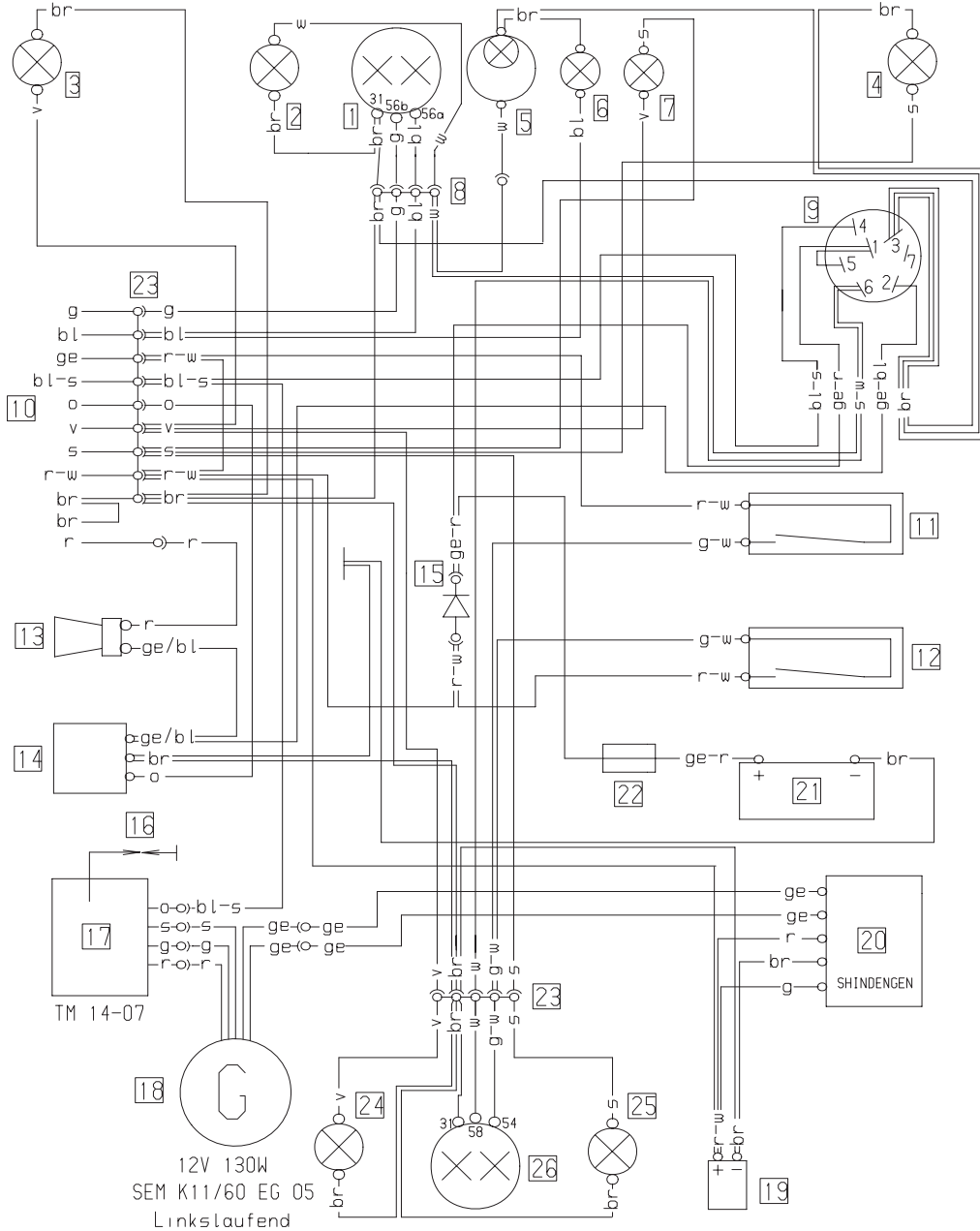

Deutsch	Englisch	Italienisch	Französisch
1 Scheinwerfer	1 headlight	1 fano	1 phare
2 Standlicht	2 parking light	2 luce di posizione	2 feu de position
3 Blinker li vo	3 turn indic left fr	3 lampegg ant sn	3 clignoteur av gauche
4 Blinker re vo	4 turn indic right fr	4 lampegg ant dx	4 clignoteur av droit
5 Tachobeuchtung	5 speedometer light	5 luce di tachimetro	5 éclair comp vitesse
6 Fernlichtkontrolle	6 high beam indicator	6 spia abbagliante	6 témoin feu route
7 Blinkerkontrolle	7 turn indicator	7 spia lampeggiatori	7 témoin de clignoteur
8 4-pol Stecker	8 multip cont plug (4)	8 connettore a 4 poli	8 connect multiple (4)
9 Zündschloß	9 ignition lock	9 accensione	9 contact d'allum
10 zum Kombischalter	10 to combinat switch	10 multicomando	10 commodo
11 Bremslichtsch vo	11 stoplight switch f	11 int luce arresto ant	11 contact de stop av
12 Bremslichtsch hi	12 stoplight switch r	12 int luce arresto post	12 contact Harr de stop
13 Horn	13 horn	13 clacson	13 klaxon
14 Blinkgeber	14 turn indicator	14 trasmett di lampeg	14 centrale clignet
15 Diode	15 diode	15 diodo	15 pont
16 Zündkerze	16 spark plug	16 candela	16 bougie
17 Zündspule	17 ignition coil	17 bobina d'accens	17 bobine d'allumage
18 Generator	18 generator	18 dinamo	18 generateur
19 Kondensator	19 capacitor	19 condensatore	19 condensateur
20 Spannungsregler	20 voltage regulator	20 regol di tens	20 regulateur
21 Batterie 1 2Ah	21 battery 1 2Ah	21 batteria 1 2Ah	21 batterie 1 2Ah
22 Stecksicherung 10A	22 fuse 10A	22 fusibile 10A	22 fusible 10A
23 9-pol Stecker	23 multip cont plug (9)	23 connettore a 9 poli	23 connect multiple (9)
24 Blinker li hi	24 blinker left rear	24 lampegg post sn	24 clign arr gauche
25 Blinker re hi	25 blinker right rear	25 lampegg post dx	25 clign arr droite
26 Brems-Schlußlicht	26 rear-stoplight	26 fanal post di freno	26 feu arr et de stop

bl blau	bl blue	bl blu	bl bleu
br braun	br brown	br marrone	br brun
ge gelb	ge yellow	ge giallo	ge jaune
gr grau	gr grey	gr grigio	gr gris
g grün	g green	g verde	g vert
o orange	o orange	o arancione	o orange
r rot	r red	r rosso	r rouge
s schwarz	s black	s nero	s noir
v violett	v violet	v violetto	v violet
w weiß	w white	w bianco	w blanche

Kontaktbelegung
Kombischalter (Typ Merit)

	ge	g	bl	r-w	s	o	v	s-bl	br	r	br
LIGHT HI	●	●									
LO	●										
FL			●								
TURN L					●	●					
TURN R					●	●					
HORN										●	●
STOP									●		
	1	2	3	4	8	9	10	11	12	13	14

Kontaktbelegung
Zündschloß (Typ CEV 7-pol)

	1	2	3	4	5	6	7
PARK	●		●	●		●	
AUS			●	●			
EIN	●	●			●	●	
EIN	●	●			●	●	

12V 130W
SEM K11/60 EG 05
Linkslaufend

SERVICE

Modell

250/300/360 E-GS '97

Kabelstrangnummer

vorne 546 11 475 200
hinten 546 11 476 200

Land

DIVERSE

Datum, Name

02 05 95 KE

Zeichnungsnr

51
22570B--

Änderungsstand

Kabelstrangbez

vo 250/300/360 GS
hi Ulo 93 m Blinker

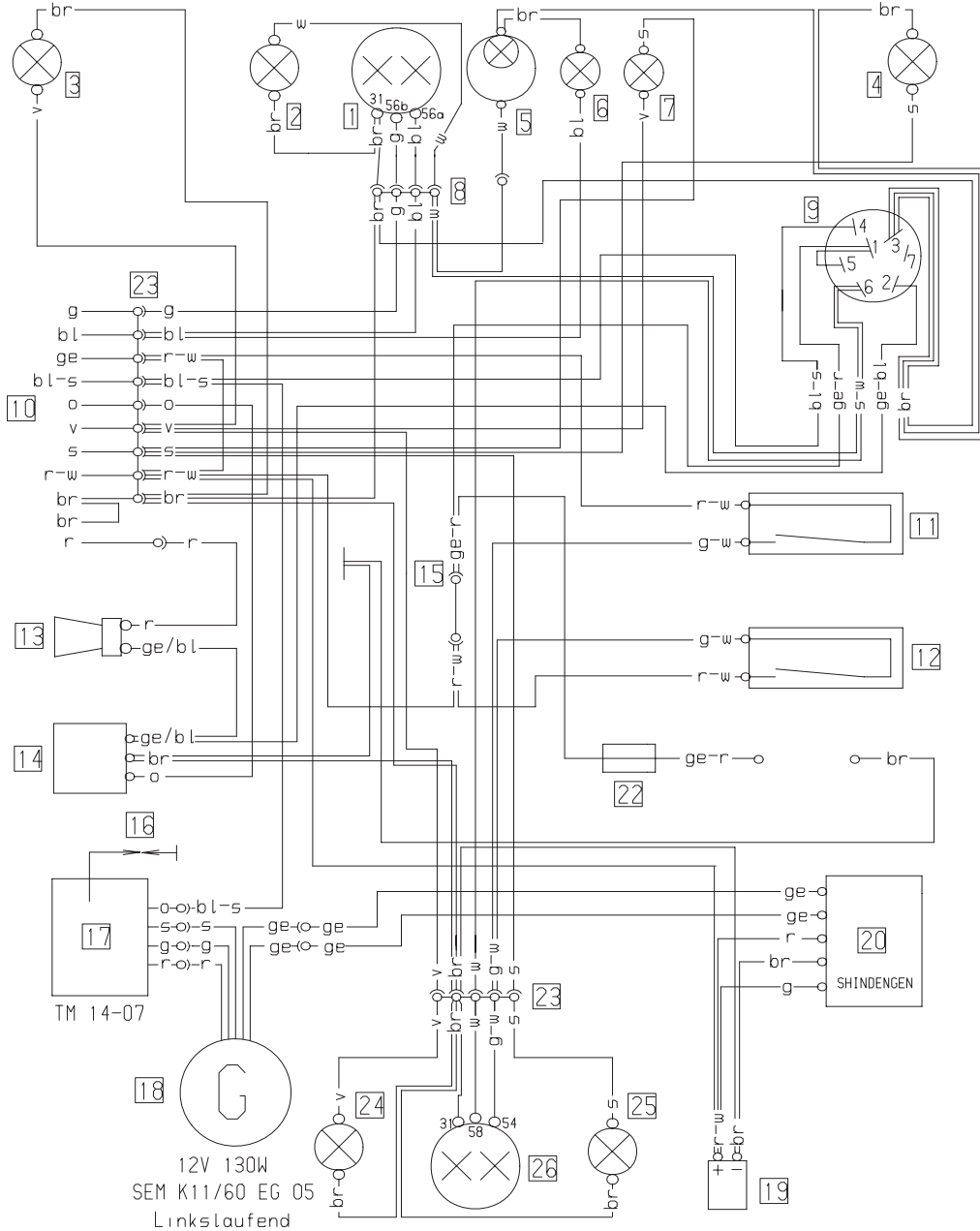

Deutsch	Englisch	Italienisch	Französisch
1 Scheinwerfer	1 headlight	1 fano	1 phare
2 Standlicht	2 parking light	2 luce di posizione	2 feu de position
3 Blinker li vo	3 turn indic left fr	3 lampegg ant sn	3 clignoteur av gauche
4 Blinker re vo	4 turn indic right fr	4 lampegg ant dx	4 clignoteur av droit
5 Tachobeleuchtung	5 speedometer light	5 luce di tachimetro	5 éclair comp vitesse
6 Fernlichtkontrolle	6 high beam indicator	6 spia abbagliante	6 témoin feu route
7 Blinkerkontrolle	7 turn indicator	7 spia lampeggiatori	7 témoin de clignoteur
8 4-pol Stecker	8 multip cont plug (4)	8 connettore a 4 poli	8 connect multiple (4)
9 Zündschloß	9 ignition lock	9 accensione	9 contact d'allum
10 zum Kombischalter	10 to combinat switch	10 multicomando	10 commodo
11 Bremslichtsch vo	11 stoplight switch f	11 int luce arresto ant	11 contact de stop av
12 Bremslichtsch hi	12 stoplight switch r	12 int luce arresto post	12 contact Harr de stop
13 Horn	13 horn	13 clacson	13 klaxon
14 Blinkgeber	14 turn indicator	14 trasmett di lampeg	14 centrale clignet
15 Kabelbrücke	15 wirebridge	15 ponte	15 pont
16 Zündkerze	16 spark plug	16 candela	16 bougie
17 Zündspule	17 ignition coil	17 bobina d'accens	17 bobine d'allumage
18 Generator	18 generator	18 dinamo	18 generateur
19 Kondensator	19 capacitor	19 condensatore	19 condensateur
20 Spannungsregler	20 voltage regulator	20 regol di tens	20 regulateur
21 Batterie 1 2Ah	21 battery 1 2Ah	21 batteria 1 2Ah	21 batterie 1 2Ah
22 Stecksicherung 10A	22 fuse 10A	22 fusibile 10A	22 fusible 10A
23 9-pol Stecker	23 multip cont plug (9)	23 connettore a 9 poli	23 connect multiple (9)
24 Blinker li hi	24 blinker left rear	24 lampegg post sn	24 clign arr gauche
25 Blinker re hi	25 blinker right rear	25 lampegg post dx	25 clign arr droite
26 Brems-Schlußlicht	26 rear-stoplight	26 fanal post di freno	26 feu arr et de stop

bl blau	bl blue	bl blu	bl bleu
br braun	br brown	br marrone	br brun
ge gelb	ge yellow	ge giallo	ge jaune
gr grau	gr grey	gr grigio	gr gris
g grün	g green	g verde	g vert
o orange	o orange	o arancione	o orange
r rot	r red	r rosso	r rouge
s schwarz	s black	s nero	s noir
v violett	v violet	v violetto	v violet
w weiß	w white	w bianco	w blanc

Kontaktbelegung
Zündschloß (Typ CEV 7-pol)

	1	2	3	4	5	6	7
PARK	•		•	•			
AUS			•				
EIN	•				•	•	
EIN	•				•		

Kontaktbelegung
Kombischalter (Typ Merit)

	ge	g	bl	r-w	s	o	v	s-bl	br	r	br
LIGHT HI	•	•									
LO	•										
FL			•								
TURN L					•	•					
TURN R					•	•					
HORN										•	•
STOP									•		
	1	2	3	4	8	9	10	11	12	13	14

SERVICE

Modell

250/300/360 E-GS '97

Kabelstrangnummer

vorne 546 11 475 200
hinten 546 11 476 200

Land

AUS

Datum, Name

02 05 95 KE

Zeichnungsnr

51
2257MBA-

Änderungsstand

Kabelstrangbez

vo 250/300/360 GS
hi Ulo 93 m Blinker

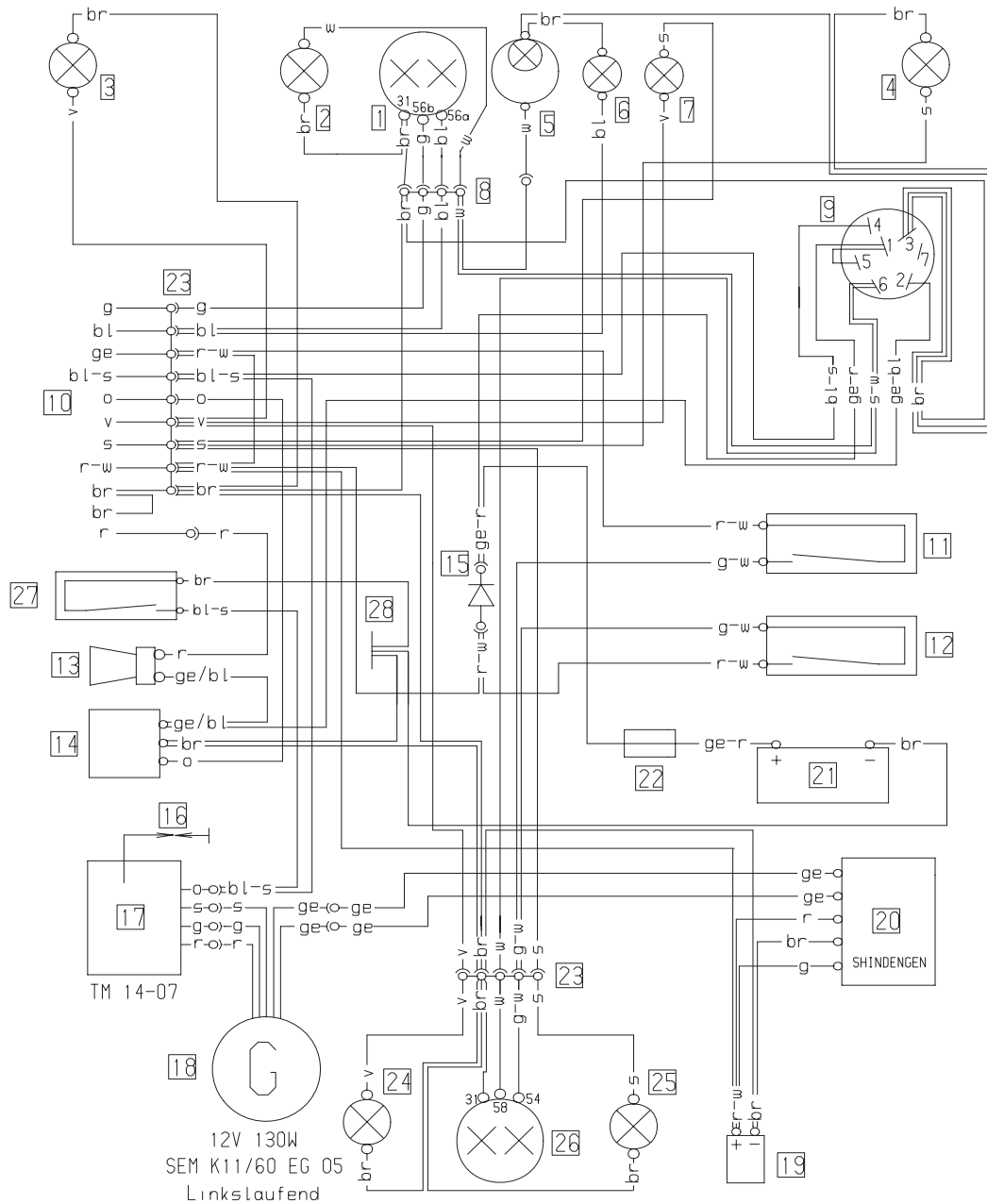

Deutsch	Englisch	Italienisch	Französisch
1 Scheinwerfer	1 headlight	1 fano	1 phare
2 Standlicht	2 parking light	2 luce di posizione	2 feu de position
3 Blinker li vo	3 turn indic left fr	3 lampegg ant sn	3 clignoteur av gauche
4 Blinker re vo	4 turn indic right fr	4 lampegg ant dx	4 clignoteur av droit
5 Tachobeuchtung	5 speedometer light	5 luce di tachometro	5 éclair comp vitesse
6 Fernlichtkontrolle	6 high beam indicator	6 spia abbagliante	6 témoin feu route
7 Blinkerkontrolle	7 turn indicator	7 spia lampeggiatori	7 témoin de clignoteur
8 4-pol Stecker	8 multip cont plug (4)	8 connettore a 4 poli	8 connect multiple (4)
9 Zündschloß	9 ignition lock	9 accensione	9 contact d'allum
10 zum Kombischalter	10 to combinat switch	10 multicomando	10 commodo
11 Bremslichtsch vo	11 stoplight switch f	11 int luce arresto ant	11 contact de stop av
12 Bremslichtsch hi	12 stoplight switch r	12 int luce arresto post	12 contact Harr de stop
13 Horn	13 horn	13 clacson	13 klaxon
14 Blinkgeber	14 turn indicator	14 trasmett di lampeg	14 centrale clignet
15 Diode	15 diode	15 diodo	15 pont
16 Zündkerze	16 spark plug	16 candela	16 bougie
17 Zündspule	17 ignition coil	17 bobina d'accens	17 bobine d'allumage
18 Generator	18 generator	18 dinamo	18 generateur
19 Kondensator	19 capacitor	19 condensatore	19 condensateur
20 Spannungsregler	20 voltage regulator	20 regol di tens	20 regulateur
21 Batterie 1 2Ah	21 battery 1 2Ah	21 batteria 1 2Ah	21 batterie 1 2Ah
22 Stecksicherung 10A	22 fuse 10A	22 fusibile 10A	22 fusible 10A
23 9-pol Stecker	23 multip cont plug (9)	23 connettore a 9 poli	23 connect multiple (9)
24 Blinker li hi	24 blinker left rear	24 lampegg post sn	24 clign arr gauche
25 Blinker re hi	25 blinker right rear	25 lampegg post dx	25 clign arr droite
26 Brems-Schlußlicht	26 rear-stoplight	26 fanal post di freno	26 feu arr et de stop
27 Not-Ausschalter	27 run-off switch	27 disinseritor	27 bouton de demarage
28 Masseanschluß	28 ground connection	28 collegam a massa	28 masse

bl blau	bl blue	bl blu	bl bleu
br braun	br brown	br marrone	br brun
ge gelb	ge yellow	ge giallo	ge jaune
gr grau	gr grey	gr grigio	gr gris
g grün	g green	g verde	g vert
o orange	o orange	o arancione	o orange
r rot	r red	r rosso	r rouge
s schwarz	s black	s nero	s noir
v violett	v violet	v violetto	v violet
w weiß	w white	w bianco	w blanc

Kontaktbelegung
Kombischalter (Typ Merit)

	ge	g	bl	r-w	s	o	v	s-bl	br	r	br
LIGHT HI	●	●									
LO	●										
FL		●									
TURN L					●	●					
TURN R					●	●					
HORN										●	
STOP								●			
	1	2	3	4	8	9	10	11	12	13	14

Kontaktbelegung
Zündschloß (Typ CEV 7-pol)

	1	2	3	4	5	6	7
PARK	●		●	●			
AUS			●	●			
EIN	●				●	●	
EIN	●				●	●	

SERVICE

Model l

250/300/360 E-XC '97

Kabelstrangnummer
vorne 547 11 075 000
hinten 547 11 076 000

Land
USA, AUS, SA

Datum, Name
30 05 96 KE

Zeichnungsnr
22C7-USA

Änderungsstand

Kabelstrangbez
vo 250/300 E-XC I
hi ACERBIS 93 0 BL

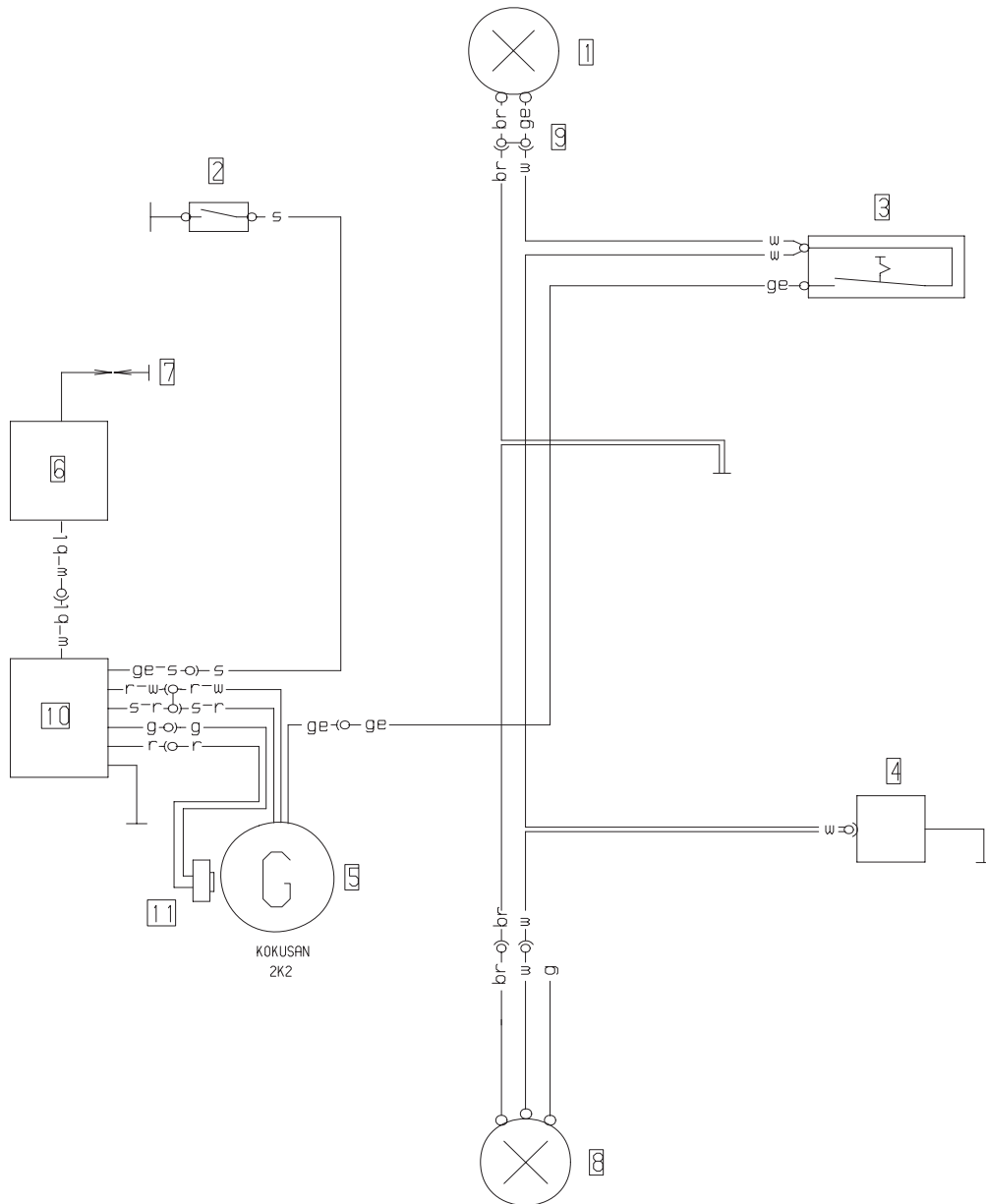

Deutsch	Englisch	Italianisch	Französisch
1 Scheinwerfer	1 headlight	1 faro	1 phare
2 Kurzschlußtaster	2 short-circuit button	2 interr cortocircuito	2 bouton d'arret
3 Lichtschalter	3 light switch	3 interr dello luce	3 interr d'eclairage
4 Spannungsbegrenzer	4 voltage limiter	4 regol di tens	4 regulateur
5 Generator	5 generator	5 dinamo	5 generateur
6 Zündspule	6 ignition coil	6 bobina d'accens	6 bobine d'allumage
7 Zündkerze	7 spark plug	7 candela	7 bougie
8 Schlußlicht	8 rearlight	8 fanale posteriore	8 feu arriere
9 2-pol Stecker	9 multip cont plug (2)	9 connettore a 2 poli	9 connect multiple (2)
10 CDI-Einheit	10 CDI-unit	10 CDI-seatola	10 CDI-unite
11 Impulsgeber	11 pulser coil	11 distributore	11 generateur d'impuls
bl blau	bl blue	bl blu	bl bleu
br braun	br brown	br marrone	br brun
ge gelb	ge yellow	ge giallo	ge jaune
gr grau	gr grey	gr grigio	gr gris
g grün	g green	g verde	g vert
o orange	o orange	o arancione	o orange
r rot	r red	r rosso	r rouge
s schwarz	s black	s nero	s noir
v violett	v violet	v violetto	v violet
w weiß	w white	w bianco	w blanc