

Deutsch	Englisch	Italienisch	Französisch
1 Scheinwerfer	1 headlight	1 faro	1 phare
2 Stecksicherung 10A	2 fuse 10 A	2 fusibile 10A	2 fusible 10A
3 Lichtschalter	3 light switch	3 interr della luce	3 interr d' eclairage
4 Spannungsbegrenzer	4 voltage limiter	4 regol di tens	4 regulateur
5 Generator	5 generator	5 dinamo	5 generateur
6 Zündspule	6 ignition coil	6 bobina d'accens	6 bobine d'allumage
7 Zündkerze	7 spark plug	7 candela	7 bougie
8 Schlußlicht	8 rearlight	8 fanale posteriore	8 feu arriere
9 3-pol Stecker	9 multip cont plug (3)	9 connettore a 3 poli	9 connect multiple (3)
10 CDI-Einheit	10 CDI-unit	10 CDI-seatola	10 CDI-unite
11 Startrelais	11 starter relay	11 rele d'avviamento	11 relais de demarreur
12 4-pol Stecker	12 multip cont plug (4)	12 connettore a 4 poli	12 connect multiple (4)
13 Start/Not Aus	13 startsw /run off	13 disinteritor/partire	13 ba de dem/arr d'urg
14 Startermotor	14 starter engine	14 mot d'avviamento	14 demarreur electrique
15 Batterie 12V 4Ah	15 battery 12V 4Ah	15 batteria 12V 4Ah	15 batterie 12V 4Ah
16 Lüfteranschluss	16 fan connection	16 connett ventilatore	16 connect ventilateur
17 Impulsgeber	17 pulser coil	17 trasmett d'impulsi	17 generateur d'impuls
18 2-pol Stecker	18 multip cont plug (2)	18 connettore a 2 poli	18 connect multiple (2)

bl blau	bl blue	bl blu	bl bleu
br braun	br brown	br marrone	br brun
ge gelb	ge yellow	ge giallo	ge jaune
gr grau	gr grey	gr grigio	gr gris
g grün	g green	g verde	g vert
o orange	o orange	o arancione	o orange
r rot	r red	r rosso	r rouge
s schwarz	s black	s nero	s noir
v violett	v violet	v violetto	v violet
w weiß	w white	w bianco	w blanc

Start- Notaus- Schalter

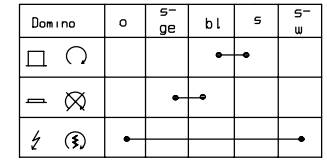

Spanisch	
1 faro	
2 fusible prin 10A	
3 interruptor d'luz	
4 regulador de tension	
5 generador	
6 bobina de encendido	
7 bujia	
8 luz de trasera	
9 conect multiple (3)	
10 unidad cdi	
11 rele de arranque	
12 conect multiple (4)	
13 bott de arr par de u	
14 motor de arranque	
15 batteria 12V 4Ah	
16 conector ventilador	
17 generador de tension	
18 conector multiple(2)	

bl azul	
br marron	
ge amarillo	
gr gris	
g verde	
o naranja	
r rojo	
s negro	
v violeta	
w blanco	

MXC without lights

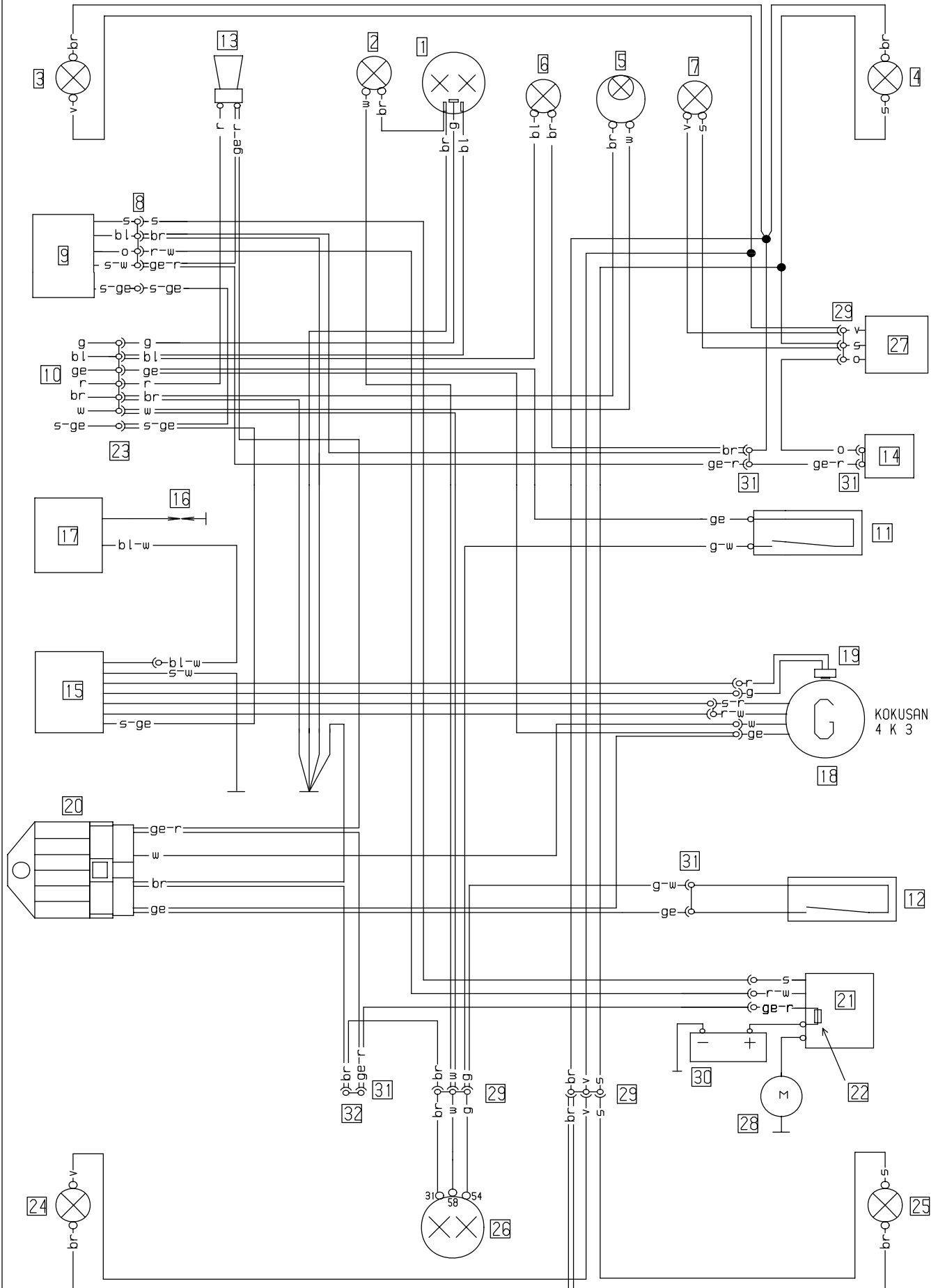

400/520 EXC RACING 01/02 EU, AUS

Deutsch	Englisch	Italienisch	Französisch
1 Scheinwerfer	1 headlight	1 faro	1 phare
2 Standlicht	2 position light	2 luce di posizione	2 feu de position
3 Blinker li vo	3 turn indic left fr	3 lampegg ant sn	3 clignoteur av gauche
4 Blinker re vo	4 turn indic right fr	4 lampegg ant dx	4 clignoteur av droit
5 Tachobeleuchtung	5 speedometer light	5 luce di tachimetro	5 éclair comp vitesse
6 Fernlichtkontrolle	6 high beam indicator	6 spia abbagliante	6 témoin feu route
7 Blinkerkontrolle	7 turn indicator	7 spia lampeggiatori	7 témoin de clignoteur
8 4-pol Stecker	8 multip cont plug (4)	8 connettore a 4 poli	8 connect multiple (4)
9 Start / Not Aus	9 startsw /run-off	9 disinteritor/partire	9 ba de dem /arr d'urg
10 zum Kombischalter	10 to combinat switch	10 multicomando	10 commodo
11 Bremslichtsch vo	11 stoplight switch f	11 int luce arresto ant	11 contact de stop av
12 Bremslichtsch hi	12 stoplight switch r	12 int luce arresto post	12 contact Harr de stop
13 Horn	13 horn	13 clacson	13 klaxon
14 Blinkgeber	14 turn indicator	14 trasmett di lampeg	14 centrale clignot
15 CDI-Einheit	15 CDI-unit	15 CDI-seatola	15 boitier CDI
16 Zündkerze	16 spark plug	16 candela	16 bougie
17 Zündspule	17 ignition coil	17 bobina d'accens	17 bobine d'allumage
18 Generator	18 generator	18 dinamo	18 generateur
19 Impulsgeber	19 pulser coil	19 trasmett d'impulsi	19 generateur d'impuls
20 Spannungsregler	20 voltage regulator	20 regol di tens	20 regulateur
21 Startrelais	21 starter relay	21 rele d'avviamento	21 relais de demarreur
22 Stecksicherung 10A	22 fuse 10A	22 fusibile 10A	22 fusible 10A
23 6-pol Stecker	23 multip cont plug (6)	23 connettore a 6 poli	23 connect multiple (6)
24 Blinker li hi	24 blinker left rear	24 lampegg post sn	24 clign arr gauche
25 Blinker re hi	25 blinker right rear	25 lampegg post dx	25 clign arr droite
26 Brems-Schlußlicht	26 rear-stoplight	26 fanal post di freno	26 feu arr et de stop
27 Blinkerschalter	27 blink switch	27 int lampeggiatori	27 contact d clignoteur
28 Startermotor	28 starter engine	28 mot d'avviamento	28 demrreur electrique
29 3-pol Stecker	29 multip cont plug (3)	29 connettore a 3 poli	29 connect multiple (3)
30 Batterie 12V 4Ah	30 battery 12V 4Ah	30 batteria 12V 4Ah	30 batterie 12V 4Ah
31 2-pol Stecker	31 multip cont plug (2)	31 connettore a 2 poli	31 connect multiple (2)
32 Lüfteranschluss	32 fan connection	32 connett ventilatore	32 connect ventilateur

Deutsch	Englisch	Italienisch	Französisch	Spanisch
bl blau	bl blue	bl blu	bl bleu	bl azul
br braun	br brown	br marrone	br brun	br marron
ge gelb	ge yellow	ge giallo	ge jaune	ge amarillo
gr grau	gr grey	gr grigio	gr gris	gr gris
g grün	g green	g verde	g vert	g verde
o orange	o orange	o arancione	o orange	o naranja
r rot	r red	r rosso	r rouge	r rojo
s schwarz	s black	s nero	s noir	s negro
v violett	v violet	v violetto	v violet	v violeta
w weiß	w white	w bianco	w blanc	w blanco

Spanisch
1 faro
2 luz de posicion
3 interm izquierdo delantero
4 intermitente derecho delantero
5 luz tacometro
6 lampara aviso luces largas
7 lampara aviso intermitentes
8 conector multiple (4)
9 boton de arr par de urg
10 interruptor combinado
11 interr luz de freno del
12 interr luz de fren tras
13 claxon
14 conjunto del intermintente
15 unidad cdi
16 bujia
17 bobina de encendido
18 generador
19 generado de impulsos
20 regulador de tension
21 rele de arranque
22 fusible principal 10A
23 conector multiple (6)
24 intermitente izquierdo trasero
25 intermitente derecho trasero
26 luz de freno trasero
27 interruptor clignoteur
28 motor de arranque
29 conector multiple (3)
30 batteria 12V 4Ah
31 conector multiple (2)
32 conector ventilador

Start- Notaus- Schalter

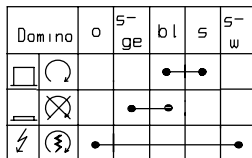

Blinkerschalter

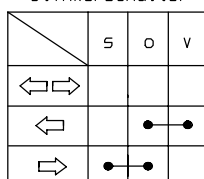

Kontaktbelegung -
Lichtschalter (Typ CEV 9610)

