



450 SX 2006



SPARE PARTS MANUAL: ENGINE

ART.NO.: 3CM089230EN

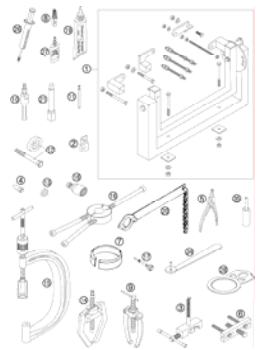
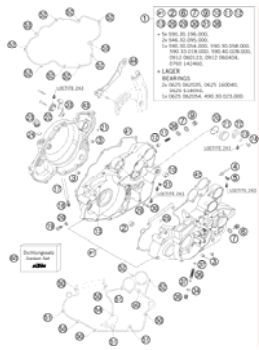
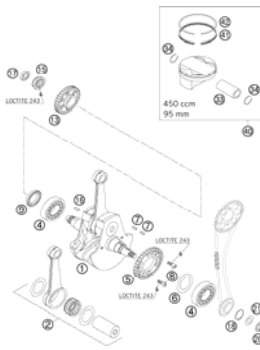
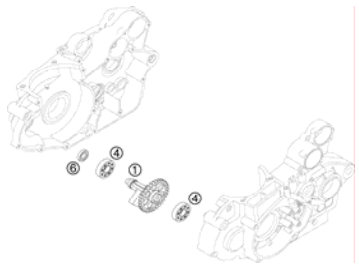
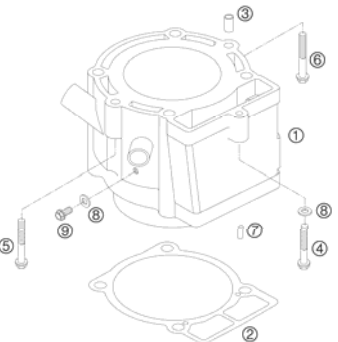
ENGLISH

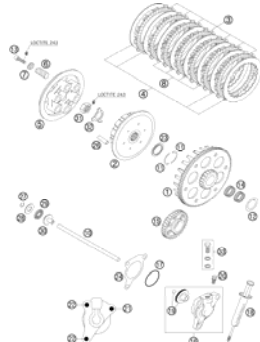
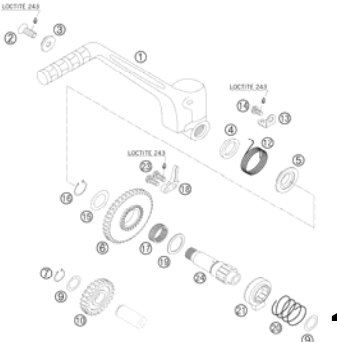
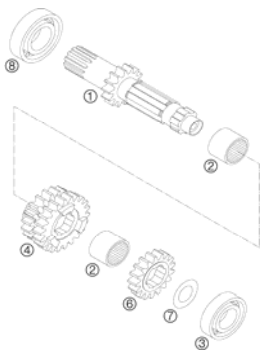
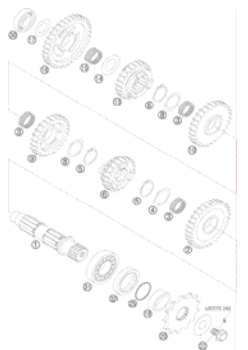
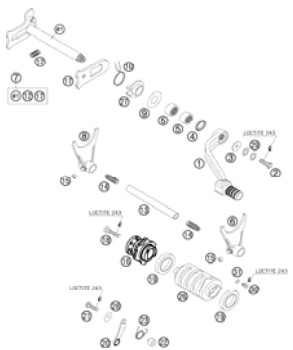
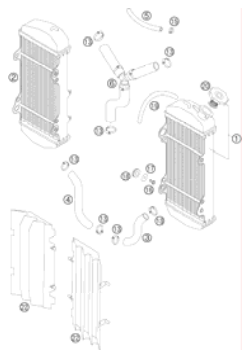

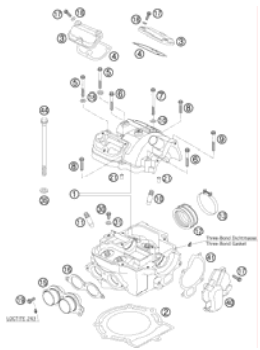
SPECIAL TOOLS  3	ENGINE CASE  4	CRANKSHAFT, PISTON  6	BALANCER SHAFT  7
CYLINDER  8	CARBURETOR  9	CLUTCH  11	KICKSTARTER  12
TRANSMISSION I  13	TRANSMISSION II  14	SHIFTING MECHANISM  15	COOLING SYSTEM  16

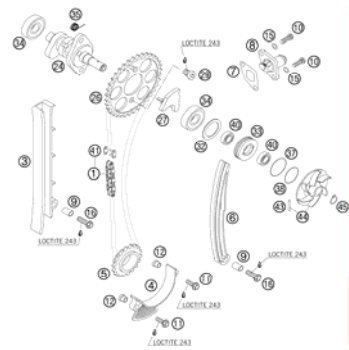
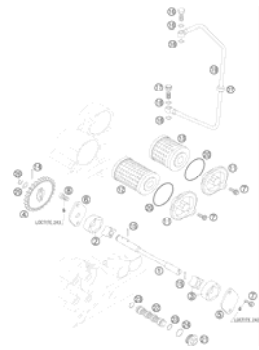
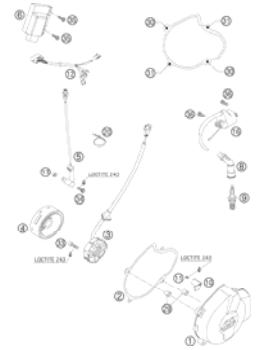
<p>CYLINDER HEAD</p>  <p>17</p>	<p>VALVE DRIVE</p>  <p>18</p>	<p>TIMING VALVE</p>  <p>19</p>	<p>LUBRICATING SYSTEM</p>  <p>20</p>
<p>IGNITION SYSTEM</p>  <p>21</p>	<div style="display: flex; align-items: center;"> <div style="background-color: #cccccc; padding: 20px; margin-right: 20px; text-align: center;"> ! </div> <div> <p>All information contained is without obligation. KTM-Sportmotorcycle AG particularly reserves the right to modify any equipment, technical specifications, prices, colors, shapes, materials, services, service work, constructions, equipment and the like so as to adapt them to local conditions or to cancel any of the above items, all without previous announcement and without giving reasons. KTM may stop manufacturing certain models without previous notice. KTM shall not be held liable for any deviations of availability and/or ability to deliver, illustrations, descriptions, printing and/or other errors. The illustrated models partly contain extra equipment, which is not applied to standard models. © 2004 by KTM-SPORTMOTORCYCLE AG, Mattighofen AUSTRIA; All rights reserved; Reprint, also in extracts, with written allowance of KTM-SPORTMOTORCYCLE AG, Mattighofen only.</p> </div> </div>		

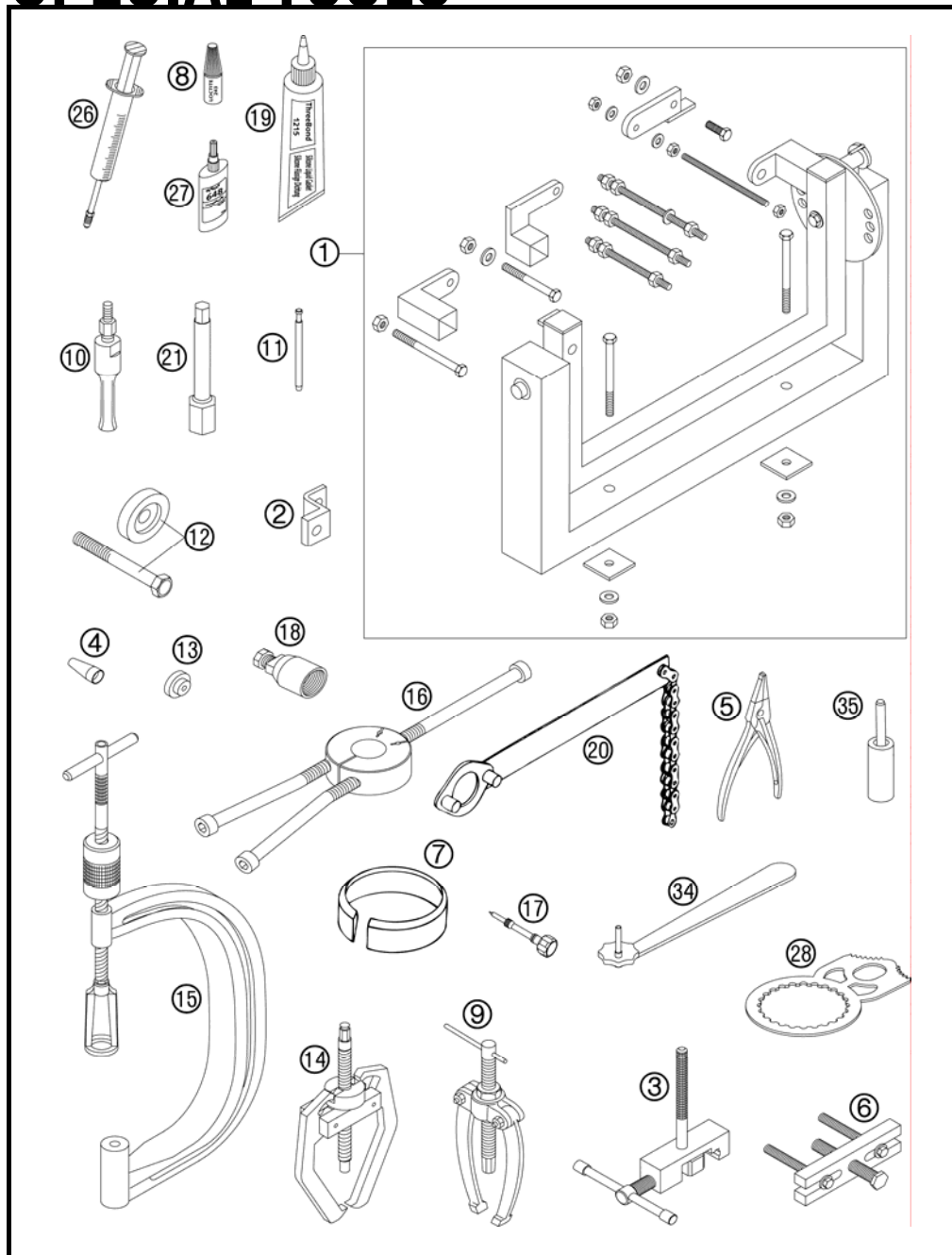

FIG	PART NUMBER	DESCRIPTION	QTY
1*	56012001044	UNIVERSAL MOUNTING RACK CPL.	1
2	59029002000	ENGINE HOLDER FOR RACING 2000	1
3	59029020000	RIVETTING TOOL TIMING CHAIN	1
4	59029005010	MOUNTING SLEEVE SEAL RING	1
5	51012011000	SPECIAL CIRCLIP PLIER	1
6	59029021044	EXTRACTOR PRIM. GEAR CPL.	1
7	58012015089	PISTON RING COMPRESSOR D=89MM	1
7	58012015095	PISTON RING COMPRESSOR D=95MM	1
7	59829015075	PISTON R. COMPRESSOR D=75MM 02	1
8	6899785	LOCTITE 243 BLUE 6CCM	1
9	15112017000	BUSHING EXTRACTOR	1
10	15112018000	INTERN.BEAR.PULLER 12-16 MM	1
10	15112018100	INTERN.BEAR.PULLER 18-23 MM	1
10	15112018200	INTERN.BEAR.PULLER 5-7 MM	1
11	59029026006	LIMIT PLUG GAUGE F.VALVE GUIDE	1
12	59029035000	MOUNTING RING FOR INNER CLUTCH	1
13	59029036000	PROTECTION COVER F.MAIN SHAFT	1
14	59029033000	EXTRACTOR FOR TIMING GEAR	1
15	59029019000	VALVE SPRING LEVER	1
16	58429037037	MOUNTING TOOL INNER RING NJ206	1
17	59031017200	MIXT. CONTROL SCREW FACTORY 04	1
18	58012009000	FLYWHEEL EXTRACTOR	1
19	309098	SILICON GASKET THREE-BOND	1
20	51012012000	HOLDING SPANNER FOR SPROCKET	1
21	59029072000	SPARK PLUG WRENCH 13/16	1
26	50329050000	VENT INJEKTION HYDR. CLUTCH	1
27	58429059000	LOCTITE 648 GREEN 24ML	1
28	59029003100	CLUTCH HOLDER RACING 2004	1
34	59029034000	WRENCH F.MIXTURE CONTROL SCREW	1
35*	59029018000	PRESS PUNCH VALVE GUIDE	1

065902900 / C065902900

* NEW PART

X AS REQUIRED

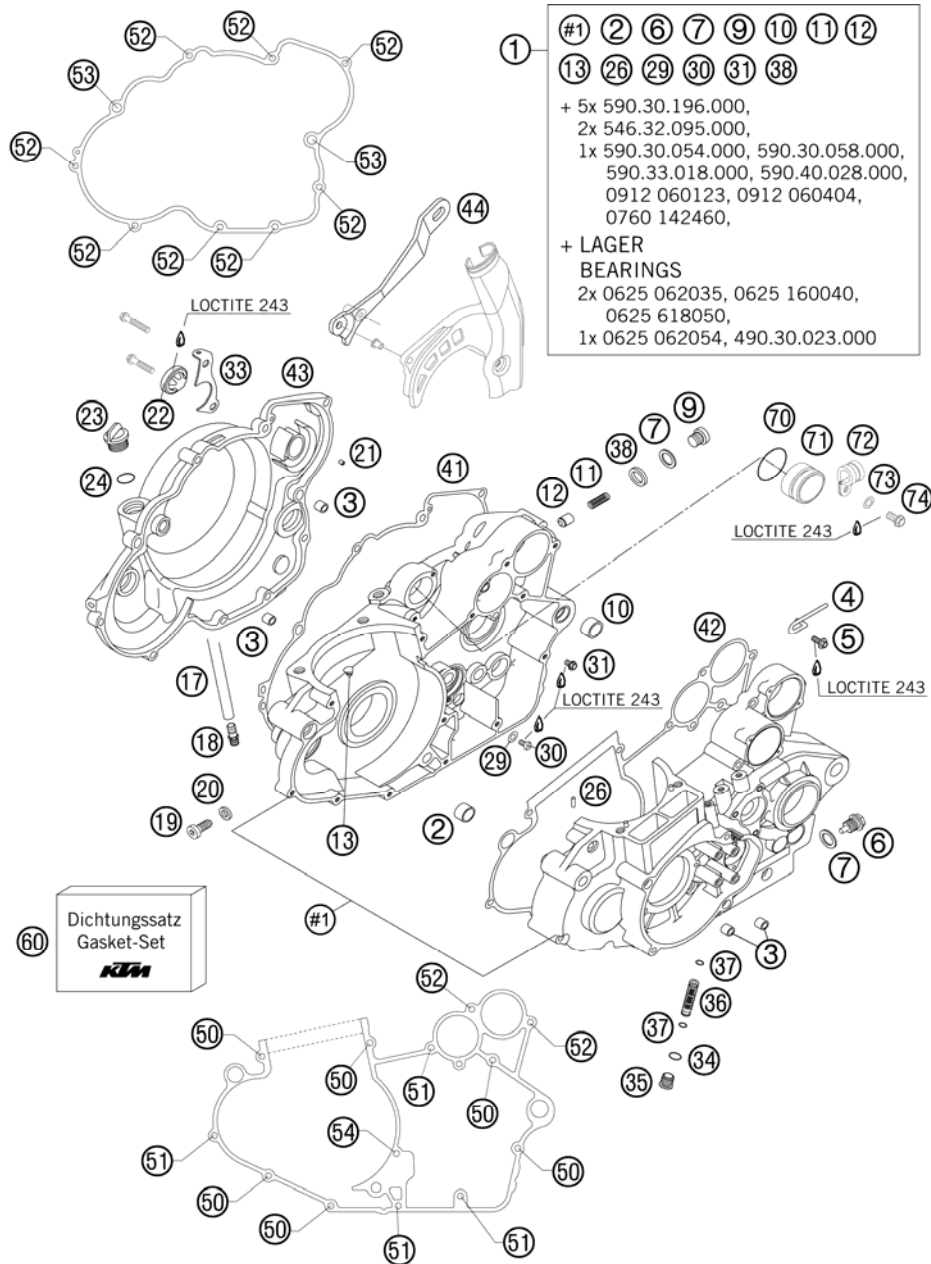

FIG	PART NUMBER	DESCRIPTION	QTY
1*	59030000444	ENGINE CASE 2006	1
2	51030026100	DOWEL 17 X 13 X 12	1
3	49030090000	DOWEL 9,8 X 7 X 10	4
4	59030090000	HANGER FOR VENT HOSE	1
5	0014060153	HH COLLAR SCREW M 6X15 WS=8	1
6	58030021000	OILDRAIN PLUG W.MAG. M 12X1,5	1
7	58038022000	CU-SEAL RING DIN7603-12X18X1,5	2
9	0908120153	PLUG DIN0908-M12X1,5	1
10	59030024000	DOWEL 17 X 19 X 12	1
11	58038023300	PRESSURE SPRING L=25MM D=1MM	1
12	58038028000	VALVE PISTON D=10MM	1
13*	59030054000	JET 60 DELLORTO M6X0,75	1
17	59031050100	ENGINE BREATHER TUBE 00	1
18	59030022100	BLEEDER FLANGE M12X1,5 WS=13	1
19	59430080000	LOCATING SCREW L=27	1
20	58030081000	CU-SEAL RING 8 X 14 X 3	1
21	0402025980	NEEDLE ROLLER DIN5402 2,5X9,8	1
22	59030019000	OIL LEVEL GLASS G 1777 Y	1
23	58030020000	PLUG M 24X3	1
24	0770191015	O-RING 19,00X3,00 NBR	1
26	0402040980	NEEDLE ROL.DIN5402 NRB 4X9,8	2
29	0125050003	WASHER DIN0125-A 5,3	1
30	0985050083	FLAT HEAD SCREW DIN7985-M 5X 8	1
31	0015060083	HH COLLAR SCREW M 6X8 WS=8	1
33	59030001090	RET.BRACKET F.BRAKE LEVER HUB	1
34	0770120020	O-RING 12,00X2,00 NBR 70	1
35	59038014000	PLUG M16X1,5	1
36	59038015000	OIL SCREEN 11,8X44,5MM	1
37	0770090015	O-RING 9X1,5 NBR	2
38	0603121830	SEAL RING DIN7603 12X18X3	1
41	59030025100	GASKET FOR CLUTCH COVER	1
42	59030039100	ENGINE CASE GASKET NS92-24	1
43	59030001000	CLUTCH COVER RACING 2000	1
44*	59030047100	CHAIN DAMPING PLATE RAC. 2005	1
50	0015060453	HH COLLAR SCREW M 6X45 WS=8	6
51	0015060603	HH COLLAR SCREW M 6X60 WS=8	4

065903001 / C065903006

* NEW PART

X AS REQUIRED

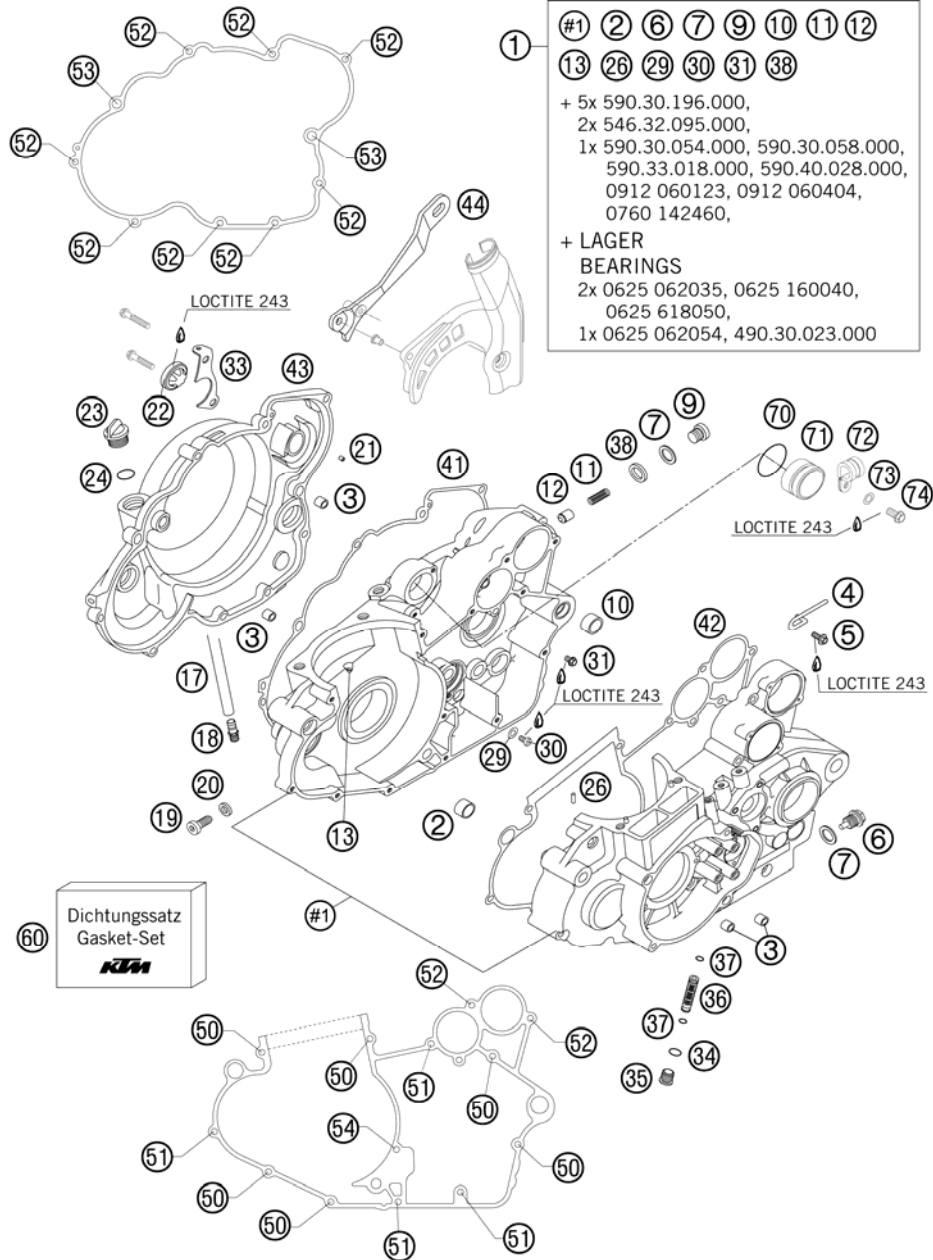

FIG	PART NUMBER	DESCRIPTION	QTY
52	0015060303	HH COLLAR SCREW M 6X30 WS=8	10
53	0015060353	HH COLLAR SCREW M 6X35 WS=8	2
54	0015060753	HH COLLAR SCREW M 6X75 WS=8	1
60	59030099000	GASKET SET CPL. RACING 2000	1
70*	0770250030	O-RING 25,00X3,00 NBR 70	1
71*	59040034000	CAP COVER	1
72*	59007439000	CLAMP RSGU 18/15 03	1
73*	0125060003	WASHER DIN0125-A 6,4	1
74*	0015060123	HH COLLAR SCREW M 6X12 WS=8	1

065903001 / C065903006

* NEW PART

X AS REQUIRED

CRANKSHAFT, PISTON

450 SX 2006

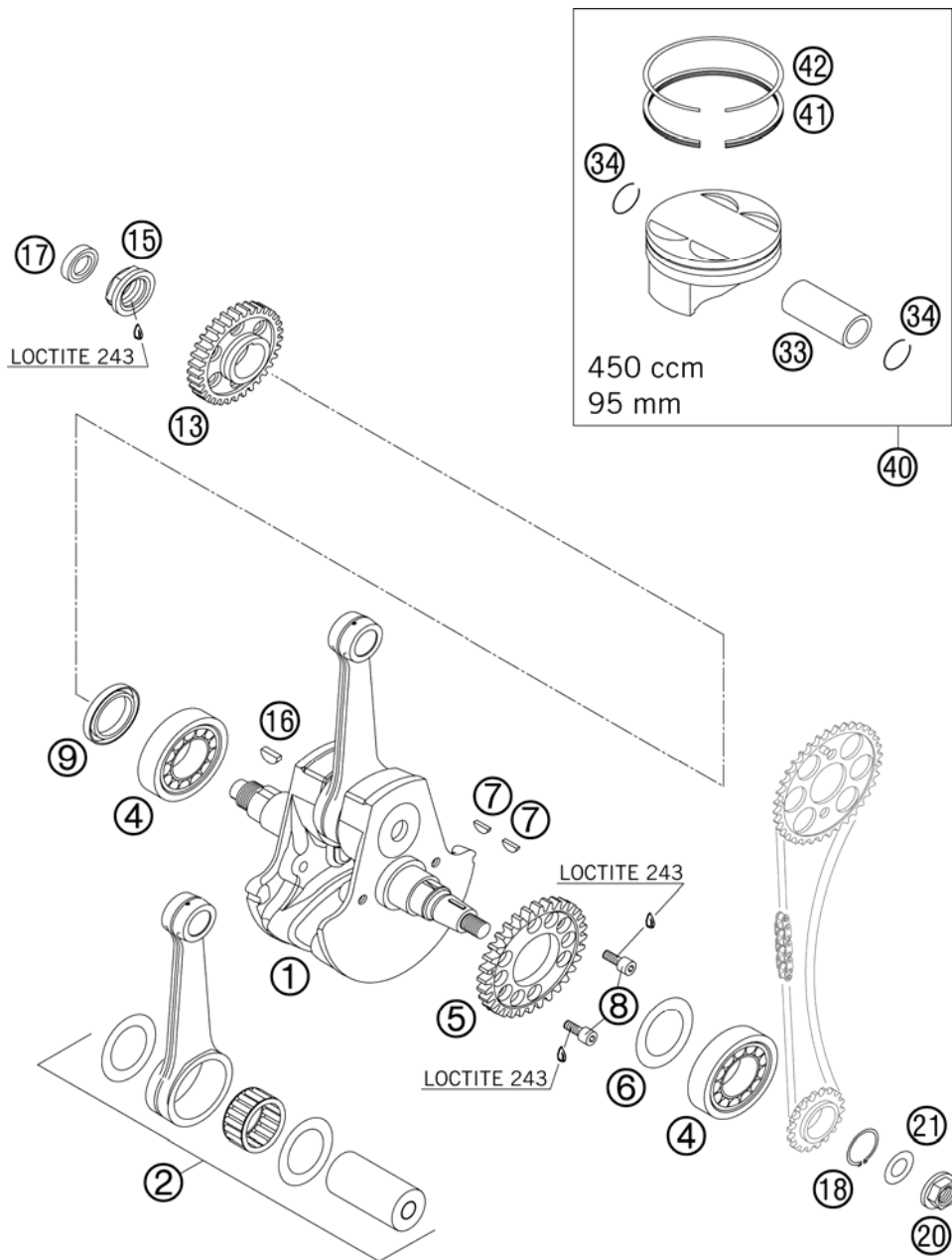

FIG	PART NUMBER	DESCRIPTION	QTY
1*	59430018100	CRANKSHAFT 06 STROKE 72MM, WITHOUT WASHER	1
2*	59430015044	CON.ROD REP.SET 450 RAC. 03 WITH WASHER	1
4*	80030019000	CYL.ROLLBEAR.NJ206ECP/C3HVC058	2
5	59030055000	DRIVE GEAR 32-T F.BALANC.SHAFT	1
6	56030081000	THRUST WASHER 30,5X45X0,10	x
6	56030081100	THRUST WASHER 30,7X47X0,15	x
6	56030081200	THRUST WASHER 30,5X45X0,30	x
7	0888030050	WOODRUFF KEY DIN6888-3X5X13	2
8	0984060162	AH SCREW DIN7984-M 6X16	2
9	0760304772	SH.SEAL RING 30X47X7 BSL VITON	1
13	59032000033	PRIMARY GEAR 33-T	1
15	59030029100	HH NUR M20X1,5 WS=27 LEFT	1
16	6946005	WOODRUFF KEY 5X6,5 HARDED	1
17	0760142460	SHAFT SEAL RING 14X24X6 B	1
18	0471250120	CIRCLIP DIN0471-25X1,2	1
20	49030021000	COLLAR NUT M12X1 R/S	1
21	0137120000	SPRING WASHER DIN0137-B12	1
33	59430033000	PISTON PIN BOLT 20X12X45,5	1
34	59430174000	CIRCLIP 20X1,6	2
40	59430107100 I	PISTON CPL. 450 D=95MM SI.1 05	1
40	59430107100 II	PISTON CPL. 450 D=95MM SI.2 05	1
41	59430031000	OIL SCRAPER RING 95/88,5X2,5	1
42	59030032000	RECTANGULAR RING 95/87,2X1,25	1

065903003 / C065903010

* NEW PART

X AS REQUIRED

BALANCER SHAFT

450 SX 2006

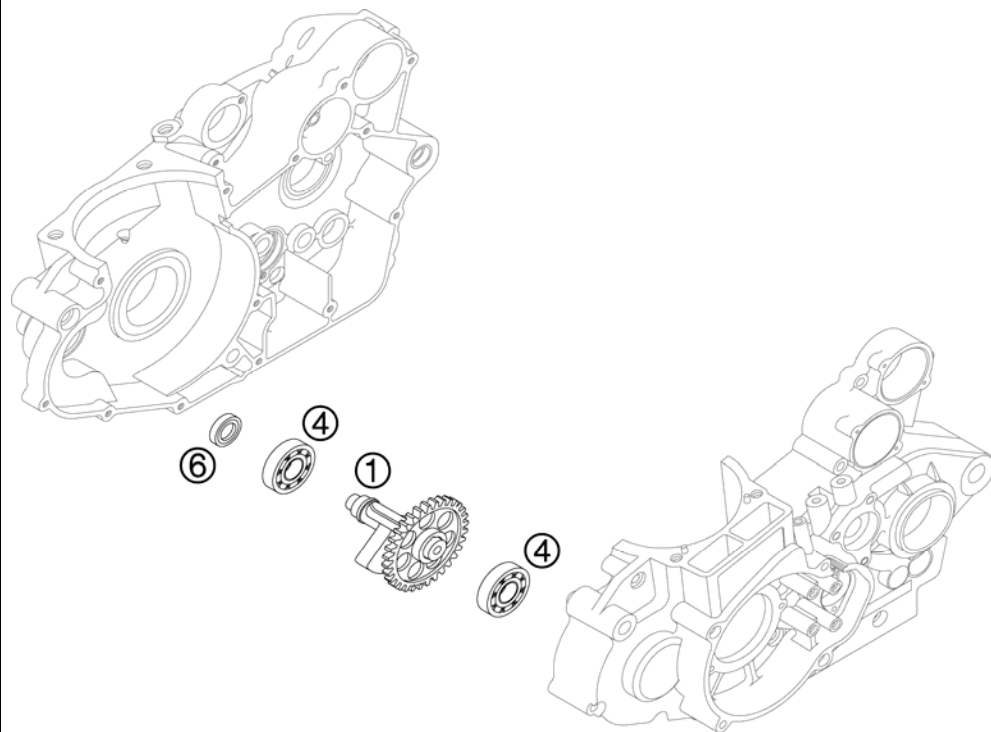

FIG	PART NUMBER	DESCRIPTION	QTY
1	59830057044	BALANCER SHAFT W. GEARWHEEL 02	1
4	0625160040	GROOVED BALL BEAR. TM 16004 C3	2
6	0760142460	SHAFT SEAL RING 14X24X6 B	1

065903009 / C065903013

* NEW PART

X AS REQUIRED

CYLINDER

450 SX 2006

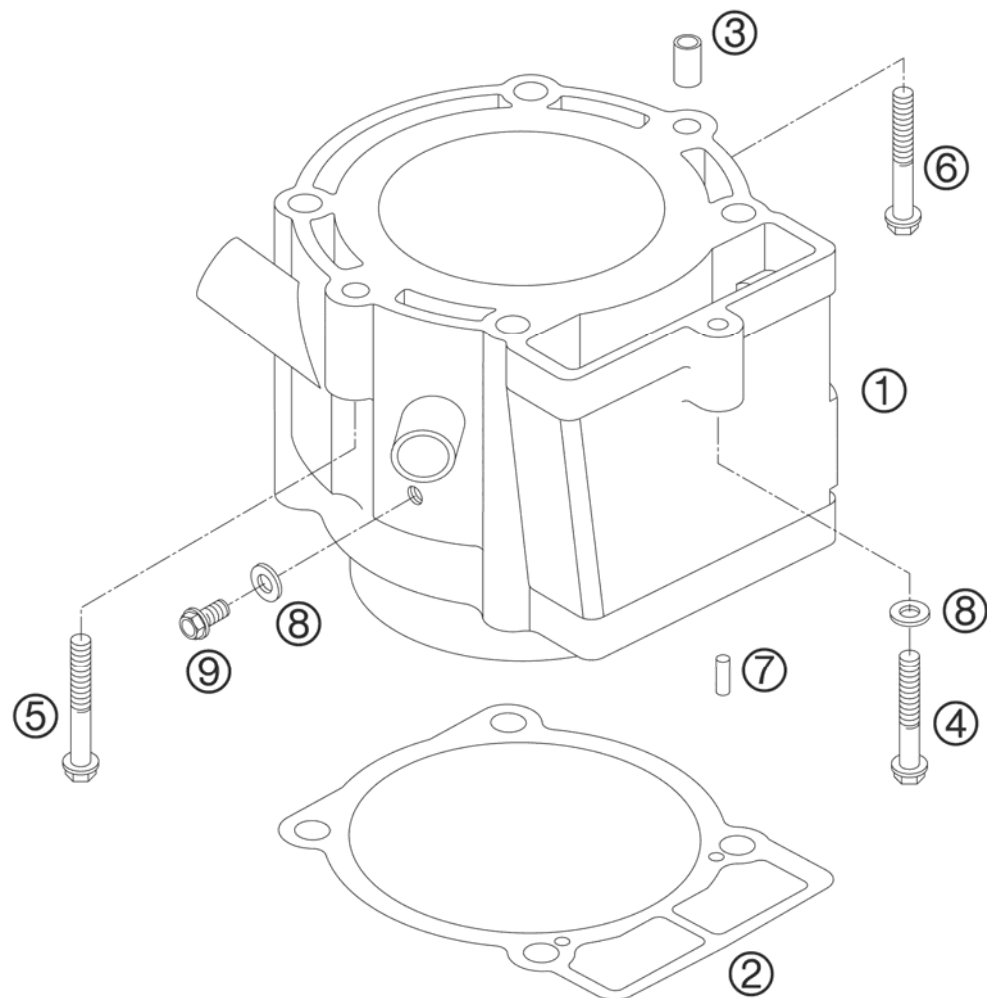

FIG	PART NUMBER	DESCRIPTION	QTY
1	59430005000	CYLINDER 450 SX D=95/L=68 03	1
2	59030035050	CYLINDER BASE GASKET 0,5MM	1
3	59030023000	DOWEL 6X8X11,5	2
4	0015060303	HH COLLAR SCREW M 6X30 WS=8	1
5	0015060403	HH COLLAR SCREW M 6X40 WS=8	1
6	0015060353	HH COLLAR SCREW M 6X35 WS=8	1
7	0402040980	NEEDLE ROL.DIN5402 NRB 4X9,8	2
8	0603061001	CU-SEAL RING DIN7603-6X10X1	2
9	0015060103	HH COLLAR SCREW M 6X10 WS=8	1

05590307 / C065903015

* NEW PART

X AS REQUIRED

CARBURETOR

450 SX 2006

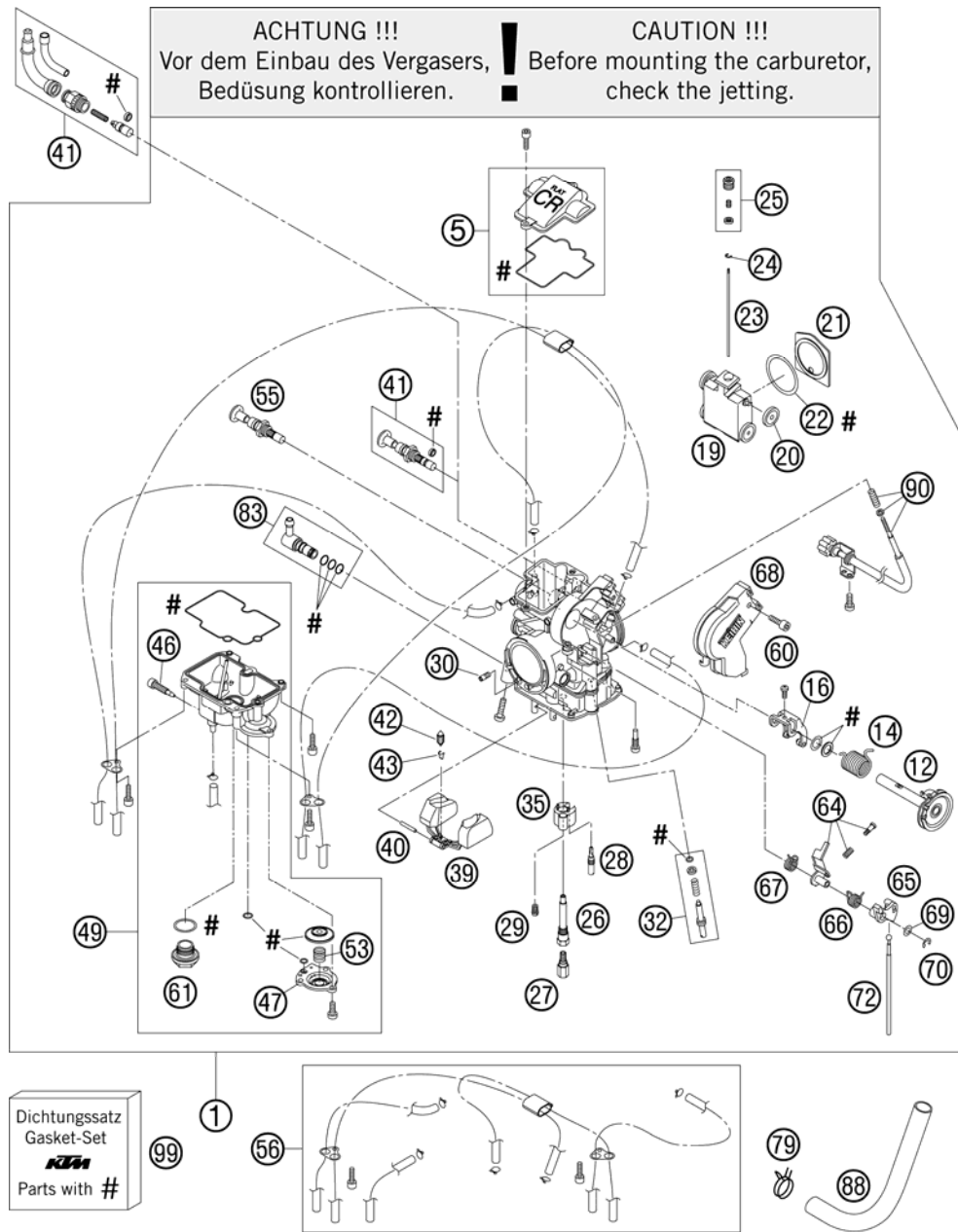

FIG	PART NUMBER	DESCRIPTION	QTY
1*	59431001400	CARBURETOR FCR-MX 4122B 06	1
5*	57331027044	CARBURETOR COVER WITH GASKET	1
12*	57331046200	THROTTLE SHAFT CPL. 06	1
14	57331046050	COIL SPRING THROTTLE SHAFT	1
16	57331035051	LINK ARM THROTTLE VALVE CPL.	1
19	57331035000	THROTTLE VALVE CPL.	1
20	59031035050	BUSHING THROTTLE VALVE	4
21	57331035153	GASKET PLATE THROTTLE VALVE 04	1
22	59031035052	GASKET WASHER THROTTLE VALVE	1
23	59031021000	JET NEEDLE KEIHIN OBDTM	x
23	59031022000	JET NEEDLE KEIHIN OBDVR	x
23	59031023200	JET NEEDLE KEIHIN OBDVT	x
23	59031034000	JET NEEDLE KEIHIN OBDTN	x
23	59031034400	JET NEEDLE KEIHIN OBDTP	x
23	59031034500	JET NEEDLE KEIHIN OBDTQ	x
23	59031034600	JET NEEDLE KEIHIN OBDTR	x
24	59031029000	BAR CLIP	1
25	57331032000	NEEDLE SET SCREW CPL.	1
26	59031121000	NEEDLE JET FCR-MX	1
27	54531623180	MAIN JET 180 KEIHIN	x
27	54531623182	MAIN JET 182 KEIHIN	x
27	54531623185	MAIN JET 185 KEIHIN	x
27	54531623188	MAIN JET 188 KEIHIN	x
27	54531623190	MAIN JET 190 KEIHIN	x
27	54531623195	MAIN JET 195 KEIHIN	x
28	54531607038	IDLE JET 38 KEIHIN	x
28	54531607040	IDLE JET 40 KEIHIN	x
28	54531607042	IDLE JET 42 KEIHIN	1
28	54531607045	IDLE JET 45 KEIHIN	x
29	59031051085	STARTER JET 85	1
30*	57331107100	IDLE AIR JET 100 KEIHIN	1
32	59031017100	ADJUST SCREW CPL. FCR-MX	1
35	57331085000	BUFFER PLATE	1
39	57331009000	FLOAT CPL.	1
40	57331008000	ARM PIN FLOAT	1
41*	57331075100	HOT-STARTER VALVE CPL. 06 SX, SMR	1

065903103 / C065903103

* NEW PART

X AS REQUIRED

CARBURETOR

450 SX 2006

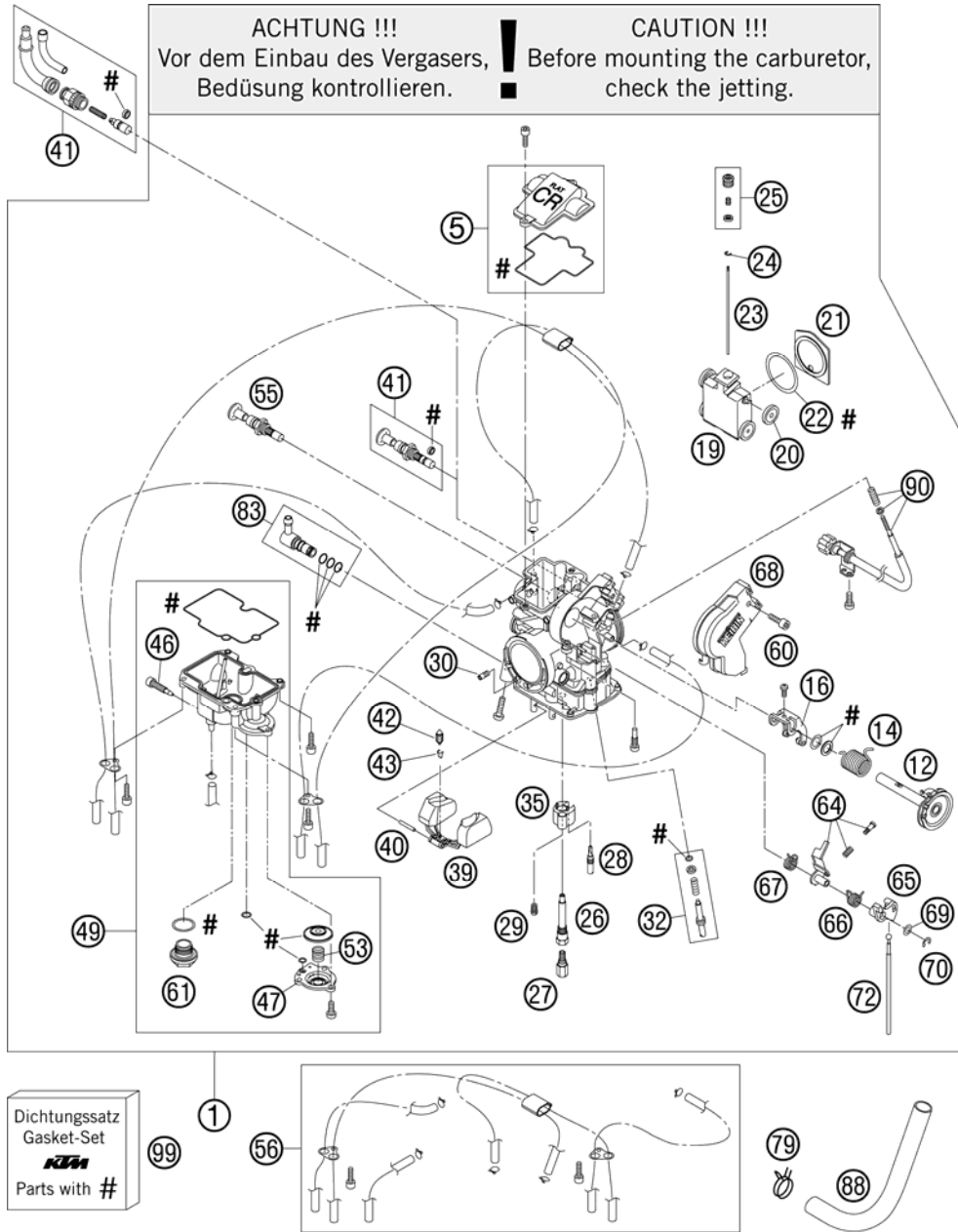

FIG	PART NUMBER	DESCRIPTION	QTY
41*	77031075000	HOT-STARTER VALVE	1
42*	54631220000	FLOAT NEEDLE	1
43*	54531621000	CLAMP	1
46	57331155000	DRAIN SCREW FLOAT CHAMBER	1
47	57331060000	COVER ACCELERATOR PUMP	1
49	57331011000	FLOAT CHAMBER CPL. SET	1
53	59031059000	COIL SPRING	1
55	57331048000	STARTER VALVE CPL.	1
56	57331098000	BREATH.HOSE FCR-MX KEIHIN CPL.	1
60	57331038100	SCREW F. COVER KEIHIN	1
61	54531699000	PLUG M 18X1	1
64	57331062000	INTERMEDIATE LEVER CPL.	1
65	57331056000	LINK LEVER	1
66	57331059000	SPRING LINK LEVER	1
67	57331159000	SPRING INTERMEDIATE LEVER	1
68*	57331038200	CARBURETOR COVER 06	1
69	57331087000	WASHER LINK LEVER	1
70	57331084000	E-CLIP	1
72	57331061000	ROD ACCELERATOR PUMP	1
79	58431082100	YDNAC-CLAMP 10173 (16MM) '98	1
83	59031013044	HOSE CONNECTOR CPL.	1
88	59031050100	ENGINE BREATHER TUBE 00	1
90	57331025000	STOP SCREW CPL. FCR-MX	1
99	57331099000	GASKET SET FCR-MX KEIHIN	1

065903103 / C065903103

* NEW PART

X AS REQUIRED

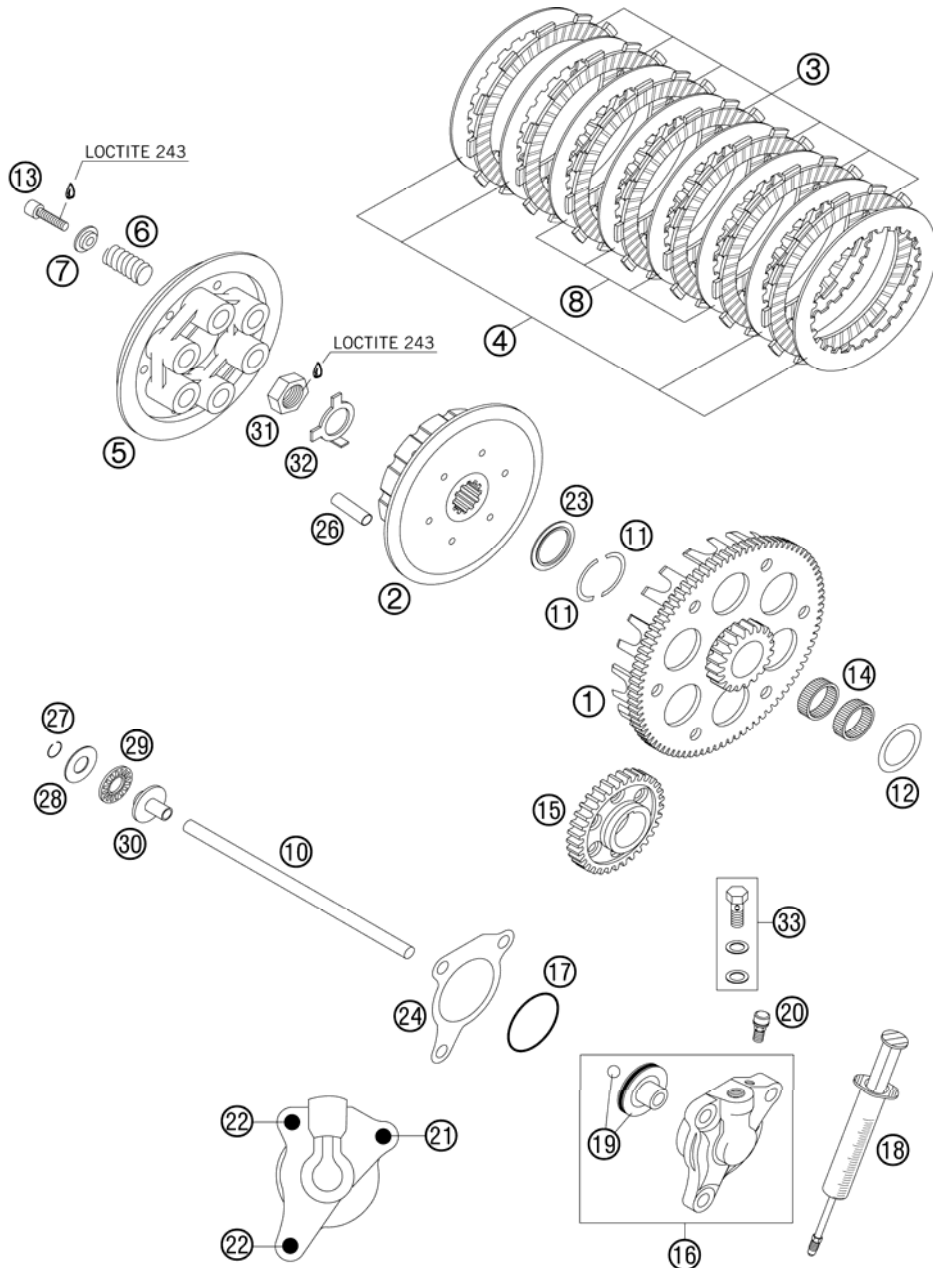

FIG	PART NUMBER	DESCRIPTION	QTY
1*	59032000476	OUTER CLUTCH HUB 76-Z/20-Z 01 HARDED	1
2*	59032002250	INNER HUB 06	1
3	59032011100	LINING DISC 2MM 04	7
4	59032010100	INTERMEDIATE DISC 1MM 2002	4
5*	59032003350	PRESSURE CAP WITH OIL BORE 06	1
6	59032005000	CLUTCH SPRING 2,5X43MM	6
7*	59032006050	SPRING RETAINER 6,2X12X18X5,2	6
8*	59032010200	INTERMEDIATE DISC 1,4MM 2002	4
10*	59032054200	PUSH ROD 7x189,6 MM 06	1
11	59032007000	HALF-WASHER 03	2
12	59032017000	SUPPORTWASHER 25X35X1	1
13	0984060252	AH SCREW DIN6912 M6X25	6
14	0405252910	NEEDLE BEAR K 25X29X10	2
15	59032000033	PRIMARY GEAR 33-T	1
16	59032061044	OUTPUT CYLINDER CPL. 2003	1
17	0770300015	O-RING 30,00X1,50 NBR 70	1
18	50329050000	VENT INJEKTION HYDR. CLUTCH	1
19	59032066000	PISTON WITH O-RING AND BALL 03	1
20	54732064000	BLEEDER SCREW WITH CAP	1
21	0015060353	HH COLLAR SCREW M 6X35 WS=8	1
22	0015060203	HH COLLAR SCREW M 6X20 WS=8	2
23	59032009000	STEPPED WASHER 03	1
24	59032065000	GASKET FOR SLAVE CYLINDER	1
26*	59032004300	DRIVING SLEEVE D=8, L=33 06	12
27	0993012000	CIRCLIP DIN7993-RW12	1
28	54637098200	AXIAL WASHER AS1226 12X26X1	1
29	54637097200	AXIAL NEEDLE BEARING AXK 1226	1
30	50332054051	PRESSURE PIECE 125-380 '98	1
31	0936181505	HEXAGON NUT DIN0936-M18X1,5 R.	1
32	56532018000	LOCK WASHER	1
33	59032062000	HOLLOW SCREW HYDR. CLUTCH CPL.	1

065903200 / C065903200

* NEW PART

X AS REQUIRED

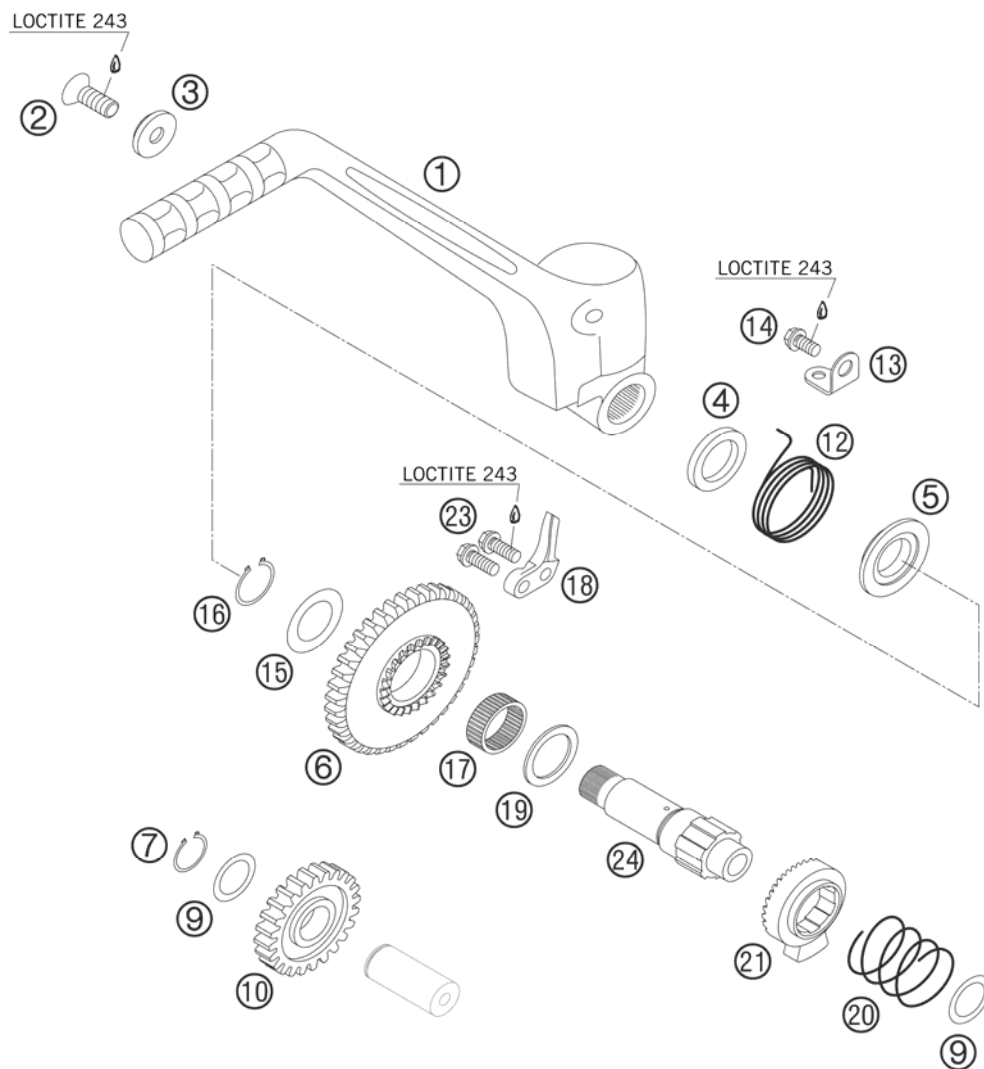

FIG	PART NUMBER	DESCRIPTION	QTY
1	54833070044	KICKSTARTER CPL. '03	1
2	54610052000	SPROCKET SCREW-AH M8X20 WS=6	1
3	54633037000	WASHER 8MM GALVANIZED	1
4	0760193070	SHAFT SEAL RING 19X30X7 B	1
5	59033055000	DRIVING HUB	1
6	59033051039	KICKSTARTER GEAR 39-T	1
7	0471170010	CIRCLIP DIN0471-17X1	1
9	0988172405	SHIM WASHER DIN0988-17X24X0,5	2
10	59033053000	INTERMEDIATE GEAR 24-T	1
12	59033054000	KICKSTARTER SPRING	1
13	59033074000	SPRING HANGER	1
14	0015060123	HH COLLAR SCREW M 6X12 WS=8	1
15	59033080000	SHIM 20X32X1	1
16	0471190120	CIRCLIP DIN0471-19X1,2	1
17	0405222610	NEEDLE BEARING K 22X26X10 A	1
18	59033069000	BUMP PART	1
19	58033031000	STOP DISK 22,2 X 30 X 1,5	1
20	58033028000	RATCHET GEAR SPRING 1,2 MM	1
21	59033052000	RATCHET GEAR KICKSTARTER	1
23	0015060203	HH COLLAR SCREW M 6X20 WS=8	2
24	59033050000	KICKSTARTER SHAFT RACING 2000	1

05590330 / C065903300

* NEW PART

X AS REQUIRED

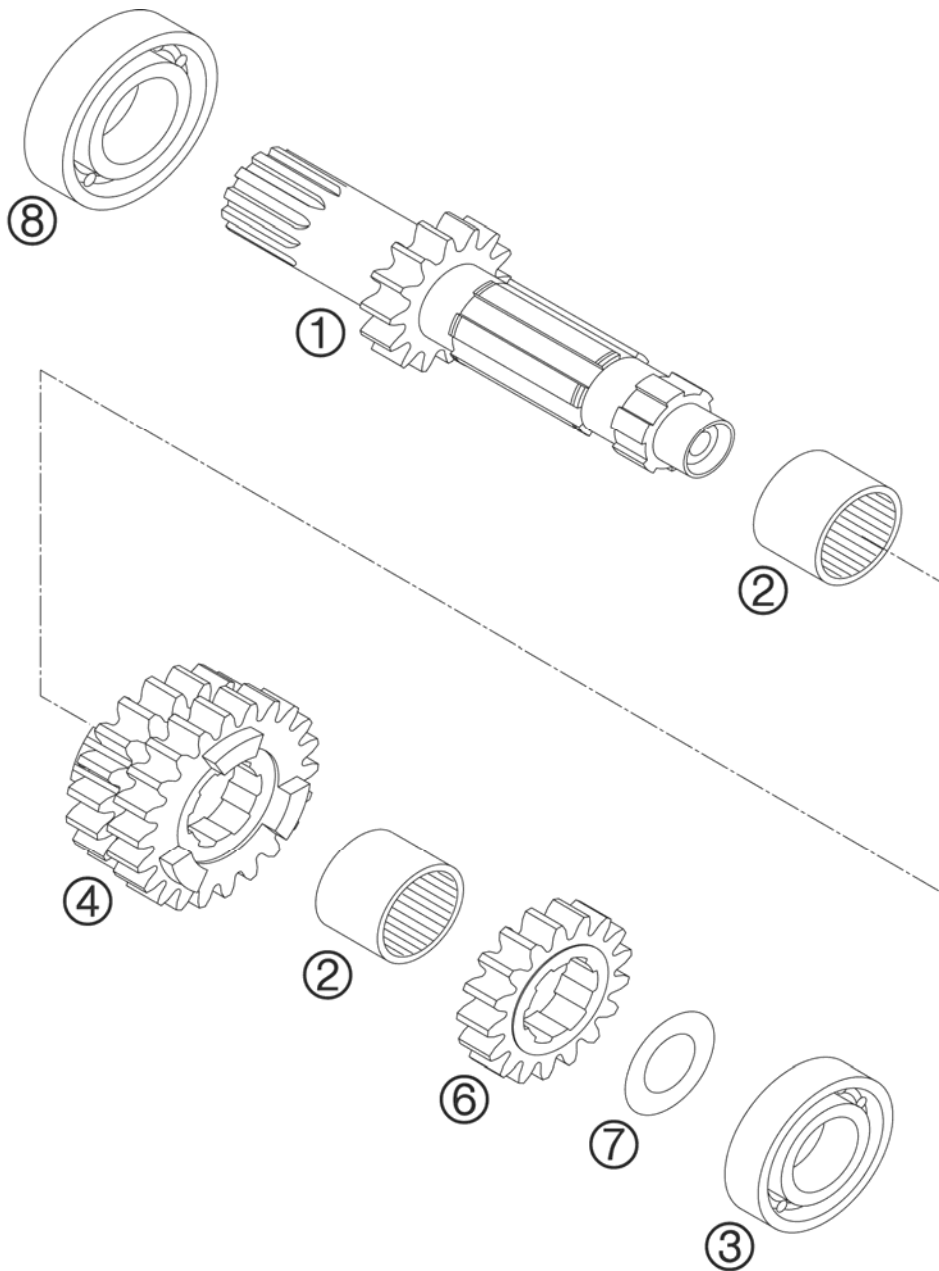

FIG	PART NUMBER	DESCRIPTION	QTY
1	59033001300	MAIN SHAFT-ZB 16-T SX 03	1
2	59033032100	SPACER BUSHING 25X30X24,4	2
3	0625062035	BALL BEARING 6203 JR2 C3	1
4	59033003046	SLIDING GEAR 3/4.G 20/22-T"46"	1
6	59033002037	SOLID GEAR 2.G 18-T "37"	1
7	56033030000	STOP DISC 17,2X30X1	1
8	0625062054	BALL BEARING 6205 C3 NTN	1

05590332 / C065903304

* NEW PART

X AS REQUIRED

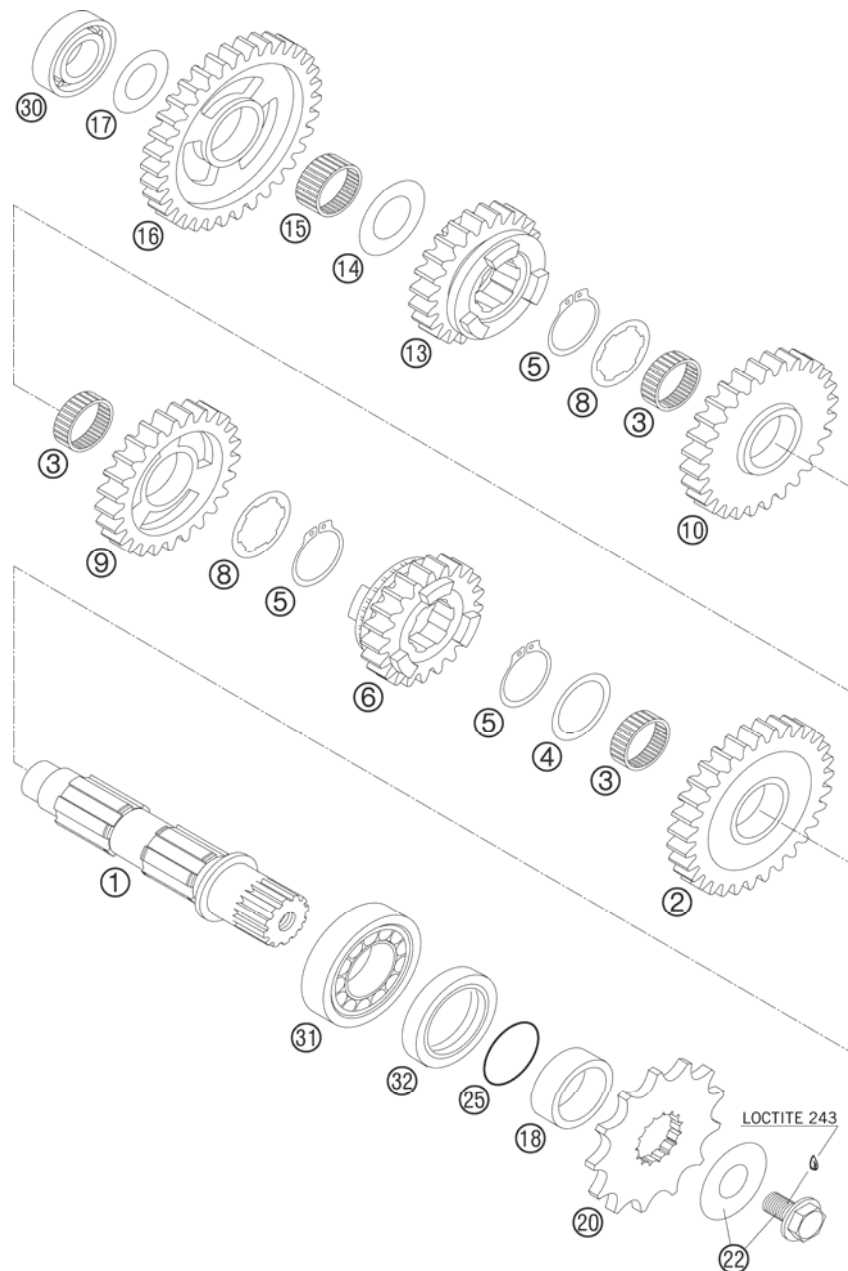

FIG	PART NUMBER	DESCRIPTION	QTY
1	59033010000	COUNTER SHAFT RACING 2000	1
2	59033012036	IDLER GEAR 2.G 30-T "36"	1
3	0405222611	NEEDLE BEAR.K 22X26X10 DIVIDED	3
4	59033031000	STOP DISC 25,2X32X1,5	1
5	0471250120	CIRCLIP DIN0471-25X1,2	3
6	59033016026	SLIDING GEAR 6.G 21-T "26"	1
8	59033030000	STOP DISC 25,2X32X1,5	2
9	59033014033	IDLER GEAR 4.G 26-T "33"	1
10	59033013047	IDLER GEAR 3.G 28-T "47"	1
13	59033015029	SLIDING GEAR 5.G 23-T "29"	1
14	59033080000	SHIM 20X32X1	1
15	0405202612	NEEDLE BEARING K 20X26X12	1
16	59033011043	IDLER GEAR 1.G 32-T "43"	1
17	56033030000	STOP DISC 17,2X30X1	1
18	54633014100	SPACER BUSHING 12MM	1
20	50033029013	SPROCKET 13-T	x
20	50033029014	SPROCKET 14-T	x
20	50033029015	SPROCKET 15-T	x
22	59033034044	SCREW+SPRING WASHER	1
25	0770020220	O-RING 25,12X1,78 NBR70	1
30	0625062035	BALL BEARING 6203 JR2 C3	1
31	49030023000	CYL.ROLL BEARING NJ205	1
32	0760324571	SHAFT SEAL RING 32X45X7 BSLNBR	1

05590336 / C065903308

* NEW PART

X AS REQUIRED

SHIFTING MECHANISM

450 SX 2006

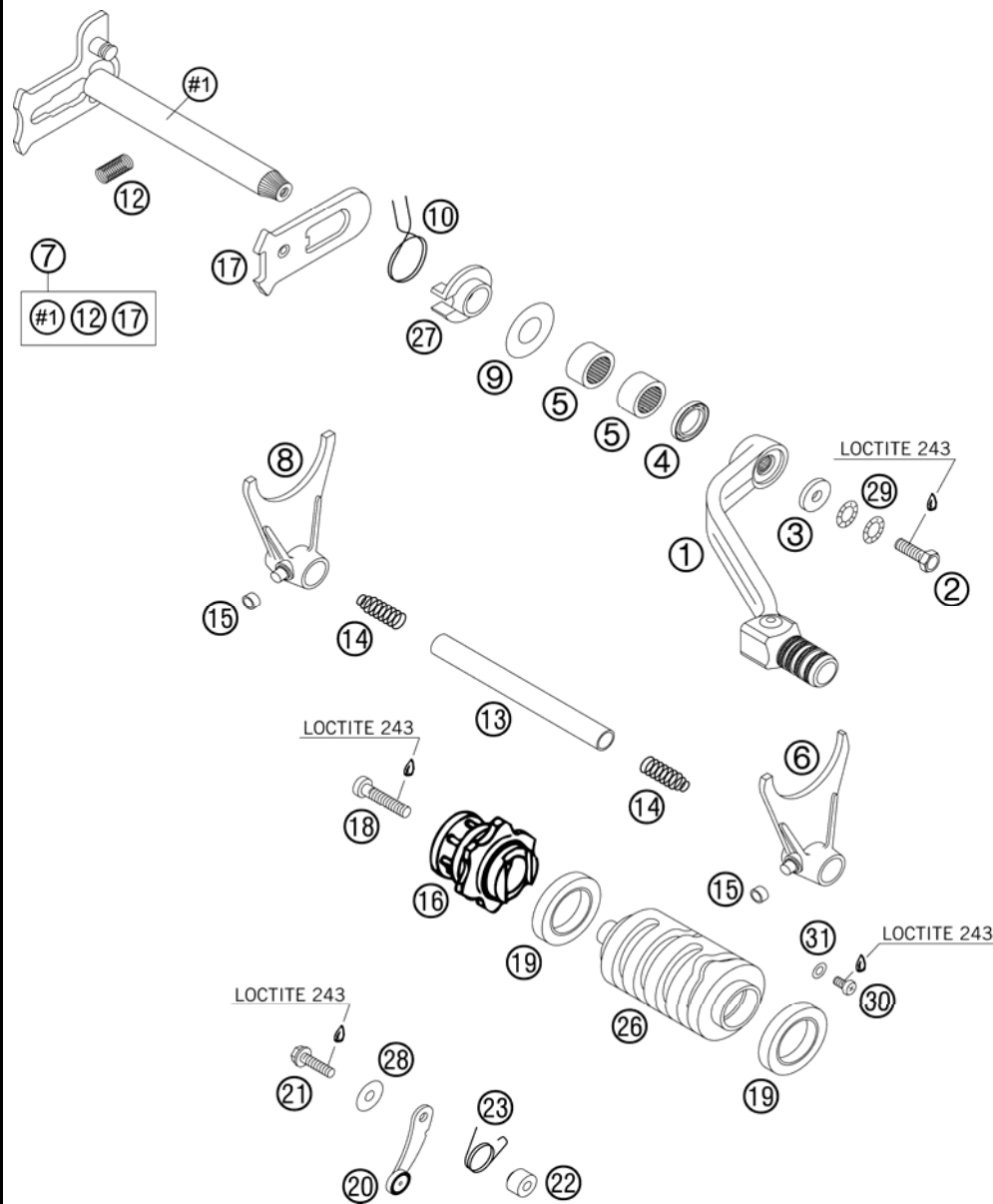

FIG	PART NUMBER	DESCRIPTION	QTY
1	59034031000	SHIFTING LEVER CPL.RACING 2000	1
2	0933060165	HH SCREW DIN0933-M 6X16 10.9	1
3	50232050001	STEEL WASHER 6,4X17X3	1
4	0760142460	SHAFT SEAL RING 14X24X6 B	1
5	54632095000	NEEDLE BEAR.HK 1412 14X20X12	2
6	59034002000	SHIFT FORK 2./4.GEAR 2000	1
7	59034005044	SHIFT SHAFT CPL. RACING '03	1
8	59034003000	SHIFT FORK 1./3.GEAR 2000	1
9	54634050000	STOP DISK 14X30X1	1
10	54634014100	RETURN SPRING 2,2MM '95	1
12	56534013100	TENSIONING SPRING 0,8MM	1
13	59034020000	SHIFT RAIL 11,8X105MM	1
14	58038023200	PRESSURE SPRING 0,9MM	4
15	50334018100	SHIFTING ROLLER 6X8X5,2	3
16	59034015044	SHIFT LOCATING DRUM ALU CPL.00	1
17	54634008044	SLIDING PLATE CPL.	1
18	0984060302	AH SCREW DIN6912 M 6X30	1
19	0625618050	BALL BEARING 61805 C3	2
20	54634024144	LOCKING LEVER CPL '96	1
21	0015050203	HH COLLAR SCREW M 5X20 WS=8	1
22	54634052300	SLEEVE FOR LOCKING LEVER	1
23	59034023000	SPRING 2,3MM	1
24	59034019000	SHIFT RAIL 11,8X89MM	1
25	59034001000	SHIFT FORK 5./6.GEAR 2000	1
26*	59434012000	SHIFTROLLER 4-GEAR	1
27	54634020000	SPRING GUIDE	1
28	0349000050	WASHER DIN7349-5X15X2	1
29	50233041000	PAIR OF WASHERS M 6 NORDLOCK	2
30	0985050083	FLAT HEAD SCREW DIN7985-M 5X 8	1
31	0125050003	WASHER DIN0125-A 5,3	1

065903401 / C065903401

* NEW PART

X AS REQUIRED

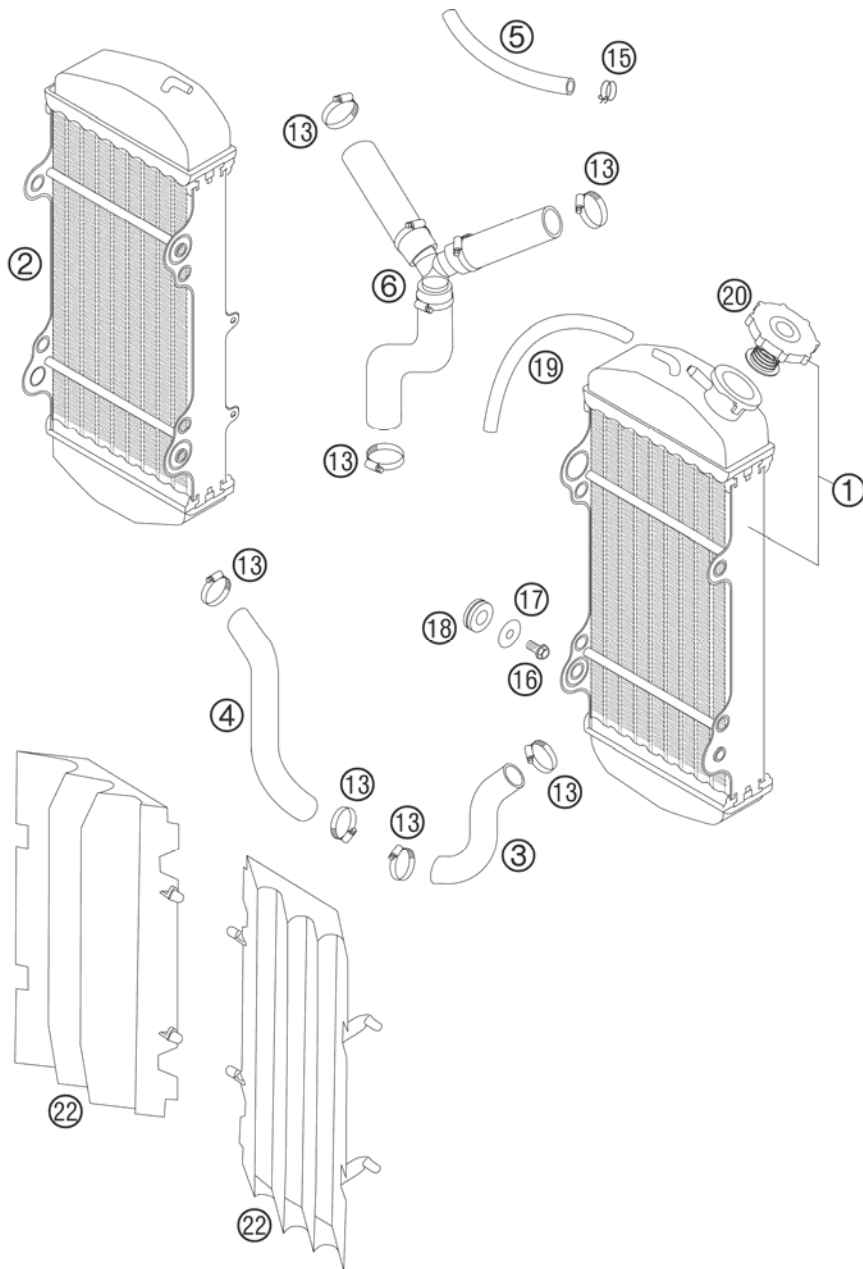

FIG	PART NUMBER	DESCRIPTION	QTY
1	59035007300	RADIATOR L/S 45.407 03	1
2	59035008300	RADIATOR R/S 45.408 03	1
3	59035024100	RADIATOR HOSE L/S RAD.-CYL. 03	1
4	59035124100	RADIATOR HOSE R/S RAD.-CYL. 03	1
5	54435024001	HOSE ID 7,5 PER METER	1
6	59035125000	RADIATOR HOSE CYL.HEAD-RAD. 03	1
13	10001020000	HOSE CLAMP GEMI 16-27	7
15	50231005000	HOSE CLAMP YDNAC 10119 11MM	2
16	0015060123	HH COLLAR SCREW M 6X12 WS=8	4
17	0021060003	WASHER DIN9021-A 6,4	4
18	41001052000	RUBBER SLEEVE D=12MM	4
19	55007016001	PVC-HOSE 7X10 PER METER	1
20	59035009000	RADIAT.CAP 20,3PSI (1,4BAR) 03	1
22	5903504000004	RADIAT. PROTECT.RAC. ORANGE 03	x
22	5903504000030	RADIAT. PROTECT. RAC. BLACK 06	2

05590350 / C065903501

* NEW PART

X AS REQUIRED

CYLINDER HEAD

450 SX 2006

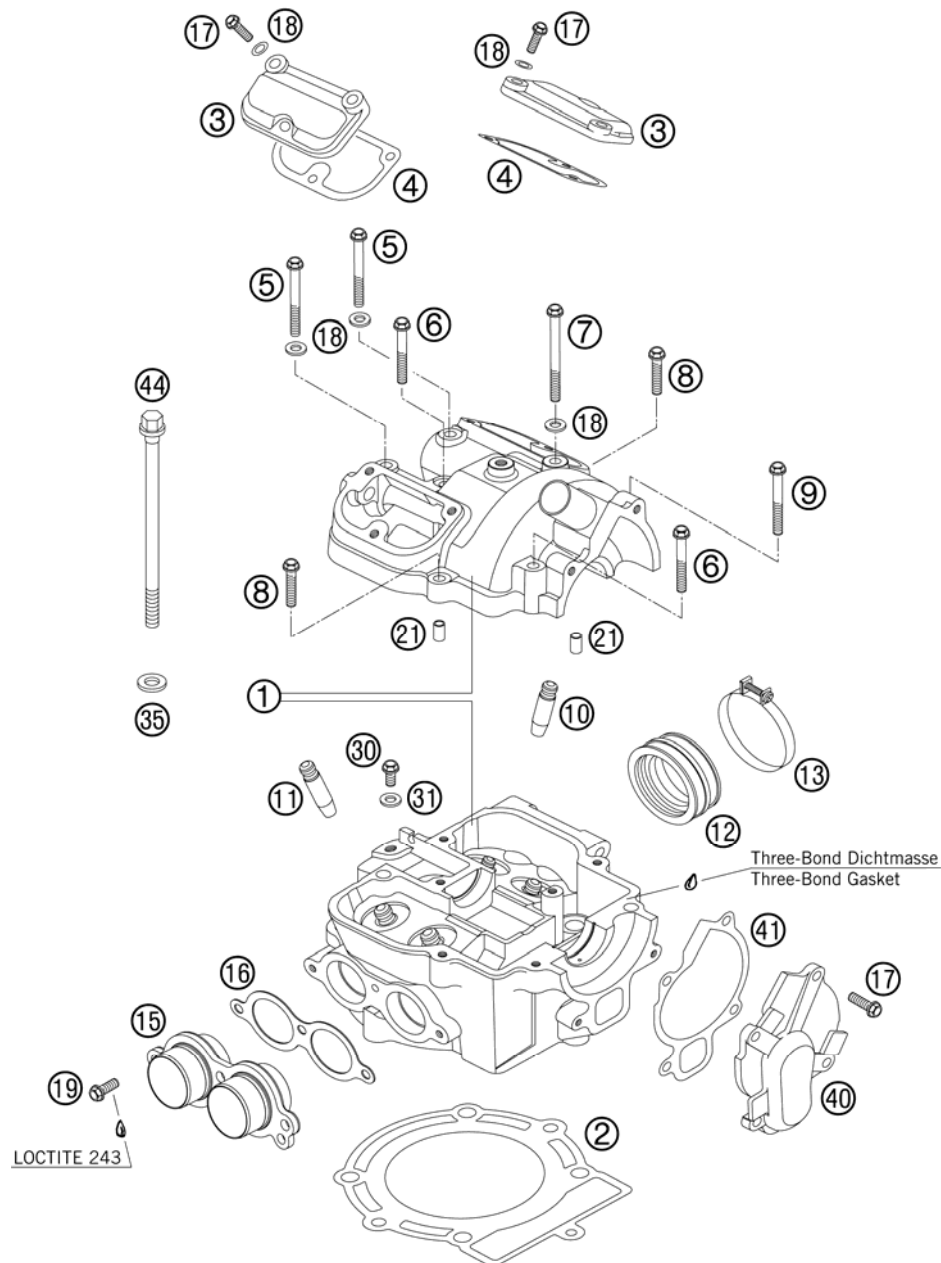

FIG	PART NUMBER	DESCRIPTION	QTY
1	59436020144	CYL.HEAD CPL.450/525 SX+SMR	1
2	59030036000	CYLINDER HEAD GASKET 95,3 MM	1
3*	58036052200	VALVE COVER REAR	2
4	58036053000	VALVE COVER GASKET	2
5	0015060556	HH COLLAR SCR. M6X55 WS=8 10.9	2
6	0015060453	HH COLLAR SCREW M 6X45 WS=8	2
7	0015060753	HH COLLAR SCREW M 6X75 WS=8	1
8	0015060303	HH COLLAR SCREW M 6X30 WS=8	2
9	0015060503	HH COLLAR SCREW M 6X50 WS=8	1
10*	59036025101	VALVE GUIDE INTAKE	2
11*	59036026101	VALVE GUIDE EXHAUST	2
12*	59436044100	INTAKE BOOT	1
13	59030061000	CLAMP D=56MM B=9MM M4X25	2
15	59436039000	EXHAUST FLANGE CPL. 450/525 03	1
16	59036041000	GASKET EXHAUST FLANGE	1
17	0015060203	HH COLLAR SCREW M 6X20 WS=8	10
18	0603061001	CU-SEAL RING DIN7603-6X10X1	7
19	0015060163	HH COLLAR SCREW M 6X16 WS=8	3
21	59030023000	DOWEL 6X8X11,5	2
30	59036006090	VENT SCREW M6X10 CPL.	1
31	58036065100	CU-SEAL RING 6 X 10 X 2	1
35	59036090000	WASHER 10,8X18,8X1,5	4
40	59035052000	WATER PUMP COVER RACING 2000	1
41	59035053000	WATER PUMP COVER GASKET 0,8MM	1
44	59436079000	CYLINDER HEAD SCREW M10X142	4

065903601 / C065903604

* NEW PART

X AS REQUIRED

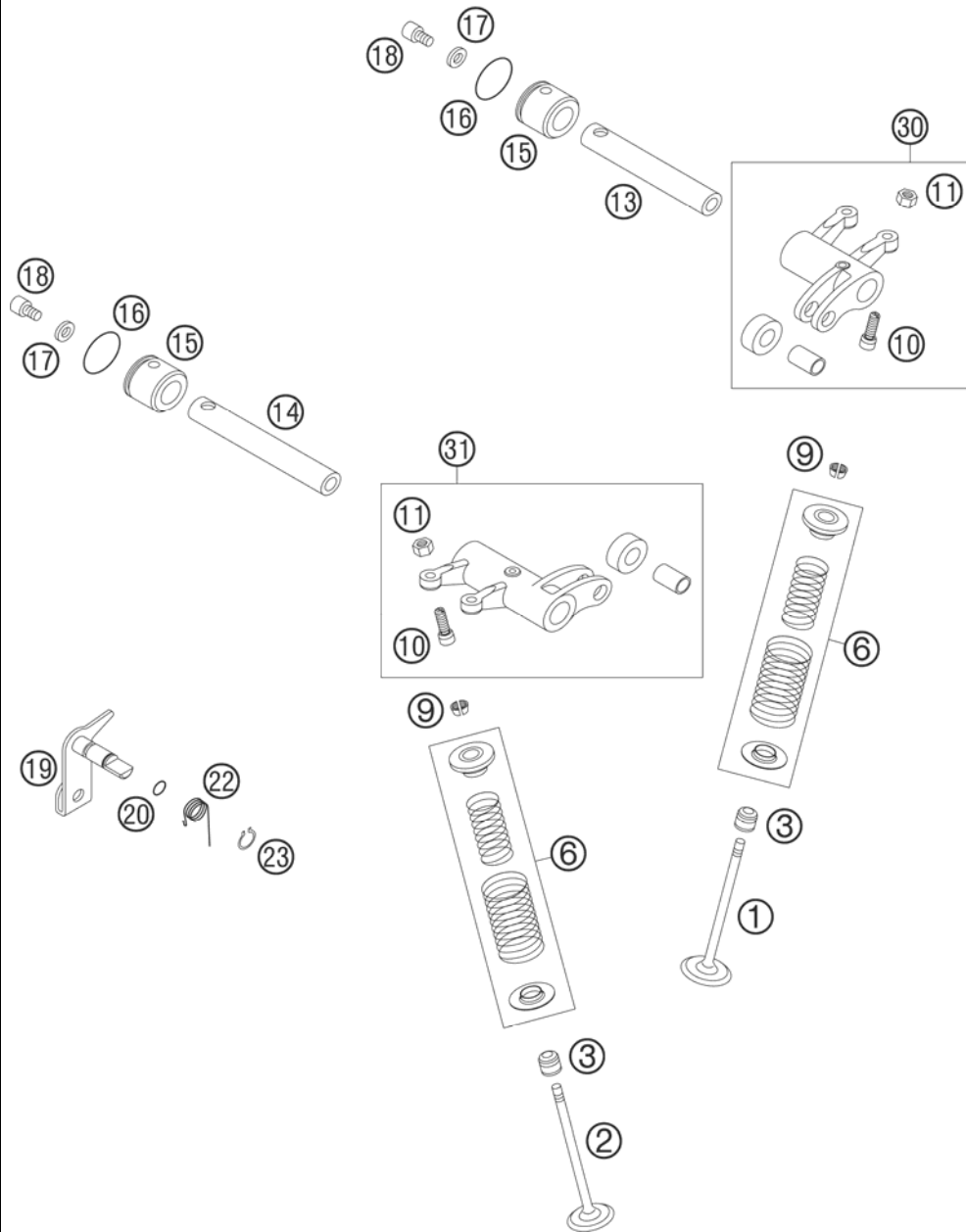

FIG	PART NUMBER	DESCRIPTION	QTY
1	5943603000	INTAKE VALVE D=35MM TITAN 03	2
2	59436031000	EXHAUST VALVE D=30MM TITAN 03	2
3	59036027000	VALVE-STEM SEALING RACING	4
6	59436128044	VALVE SPRING SET CPL. 04	4
9	59036033000	VALVE COLLET KK 6 H	8
10	59036062000	ADJUSTMENT SCREW M6X0,75	4
11	59036062100	NUT M6X0,75	4
13	59036056000	ROCKER ARM SHAFT INTAKE	1
14	59036057000	ROCKER ARM SHAFT EXHAUST	1
15	59036061095	END CAP ROCKER ARM SHAFT	2
16	0770191016	O-RING 19,10X1,60 NBR 70	2
17	59036060010	SHIM ALU 5,2X10X2	2
18	0912050083	AH SCREW DIN 912 M 5X8	2
19	59036050000	DECOMPRESSION SHAFT CPL.	1
20	0770051016	O-RING 5,10X1,60 NBR 70	1
22	59036059000	DECOMPRESSION LEVER SPRING	1
23	0471080000	CIRCLIP DIN0471- 8X0,8	1
30	59036060144	ROCKER ARM INTAKE CPL.	1
31	59036061144	ROCKER ARM EXHAUST CPL.	1

05590363 / C065903609

* NEW PART

X AS REQUIRED

TIMING VALVE

450 SX 2006

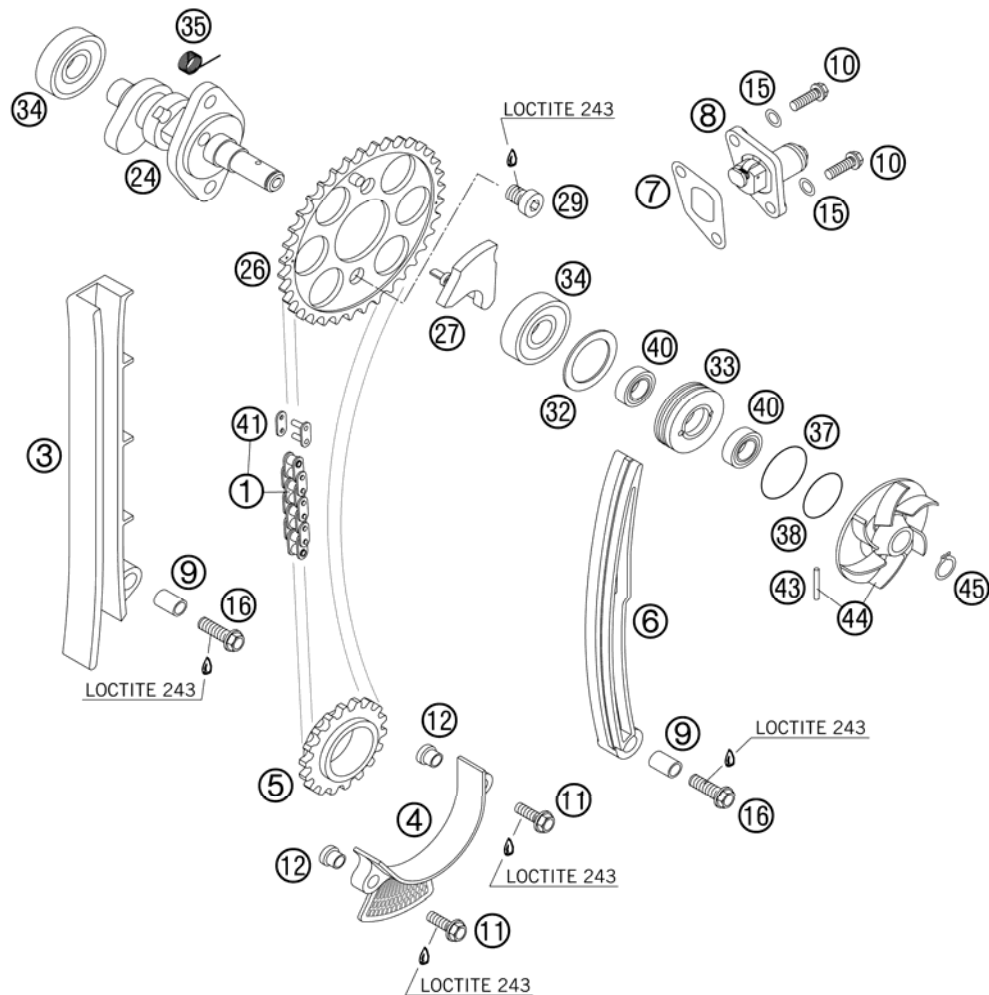

FIG	PART NUMBER	DESCRIPTION	QTY
1	59436013000	TIMING CHAIN 92 ROLLS 03	1
3	59036001000	TIMING CHAIN GUIDE RACING	1
4	59036018000	SECURING GUIDE RACING	1
5	59036014000	TIMING GEAR 18-T	1
6	59036002000	TIMING CHAIN TENSIONER	1
7	59036003050	GASKET TIMING CHAIN TENSIONER	1
8	59036003000	TIMINGCHAIN TENSIONER CPL.RAC.	1
9	59036001050	SPACER BUSHING 6,1X8,2X13,1	2
10	0015060203	HH COLLAR SCREW M 6X20 WS=8	2
11	0015050163	HH COLLAR SCREW M 5X16 WS=8	2
12	59036018050	SUPPORTING SLEEVE 5,2X7X10X7,7	2
15	0603061001	CU-SEAL RING DIN7603-6X10X1	2
16	0015060253	HH COLLAR SCREW M 6X25 WS=8	2
24	59036010000	CAMSHAFT 590/5521 2000	1
26	59036011100	CAMSHAFT GEAR 2003	1
27	59036016000	AUTO DECOMPRESSION SHAFT	1
29	0984080103	AH SCREW DIN7984-M 8X10	2
32	59036082000	WASHER 26,7X34X1,3	1
33	59036081100	GASKET SUPPORT	1
34	0625062014	BALL BEARING 6201	2
35	59036017000	SPRING FOR AUTODECOMPRESSION	1
37	0770291016	O-RING 29,10X1,60 NBR 70	1
38	0770020220	O-RING 25,12X1,78 NBR70	1
40	0760101843	SHAFT SEAL RING 10X18X4 BSL	2
41	59036013050	RIVET LINK FOR TIMING CHAIN	1
43	0402031780	NEEDLE ROL.DIN5402 NRB 3X17,8	1
44	59035055144	WATER PUMP WHEEL CPL. RAC.2001	1
45	0471100010	CIRCLIP DIN0471-10X1	1

065903602 / C065903612

* NEW PART

X AS REQUIRED

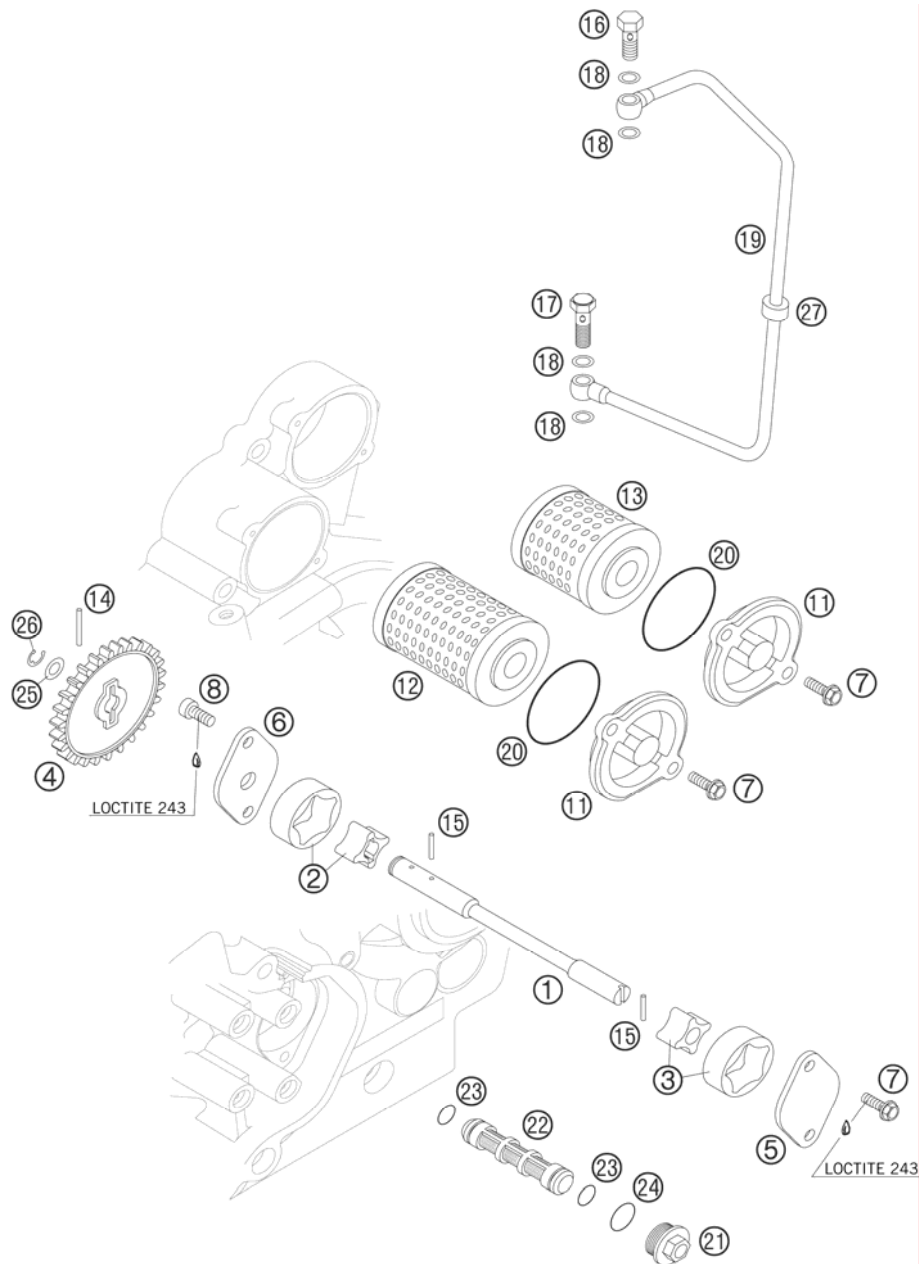

FIG	PART NUMBER	DESCRIPTION	QTY
1	59038002000	OIL PUMP SHAFT	1
2	59038011010	OILPUMP ROTOR CPL. 10MM G-73R	1
3	59038011012	OILPUMP ROTOR 12MM G-95R/003	1
4	58438001000	OIL PUMP GEAR 26-T	1
5	59038004000	OIL PUMP COVER L/S	1
6	59038003000	OIL PUMP COVER R/S 8MM	1
7	0015050163	HH COLLAR SCREW M 5X16 WS=8	6
8	0984050122	AH SCREW DIN6912-M 5X12	2
11	59038041000	OIL FILTER COVER RACING	2
12*	58038005100	OIL FILTER LONG	1
13*	59038046100	OIL FILTER SHORT	1
14	0402251980	NEEDLEROL.DIN5402 NRA 2,5X19,8	1
15	0402251180	NEEDLE ROLLER DIN5402 2,5X11,8	2
16	58038030000	BANJO BOLT M8 X 1 DIN7643	1
17	59038029000	JET SCREW "100" M8X1 WS=12	1
18	0603082121	SEAL RING CU DIN7603- 8X12X1	4
19	59438035000	OIL LINE 450 '03	1
20	0770400025	O-RING 40,00X2,50 NBR 70	2
21	59038017000	PLUG M20X1,5 WS=13	1
22	59038016000	OIL SCREEN 15X83MM	1
23	0770125015	O-RING 12,5X1,5 NBR	2
24	0770020170	O-RING 17,17X1,78 GLO	1
25	58038007755	STOP DISK 8,1 X 15 X 0,5	1
26	0799060000	TAB WASHER DIN6799-RS 6,0	1
27	58405098000	RUBBERBUFFER 8X17X10 SILENC'97	1

05590380 / C065903801

* NEW PART

X AS REQUIRED

IGNITION SYSTEM

450 SX 2006

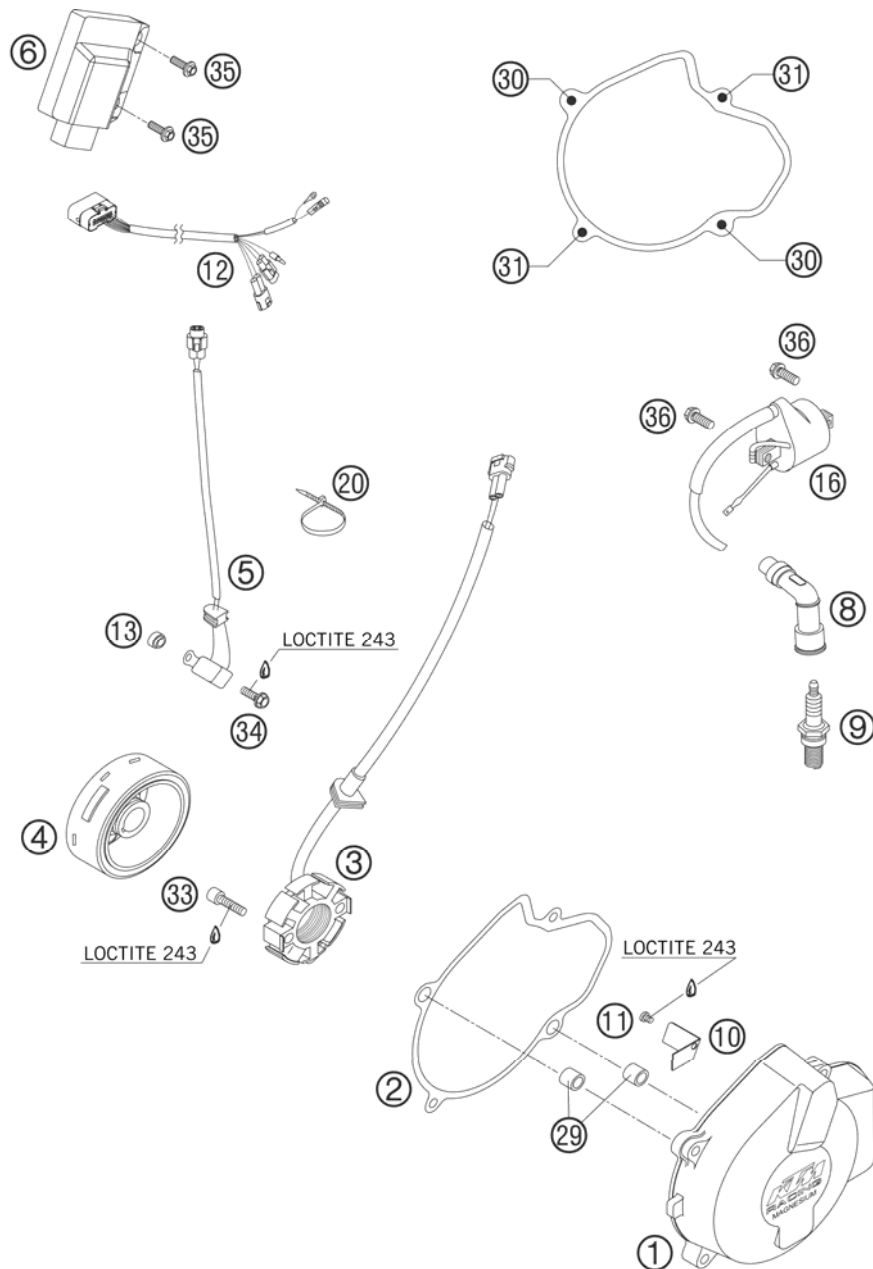
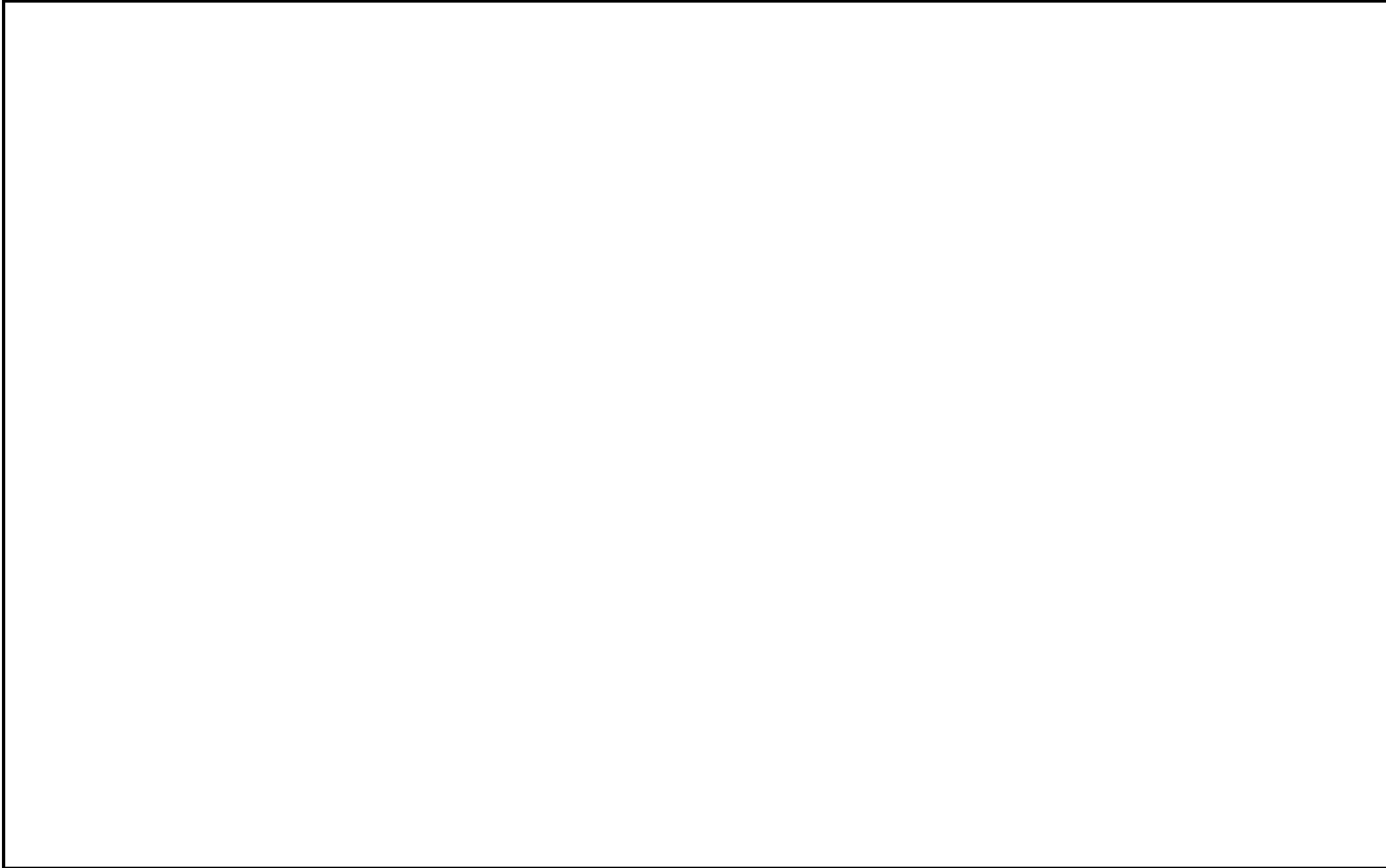

FIG	PART NUMBER	DESCRIPTION	QTY
1	59030002500	IGNITION COVER 4K3A 2000	1
2	59030040000	IGNITION COVER GASKET 0,8MM	1
3	59039004100	STATOR CPL. 4K3A RACING 2004	1
4	59039005100	FLYWHEEL 4K3A RACING 2004	1
5	59039034000	PULSER COIL KOKUSAN 4K3-A/B	1
6	59039031400	CDI UNIT 450 SX 2005	1
8	59039090100	SPARK PLUG CONNECT. VD05EG 03	1
9	59039093100	SPARK PLUG NGK DCPR8E 03	1
10	59030002050	SUPPORT FOR WIRE	1
11	0084040063	CYL.HEAD SCREW DIN0084-M 4X 6A	1
12	59439032000	WIRING HARNESS FOR CDI SX 04	1
13	59039009000	SPACER BUSHING 5,2X7X4,8 2000	2
16	59039006000	IGNITIONCOIL KOKUSAN 4K3-A/B	1
20	44011076100	CABLE TIE 100/2,5MM BLACK	x
29	49030090000	DOWEL 9,8 X 7 X 10	2
30	0015060353	HH COLLAR SCREW M 6X35 WS=8	2
31	0015060303	HH COLLAR SCREW M 6X30 WS=8	2
33	0912050253	AH SCREW DIN0912-M 5X25	2
34	0015050163	HH COLLAR SCREW M 5X16 WS=8	2
35	0014060203	HH COLLAR SCREW M 6X20 WS=8	2
36	0015060163	HH COLLAR SCREW M 6X16 WS=8	2

05590391 / C065903902

* NEW PART

X AS REQUIRED



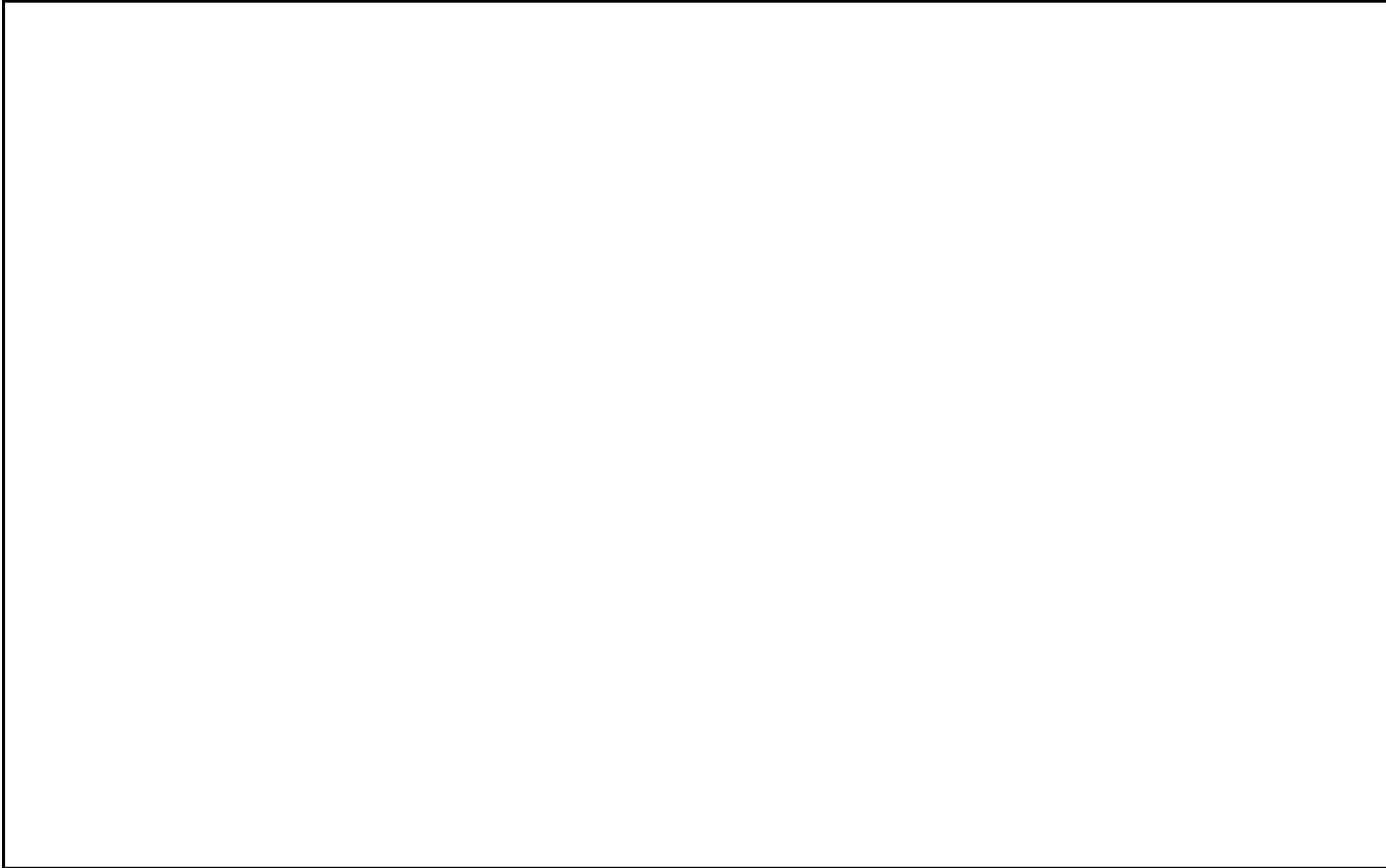

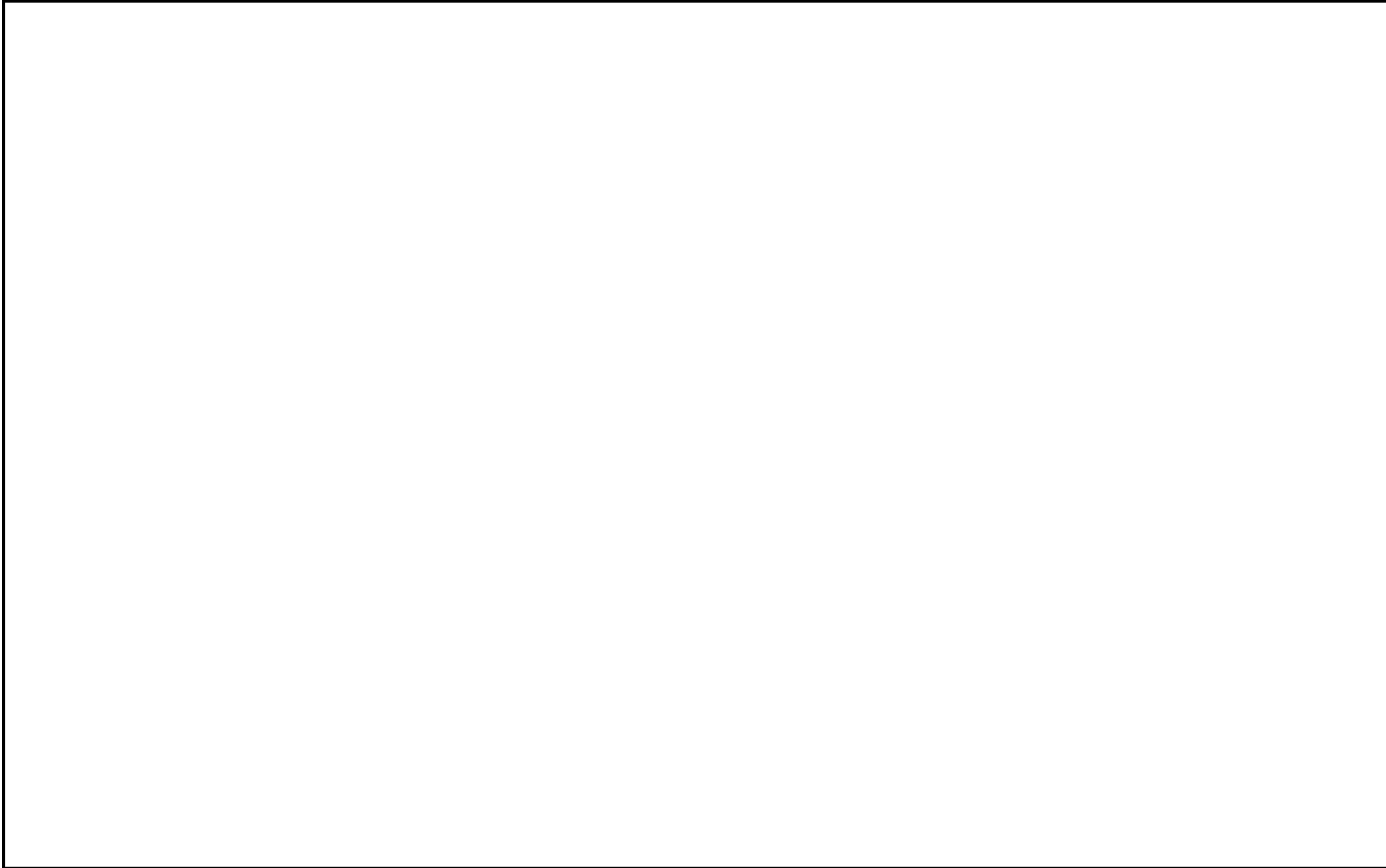



KTM Group Partner



3CM089230EN



KTM-Sportmotorcycle AG
A-5230 Mattighofen
www.ktm.at

Art.Nr.: 3CM089230EN 6/2005