

# OWNER'S MANUAL 2007

625 SXC

ART. NR. 3.211.195EN



ENGLISH

We would like to congratulate you on your purchase of a KTM motorcycle.  
You are now the owner of a state-of-the-art sport motorcycle that guarantees to bring you lots of fun and enjoyment, provided that you clean and maintain it appropriately.

Please insert the serial numbers of your motorcycle in the boxes below

Frame number

Engine number

Key number

Stamp of dealer

All information contained is without obligation. KTM-Sportmotorcycle AG particularly reserves the right to modify any equipment, technical specifications, prices, colors, shapes, materials, services, service work, constructions, equipment and the like so as to adapt them to local conditions or to cancel any of the above items, all without previous announcement and without giving reasons. KTM may stop manufacturing certain models without previous notice. KTM shall not be held liable for any deviations of availability and/or ability to deliver, illustrations, descriptions, printing and/or other errors. The illustrated models partly contain extra equipment, which is not applied to standard models.

© 2006 by KTM-SPORTMOTORCYCLE AG, Mattighofen AUSTRIA; All rights reserved; Reprint, also in extracts, with written allowance of KTM-SPORTMOTORCYCLE AG, Mattighofen only.

## CONSUMER INFORMATION FOR AUSTRALIA ONLY

Tampering with noise control system prohibited

Owners are warned that the law may prohibit:

- (a) The removal or rendering inoperative by any person other than for purposes of maintenance, repair or replacement, of any device or element of design incorporated into any new vehicle for the purpose of noise control prior to its sale or delivery to the ultimate purchaser or while it is in use; and
- (b) the use of the vehicle after such device or element of design has been removed or rendered inoperative by any person.



In accordance with the international quality management ISO 9001 standard, KTM uses quality assurance processes that lead to the highest possible product quality.

## INTENDED PURPOSE

KTM sports motorcycles are designed and constructed to resist the usual wear and tear of normal use in competitions.

The motorcycles comply with the regulations and categories currently in effect with the leading international motorcycle associations.

This motorcycle is only authorized for public roads in the original homologated (throttled) version. **Without this performance restriction (i.e. dethrottled), this motorcycle is only authorized to be driven off-road but not on public roads.** The 625 SXC model is designed for off-road endurance competitions (Enduro) and not predominantly for motocross racing.

NOTE: The above is a general statement. Specific limited warranty and limited guarantee information may vary depending upon distribution. Please check with your local KTM dealer for limited warranty and limited guarantee information specific to your KTM model and region.

## OWNER'S MANUAL

Please read this manual carefully and completely before going on your first ride. It contains a great deal of information and advice which will help you use and handle your bike properly. Only by doing so will you learn how to tune your motorcycle to your specific needs and how to protect yourself against injury. Besides, this manual contains important information on motorcycle maintenance.

In your own interest, please pay particular attention to notices that are marked as follows:

### **WARNING**

- Ignoring these instructions can be dangerous to life and limb!

### **CAUTION**

- Ignoring these instructions may damage parts of the motorcycle or impair the motorcycle's traffic safety!

At the time this manual was typeset, it was up-to-date with the latest state of this production series. It cannot be completely ruled out, however, that minor discrepancies may exist resulting from further design upgrades of these motorcycles. This manual is an important part of your motorcycle and should be passed on to any subsequent owner in case you decide to sell it.

## SERVICE

Observance of the service, maintenance and tuning instructions for the engine and chassis specified in the Owner's Manual is a prerequisite for faultless operation and the avoidance of premature wear. An improperly tuned chassis can lead to damage and breakage of the chassis components (see chapter on checking the basic chassis setting).

The use of the motorcycle under extreme conditions, e.g. on extremely muddy and wet terrain, can lead to higher than average wear on components such as the drive train or the brakes. In this case it may become necessary to service or replace wear parts before the service limit specified in the maintenance schedule has been reached.

We expressly point out that work marked with an asterisk in the chapter „Maintenance work on the chassis and engine“ must be performed. If maintenance work should become necessary during a competition it should be performed by a trained mechanic. KTM strongly recommends that all service work to your KTM should be performed by a qualified KTM dealer.

Take special care to follow the recommended run in, inspection, and maintenance intervals. Heeding these guidelines will significantly increase the life of your motorcycle.

## **WARRANTY**

The service work specified in the „Lubrication and Maintenance Schedule“ must be performed and service records must be kept for warranty documentation. Lack of proper service and maintenance records or documentation could void warranty.

No claims can be filed under the warranty for damage or consequential damage caused by manipulations or conversions to the motorcycle.

## **AUTOMOTIVE FLUIDS**

The fuels and lubricants specified in the Owner's Manual or fluids with equivalent specifications must be used in accordance with the maintenance schedule.

## **SPARE PARTS, ACCESSORIES**

For your own safety, use KTM-approved parts and accessories only. KTM is not liable for damage that arises in connection with the use of other products.

## **TRANSPORT**

When transporting your KTM, ensure that it is held upright with restraining straps or other mechanical fastening devices and that the fuel tap is in the OFF position - if the motorcycle should fall over, no fuel can leak from the carburetor or fuel tank

## **ENVIRONMENT**

Off-road motorcycle driving is a wonderful sport and we hope that you will be able to enjoy it to the full. It may, however, involve potential problems for the environment or lead to conflicts with others. These problems or conflicts can be avoided if the motorcycle is used responsibly. To safeguard the future of motorcycle sports, make sure that you use the motorcycle in accordance with the law, show that you are environmentally conscious and respect the rights of others.

We wish you a lot of fun when driving !

KTM-SPORTMOTORCYCLE AG  
5230 MATTIGHOFEN, AUSTRIA

Attachments: 1 spare parts manual chassis & engine

	Page		Page
IMPORTANT LIMITED WARRANTY AND LIMITED GUARANTEE INFORMATION	.3	Adjusting of free travel at the hand brake lever (SXC)	.29
SERIAL NUMBER LOCATIONS	.5	Changing the basic position of the handbrake lever (SMC)	.29
Chassis number	.5	General information about KTM disc brakes	.29
Engine number, engine type	.5	Checking of brake fluid level - front brake	.30
OPERATION INSTRUMENTS	.6	Refilling the front brake fluid reservoir	.30
Clutch lever	.6	Checking the front brake pads (SXC)	.31
Hand decompression lever	.6	Checking the front brake pads (SMC)	.31
Hand brake lever (SXC)	.6	Replacing front brake pads (SXC)	.31
Hand brake lever (SMC)	.6	Replacing the front brake pads (SMC)	.32
Indicator lamps	.6	Check the rear brake fluid level	.32
Electronic speedometer	.7	Refilling the rear brake fluid reservoir	.32
Overview of the electronic speedometer functions	.11	Changing the basic position of the brake pedal	.33
Ignition lock	.12	Checking the rear brake pads	.33
Combination switch	.12	Replacing the rear brake pads	.33
Flasher switch	.12	Dismounting and mounting the front wheel (SXC)	.34
Emergency OFF button	.12	Dismounting and mounting the front wheel (SMC)	.34
Filler cap	.12	Dismounting and mounting the rear wheel	.35
Fuel tap	.13	Checking the shock absorption rubbers in the rear hub (SMC)	.35
Choke	.13	Tires, air pressure	.36
Hot start device	.13	Checking spoke tension	.36
Shift lever	.13	Check/set distance of the magnetic sensor	.36
Kickstarter	.13	Battery for digital speedometer	.36
Foot brake pedal	.14	Battery (SXC)	.37
Handlebar lock	.14	Charging the battery	.37
Compression damping of fork	.15	Fuses	.38
Rebound damping of fork	.15	Replacing headlight lamp/parking light lamp	.38
Compression damping of shock absorber	.15	Exchanging the brake light and tail light bulb (SXC)	.39
Rebound damping of shock absorber	.15	Exchanging the brake light and tail light bulb (SMC)	.39
GENERAL TIPS AND WARNINGS FOR STARTING THE MOTORCYCLE	.16	Checking the coolant level	.40
Instructions for initial operation	.16	Cooling system	.40
Running in the LC4 models	.16	Cleaning the air filter (SXC)	.41
Accessories and payload	.16	Cleaning of air filter	.41
DRIVING INSTRUCTIONS	.17	Exhaust system (SXC)	.42
Check the following before each start	.17	Exhaust system (SMC)	.42
Starting when the engine is cold	.18	Adjusting the throttle cable	.43
Starting when the engine is warm or hot	.18	Checking the adjustment of the hand decompression cable	.43
What to do when the engine is "flooded"	.18	Changing the original position of the clutch lever	.44
Kickstart instructions	.18	Checking the oil level of the hydraulic clutch	.44
Starting off	.18	Bleeding of the hydraulic clutch	.44
Shifting/Riding	.19	Activating the ignition curve for low-octane fuel	.45
Stopping and parking	.19	Draining the float chamber of the carburetor	.45
Braking	.19	CARBURETOR – Adjust idling	.45
Fuel	.20	Adjusting the mixture control screw	.46
PERIODIC MAINTENANCE SCHEDULE	.21	Checking the float level (float height)	.46
MAINTENANCE WORK ON CHASSIS AND ENGINE	.23	Engine oil	.46
Removal of seat (SXC)	.23	Checking the engine oil level	.46
Tool set (SXC)	.23	Oil circuit	.47
Removal of seat (SMC)	.24	Oil and screen filter change, bleeding of the oil system	.47
Tool set (SMC)	.24	Changing oil filter	.48
Check and adjust steering head bearing	.24	TROUBLE SHOOTING	.49
Breather plug front fork	.25	CLEANING	.51
Cleaning the dust sleeves of the telescopic fork	.25	CONSERVATION FOR WINTER OPERATION	.51
How to change the handlebar position	.25	STORAGE	.51
Changing the spring preloading of the shock absorber	.26	Reinitiation after time of storage	.51
Checking rubber ring on the WP rear shock absorber	.26	TECHNICAL SPECIFICATIONS – ENGINE	.52
Lubricate rear suspension linkage	.26	Engine oil	.52
Correct chain tension	.27	TECHNICAL SPECIFICATIONS - CHASSIS	.54
Checking chain tension	.27	HEAD WORD INDEX	.56
Chain wear	.28	WIRING DIAGRAM	.appendix
Chain maintenance	.28		

## SERIAL NUMBER LOCATIONS »

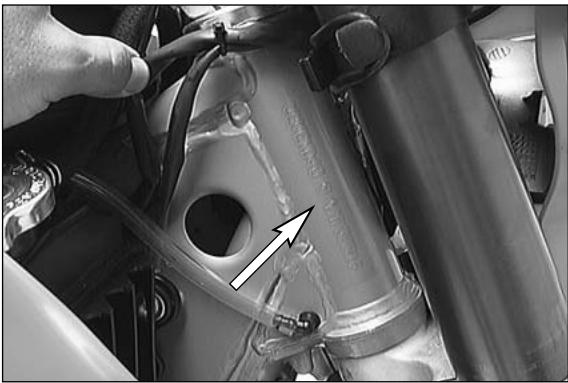

### Chassis number

The chassis number is stamped on the right side of the steering head tube. Write this number into the relevant area on page 1.

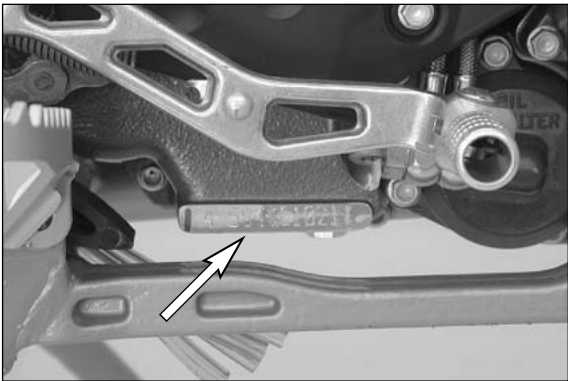

### Engine number, engine type

The engine number and engine type are stamped on the right hand side of the engine below the chain sprocket. Write this number into the relevant area on page 1.

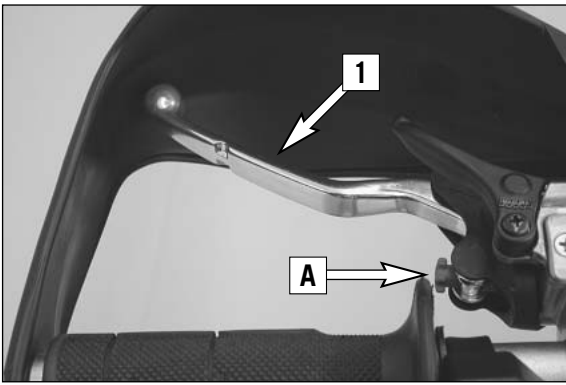

## Clutch lever

The clutch lever [1] is located on the left side of the handlebar. The adjusting screw [A] is used to change the original position of the clutch lever (see maintenance work on chassis and engine).

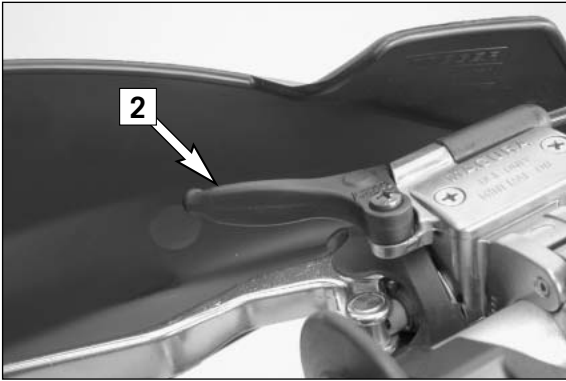

## Hand decompression lever

The hand decompression lever [2] is only used in two special cases:

a) When the engine stalled.

It is possible that the starter motor is not able to crank the engine on the next attempt. This is due to the fact that the automatic decompressor doesn't work properly. If this happens, pull the manual decompression lever and start again. Afterwards normal starting will be possible.

b) When you want to push the motorcycle.

While pushing, pull the hand decompression lever to make it easier to get the engine going.

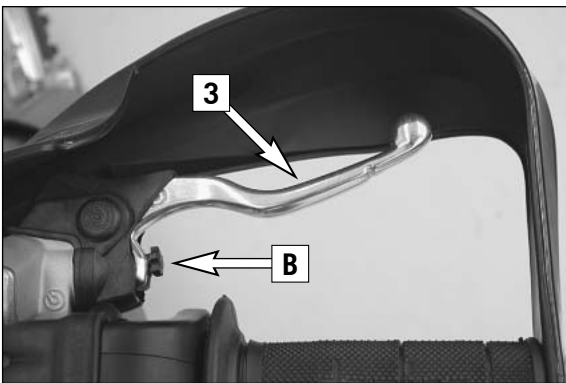

## Hand brake lever (SXC)

The hand brake lever [3] is mounted on the handlebars on the right and actuates the front wheel brake. The adjusting screw [B] can be used to change the basic position of the hand brake lever (see "Maintenance").

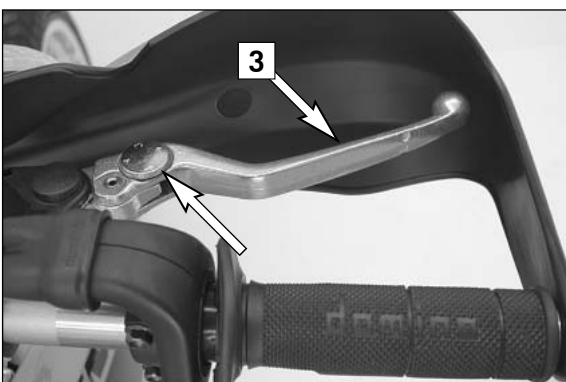

## Hand brake lever (SMC)

The hand brake lever [3] is mounted on the right side of the handlebar. The basic position of the handbrake lever can be changed in 4 steps (see Maintenance work).

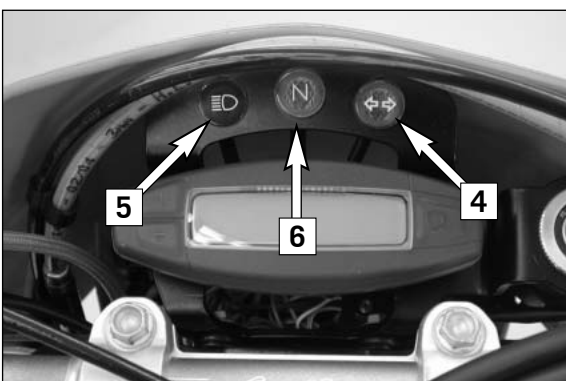

## Indicator lamps



The green control lamp [4] flashes when the indicator is working in the same rhythm as the flashing indicator.



The blue control lamp [5] lights up when the high beam is on.



The green indicator lamp [6] lights up when the neutral gear is selected.

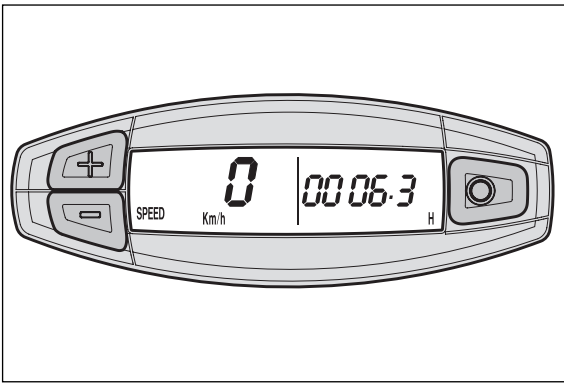

## Electronic speedometer

The display in the electronic speedometer is activated as soon as you press a button on the speedometer or an impulse is received from the wheel sensor. The display lights up when the engine is running.

The display is cleared if no button is pressed for 1 minute or no impulse is received from the wheel sensor.

The **0** button is used to change between display modes.

The **+** and **-** buttons are used to control various functions.

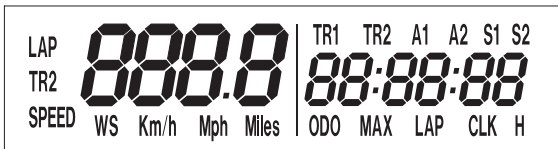

## TEST

All of the display segments briefly light up for the display function test.



## WS (wheel size)

The display changes and the circumference of the front wheel is briefly displayed in millimeters (2205 mm corresponds to a front wheel circumference of 21" with production tires).

Afterwards the display will return to the previous display mode.



## SPEED display mode / H (service hours)

Only the SPEED / H and SPEED / ODO display modes are activated in the condition at delivery. SPEED/H is displayed whenever the display is activated and the front wheel is not turning. It automatically changes to the SPEED/ODO display mode as soon as the front wheel starts turning.

SPEED displays the speed.

H displays the engine's service hours. The service hour counter starts to count as soon as you start the engine. The displayed figure cannot be changed.

Service intervals are indicated in service hours for some KTM offroad motorcycles, making the service hour counter a very practical function.

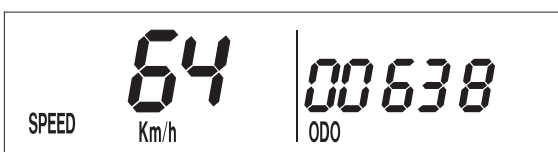

## SPEED / ODO display mode (odometer)

The SPEED/ODO mode displays the speed and the total distance traveled. The display automatically changes to the SPEED/H display mode when the front wheel stops turning.

- |                               |                                  |
|-------------------------------|----------------------------------|
| <b>+</b> button               | no function                      |
| <b>-</b> button               | no function                      |
| briefly press <b>0</b> button | changes to the next display mode |
| hold <b>0</b> button 3 secs.  | changes to the next display mode |

The electronic speedometer has a number of display modes (functions) that you can also activate (reveal) (see: Activating and deactivating display modes).



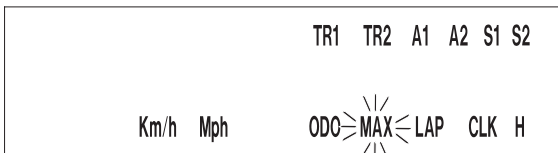

## Activating and deactivating display modes

In the display mode SPEED/H, press and hold the **○** button for 3 seconds to access the SETUP menu. The active functions will be displayed. The blinking function can be activated by pressing the **+** button and deactivated by pressing the **-** button.

Press and hold the **○** button 3 seconds to store the settings.

If no button is pressed for 20 seconds, the setting will be stored automatically and the display will return to the SPEED/H mode.

<b>+</b> button	activates the blinking display
<b>-</b> button	deactivates the blinking display
briefly press <b>○</b> button	changes to the next display without changing any settings
hold <b>○</b> button 3 secs.	starts the SETUP stores the settings and changes to the SPEED/H mode

The following display modes can be activated:

TR1	tripmaster 1
TR2	tripmaster 2
A1	average speed 1
A2	average speed 2
S1	stop watch 1
S2	stop watch 2
CLK	clock
LAP	lap time
MAX	maximum speed
KMH/MPH	display in kilometers or miles (see: Kilometers or miles)

If you have activated all of the display modes, they will be displayed in the following order:

SPEED/H, SPEED/CLK, SPEED/LAP, LAP/LAP, SPEED/MAX, SPEED/ODO, SPEED/TR1, SPEED/TR2, SPEED/A1, SPEED/A2, SPEED/S1, SPEED/S2

## SPEED / CLK (time) display mode

CLK displays the time in hours, minutes and seconds.

<b>+</b> button	no function
<b>-</b> button	no function
briefly press <b>○</b> button	changes to the next display mode
hold <b>○</b> button 3 secs.	set the clock menu

To set the clock, see „Setting the clock“.



## SPEED / LAP (lap time) display mode

You can use the manual stop watch to stop and store up to 10 lap times, which you can view in the LAP/LAP display mode (see below).

LAP displays the lap times in hours, minutes and seconds.

<b>+</b> button	Starts and stops the stop watch, lap time is not reset to 0
<b>-</b> button	Stops the stop watch, stores the lap time and restarts the stop watch again. The time is reset to 0. A total of 10 lap times can be stored. If the lap time continues to run after you press the - button, all 10 memory locations are occupied. To clear all of the stored lap times, hold the <b>○</b> button for 3 seconds in the SPEED/LAP mode. Up to 10 lap times can be stored in this way.
briefly press <b>○</b> button	Changes to the next display mode. If no lap time is stored or the motorcycle is driving, the LAP/LAP mode will be skipped.
hold <b>○</b> button 3 secs.	Clears all LAP figures





## LAP / LAP display mode (to view lap times)

The LAP/LAP display mode will only be shown if lap times have been stored and the front wheel has stopped. It will display the lap number and the stopped lap time in hours, minutes and seconds. Press the + button to access the next lap time.

To clear all of the stored lap times, hold the **○** button for 3 seconds in the SPEED/LAP mode.

- |                               |                                  |
|-------------------------------|----------------------------------|
| + button                      | changes to the next lap time     |
| - button                      | no function                      |
| briefly press <b>○</b> button | changes to the next display mode |
| hold <b>○</b> button 3 secs.  | changes to the next display mode |



## SPEED / MAX display mode (maximum speed)

MAX displays the maximum speed traveled and is always active.

- |                               |                                  |
|-------------------------------|----------------------------------|
| + button                      | no function                      |
| - button                      | no function                      |
| briefly press <b>○</b> button | changes to the next display mode |
| hold <b>○</b> button 3 secs.  | clears the MAX figure            |

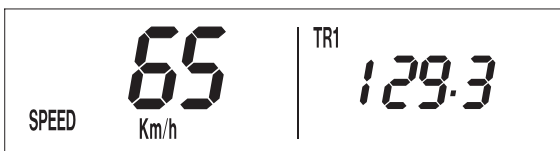

## SPEED / TR1 display mode (tripmaster 1)

The TR1 tripmaster is always active and counts to 999.9. It is used to measure the length of a trip or the distance between 2 refueling stops.

TR1 is linked to A1 (average speed 1). The calculation of these figures is activated by the first impulse received from the wheel sensor (when the front wheel starts to turn) and stops 3 seconds after the last impulse is received (when the front wheel has stopped).

The TR1, A1 and S1 figures are automatically cleared after passing 999.9.

- |                               |                                  |
|-------------------------------|----------------------------------|
| + button                      | no function                      |
| - button                      | no function                      |
| briefly press <b>○</b> button | changes to the next display mode |
| hold <b>○</b> button 3 secs.  | clears the TR1, S1, A1 figures   |



## SPEED / TR2 display mode (tripmaster 2)

The tripmaster 2 is always active and counts to 999.9. Contrary to TR1, the displayed figure can be changed using the + and - buttons. This is a very useful function for trips taken according to a roadbook.

- |                               |                                  |
|-------------------------------|----------------------------------|
| + button                      | increases the TR2 figure         |
| - button                      | decreases the TR2 figure         |
| briefly press <b>○</b> button | changes to the next display mode |
| hold <b>○</b> button 3 secs.  | clears the TR2 figure            |



## SPEED / A1 display mode (average speed 1)

A1 shows the average speed based on the TR1 (tripmaster 1) and S1 (stop watch 1) figures. The calculation of this figure is activated by the first impulse received from the wheel sensor and stops 3 seconds after the last impulse is received.

- |                               |                                  |
|-------------------------------|----------------------------------|
| + button                      | no function                      |
| - button                      | no function                      |
| briefly press <b>○</b> button | changes to the next display mode |
| hold <b>○</b> button 3 secs.  | clears the TR1, S1, A1 figures   |



## SPEED / A2 display mode (average speed 2)

A2 shows the average speed based on the TR2 (tripmaster 2) and S2 (stop watch 2) figures.

The displayed figure can deviate from the actual average speed if the TR2 figure was changed manually or if S2 was not stopped after the trip.

- + button no function
- button no function
- briefly press **○** button changes to the next display mode
- hold **○** button 3 secs. changes to the next display mode



## SPEED / S1 display mode (stop watch 1)

S1 shows the traveling time based on TR1 and continues to run whenever it receives impulses from the wheel sensor. The calculation of this figure is activated by the first impulse received from the wheel sensor and stops 3 seconds after the last impulse is received.

- + button no function
- button no function
- briefly press **○** button changes to the next display mode
- hold **○** button 3 secs. clears the TR1, S1, A1 figures



## SPEED / S2 display mode (stop watch 2)

S2 is a manual stop watch. Start the stop watch by pressing the + button, press again to hold. Press again to continue timing.

Press the **○** button to change to the next mode. The S2 display will blink in the other modes if S2 continues to run in the background. To stop S2, return to the SPEED/S2 mode and press the + button.

- + button starts and stops the stop watch
- button no function
- briefly press **○** button changes to the next display mode
- hold **○** button 3 secs. clears the S2 figure

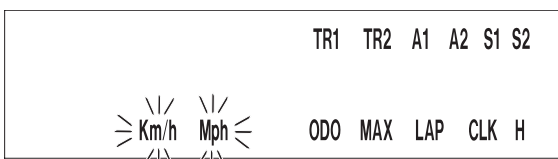

## Kilometers or miles

The unit (kilometers or miles) can also be changed. The ODO figure will be retained and converted accordingly. The TR1, A1, S1, TR2 and A2 figures will be cleared.

To select the unit, select the SPEED/H mode and hold the **○** button for 3 seconds to access the SETUP menu. Press the **○** button until the KMH/MPH function blinks. Press the + button briefly to move to the options. Press the + button for KMH or the - button for MPH.

To set, briefly press the **○** button 1 x and hold for 3 seconds until the display returns to the SPEED/H mode.

If no button is pressed for 20 seconds, the setting will be stored automatically and the display will return to the SPEED/H mode.

- + button to access the menu
- button to activate the KMH display
- briefly press **○** button to activate the MPH display
- changes to the next mode
- changes from the menu to the SETUP menu
- hold **○** button 3 secs. stores and closes the SETUP menu

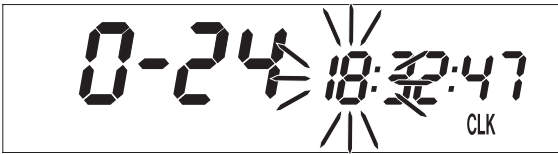

## Setting the clock

To set the clock, switch the ignition off and select the SPEED/CLK mode. Press and hold the **○** button for 3 seconds. The blinking digits can be changed using the + and - buttons. Press the **○** button to move to the next digit. 0-12 will show the time in the 12-hour mode, 0-24 in the 24-hour mode. Press and hold the **○** button for 3 seconds to store the settings. If no button is pressed for 20 seconds, the settings will be stored automatically and the display will return to the SPEED/CLK mode.

- |                               |   |
|-------------------------------|---|
| + button                      | time +  |
| - button                      | time -  |
| briefly press <b>○</b> button | changes to the next digit                                 |
| hold <b>○</b> button 3 secs.  | starts the SETUP menu                                     |
|                               | stores the time and changes to the SPEED/CLK display mode |

Motorcycle is standing	Motorcycle is driving	OVERVIEW OF THE ELECTRONIC SPEEDOMETER FUNCTIONS				
		display	briefly press + button	briefly press - button	briefly press <b>○</b> button	hold <b>○</b> button 3 secs.
X		<b>SPEED / H</b>	no function	no function	next display mode	displays the SETUP menu
X	X	<b>SPEED / CLK</b>	no function	no function	next display mode	Setting the clock menu
X	X	<b>SPEED / LAP</b>	starts/stops LAP without clearing LAP figure	stops LAP, stores LAP figure, resets LAP to 0	next display mode	clears all LAP figures
X		<b>LAP / LAP</b>	next figure	no function	next display mode	next display mode
X	X	<b>SPEED / MAX</b>	no function	no function	next display mode	clears MAX
	X	<b>SPEED / ODO</b>	no function	no function	next display mode	next display mode
X	X	<b>SPEED / TR1</b>	no function	no function	next display mode	clears TR1, S1, A1
X	X	<b>SPEED / TR2</b>	increases the TR2 figure	reduces the TR2 figure	next display mode	clears TR2
X	X	<b>SPEED / A1</b>	no function	no function	next display mode	clears TR1, S1, A1
X	X	<b>SPEED / A2</b>	no function	no function	next display mode	next display mode
X	X	<b>SPEED / S1</b>	no function	no function	next display mode	clears TR1, S1, A1
X	X	<b>SPEED / S2</b>	starts - stops S2	no function	next display mode	clears S2

If the CLK, LAP, MAX, TR1, TR2 A1, A2, S1 and S2 figures are suddenly cleared, the battery in the electronic speedometer is empty and must be replaced (see: Replacing the battery in the electronic speedometer).

A tripmaster switch is available as an accessory that lets you control the electronic speedometer functions from the handlebar.

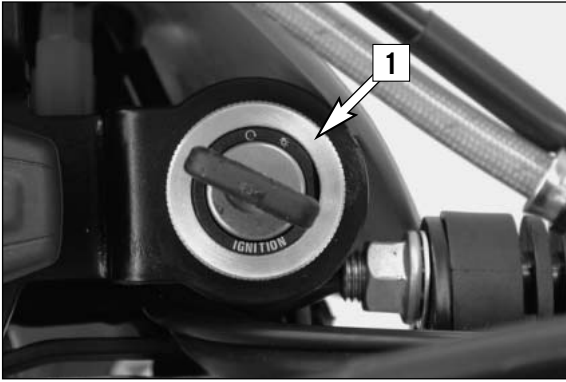

## Ignition lock

Switch positions of ignition lock [1]:

 = Ignition off, light off (engine can't be started)

 = Ignition on, light off (engine can be started)

 = Ignition on, light on (engine can be started)

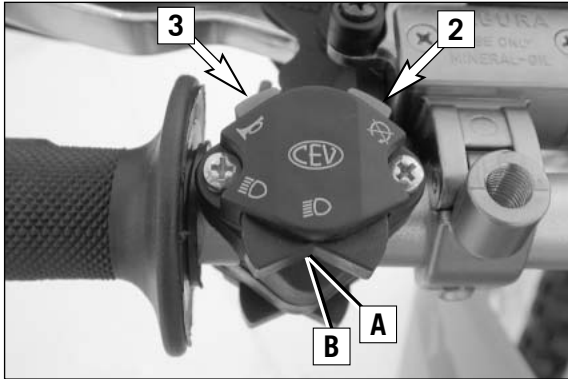

## Combination switch

The light switch has 2 switch positions.

[A] = Low beam light

[B] = High beam light

The red short circuit button [2] serves to switch off the engine. Leave the switch pressed, until the engine stops. With the button [3] the horn will sound.

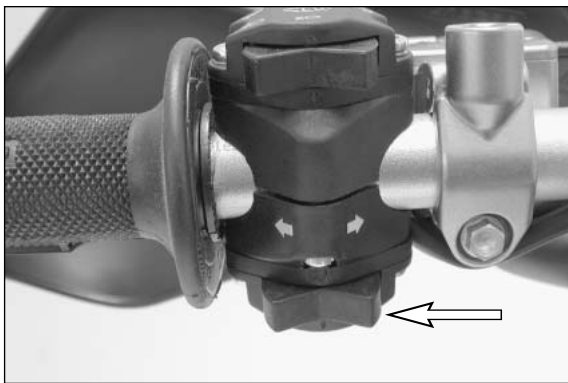

## Flasher switch

The flasher switch is a separate unit and is mounted on the left portion of the handlebar.

The wire harness is designed in a way that whenever you want to use your bike off-road, you can dismount the entire turn indicator system without affecting the function of the remaining electrical system.

 Flasher left

 Flasher right

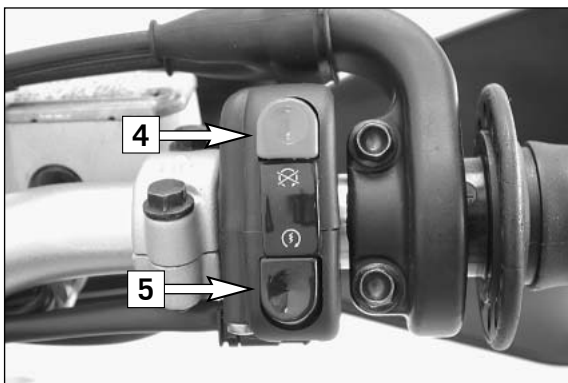

## Emergency OFF button

 The red emergency-OFF button [4] is arranged adjacent to the throttle grip. To turn off the engine, push the button until the engine comes to a standstill.

 Pushing the black starter button [5] will actuate the E-starter.



## Filler cap

To open filler cap: Turn the filler cap counter-clockwise.  
To close filler cap: Screw on the filler cap clockwise.

Install tank breather hose [6] without kinks.

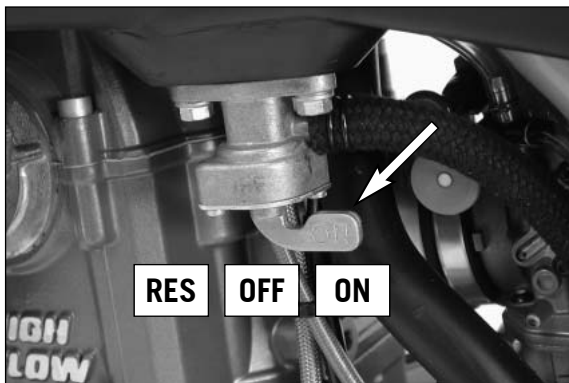

## Fuel tap

**OFF** In this position the fuel tap is closed. No fuel may flow to the carburetor.

**ON** When using the motorcycle, the rotating handle must be set to the ON position. Now fuel may flow to carburetor. In this position the tank empties down to the fuel reserve of approx. 2,5 liters.

**RES** The reserve tank, approximately 2,5 liters, cannot be tapped until the rotating handle is turned to the RES position. Fill the tank as soon as possible and remember to turn the rotating handle back to the ON position so that you will have backup fuel next time, too.

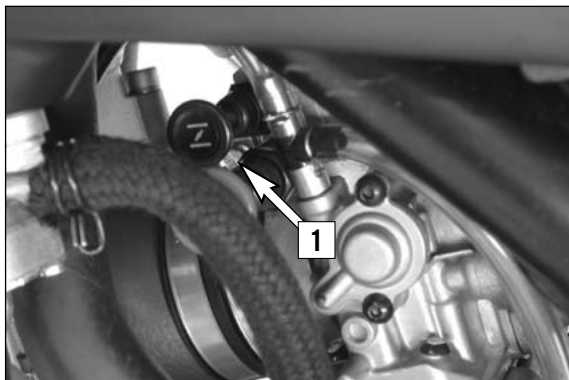

## Choke

If you pull the choke button [1] out as far as possible, a bore in the carburetor will be opened through which the engine may take in additional fuel. The result is a „fat“ fuel-air mixture of the type needed for cold starts.

To deactivate the choke, push the choke button back into its basic position.

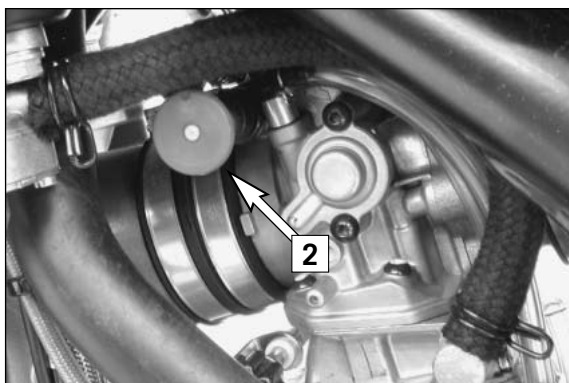

## Hot start device

If you pull the hot start device [2] out as far as possible, a bore in the carburetor will be opened through which the engine may take in additional air. The result is a „lean“ fuel-air mixture of the type needed for hot starts.

To deactivate the hot start device, push the hot start button back into its basic position.

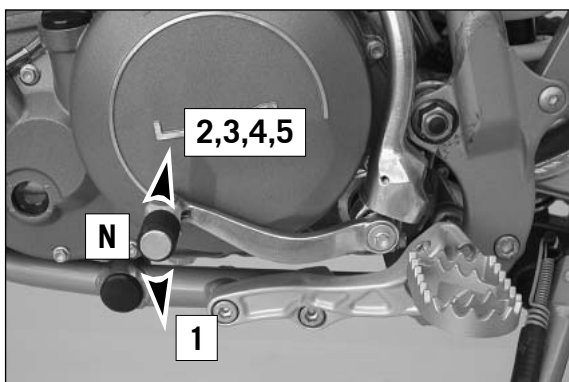

## Shift lever

The shift lever is mounted on the left side of the engine. The position of the gears is shown in the illustration. Neutral position is located between first and second gear.



## Kickstarter

The kickstarter is mounted on the left side of the engine. Its upper part can be swivelled.



### Foot brake pedal

The foot brake pedal is located in front of the right foot rest. Its basic position can be adjusted to your seat position (see maintenance work).



### Handlebar lock

The handlebar can be locked by means of the lock located on the control head. Fully turn handlebar to right to lock, insert key, turn to left, press in, turn to right and withdraw.

#### **!** CAUTION

Never leave the key inserted in the lock. If you turn the steering to the left the key could get damaged.



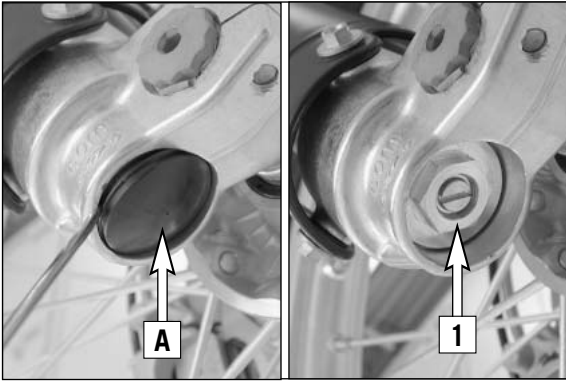

## Compression damping of fork

The compression damping is to be set at the lower end of the fork tubes. It only regulates the degree of damping during compression. Remove closing cap [A]. By using the knob [1] (COM), the degree of damping of the compression can be adjusted. Turn the knob clockwise to increase damping, turn it counterclockwise to reduce damping during compression.

### STANDARD ADJUSTMENT:

- turn adjusting screw clockwise as far as it will go
- turn it back by as many clicks as are specified for the relevant type of fork

WP 05187B01 .....20 clicks  
 WP 14187B07 .....23 clicks

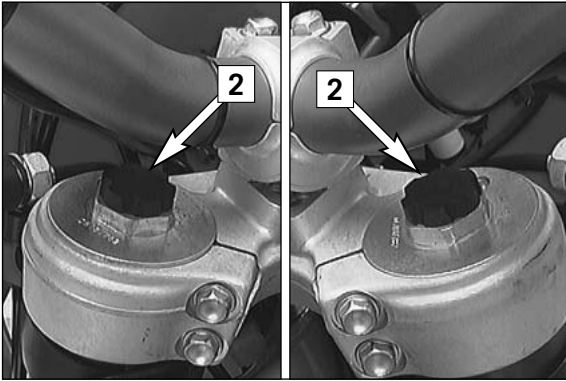

## Rebound damping of fork

Hydraulic rebound damping determines the reaction when the fork is rebound. By turning the knob [2], the degree of damping of the rebound can be adjusted. Turn the knob clockwise to increase damping, turn it counterclockwise to reduce damping during rebounding.

### STANDARD ADJUSTMENT:

- turn adjusting screw clockwise as far as it will go
- turn it back by as many clicks as are specified for the relevant type of fork

WP 05187B01 .....12 clicks  
 WP 14187B07 .....19 clicks

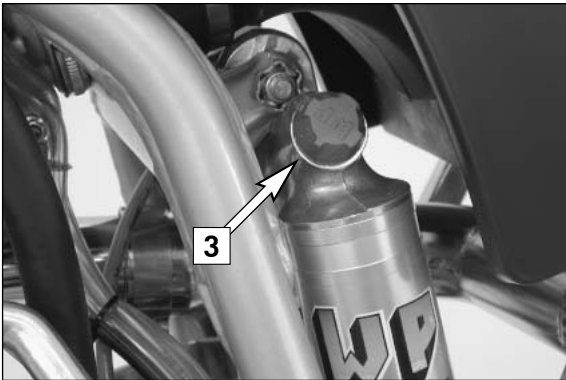

## Compression damping of shock absorber

With the knob [3] the degree of damping of the compression can be adjusted. Turn the knob counterclockwise to increase damping, turn it clockwise to reduce damping during rebounding.

### STANDARD ADJUSTMENT:

WP 01187B01 ..... position 3  
 WP 01187B02 ..... position 4

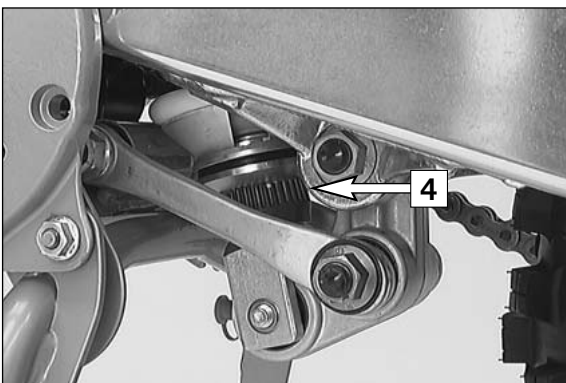

## Rebound damping of shock absorber

With the setting wheel [4] the degree of damping of the rebound can be adjusted. Turn the knob to the left side to increase damping, turn it to the right side to reduce damping during rebounding.

### STANDARD ADJUSTMENT:

WP 01187B01 ..... position 5  
 WP 01187B02 ..... position 8



## Instructions for initial operation

- Make sure the work for the "pre-delivery inspection" was performed by your authorized KTM workshop. The DELIVERY CERTIFICATE and SERVICE MANUAL will be handed over when you pick up your vehicle.
- Read these operating instructions carefully before your first ride.
- Enter the chassis, engine and key numbers on page 1.
- Familiarize yourself with the operating elements.
- Adjust the hand brake lever and foot brake lever to your most comfortable position.
- Get used to handling the motorcycle on an empty parking lot or open space, before starting on a longer drive. Also try to drive as slowly as possible and in standing position, to improve your feeling for the vehicle.
- Do not drive along off-road tracks which go beyond your ability and experience.
- Hold the handlebars with both hands and leave your feet on the foot rests while driving.
- Remove your foot from the foot brake lever when you are not braking. If the foot brake lever is not released the brake pads rub continuously and the braking system is overheated.
- Do not make any alterations to the motorcycle and always use ORIGINAL KTM SPARE PARTS. Spare parts from other manufacturers can impair the safety of the motorcycle.
- Motorcycles are sensitive to alterations in the distribution of weight. If you are taking luggage with you, this should be secured as close as possible to the middle of the vehicle; distribute the weight evenly between the front and rear wheel. Never exceed the maximum permissible laden weight and the axle weights. The maximum permissible laden weight is made up of the following components:
  - Motorcycle ready for operation and tank full
  - Luggage
  - Driver with protective clothing and helmet.
- Pay attention to running-in procedure.

## Running in the LC4 models

Even very precisely machined sections of engine components have rougher surfaces than components which have been sliding against one another for quite some time. Therefore, every engine needs to be broken in. For this reason, during its first 1000 kilometers (620 miles) the engine must not be revved up to its performance limits. The engine speed of 4800 r.p.m. must not be exceeded during the first 1000 kilometers (620 miles). During this break-in time, you should ride your motorcycle in different conditions (roads, easy off-road terrain). The following table shows you the maximum velocity values in the different gears at 4800 r.p.m. as based on the rear wheel transmission ratio of your motorcycle.

ratio gear	625 SXC 16:40 Z	625 SMC 17:40 Z
1. G	35 kmh	35 kmh
2. G	55 kmh	60 kmh
3. G	80 kmh	80 kmh
4. G	95 kmh	100 kmh
5. G	110 kmh	115 kmh

### NOTE:

During the stage of running the engine in, that is the first 1000 KM (620 miles), the engine oil used should be of a mineral oil formula. This also applies if the engine has been repaired.

## ⚠ WARNING

- Wear suitable clothing when driving a motorcycle. Clever KTM drivers always wear a helmet, boots, gloves and a jacket, regardless of whether driving all day or just for a short trip. The protective clothing should be brightly colored so that other vehicle can see you as early as possible.
- Do not drive after having consumed alcohol.
- Always turn on the light to make sure that other drivers become aware of you as early as possible.
- Only use accessories that have been released by KTM. For example, front panelling can impair the driving properties of the motorcycle. Cases, extra tanks etc. can alter the weight distribution and thus also impair the vehicles driving properties.
- The front and rear wheel are allowed to be fitted only with tires that have the same profile type.
- Observe the traffic regulations, drive defensively and trying to look ahead as far as possible so that any hazards can be recognized as early as possible.
- Choose your driving speed according to the conditions and your driving skills.
- Drive carefully on unknown roads or on unfamiliar trials.
- renew the vizor on your helmet or the glass of your goggles on time so as to ensure optimum vision in any situation. When light shines directly on scratched vizor or goggles, the operator will be blinded.
- Never leave your motorcycle without supervision if the engine is running.
- The 625 SXC is designed and built for one person only - no additional passenger allowed!
- When riding your motorcycle, please bear in mind that other people may feel molested by excessive noise.

## Accessories and payload

Accessory parts and baggage can significantly decrease a motorcycle's driving stability. Please observe the following warnings.

## ⚠ WARNING

- If you have cases mounted, do not exceed the manufacturer's recommended maximum payload.
- Fasten the baggage close to the center of the motorcycle and distribute the weight evenly on the front and rear wheels and on the left and right.
- Baggage must be securely and adequately fastened; loose baggage will significantly impair driving safety.
- A high payload will change the motorcycle's handling and considerably increase the braking distance; adapt your driving speed accordingly.

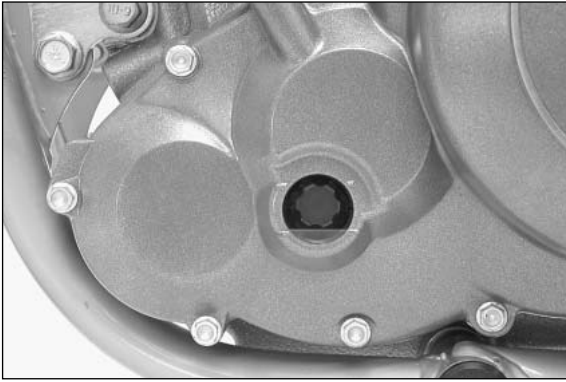

## Check the following before each start

When you start, the motorcycle must be in perfect mechanical condition. For safety reasons, you should make a habit of performing an overall check of your motorcycle before each start.

The following checks should be performed:

- 1 CHECK OIL LEVEL**  
Insufficient oil results in premature wear and consequently to engine damage.
- 2 FUEL**  
Check that there is sufficient fuel in the tank; when closing the filler cap, check that the tank venting hose is free of kinks.
- 3 CHAIN**  
A loose chain can fall from the chain wheels; an extremely worn chain can tear, and insufficient lubrication can result in unnecessary wear of chain and chain wheels.
- 4 TIRES**  
Check for damaged tires. Tires showing cuts or dents must be replaced. The tread depth must comply with the legal regulations. Also check the air pressure. Insufficient tread and incorrect air pressure deteriorate the driving performance.
- 5 BRAKES**  
Check correct functioning of the braking system. Check for sufficient brake fluid in the reservoir. The reservoirs have been designed in such a way that brake fluid does not need to be refilled even when the brake pads are worn. If the level of brake fluid falls below the minimum value, this indicates a leak in the braking system or completely worn out brake pads. Arrange for the braking system to be checked by a KTM specialist, as complete failure of the braking system can be avoided. Also check the state of the brake hose and the thickness of the brake linings. Check free travel at hand brake lever and foot brake lever.
- 6 CABLES**  
Check correct setting and smooth operation of all control cables.
- 7 COOLING FLUID**  
Check the level of cooling fluid when the engine is cold.
- 8 ELECTRICAL SYSTEM**  
Check correct operation of headlamps, tail-lights, brake lights, indicators, control lamps and horn while the engine is running.
- 9 LUGGAGE**  
If you are taking luggage with you, check that this is securely fastened.



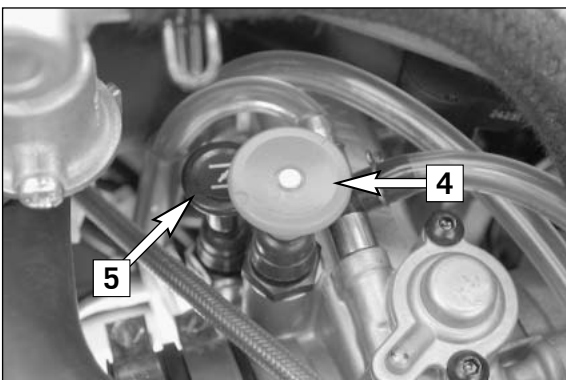
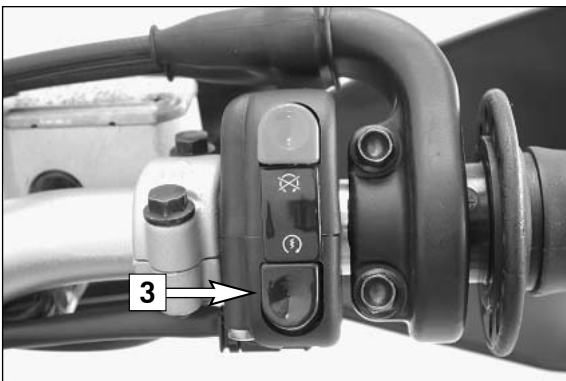
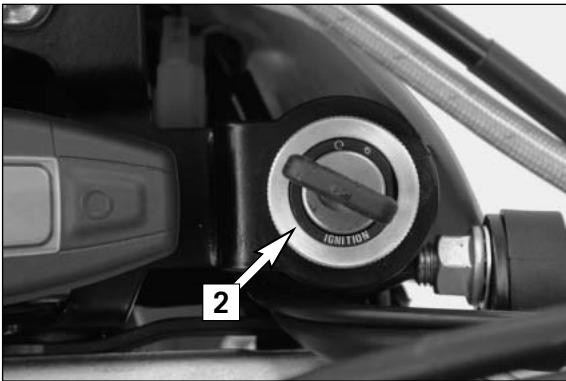
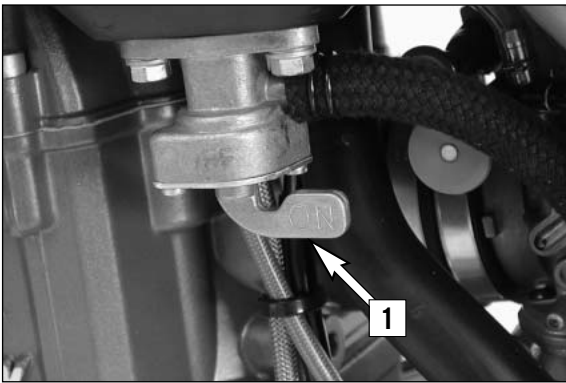

## Starting when the engine is cold

- 1 Open the fuel tap [1]
- 2 Switch on ignition (turn ignition key [2] into position  $\odot$ )
- 3 Swing up the side stand or center stand
- 4 Put the gear in neutral
- 5 Operate the choke [5]
- 6 Do not accelerate; operate starter button [3]

### ⚠ WARNING

- To avoid injuries, it is recommended to wear boots when using the kickstarter.
- Do not start the engine and allow it to idle in a closed area. Exhaust fumes are poisonous and can cause loss of consciousness and death. Always provide adequate ventilation while the engine is running.
- Always verify that the transmission has been set to idle (neutral) before actuating the starter button. If you start the motorcycle with a gear engaged, the motorcycle will move forward.

### ! CAUTION

- Maximal period for continuous starting: 5 seconds. Wait at least 5 seconds before trying again.
- Don't ride your motorcycle with full load and don't rev up the engine when cold because the piston is warming up faster than the water cooled cylinder and can cause engine damage.

#### NOTE:

The highly inflammable components in modern fuels volatilize if left standing for longer periods of time. If the motorcycle has not been used for over 1 week, the fuel should be drained from the float chamber. The engine will start up immediately if the float chamber is filled with fresh, ignitable fuel

## Starting when the engine is warm or hot

- 1 Open the fuel tap [1]
- 2 Switch on ignition (turn ignition key [2] into position  $\odot$ )
- 3 Swing up the side stand or center stand
- 4 Put the gear in neutral
- 5 Push the hot start button [4] (Keihin carburetors only)
- 6 Do not accelerate; operate starter button [3]

## What to do when the engine is "flooded"

In the event of a fall, more fuel than necessary may get into the engine. In order to "pump the engine free", pull the hand decompression lever, fully rev up the engine, actuate the kickstarter 5 to 10 times or actuate the E-starter 2 times for 5 seconds each. Then, start the engine as described above. If the engine fails to start, unscrew the spark plug and dry it.

#### NOTE:

The carburetor has an accelerator pump. Every time you open the throttle, fuel will be injected into the intake passage. When starting, be sure that you open the throttle completely only once.

## Kickstart instructions

Be sure to kick up the side stand before you start the engine to avoid any damage. Start as described above, then push the kickstarter hard all the way.

### ⚠ WARNING

- When starting the engine, make sure that you always wear sturdy motorcycling boots in order to avoid injury. You might slide off the kickstarter, or the engine may cause the kickstarter to recoil, thereby causing injuries to foot and leg.
- always kick the kickstarter briskly all the way and, while doing so, never open the throttle. Kickstarting with insufficient momentum and an opened throttle lever increases the danger of a possible recoil.

### ! CAUTION

- Before you start, check that the main or side stand has been swung up fully.

## Starting off

Turn on the light and pull the clutch lever. Put the engine into first gear, slowly release the clutch lever and open throttle at the same time.

### WARNING

Before you start, check that the main or side stand has been swung up fully. If the stand drags on the ground, the motorcycle can get out of control.

## Shifting/Riding

You are now in first gear, referred to as the drive or uphill gear. Depending on the conditions (traffic, hill size, etc.), you can shift to a higher gear. Close throttle, at the same time pull clutch lever in and shift to the next higher gear. Let clutch lever go again and open throttle. If you turned on the choke, make sure you turn it off again as soon as engine is warm.

When you reach full speed through opening the throttle all the way, turn throttle back to 3/4; the speed will not decrease but the engine will use less fuel.

Only give as much throttle as the engine can handle. Through quick and high revving of throttle, the fuel consumption increases. When shifting down, use the brakes if necessary and close throttle at the same time. Pull clutch lever and shift down to the next gear. Let clutch lever go slowly and open throttle or shift down again.

### NOTE:

Dedicated to nothing but offroad racing, 625 SXC models make no compromises in their design. As such, they do not include any radiator fan, and the size of the radiator is dimensioned for optimum ergonomics.

In normal racing, the cooling system is sufficient.

If you use your motorbike in other conditions, please note that: the E-starter allows you to start SXC/SMC Racing models again at any time. Therefore, turn off the engine if you intend to run your motorcycle in idle or at a standstill for longer periods of time (more than 2 minutes).

Avoid letting the clutch slip frequently and for extended periods. This would cause the engine oil to heat up, thereby heating up the cooling system. You should drive at low speeds (4-stroke style - letting the engine pull you) and not at high speeds not by letting the clutch slip (2-stroke style).

### WARNING

- Avoid abrupt load changes while riding around bends and on wet or slippery ground. Otherwise you might easily lose control of your motorcycle.
- Do not try to change the settings of the Tripmaster while driving. Your attention will be distracted from the traffic and may cause you to lose control of your motorcycle.
- When driving off-road, always have a friend on a second motorcycle to keep you company, so that you can help each other should difficulties arise.
- After falling with the motorcycle, check all functions thoroughly before starting up operations again.
- A bent handlebar must always be replaced. Never try to straighten the handlebar because this will cause it to lose its stability.

### CAUTION

- High rpm rates when the engine is cold have an adverse effect on the life of your engine. We recommend you run the engine in a moderate rpm range for a few miles to warm up. After that no further precautions in this respect need be taken. The engine has reached its operating temperature as soon as the radiators become warm.
- Never have the throttle wide open when changing down to a lower gear. The engine will over-rev, damaging the valves. In addition, the rear wheel locks so that the motorcycle can easily get out of control.

### CAUTION

- Long wheelies lead to a drop in the oil pressure which can lead to motor damage.
- If any abnormal vibrations occur while driving, check that the engine fastening bolts are tight.
- In the event that, while riding on your motorcycle, you notice any unusual operation-related noise, stop immediately, turn the engine off, and contact an authorized KTM dealer.

## Braking

Close throttle and apply the hand and foot brakes at the same time. Carefully apply the brakes on sandy, wet or slippery surfaces. Always brake with feeling, blocking wheels can cause you to skid or fall. Also change down to lower gears depending on your speed. Always finish braking before you enter a curve.

When driving down hill, use the braking effect of the engine. Change down one or two gears but do not overspeed the engine. In this way, you will not need to brake so much and the brakes will not overheat.

### WARNING

- When you brake, the brake discs, brake pads, brake caliper and brake fluid heat up. The hotter these parts get, the weaker the braking effect. In extreme cases, the entire braking system can fail.
- In case of rain, after washing the motorcycle, after rides through water and in case of rides on wet off-road tracks, humid or dirty brake discs can delay the braking effect. The brakes must be pulled until they are dry or clean.
- Rides on salt-strewn or dirty roads can also delay the braking effect. The brakes must be pulled until they are clean.
- Dirty brake discs cause increased tear of brake pads and brake discs.
- If the resistance in the hand brake lever or foot brake pedal feels “spongy” (too much play), this is an indication that something is wrong with the brake system. Don't ride your motorcycle anymore without first having the brake system looked over by a KTM dealer.

## Stopping and parking

Apply the brakes fully and put the engine into neutral. To stop the engine, switch off the ignition or pull the short circuit button when the engine is idling, until the engine stops. Turn the fuel tap to the OFF position, park on an area with firm ground, and lock the motorcycle.

### WARNING

- always park your motorbike on a solid and horizontal surface.
- Motorcycle engines produce a great amount of heat while running. The engine, exhaust pipe, muffler, brake rotors, and shock absorbers can become very hot. Do not touch any of these parts after operating the motorcycle, and take care to park it where pedestrians are not likely to touch it and get burned.

### CAUTION

- Always take out the ignition key when parking your motorcycle so that it cannot be used by unauthorized persons.
- Close the fuel tap when leaving your vehicle. Otherwise the carburettor can flood and fuel will enter the engine.
- Never park your motorcycle in fire hazardous places due to dry grass or other easily flammable materials.



## INFORMATION ABOUT THE SIDE STAND

Use your foot to push the side stand forward as far as possible, and lean your motorcycle to the side. Make sure that your motorcycle is standing safely on solid ground. Just in case, you can also put in a gear.

### ! CAUTION

The side stand is dimensioned for the weight of the motorcycle only. If you are sitting on the motorbike and thus apply an additional load onto the side stand, you may cause damage to the side stand or the frame, and your motorbike may fall over.

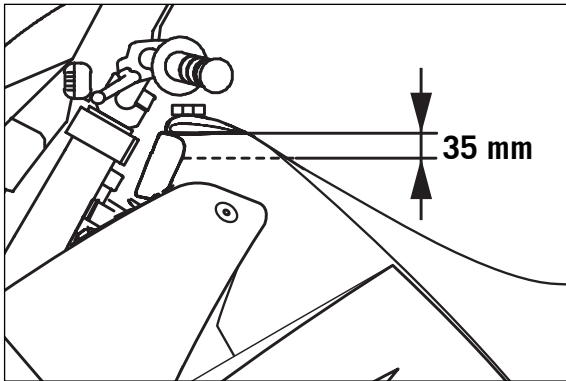

## Fuel

The LC4 engine needs premium gasoline with an octane number of 95 or higher.

625 SMC:

If using lower octane fuel, it is easy to change over to the pre-programmed ignition curve for 80 - 94 octane (ROZ) (see activating the ignition curve for low-octane fuel).

### ! CAUTION

Use leaded or unleaded premium grade gasoline (95 octanes). Never use any gasoline having less than 95 octanes because it may damage the engine.

### ⚠ WARNING

Gasoline is highly flammable and poisonous. Extreme caution should be used when handling gasoline. Do not refuel the motorcycle near open flames or burning cigarettes. Always switch off the engine before refuelling. Be careful not to spill gasoline on the engine or exhaust pipe while the engine is hot. Wipe up spills promptly. If gasoline is swallowed or splashed in the eyes, seek a doctor's advice immediately.

Fuel expands when its temperature rises. Therefore do not fill the tank to the top (see fig.).



# PERIODIC MAINTENANCE SCHEDULE »

<b>A WASHED MOTORCYCLE CAN BE CHECKED MORE QUICKLY WHICH SAVES MONEY!</b>		<b>1. Service after 1000 km or 10 hours</b>	<b>every 5000 km or once a year</b>
<b>ENGINE</b>	Change engine oil, oil filter, and fine filter	●	●
	Clean oil screens and magnet of drain plug	●	●
	Check oil lines for damage and kink-less arrangement	●	●
	Check and adjust spark plug, replace every 10,000 km		●
	Check and adjust valve clearance	●	●
	Check engine fastening screws for tight fit	●	●
	Make sure all engine screws accessible from the outside are screwed tight	●	●
<b>CARBURATOR</b>	Check carburetor connection boots for cracks and leaks		●
	Check idle setting	●	●
	Check bleeder hoses for damage and kink-free arrangement	●	●
<b>ADD-ON-PARTS</b>	Check cooling system for leaks, antifreeze protection	●	●
	Check radiator fan for proper function		●
	Check exhaust system for leaks and suspension	●	●
	Check actuating cables for damage, smooth operation, and kink-less arrangement, adjust and lubricate	●	●
	Check fluid level of the clutch master cylinder		●
	Clean air filter and air filter box		●
	Check cables for damage and kink-less arrangement		●
	Check headlamp adjustment		●
	Check electrical system for function; (low/high beams, stop light, turn indicators, tell-tale lamps, horn, emergency-off switch)	●	●
	Make sure all screws and nuts are tight	●	●
<b>BRAKES</b>	Check brake fluid level, lining thickness, and brake discs	●	●
	Check brake lines for damage and leaks	●	●
	Check/adjust smooth operation, free travel of handbrake/footbrake levers	●	●
	Check screws of brake system for tight fit	●	●
<b>CHASSIS</b>	Check suspension strut and fork for leaks and proper function	●	●
	Check O-ring of suspension strut for wear		●
	Clean dust sleeves		●
	Bleed fork legs	●	●
	Check swinging-fork pivot		●
	Check/adjust steering-head bearing	●	●
	Lubricate reversing lever		●
<b>WHEELS</b>	Check all chassis screws for tight fit (fork plates, fork leg, axle nuts/screws, swinging-fork pivot, reversing lever, suspension strut)	●	●
	Check spoke tension and rim join	●	●
	Check tire condition and inflation pressure	●	●
	Check chain and chain guides for wear, force fit and tension	●	●
	Check screws on pinion and chain sprocket for locking devices and a tight fit	●	●
	Clean chain (Motorex 611), lubricate	●	●
Check wheel bearings and jerk damper for play		●	

# PERIODIC MAINTENANCE SCHEDULE »

IMPORTANT SERVICE WORK THAT MUST BE PERFORMED BY AN AUTHORIZED KTM WORKSHOP UNDER A SEPARATE ORDER			
	every 2500 km or 25 hours	at least once a year	every 2 years or 20000 km
Perform complete fork maintenance		●	
Perform complete suspension strut maintenance			●
Perform complete reversing lever maintenance			●
Replace glass-fiber yarn packing of main silencer	●		
Clean and lubricate steering-head bearing and sealing elements		●	
Clean and adjust the carburetor		●	
Treat the electrical contacts and switches with contact spray		●	
Change brake fluid		●	

VITAL CHECKS AND CARE PROCEDURES TO BE CONDUCTED BY THE OWNER OR THE MECHANIC				
	before each start	after every cleaning	for cross country use	once a year
Check oil level	●			
Check brake fluid level	●			
Check brake pads for wear	●			
Check lighting system for proper operation	●			
Check horn for proper operation	●			
Lubricate and adjust actuating cables and nipples		●		
Bleed fork legs in regular intervals			●	
Remove and clean dust sleeves in regular intervals			●	
Clean and lubricate chain as necessary		●	●	
Check chain tension	●	●	●	
Clean air filter and filter box (depending on the dirt accumulation)			●	
Check tire pressure and wear	●			
Check coolant level	●			
Check fuel lines for leaks	●			
Drain float chamber		●		
Verify smooth operation of all controls	●			
Check brake performance	●	●		
Treat exposed metal components (except for the braking and exhaust systems) with wax-based anti-corrosion agents		●		
Treat steering lock and light switch with contact spray		●		
Check all screws, nuts, and hose clamps for tight fit				●

## **⚠ WARNING**

All maintenance and adjustment operations that are marked with a \* require specialist knowledge. For your own security, let these tasks be carried out by a ktm-dealer. At ktm your motorcycle will receive optimal servicing by specially trained mechanics.

## **! CAUTION**

- When cleaning the motorcycle, do not use a high pressure cleaning unit if possible, otherwise water will penetrate the bearings, carburetor, electric connectors etc.
- When transporting your KTM, ensure that it is held upright with restraining straps or other mechanical fastening devices and that the fuel tap is in the OFF position - if the motorcycle should fall down, be aware of any leaking fuel from the carburetor or fuel tank
- Do not use toothed washers or spring rings with the engine fastening screws, as these work into the frame parts and keep working loose. Instead, use self-locking nuts.
- Let your motorcycle cool down before beginning any maintenance work in order to avoid getting burned.
- Remove Oils, fatty matters, filters, fuels, washing detergents etc. orderly.
- Under no circumstances may used oil be disposed of in the sewage system or in the open countryside. 1 liter used oil contaminates 1.000.000 liters water.
- if you unfasten self-locking nuts, you have to replace them by new ones.
- if you unfasten screws and nuts secured by loctite, you have to reattach and secure them in the same way. See technical specifications - fastening torques.

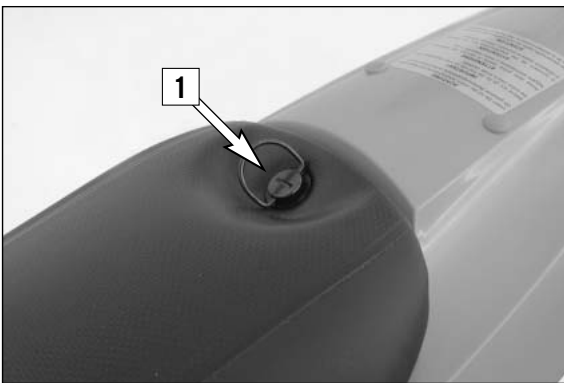

### **Removal of seat (SXC)**

By using the quick-release fastener [1], the seat can be removed without using tools. Turn the quick-release fastener about 180° counter clockwise and lift up the rear of the seat. Pull the seat backwards and unhook it from the front fastener screw [2].

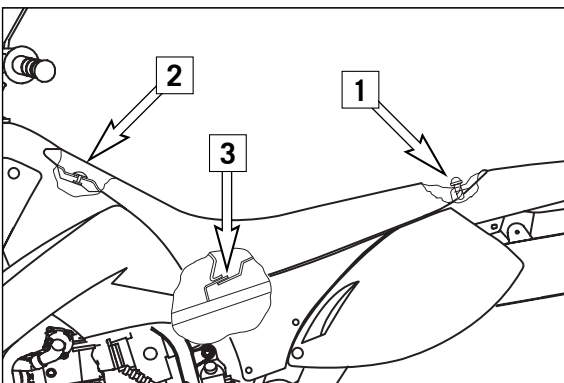

When installing the seat, be sure to insert the rear portion of the seat into the metal clasp [3].

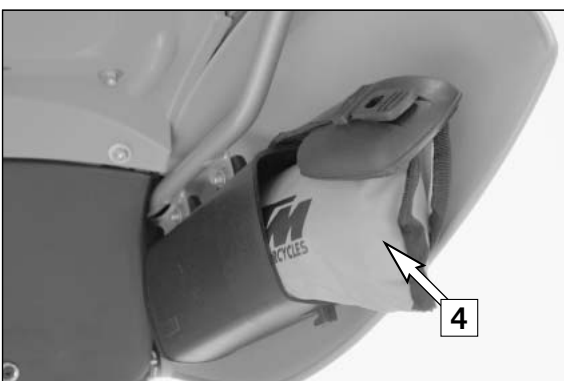

### **Tool set (SXC)**

The tool set [4] is located in the tool box under the right side cover.



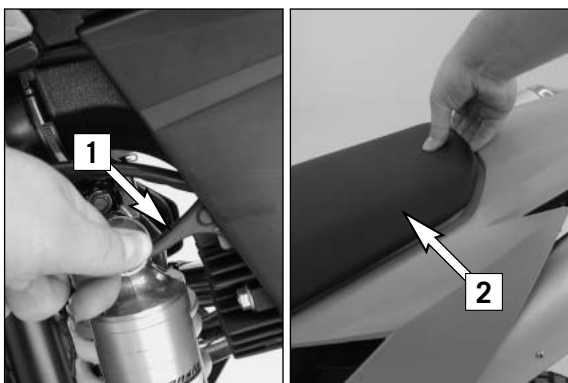

## Removal of seat (SMC)

Actuate the lever [1] while lifting the back of the seat [2].

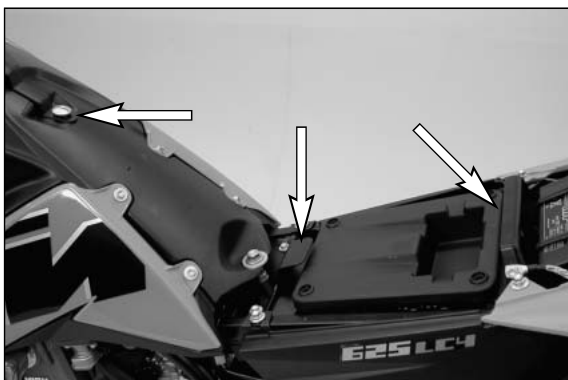

When you mount the seat, make sure the retaining brackets are fastened to the seat.

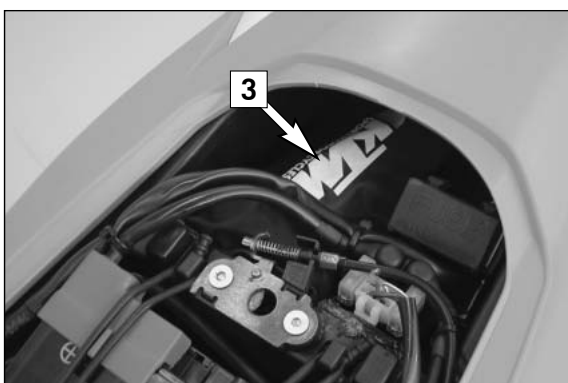

## Tool set (SMC)

The tool set [3] is located under the seat.

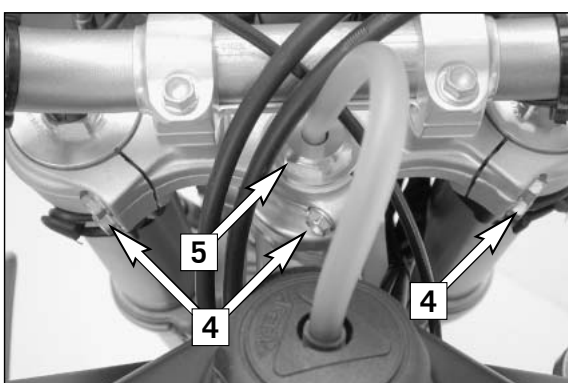

## Check and adjust steering head bearing \*

Check steering head bearing for play periodically. To check this put motorcycle on a stand so that the front wheel is off the ground. Now try to move the fork forward and backward. To adjust, loosen the five pinch bolts [4] of the top triple clamp and turn steering stem bolt [5] clockwise until there is no more play. Don't tighten the steering stem bolt all the way, otherwise the bearings will be damaged. With a plastic hammer, lightly tap on the triple clamp to release tension. Retight the five pinch bolts with 20 Nm (15 ft.lbs).

### ⚠ WARNING

If the steering head bearing is not adjusted to be free of play, the motorcycle will show an unsteady driving performance and can get out of control.

### ! CAUTION

If you drive with play of steering head bearing for longer periods, first the bearings and then the bearing seats in the frame will be destroyed.

At least once a year, the steering head bearings should be smeared with water-proof grease (Motorex Long Term 2000).

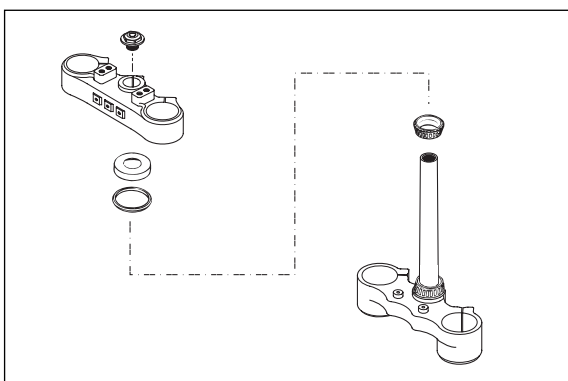

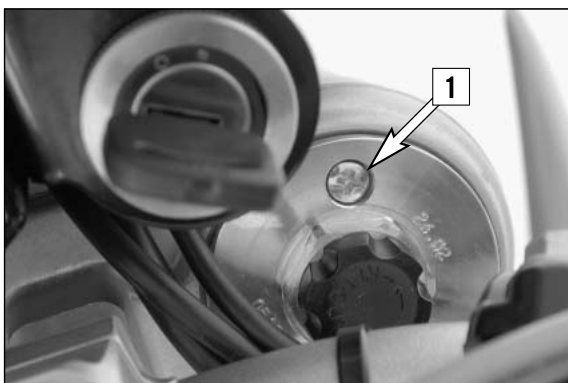

## Breather plug front fork

After every 5 hours of use for competitive racing, slacken the breather plugs [1] a few turns in order to relieve excess pressure from the inside of the fork. To do this, place the motorcycle on a stand with the front wheel lifted off the ground. When riding the motorcycle mainly on street, it will be enough to have this job performed in the course of the periodical maintenance service.

### ! CAUTION

Excessive pressure in the interior of the fork can cause leaks in the fork. If your fork is leaking, it is recommended to open the breather plugs before having the seals replaced.

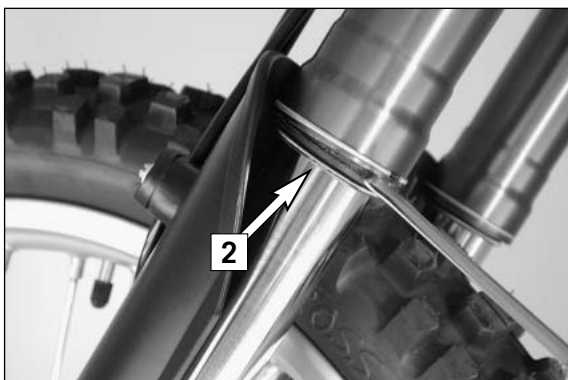

## Cleaning the dust sleeves of the telescopic fork

The dust-protection bellows [2] are to remove dust and coarse dirt particles from the fork tube. However, after some time, dirt may also get in behind the dust-protection bellows. If this dirt is not removed, the oil sealing rings located behind it may start to leak.

Use a screwdriver to lever the dust-protection bellows out of the outer tubes and slide them downward.



Clean dust-protection bellows, outer tubes, and fork tubes thoroughly, and oil them thoroughly with silicone spray. Then, push dust-protection bellows into the outer tubes by hand.

### ! CAUTION

No silicone oil may reach the front tire or the brake disks since this would considerably reduce the tire's road grip and the braking effect of the front brake.



## How to change the handlebar position

The handlebar position can be readjusted by 22 mm. Thus, you can put the handlebar to the position that is the most convenient for you. The upper triple clamp [3] includes 2 bores arranged at a distance of 15 mm (0,6 in) from one another. The bores at the handlebar support [4] are offset from the center by 3.5 mm (0.13 in). Accordingly, you can mount the handlebar in 4 different positions.

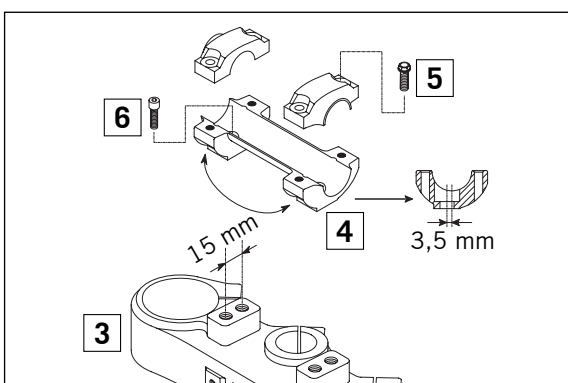

For this purpose, remove screws [5] of the handlebar clamps and screws [6] of the handlebar support. Position handlebar support, and tighten screws [6] to 40 Nm (30 ft.lbs). Mount handlebar and handlebar clamps, and tighten screws [5] to 20 Nm (15 ft.lbs). The gap between handlebar support and handlebar clamps is to be of equal size in the front and in the rear.

### ! WARNING

The screws [6] must be secured with Loctite 243.

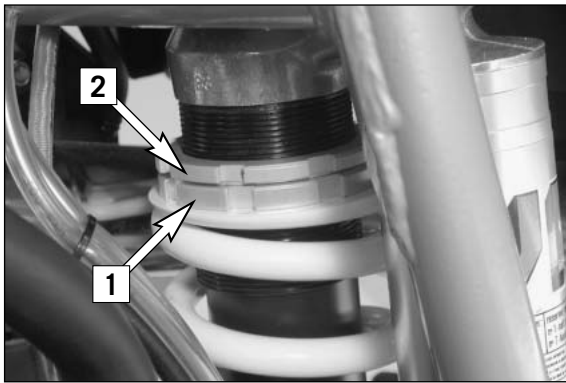

## Changing the spring preloading of the shock absorber

KTM sets the shock absorber for a driver with a weight of approximately 75 kg (165 lb). If the weight of the driver is more or less than 75 kg (165 lb), you should change the spring preloading A accordingly. This is easily done.

NOTE:

- Before changing the spring preload note the basic setting, e.g. how many threads are visible above the adjusting ring.
- One rotation of the adjusting ring [1] changes the spring pretension by approximately 1.75 mm (0.07 in).

Loosen the locking ring [2] with the hook spanner from the tool set. Change the spring preload with the adjusting ring [1] and re-tighten the locking ring.

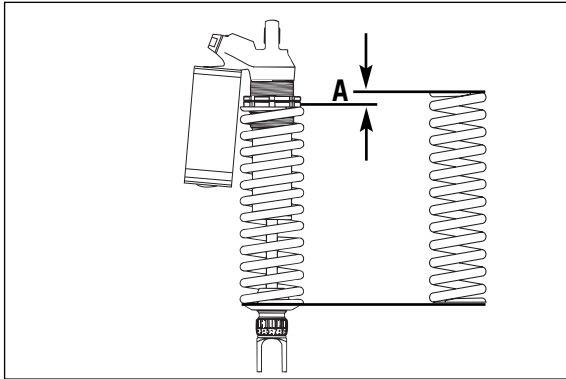

BASIC SETTING – SPRING PRELOAD:

WP 01187B01 ..... A = 23 mm

WP 01187B02 ..... A = 20 mm

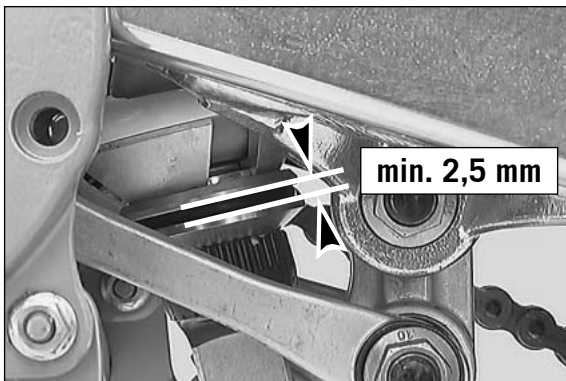

## Checking rubber ring on the WP rear shock absorber

A rubber ring mounted on the rear shock absorber serves as a vibration damper. This ring gets pressed together with time and loses its shock absorbing function.

Measure the distance between the two discs at various points around their circumferences. The space should be at least 2.5 mm (0.1 in) wide. Have the rubber ring replaced by an KTM dealer when compaction due to wear has exceeded this lower limit.

### ! CAUTION

Not replacing the rubber ring in time can result in damage to the rear shock absorber.

### ⚠ WARNING

The damping unit of the shock absorber is filled with high compressed nitrogen. Never try to take the shock absorber apart or to do any maintenance work yourself. Severe injuries could be the result.

## Lubricate rear suspension linkage

The bearings in the link lever must be greased in regular intervals. For this purpose, a lubricating nipple [3] is mounted on the link lever.

### ! CAUTION

After each time the motorcycle is washed, it is especially important to grease the lubricating nipple to push any water out of the bearings.

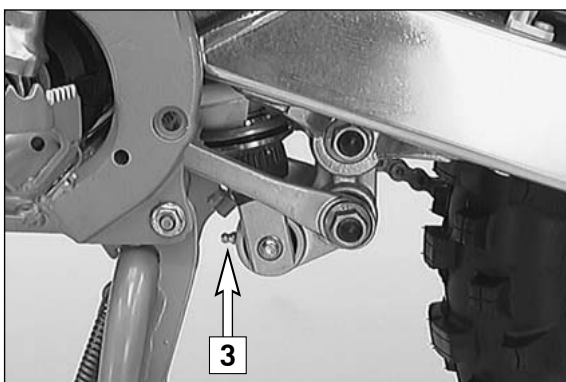

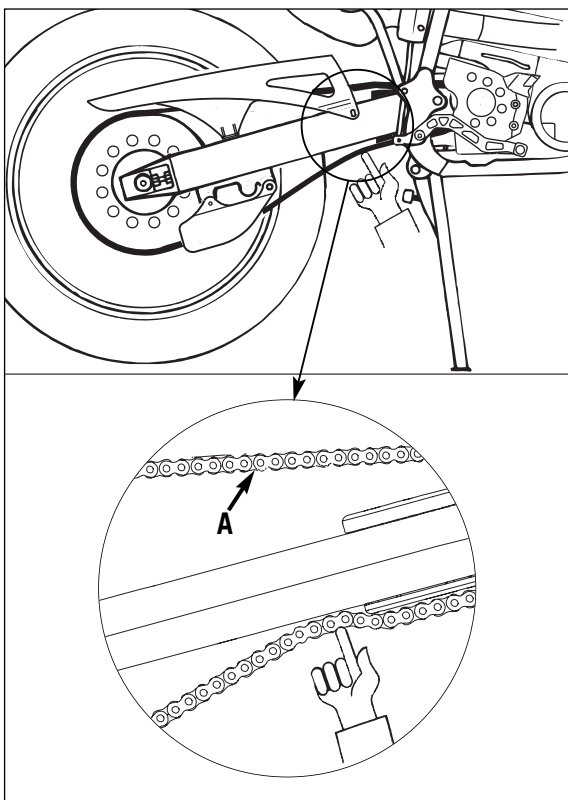

## Checking chain tension

To check, jack up the motorcycle on the center stand or frame until it no longer touches the ground. Press the chain up approx. 30 mm behind the end of the chain sliding component. The chain should barely touch the swing arm when the upper chain part [A] is tensioned. If not, correct the chain tension.

### ⚠ WARNING

- If chain tension is too high, parts within the secondary transmission (chain, sprockets, drive assembly and rear wheel bearings) will be subjected to unnecessary stress, resulting in premature wear and even chain breakage.
- Too much slack in the chain, on the other hand, can result in the chain jumping off the sprockets. If this happens, the chain could also block the rear wheel or damage the engine.
- In either case the operator is likely to lose control of the motorcycle.

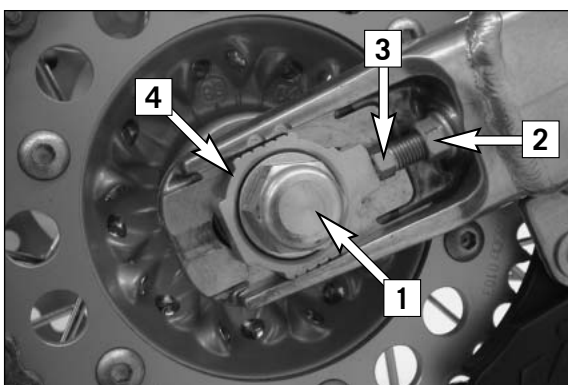

## Correct chain tension

Loosen collar nut [1], loosen lock nuts [2], and turn right and left adjusting screws [3] equally far. Tighten lock nuts [2].

Before tightening the collar nut, verify that the chain adjusters [4] are sitting close to the adjusting screws and that the rear wheel has been aligned with the front wheel.

Tighten collar nut [1] with 80 Nm (59 ft.lb).

### ⚠ WARNING

If you don't happen to have a torque wrench at hand, make sure you have the tightening torque corrected by a KTM dealer as soon as possible. A loose axle may lead to an unstable driving behavior of your motorcycle.

#### NOTE:

The large adjusting range of the chain adjusters (32mm) allows you to use different secondary ratios in combination with the same chain length. The chain adjusters [4] can be rotated by 180°.

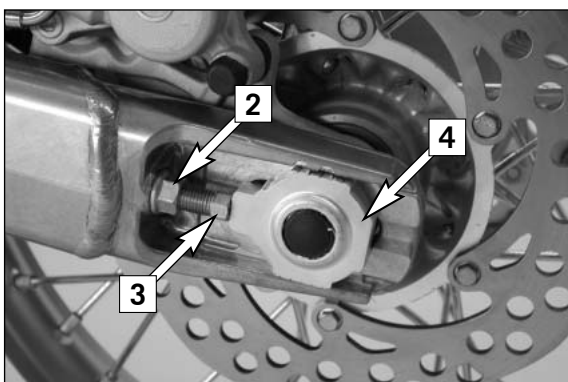



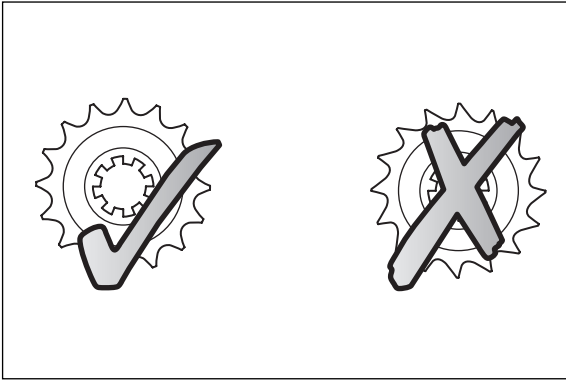

## Chain maintenance

For long chain life, good maintenance is very important. X-ring chains require only modest maintenance. The best way is to use lots of water, but never use brushes or solvents. After letting the chain dry, you can use a special X-ring chain spray (Motorex Chainlube 622).

### ⚠ WARNING

No lubrication is allowed to reach the rear tire or the brake disk, otherwise the road adherence and the rear wheel braking effects would be strongly reduced and the motorcycle could easily get out of control.

### ! CAUTION

- The chain does not have a chain joint for safety reasons. Always have the chain replaced in an authorized KTM workshop where the service technicians have the required riveting tool.
- Never mount a normal chain joint.

Also check sprockets and chain guides for wear, and replace if necessary.

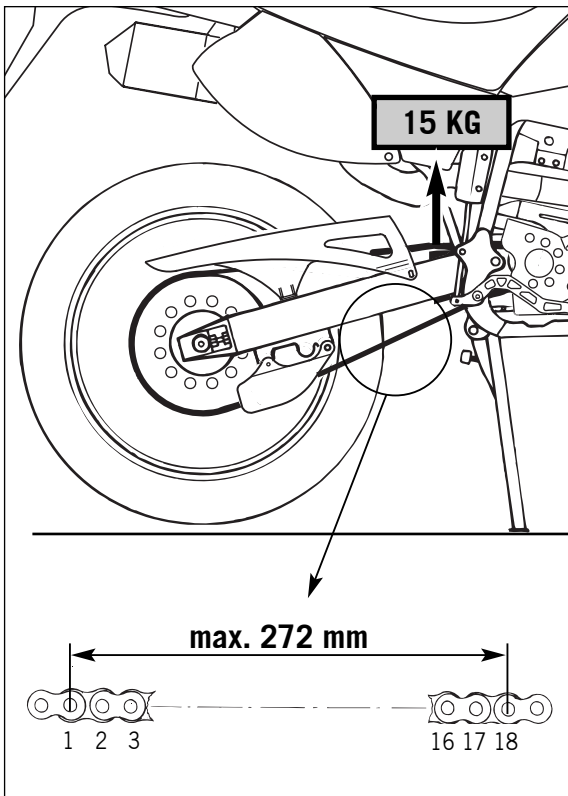

## Chain wear

In order to check the chain wear, regard the following indications: Shift the gear into idling and pull the upper chain strand with approx. 10-15 kilogram (33 lb) upwards (see figure). Now one can measure a space of 18 chain reels at the lower chain strand. The chain should be replaced at the latest when a space of 272 mm (10.70 in) is measured. Chains do not always wear off evenly, therefore repeat the measurement at different places on the chain.

### NOTE:

If you mount a new chain, the sprockets should also be replaced. New chains wear faster if used on old used sprockets

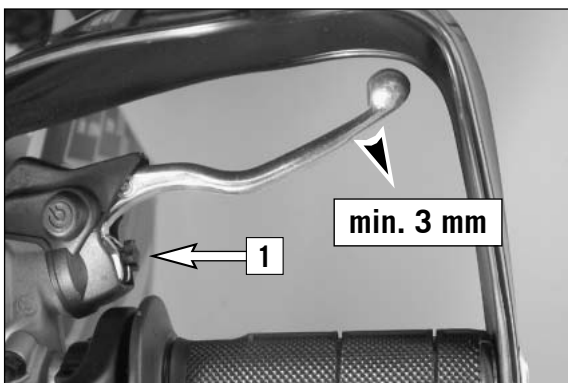

## Adjusting of free travel at the hand brake lever (SXC)

Free travel at the hand brake lever may be readjusted by using adjustment screw [1]. In this way, the position of the point of pressure (i.e., the resistance you feel on the hand brake lever when the brake pads are pressed against the brake disc) can be adjusted for any hand size.

### ! CAUTION

At the hand brake lever, free travel must at least be 3 mm. Only then may the piston in the hand brake cylinder be moved (to be recognized by the greater resistance of the hand brake lever). If this free travel is not provided, pressure will build up in the braking system, and the front wheel brake may fail due to overheating.

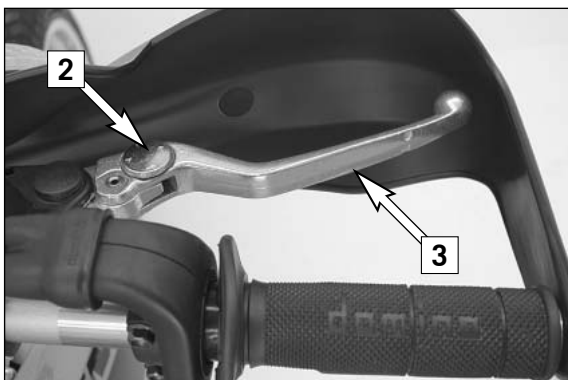

## Changing the basic position of the handbrake lever (SMC)

The adjusting screw [2] allows you to change the basic position of the handbrake lever [3].

Press the handbrake lever's outer end forward, and, at the same time, turn the adjusting screw.

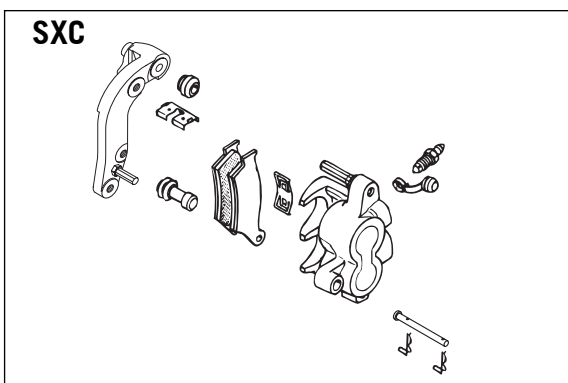

## General information about KTM disc brakes

### BRAKE CALIPERS (SXC):

The brake calipers of this series "float". This means that the brake calipers are not solidly attached to the caliper support. Thus, the brake pads are always in optimum contact with the brake disc. Secure the screws of the caliper support with Loctite 243 and tighten to 25 Nm (19 ft.lb).

### BRAKE CALIPERS (SMC):

The front brake caliper [4] has 4 brake pistons and is rigidly connected to the fork leg. The rear brake caliper has one brake piston and "floats", which means that it is not rigidly connected to the brake caliper support. The resulting lateral adjustment ensures that the brake pads [5] optimally rest against the brake disk at any time. Secure the screws [6] of the caliper support with Loctite 243 and tighten to 40 Nm.

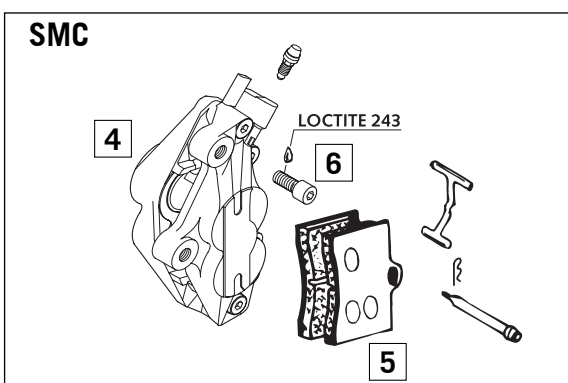

### BRAKE PADS (SXC):

The brake pads are fitted with TOSHIBA TT 2701 sintered lining at the front and ID450 organic lining at the back.

### BRAKE PADS (SMC):

The brake pads are fitted with ID450 organic lining

These linings provide an optimal combination of dosing, brake performance and life cycle. The lining type is stated on the back of the brake pad and also recorded in the homologation papers.

Other brake pads are available for competition sports.

### ! WARNING

Brake shoes available in the accessory trade are often not authorized for operation of your KTM motorcycle in road traffic. The brake shoe's design and friction factor and therefore the braking power can deviate significantly from original KTM brake shoes. If you use different brake shoes than those provided with the original equipment, it cannot be warranted that they are authorized for use in road traffic. Your motorcycle will not longer comply with the regulations authorizing the use of vehicles for road traffic and the warranty will be void.

### BRAKE FLUID RESERVOIRS:

The brake fluid reservoirs on the front and rear wheel brakes have been designed in such a way that even if the brake pads are worn it is not necessary to top up the brake fluid. If the brake fluid level drops below the minimum either the brake system has a leak or the brake pads are completely worn down. In this case, consult an authorized KTM dealer immediately.



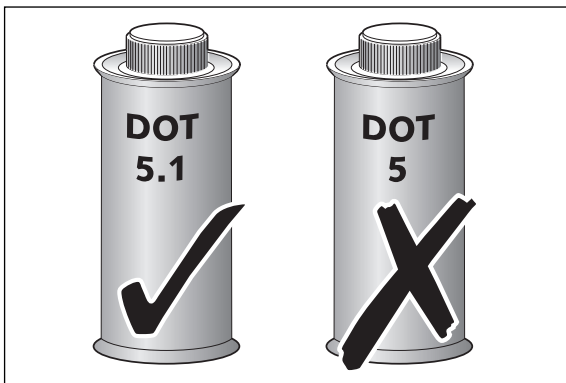

## BRAKE FLUID:

We recommend that you use Motorex DOT 5.1 brake fluid when you refill or change the brake fluid. DOT 5.1 brake fluid has a wet boiling point of 180°C (25°C higher than DOT 4) and is safer for high performance applications. Brake fluid DOT 5.1 is a polyethylene glycol based fluid, amber-colored and can be mixed with DOT 4 brake fluid.

Never use DOT 5 braking fluid. It is based on silicone oil and has a purple color. Gaskets and brake hoses are not compatible with it.

### ⚠ WARNING

Have the brake fluid changed at least once annually. If you wash your motorcycle often, the brake fluid should be changed even more frequently. Brake fluid tends to absorb water. Therefore, vapor pockets may form in "old" brake fluids even at low temperatures, causing the brake system to fail.

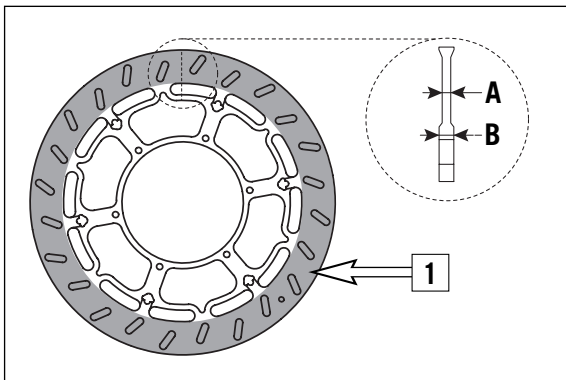

## BRAKE DISCS:

Wear reduces the thickness of the brake disc in the area of contact [1] with the brake pads. At its thinnest spot [A], the brake disc must not be more than 0.4mm thinner than its nominal dimension [B]. The nominal dimension can be gaged in a location beyond the area of contact with the brake pads. Check wear in several spots.

### ⚠ WARNING

- Brake discs suffering from wear greater than 0.4 mm constitute a safety hazard. Have the brake disc replaced immediately as soon as it reaches its wear limit.
- As a matter of principle, have any repair of the brake system carried out by a licensed KTM mechanic.

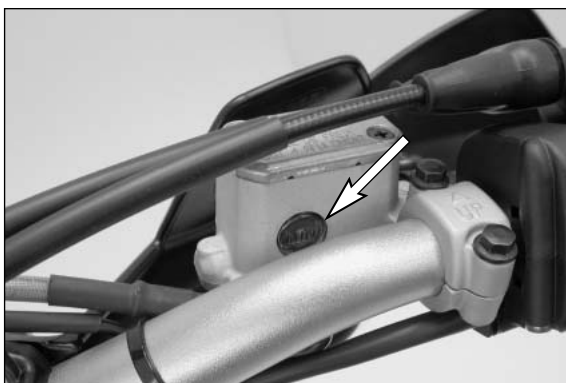

## Checking of brake fluid level - front brake

The brake fluid reservoir is linked with the hand brake cylinder at the handlebar and the reservoir is provided with an inspection glass. With the reservoir in a horizontal position, the brake fluid level should not drop below the middle of the glass. The reservoir should be kept completely full at all times for best performance.

### ⚠ WARNING

If the brake fluid level drops below the minimum either the brake system has a leak or the brake pads are completely worn. In this case, consult an authorized KTM dealer immediately.

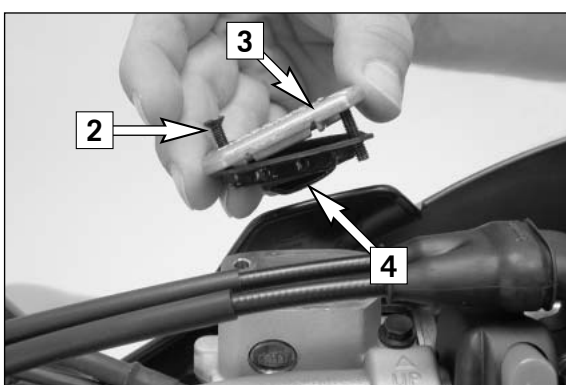

## Refilling the front brake fluid reservoir \*

When the brake fluid falls to the middle of the inspection glass, new brake fluid has to be added.

Loosen screws [2] and remove lid [3] and membrane [4].

Place hand brake cylinder in a horizontal position and fill the brake fluid reservoir to 5 mm (0,2 in) below the rim with clean brake fluid DOT 5.1 (Motorex Brake Fluid DOT 5.1). Replace membrane and lid, tighten screws. Rinse off spilled or overflowing brake fluid with water.

### ⚠ WARNING

- Never use DOT5 brake fluid! It is based on silicone oil and of a purple color. Seals and brake hoses must be especially adapted to it.
- Store brake fluid out of reach of children.
- Brake fluid can cause skin irritation. Avoid contact with skin and eyes. If you get brake fluid in your eyes, rinse with plenty of water and consult a doctor.

### ! CAUTION

- Don't let brake fluid get in contact with paint, it is an effective paint remover.
- Use only clean brake fluid taken from a tightly sealed container.

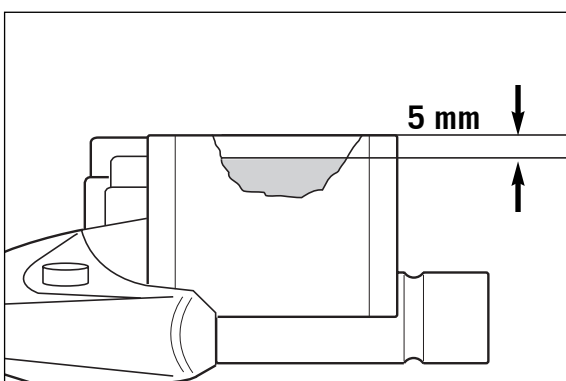

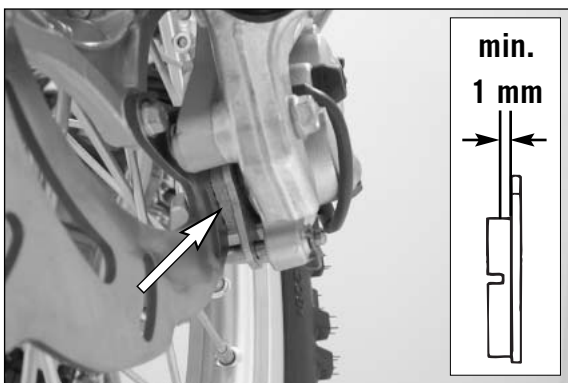

## Checking the front brake pads (SXC)

The brake pads can be inspected from below. The linings must be at least 1 mm (0,04 in) thick.

### ⚠ WARNING

At their most worn point brake pad linings should not be thinner than 1 mm, otherwise they could lead to brake failure. For your own safety don't put off having your brake pads changed.

### ! CAUTION

If the brake pads are replaced too late so that the lining is partly or entirely worn, the steel components of the brake pad will rub against the brake disc, thereby impairing the braking effect and destroying the brake disc.

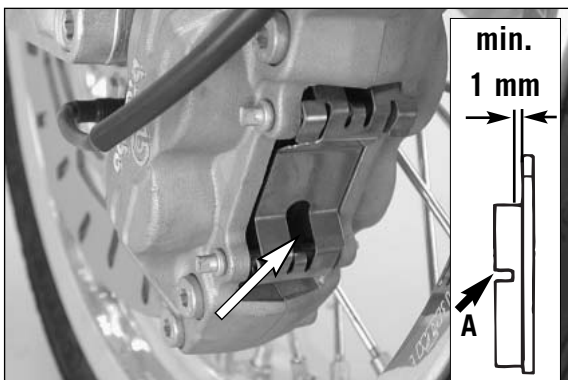

## Checking the front brake pads (SMC)

The brake pads can be inspected from behind. Always inspect the brake pad linings before taking off on your motorcycle. They should not be thinner than 1 mm which is the case when the notch [A] is no longer discernable.

### ⚠ WARNING

At their most worn point brake pad linings should not be thinner than 1 mm, otherwise they could lead to brake failure. For your own safety don't put off having your brake pads changed.

### ! CAUTION

If the brake pads are replaced too late so that the lining is partly or entirely worn, the steel components of the brake pad will rub against the brake disc, thereby impairing the braking effect and destroying the brake disc.

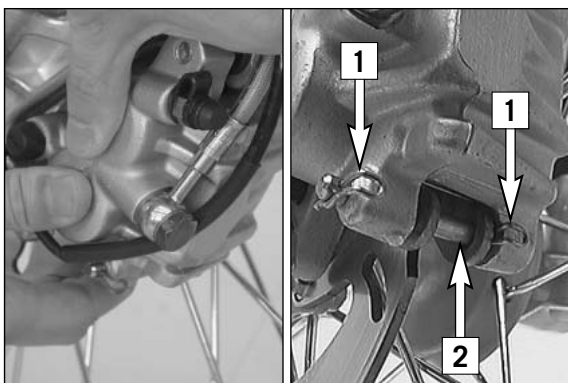

## Replacing front brake pads (SXC) \*

Press the brake caliper toward the brake disk, to put the brake piston in its basic position. Remove clips [1] and pull out bolt [2]. Remove brake pads from the brake caliper. Clean the brake caliper and the brake caliper support with compressed air. Check the sleeves of the guide bolts for damage, and grease guide bolts if necessary.

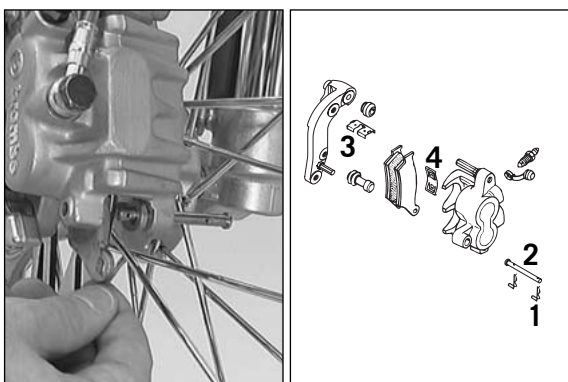

Mount the right brake pad and fix it with the bolt. Mount the left brake pad and insert the bolt until it stops. Mount the clips.

When mounting the brake pads, be sure to check for correct fit of the sliding metal-sheet [3] in the caliper support and of the leaf spring [4].

### ⚠ WARNING

- It is very important to keep the brake disk free from oil and fatty matters. Otherwise, the braking effect would be strongly reduced.
- After assembly, check if circlips have been fitted correctly.
- Having performed any work on the braking system, one must always actuate the hand brake lever or foot brake lever, respectively so as to ensure that the brake pads will lie against the brake disk and the pressure point is established.



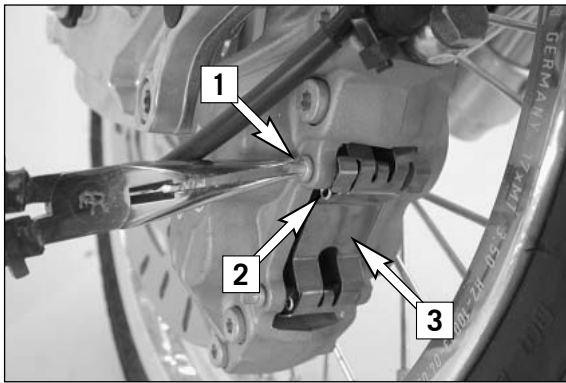

## Replacing the front brake pads (SMC) \*

Turn the upper bolt [1] approx. 45° in a clockwise direction with a wrench until you see the stopper [2]. Remove the stopper on both bolts, pull out the bolts and demount the retaining spring [3].

Carefully press against the brake pads with a screwdriver to move the brake pistons into the basic position. Remove brake pads from the brake caliper and clean the brake caliper thoroughly with compressed air.

Slide new brake pads in the brake caliper and mount a bolt [4] to help find the right position. The bolt must fit through the [A] holes in the brake pads (see illustration).

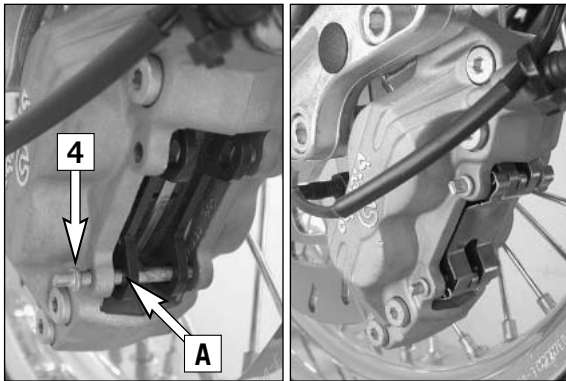

Remove the bolt, position the retaining spring (be careful not to move the brake pads) and mount both bolts. Mount the stoppers and turn the upper bolt approx. 45° in a counter-clockwise direction until the stopper is under the retaining spring.

### ⚠ WARNING

- It is very important to keep the brake disk free from oil and fatty matters. Otherwise, the braking effect would be strongly reduced.
- After assembly, check if circlips have been fitted correctly.
- Having performed any work on the braking system, one must always actuate the hand brake lever or foot brake lever, respectively so as to ensure that the brake pads will lie against the brake disk and the pressure point is established.

## Check the rear brake fluid level

The reservoir for the rear disc brake is located above the main brake cylinder. The level of brake fluid may not fall below the „MIN“ mark when the vehicle has been left standing upright

### ⚠ WARNING

If the brake fluid level drops below the minimum either the brake system has a leak or the brake pads are completely worn. In this case, consult an authorized KTM dealer immediately.



## Refilling the rear brake fluid reservoir \*

When the brake fluid level has dropped to the MIN mark, you need to refill the brake fluid reservoir.

For easier access to the brake fluid reservoir it is recommended to remove the hexagon screw [5]. Then move the container outwards as indicated in the illustration. Remove plug [6] with rubber boot [7] and add brake fluid DOT 5.1 (Motorex Brake Fluid DOT 5.1) up to the „MAX“ mark. Replace rubber boot and plug. Overflow or spilled brake liquid must be rinsed off with water. Mount the screw and fix the brake fluid reservoir to the frame, always making sure to prevent kinks in the connecting hose.



### ⚠ WARNING

- Never use DOT5 brake fluid! It is based on silicone oil and of a purple color. Seals and brake hoses must be especially adapted to it.
- Store brake fluid out of reach of children.
- Brake fluid can cause skin irritation. Avoid contact with skin and eyes. If you get brake fluid in your eyes, rinse with plenty of water and consult a doctor.

### ! CAUTION

- Don't let brake fluid get in contact with paint, it is an effective paint remover.
- Use only clean brake fluid taken from a tightly sealed container.



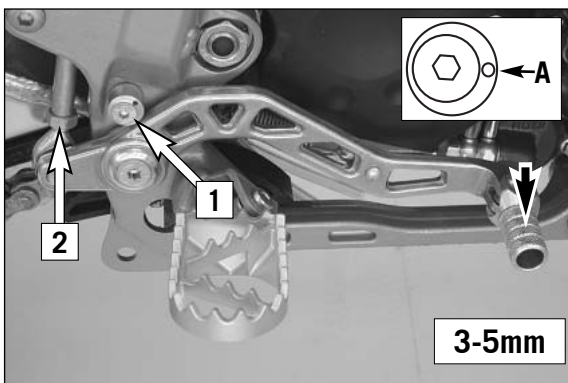

## Changing the basic position of the brake pedal \*

The basic setting of the foot brake pedal can be changed by turning the end stop roller [1]. Using the push rod [2], the free play on the foot brake pedal must be set.

Measured on the outside, the foot brake pedal must have 3-5 mm of free play, before the push rod can move the piston in the brake cylinder (to be recognised from the resistance on the foot brake pedal).

To keep the stop roller from turning while tightening, insert a hexagon wrench in bore [A].

### ! CAUTION

If this clearance is missing, pressure accumulates in the braking system and the brake pads begin to rub. The braking system overheats and can fail completely in extreme cases.

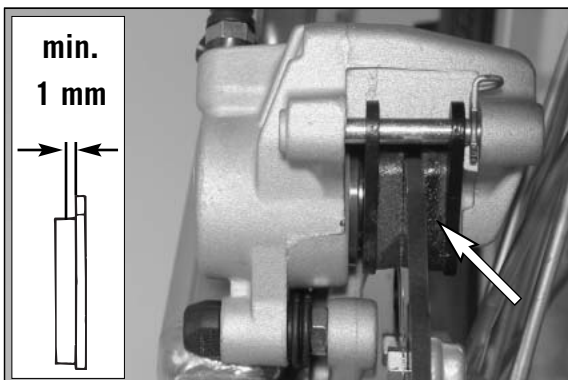

## Checking the rear brake pads

The brake pads can be inspected from the rear. The thickness of the linings may not be less than 1 mm (0.04 in).

### ⚠ WARNING

At their most worn point brake pad linings should not be thinner than 1 mm, otherwise they could lead to brake failure. For your own safety don't put off having your brake pads changed.

### ! CAUTION

If the brake pads are replaced too late so that the lining is partly or entirely worn, the steel components of the brake pad will rub against the brake disc, thereby impairing the braking effect and destroying the brake disc.

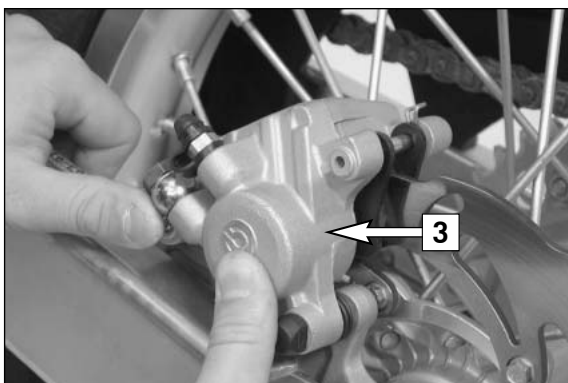

## Replacing the rear brake pads \*

Press brake caliper [3] in direction of chain wheel for the brake piston to reach its basic position. Remove safety device [4], knock out the guide pin [5] from the brake caliper with a drift towards the chain wheel and remove brake pads. Carefully clean the brake caliper with compressed air and check sleeves of the guide pins for damage.

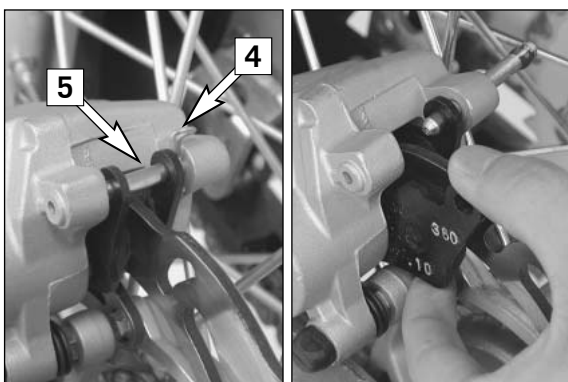

Slide left brake pad into the brake caliper and fix it with the pin. Slide in the right brake pad and knock the bolt in as far as it will go. Mount safety device [4].

### ⚠ WARNING

- It is very important to keep the brake disk free from oil and fatty matters. Otherwise, the braking effect would be strongly reduced.
- After assembly, check if circlips have been fitted correctly.
- Having performed any work on the braking system, one must always actuate the hand brake lever or foot brake lever, respectively so as to ensure that the brake pads will lie against the brake disk and the pressure point is established.

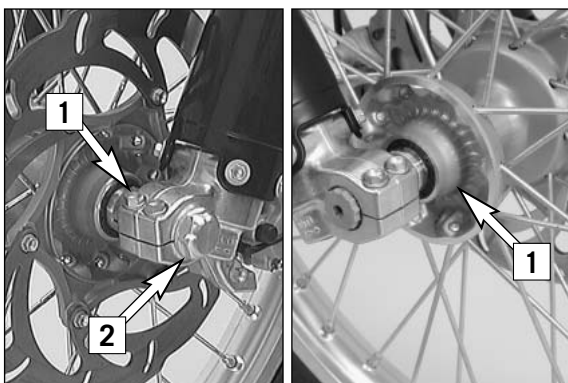

## Dismounting and mounting the front wheel (SXC)

To remove the front wheel, jack the motorcycle up on its frame so that the front wheel no longer touches the ground.

Loosen both clamp screws [1] on the left fork leg. Then loosen the collar nuts [2] before loosening the clamp screws [1] on the right fork leg.

Hold the front wheel and withdraw the wheel spindle [3].

### ! CAUTION

- Do not operate the hand brake when the front wheel has been dismounted.
- Always place the wheel on the ground with the brake disc pointing upwards. Otherwise the brake disc may be damaged.

To install the front wheel, lift it into the fork, position and mount the axle shaft. Mount the collar nut [2], tighten the clamping screws [1] on the right fork leg axle passage to prevent the axle shaft from turning and tighten the collar nut to 40 Nm (30ft.lb). Loosen the clamp screws on the right fork leg. Take the motorcycle down from its stand. Press the front wheel brakes and push down on the fork a few times vigorously so that the fork legs come into alignment. Only after this has been accomplished, tighten the clamp screws on both fork legs with 15 Nm

### ⚠ WARNING

- If you don't happen to have a torque wrench at hand, make sure you have the tightening torque corrected by a KTM dealer as soon as possible. A loose axle may lead to an unstable driving behavior of your motorcycle.
- After mounting the front wheel, keep operating the hand brake until the pressure point returns.
- It is very important to keep the brake disc free from oil and fatty matters, otherwise the braking effects would be strongly reduced.

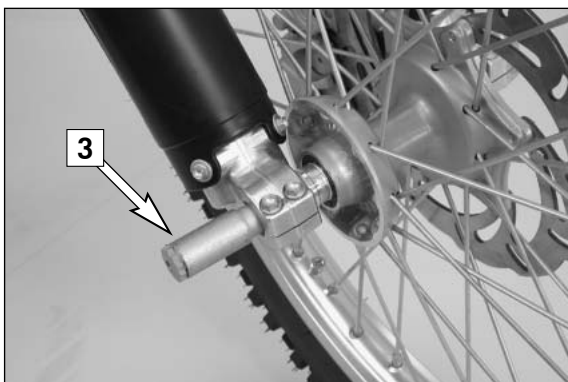

## Dismounting and mounting the front wheel (SMC)

To remove the front wheel, jack the motorcycle up on its frame so that the front wheel no longer touches the ground.

To remove the front brake caliper, remove both screws [4] and pull the caliper backwards from the brake disc.

Loosen both clamp screws [5] on the left fork leg.

Then loosen the collar nuts [6] before loosening the clamp screws [7] on the right fork leg.

Hold the front wheel and withdraw the wheel spindle [8].

NOTE: The wheel spindle can be easily removed if you slightly revolve it with a ring spanner (SW 27 mm).

Carefully remove the front wheel from the fork.

### ! CAUTION

- Do not operate the hand brake when the front wheel has been dismounted.
- Always place the wheel on the ground with the brake disc pointing upwards. Otherwise the brake disc may be damaged.

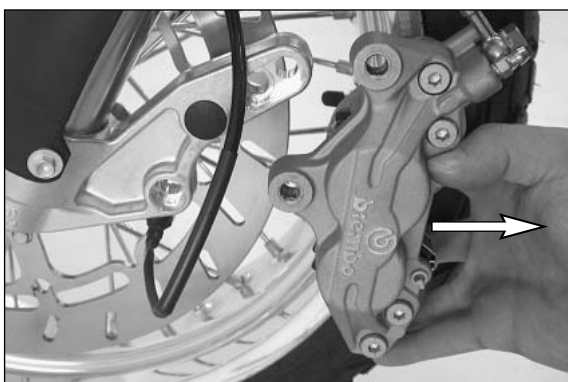

To install the front wheel, lift it into the fork, position and mount the axle shaft. Mount the collar nut [6], tighten the clamping screws [7] on the right fork leg axle passage to prevent the axle shaft from turning and tighten the collar nut to 40 Nm.

After mounting the front wheel, slide the brake caliper to the brake disc. Remove the grease from the threads of both screws [4] and apply Loctite 243. Tighten the screws with 40 Nm.

Loosen the clamp screws on the right fork leg. Take the motorcycle down from its stand. Press the front wheel brakes and push down on the fork a few times vigorously so that the fork legs come into alignment.

Only after this has been accomplished, tighten the clamp screws on both fork legs with 15 Nm.

### ⚠ WARNING

- If you don't happen to have a torque wrench at hand, make sure you have the tightening torque corrected by a KTM dealer as soon as possible. A loose axle may lead to an unstable driving behavior of your motorcycle.
- After mounting the front wheel, keep operating the hand brake until the pressure point returns.
- It is very important to keep the brake disc free from oil and fatty matters, otherwise the braking effects would be strongly reduced.
- The screws 1 must be secured with Loctite 243.

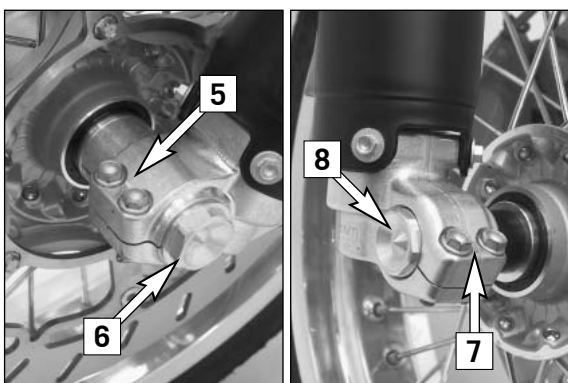



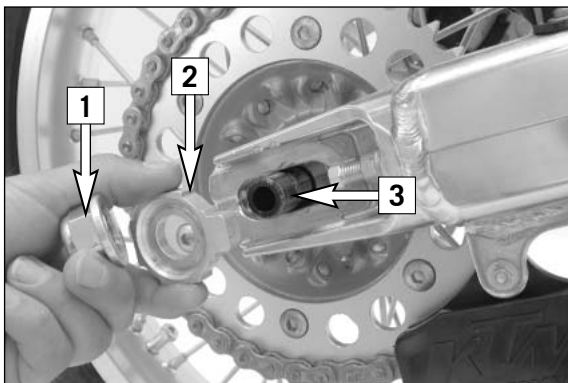

## Dismounting and mounting the rear wheel

Park the motorcycle on the center stand. The rear wheel must not touch the ground.

Loosen the collar nut [1], remove chain tensioner [2], hold the rear wheel and pull out the wheel spindle [3] until the rear wheel is free but the brake caliper support is still held. Push the rear wheel as far forward as possible, take the chain from the rear sprocket and carefully take the rear wheel out of the swingarm.

### ! CAUTION

- Do not operate the rear brake when the rear wheel has been dismantled.
- Always place the wheel on the ground with the brake disc pointing upwards. Otherwise the brake disc may be damaged.
- If the axle is dismantled, clean the thread of the wheel spindle and collar nut thoroughly and apply a new coat of grease (Motorex Long Term 2000) to prevent the thread from jamming.

The rear wheel is remounted in reverse order. Before tightening the collar nut to 80 Nm (60 ft.lb), push the rear wheel forwards so that the chain tensioners lie on the tension screws.

### ⚠ WARNING

- If you don't happen to have a torque wrench at hand, make sure you have the tightening torque corrected by a KTM dealer as soon as possible. A loose axle may lead to an unstable driving behavior of your motorcycle.
- After mounting the rear wheel, keep operating the rear brake until the pressure point returns.
- It is very important to keep the brake disk free from oil and fatty matters, otherwise the braking effects would be strongly reduced.

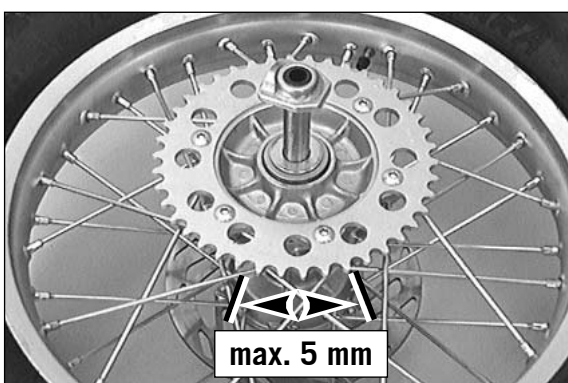
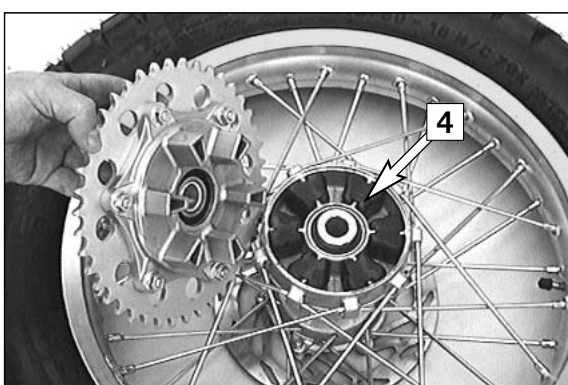

## Checking the shock absorption rubbers in the rear hub

LC4 models have a damped rear wheel hub. For this purpose, the engine power is conveyed from the rear sprocket via 6 shock absorption rubbers [4] to the rear wheel. These 6 absorption rubbers wear with increasing operation time, and should be checked for wear whenever the rear wheel is dismantled.

For this purpose, lie the rear wheel on a work bench with the rear sprocket upwards, and put the wheel spindle in the hub. Now hold the rear wheel firmly and try to turn the rear sprocket. The rear sprocket may not turn more than maximum 5 mm (0.2 in) measured on the outside. If the play in the chain wheel is larger, all 6 shock absorption rubbers are to be replaced. Check the shock absorption rubbers for signs of damage and dirt.

### ! CAUTION

If the shock absorption rubbers are not replaced in good time, the rear sprocket carrier and the rear hub will be damaged. Always replace all 6 absorption rubbers, never single rubbers.



## Tires, air pressure

Tire type, tire condition, and air pressure level affect the way your motorcycle rides, and they must therefore be checked whenever you are getting ready to go anywhere on your motorcycle.

Tire size can be found in the technical specifications and in their homologation certificate

Tire condition has to be checked every time you want to ride your motorcycle. Before leaving, check tires for punctures and nails or other sharp objects that might have become embedded in them.

Refer to the specific regulations in your country for minimum tire tread requirements. We recommend you replace the tires at the latest when the tread is down to 2 mm.

Tire pressure should be checked regularly on a "cold" tire. Proper pressure ensures optimum driving comfort and extends the life of your tires.

### ⚠ WARNING

- Do not mount tires which have not been approved by KTM. Other tires could have adverse effects on the way your motorcycle behaves.
- front and rear wheels may only be fitted with tires having the same tread layout. Use homologated tires.
- For your own safety replace damaged tires immediately.
- Worn tires can have a negative effect on how your motorcycle performs, especially on wet surfaces.
- If air pressure is too low, abnormal wear and overheating of the tire can result.

TIRES - AIR PRESSURE SXC		
	front	rear
Offroad	1,0 - 1,5 bar	1,0 - 1,5 bar
Road	2,0 bar	2,0 bar

TIRES - AIR PRESSURE SMC		
	front	rear
SM-Racing	1,5 bar	1,6 bar
Road	2,0 - 2,2 bar	2,2 - 2,4 bar



## Checking spoke tension

The correct spoke tension is very important for the stability of the wheels and thus for riding safety. A loose spoke causes the wheel to become unbalanced and before long other spokes will have come loose. Check spoke tension, especially on a new motorcycle, in regular intervals. For checking, tap on each spoke with the blade of a screwdriver (see photo). A clear tone must be the result. Dull tones are indicators of loose spokes. If necessary, have the spokes retightened and the wheel centered by a KTM dealer.

### ⚠ WARNING

- Spokes can tear if you continue to ride with them loose. This may lead to an unstable handling of your motorcycle.
- Excessively tensioned spokes may rupture due to local overloading. The spokes must be tensioned to 5 Nm.

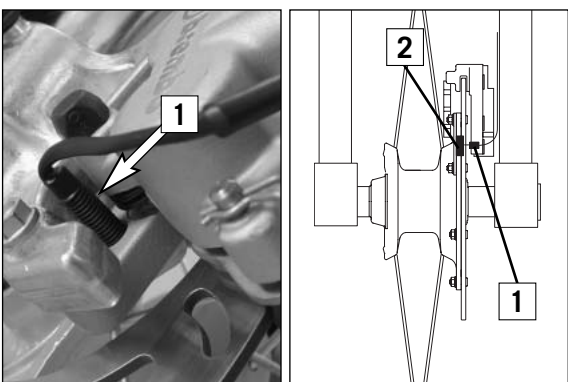

## Check/set distance of the magnetic sensor

The distance between magnet [2] and sensor [1] must be 2-4 mm, otherwise malfunctions on the speedometer might occur.

This distance can be corrected by screwing in or off the sensor [1].

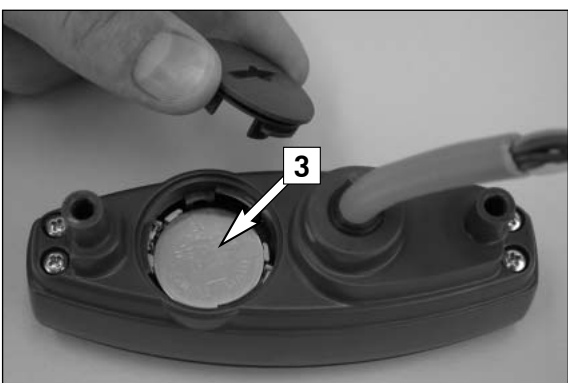

## Battery for digital speedometer

To prevent the speedometer settings from being lost when the vehicle battery is disconnected, an extra battery can be inserted in the speedometer.

To insert, remove the headlight mask and dismount the electronic speedometer. Remove the screw connection [3], insert the battery (type Duracell CR 2430) with the writing facing up and remount the screw connection.

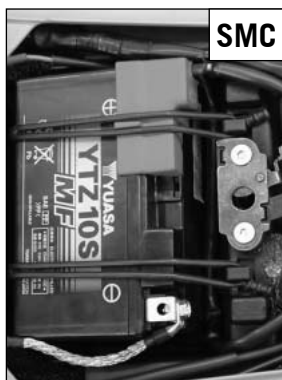
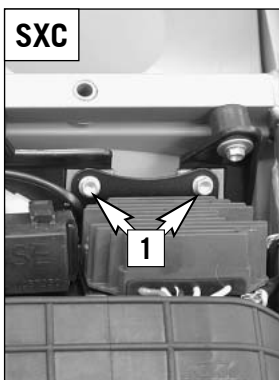

## Battery (SXC)

The battery is located under the seat and is maintenance-free. It is not necessary to check the electrolyte level or to refill water. Simply keep the battery poles clean and slightly grease them with an acid-free grease if necessary.

Removing the battery:

Remove screws [1] and swing retaining bracket and voltage regulator out of the way.

First disconnect the negative and then the positive pole of the battery.

Remove battery.

When replacing, connect first the positive and then the negative pole.

## Battery (SMC)

The battery is located under the seat and is maintenance-free.

It is not necessary to check the electrolyte level or to refill water. Simply keep the battery poles clean and slightly grease them with an acid-free grease if necessary.

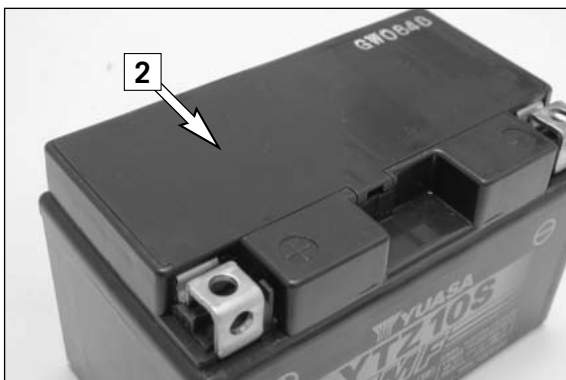

### ⚠ WARNING

- If electrolyte (sulphuric acid) leaks from the battery, proceed with great care. The electrolyte can cause severe burns.
- In the case of skin contact rinse thoroughly with water.
- In the case of contact with the eyes, thoroughly rinse eyes with water for at least 15 minutes. Immediately consult a doctor.
- The battery is a closed model but can nevertheless emit explosive gases. Avoid sparks and open fire near the battery.
- Defective batteries must be stored out of the reach of children. Ensure proper disposal of discarded batteries.

### ! CAUTION

- To avoid damage, do not remove the locking bar [2].
- Never disconnect the battery while the engine is running. This will destroy the rectifier-regulator.
- The battery must be installed with the terminals facing the front (as shown in the illustration), otherwise electrolyte can escape.



### BATTERY STORAGE:

When preparing the motorcycle for a longer period of standstill, remove the battery and recharge it. Storage temperature: 0 - 35°C (30 - 95°F). Do not expose to direct sunlight.

## Charging the battery

NOTE: A battery charger, item no. 58429074000 is available from your KTM dealer.

You can also use the battery charger to test the battery's off load voltage, startability and the generator capacity.

Remove the battery and check the charging level. Use a voltmeter to measure the voltage between the battery poles (off-load voltage).

Accurate results can only be obtained if the battery has neither been charged nor discharged during a period of 30 minutes preceding the measuring.

Recharging is not required if the voltage exceeds 12.4 V.

Recharge if the voltage is below 12.4 V.

### CHARGING:

Charge the battery for 5 to a max. of 10 hours with 0.9 amperes and a max. of 14.4 volts.

For a quick charge, do not charge the battery longer than 1 hour with 4.5 amperes and a max. of 14.4 volts.

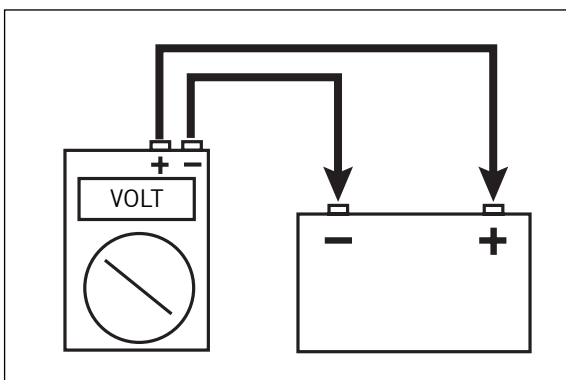

### ! CAUTION

- If the charge condition cannot be established, the battery may only be charged 5 to a max. of 10 hours with 0.9 amperes and a max. of 14.4 volts.
- Always connect the battery to the charging unit before turning the charging unit on.
- When recharging the battery in closed rooms there is sufficient ventilation. Explosive gases are released during the battery charging process.
- Charging time and charging voltage should not exceed the stated values. Otherwise electrolyte will be released through the safety valves.
- Avoid quick charging if possible.
- To avoid damage, do not remove the locking bar.





# MAINTENANCE WORK ON CHASSIS AND ENGINE »

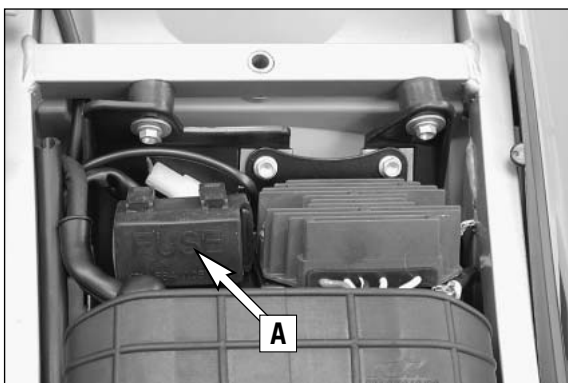

## Fuses

Fuse box [A] is located under the seat. See "Removing the seat" to remove and mount the seat. The fuses are numbered on the inside of the fuse box. The fuses marked "RES" are spare fuses.

FUSE	SMC	SXC
1	10 Ampere – electronic speedometer – capacitor	20 Ampere protects all power consumers against short circuits.
2	10 Ampere – ignition – starter system	10 Ampere – electronic speedometer – capacitor
3	10 Ampere – flasher lights – brake light – horn	10 Ampere – ignition – starter system
4	10 Ampere – headlight – parking light	10 Ampere – flasher lights – brake light – horn
5	–	10 Ampere – headlight – parking light

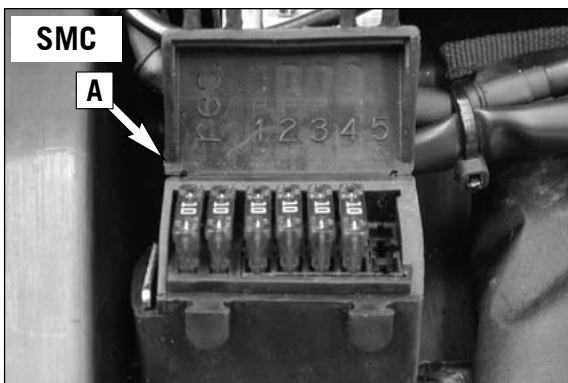
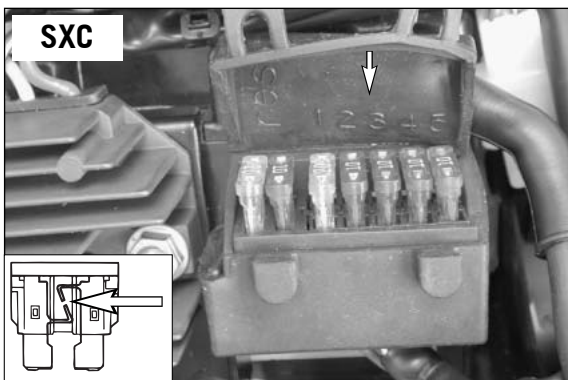

Replace a blown fuse only with an equivalent one. If a new fuse that has just been set in gets blown again, you are strongly advised to have it inspected by a KTM dealer.

## ! CAUTION

Under no circumstances is a stronger fuse allowed to be set in or a fuse allowed to be "repaired". An inexpert treatment could damage the whole electrical installation!



## Replacing headlight lamp/parking light lamp

Loosen both rubber bands [1] and tilt headlight mask to the front.

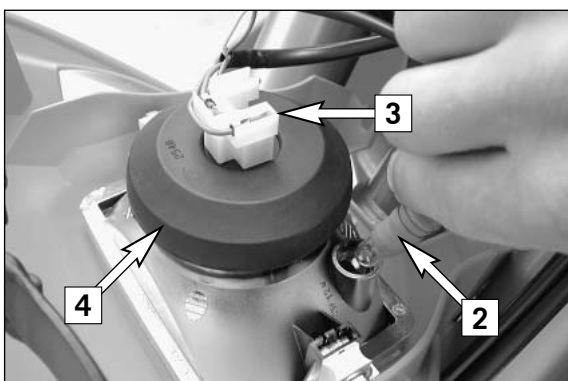

Pull the parking light lamp with holder [2] carefully out of the reflector. Pull connector [3] off the headlamp and remove rubber cap [4]. Disengage retaining clip and take bulb out of reflector. When changing the parking-light lamp, simply pull it out of the holder.

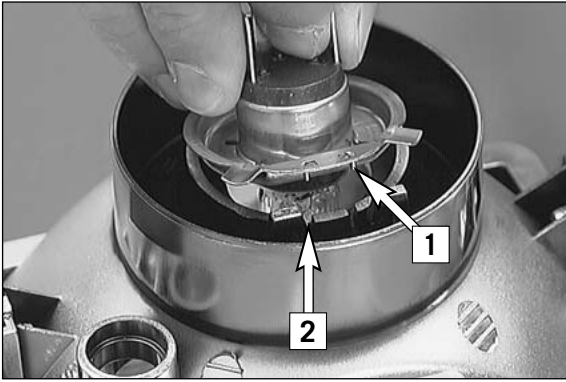

Insert the new lamp such that the noses [1] engage in the recesses [2]. When doing so, do not touch the glass body of the lamp so that it remains free from fat. Engage retaining clip, mount rubber cap and connector. If the parking-light lamp is to be replaced, simply insert it in the holder. Reinsert the parking-light lamp together with the holder. Engage the bottom end of the headlamp mask at the retaining pins and fix the mask by means of the rubber bands.

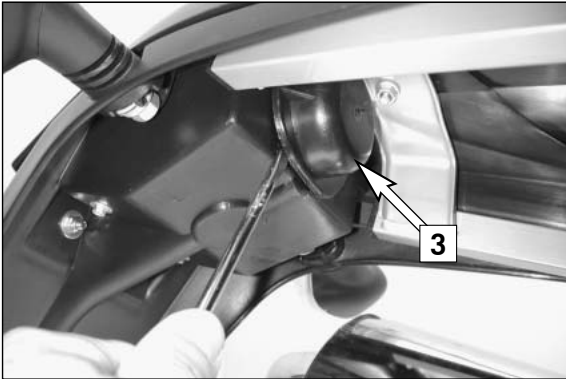

## Exchanging the brake light and tail light bulb (SXC)

Remove the cap [3] on the underside of the license plate retainer.

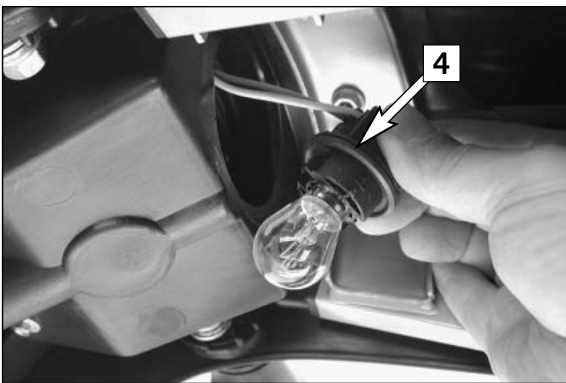

Turn the lamp socket [4] approximately 30° counterclockwise and pull it out of the tail light housing.

Slightly depress the bulb, turn it approx. 30° counterclockwise and pull it out of the socket.

To mount the lamp reverse the worksteps indicated above.

NOTE: Since the bulb on the tail end is subjected to higher vibrations, heavy-duty bulbs are available from your KTM dealer.

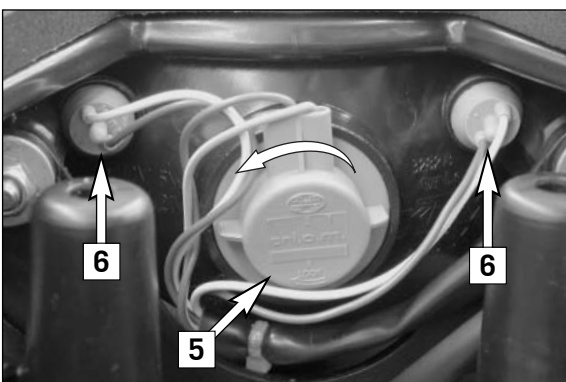

## Exchanging the brake light and tail light bulb (SMC)

Remove seat.

Disengage retaining clip [5] and take bulb out of reflector. When changing the brake-light lamp, simply pull it out of the holder.

Slightly depress the bulb, turn it approx. 30° counterclockwise and pull it out of the socket.

To mount the lamp reverse the worksteps indicated above.

When changing the tail-light lamp [6], simply pull it out of the holder.



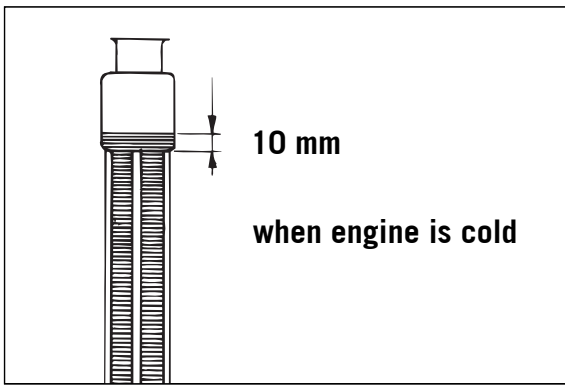

## Checking the coolant level

The coolant should be 10 mm (0.4 in) above the radiator fins when the engine is cold (see illustr.). In the event of the coolant being drained, always fill and bleed the system.

## Cooling system

Coolant is circulated by a water pump located in the engine. When the engine is cold the coolant circulates only through the cylinder and the cylinder head. After the engine has reached its operating temperature (about 70°C, 158°F), the thermostat [1] opens and the coolant is also pumped through both aluminum radiators.

Air blowing in through the radiators cools the coolant. The slower the speed of the motorcycle, the less the coolant is cooled down. Dirty radiators also reduce the cooling efficiency.

### 625 SMC

If little or no air blows through the radiators, for example when riding through slow traffic or waiting at traffic lights, the coolant temperature will rise. If the coolant temperature rises to 98°C (208°F), the fan on the left radiator will switch on. This fan will provide additional air circulation through the radiator thereby preventing the cooling system from overheating.

### ⚠ WARNING

- If possible, always check level of cooling liquid when engine is cold. If you have to open the radiator cap 3 when the engine is hot, use a rag to cover the cap and open slowly to release pressure. Caution - scalding hazard !
- Do not detach any radiator hoses while the engine is hot. The escaping hot coolant and the steam may cause serious burns.
- In case you get burnt, hold the affected part of your body under running cold water right away!
- Coolant is toxic. Keep the coolant out of the reach of children!
- In case coolant is ingested, go see a doctor immediately!
- If coolant gets into your eyes, rinse them out with water immediately and go see a doctor!

### ! CAUTION

Possible causes of an overheated engine:

- Slow driving and heavy load at a high air temperature:  
Increase your driving speed if possible to allow wind to cool the radiator.
- Not enough cooling liquid in the system:  
Allow the engine to cool off and check the system for leaks. Also check the cooling liquid level, CAREFUL – RISK OF SCALDING!  
Only continue driving if there is enough liquid in the system. Stop at an authorized KTM workshop as soon as possible to have the defect eliminated. If you continue to drive with an overheated engine, you will damage the engine.
- The fan in the left radiator is not running:  
The fan should run from a cooling liquid temperature of 98°C (208°F) whenever the engine is running. If the fan is not running and you have enough cooling liquid, you can continue to drive to the nearest authorized KTM workshop, keeping the engine load to a minimum.
- Riding the clutch at lower speeds

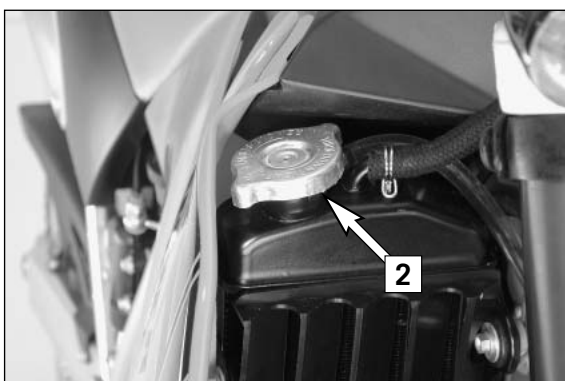
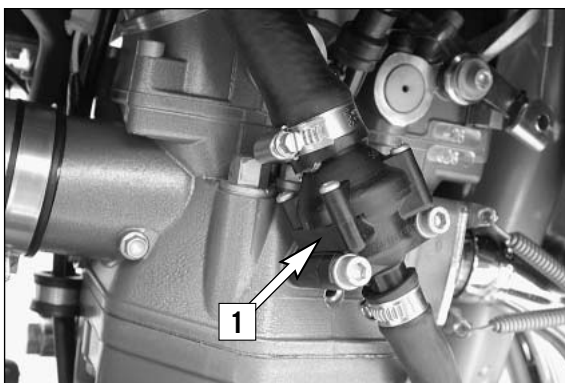

A mixture of 50% anti freeze liquid and 50% distilled water is used as coolant. However, the anti-freeze protection must be at least -25°C (-13°F). This mixture offers anti-freeze protection but also good corrosion protection and should therefore not be replaced by pure water.

### ! CAUTION

For the cooling system, use only with high-grade antifreeze (Motorex Anti Freeze). Using lower-grade antifreeze agents, can cause corrosion and coolant foaming.

Pressure induced by heating of the coolant in the system is controlled by a valve in the radiator cap [2]; a water temperature rising up to 120°C (248°F) is admissible, without fear of problems.

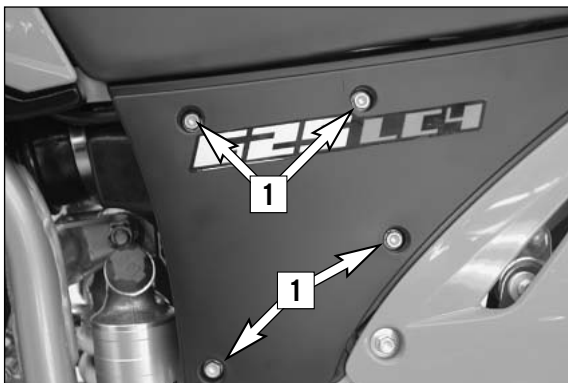

## Cleaning the air filter (SXC) \*

It is very important for the engine's life expectancy to clean the air filter regularly.

To clean the air filter, remove screws [1] and the filter box cover. Detach retaining clip [2] and remove the air filter [3] including the filter holder [4] from the filter box.

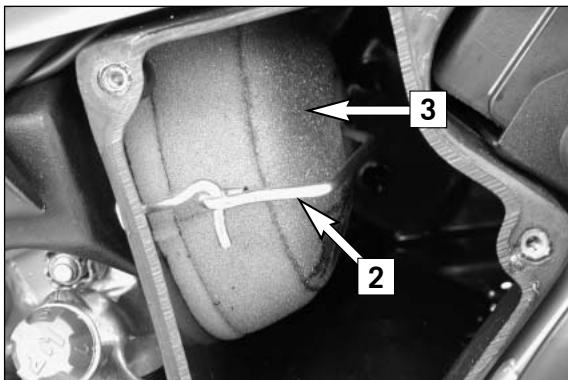

Remove the air filter from the filter holder and wash thoroughly in special cleaning fluid. Motorex offers environmentally-friendly products for professional oil filter maintenance (Motorex Bio Dirt Remover + Motorex Liquid Bio Power). Press out the water from the air filter but do not wring and allow the filter to dry. Lubricate the dry air filter thoroughly with highgrade filter oil, rubbing to coat the entire filter surface. Clean the filter box and cover and check the carburetor connection boot for damage.

### ! CAUTION

- Do not clean foam filter with fuel or petroleum since these damage the foam. KTM recommends the products of the company Motorex for air filter maintenance (Bio Dirt Remover and Liquid Bio Power).

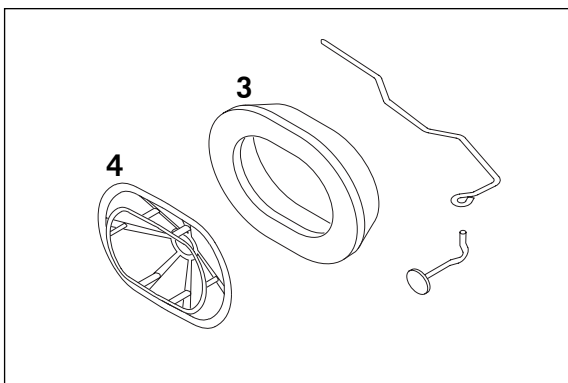

Mount the air filter on the filter holder, position in the filter box (make sure to center) and fix with the retaining clip. Check whether the air filter is positioned correctly and mount the filter box cover.

### ! CAUTION

- Do not clean air filter with fuel or petroleum since these will damage the foam. KTM recommends the products made by Motorex for air filter maintenance. for cleaning purposes and to oil the air filter.
- Dust and dirt can accumulate and damage the engine if the air filter is not mounted correctly.
- Never start your motorcycle without any air filters. Otherwise, dust and dirt may penetrate and cause damage and increased wear.

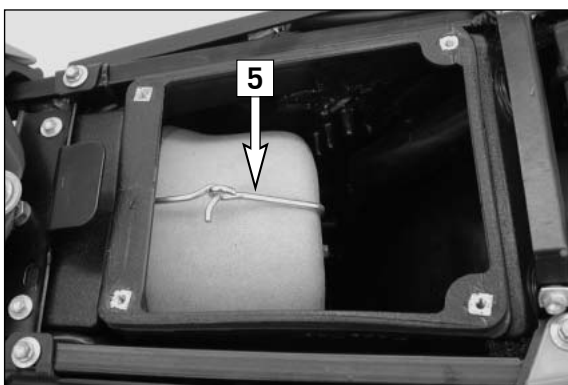

## Cleaning of air filter \*

To do this, remove the seat and the air filter cover from the air filter box. Unclip the filter holder [5], swing back and remove air filter plus filter carrier from the filter box.

Remove the air filter from the filter holder and wash thoroughly in special cleaning fluid. Motorex offers environmentally-friendly products for professional oil filter maintenance (Motorex Bio Dirt Remover + Motorex Liquid Bio Power). Press out the water from the air filter but do not wring and allow the filter to dry. Lubricate the dry air filter thoroughly with highgrade filter oil, rubbing to coat the entire filter surface.

Clean the filter box and cover and check the carburetor connection boot for damage.

Mount the air filter on the filter support [6]. Grease the front side [A] of the filter, to improve the seal. Mount the air filter and the filter support in the filter box. Make sure they are centered [B], and lock into place with the filter holder [5].

### ! CAUTION

- Do not clean air filter with fuel or petroleum since these damage the foam. KTM recommends the products of the company „Motorex“ for air filter maintenance.
- Never operate your motorcycle without air filter. Otherwise, dust and dirt may get into the engine and lead to increased wear.
- Having mounted the air filter, check it for correct fit. The front end A must about the air filter box. Otherwise, dust and dirt may get into the engine and lead to increased wear.

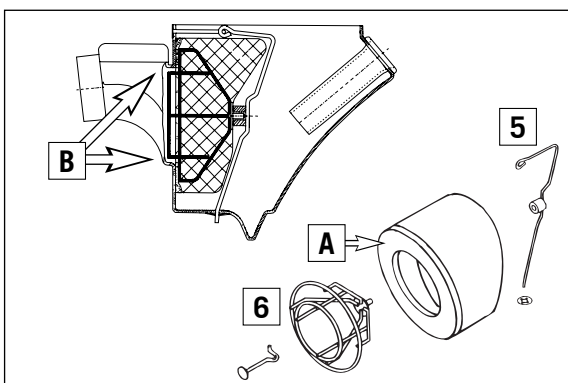



## Exhaust system (SXC) \*

Aluminium silencers are filled with glass fiber yarn. Have the filling checked regularly by an authorized KTM workshop (see Lubrication and Service Chart). The insulating material fibers escape through the holes in the perforated pipe with time, causing the silencer to „burn out“. In addition to causing a higher noise-level, it will also affect the power characteristic. The insulating material suitable for your exhaust is available from your authorized KTM workshop. Experience has shown that the front glass fiber pack [1] must be replaced more often than the rear pack [2].

To replace the front glass fiber yarn pack, remove the silencer. Remove the front cap [3], pull the front glass fiber yarn pack out of the silencer, mount a new pack on the internal exhaust pipe, insert the internal exhaust pipe [4] into the silencer and replace the cap.

To replace the rear glass fiber yarn pack, drill the rivets open and remove the rear cap [5].

NOTE:

Always renew the O-rings [6].

Glass fiber yarn packs are available in your KTM store.

### **⚠ WARNING**

**The exhaust system becomes very hot while the motorcycle is running. to avoid burns Do not start work on the exhaust system until it has properly cooled down.**

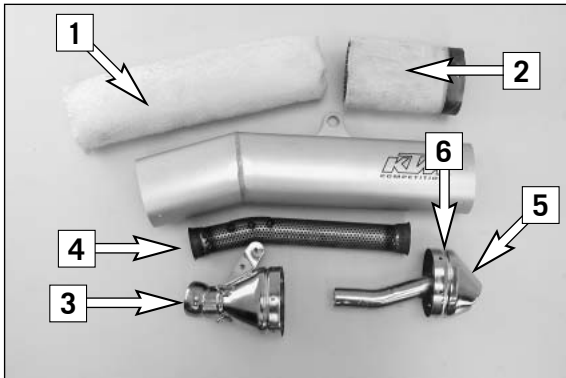

## Exhaust system (SMC) \*

625 SMC silencers are filled with glass-fiber yarn in the front and insulation matting in the rear for dampening. The influence of heat causes the glass-fiber yarn to become loose. This can lead to a loss of power and reduce the silencer's dampening effect, therefore only the front glass-fiber yarn set [7] must be replaced.

To replace, detach the silencer from the motorcycle and remove the front cap [8]. Pull the front glass-fiber yarn set including the inner exhaust pipe [9] out of the silencer. Clean the front inner exhaust pipe.

Slide a new set into the silencer. Replace O-Ring [10]. Then push the inner exhaust pipe into the silencer and mount the cap. Have the filling checked regularly by an authorized KTM workshop (see Lubrication and Service Chart). The insulating material fibers escape through the holes in the perforated pipe with time, causing the silencer to „burn out“. In addition to causing a higher noise-level, it will also affect the power characteristic. The insulating material suitable for your exhaust is available from your authorized KTM workshop.

### **⚠ WARNING**

**The exhaust system becomes very hot while the motorcycle is running. to avoid burns Do not start work on the exhaust system until it has properly cooled down.**

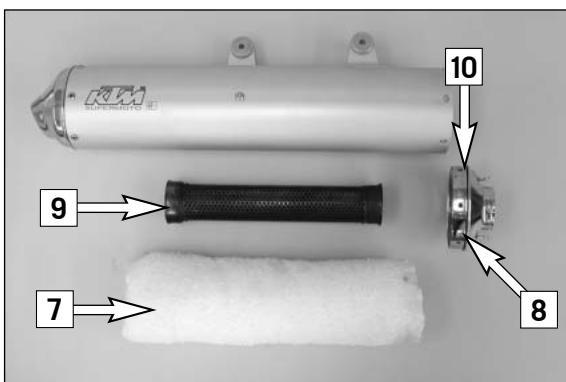

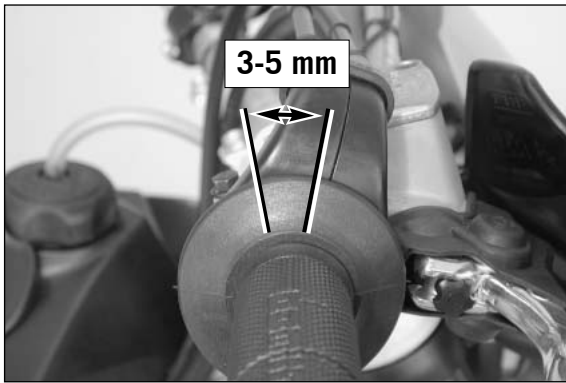

## Adjusting the throttle cable \*

The throttle grip should always provide for a backlash of 3-5 mm (0.12-0.20 in). Besides, with the engine running, the idling speed must not change if you turn the handlebar all the way to the left or right.

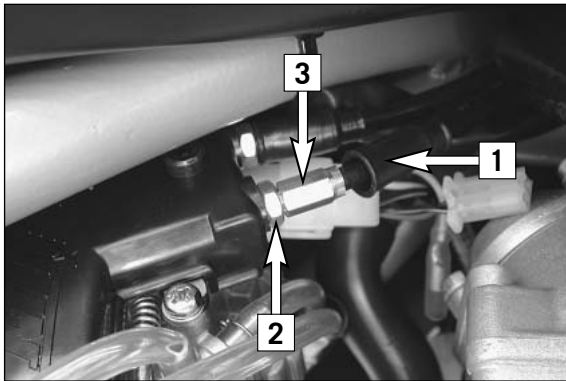

To adjust the throttle cable, push back the protection cover [1], loosen the counter nut [2] and turn the adjusting screw [3] as required. Turning the adjusting screw counterclockwise will reduce the backlash, turning the adjusting screw clockwise will increase the backlash.

Tighten the counter nut and check whether the throttle grip can be actuated smoothly.

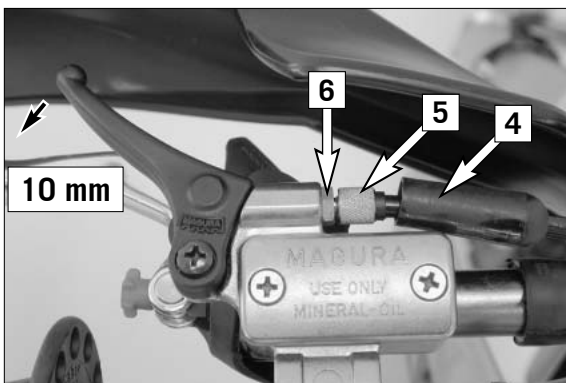

## Checking the adjustment of the hand decompression cable \*

To check, set piston at compression, so that the valves are closed. While doing this, slowly operate the kickstarter through its stroke until the clicking sound (disengaging) of the automatic decompression can be heard. Now the decompression lever must be operated 10 mm until resistance is felt (the exhaust valves begin to open).

To adjust, move back the protective cover [4], loosen the counter nut [5] and correct the adjustment screw [6] accordingly. Tighten counter nut and push back protective cover.

### ! CAUTION

The setting of the decompression cable should be checked regularly. If there is no play in the deko-lever, this can result in engine damage.

NOTE:

No adjustment need be made to the automatic decompressor.



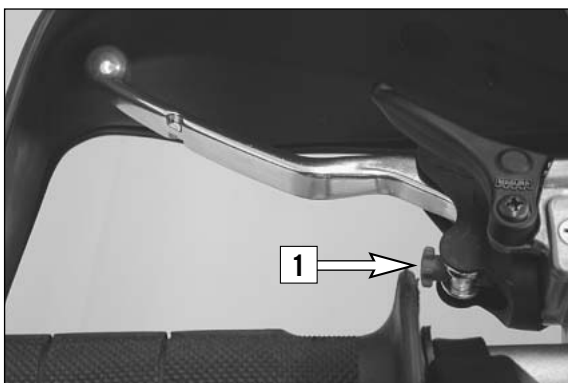

## Changing the original position of the clutch lever

The adjusting screw [1] can be used for individual adjustment of the original position of the clutch lever, thus allowing adjustment to an optimal position for every hand size.

Turning the adjusting screw counterclockwise reduces the distance between the clutch lever and the handlebar. Turning the adjusting screw clockwise increases the distance between the clutch lever and the handlebar.

### ! CAUTION

Adjustment of the clutch lever position is only possible within certain limits. Only turn the adjusting screw manually and never apply excessive force.

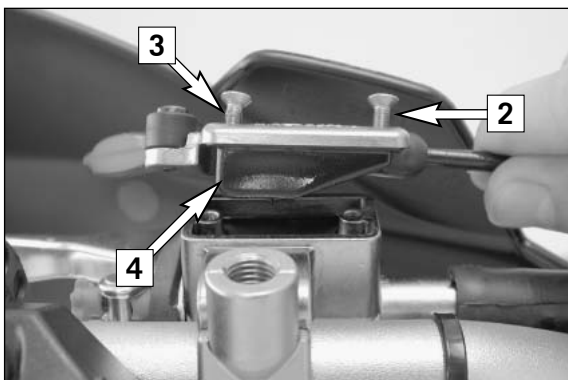

## Checking the oil level of the hydraulic clutch

To check the oil level in the master cylinder of the clutch remove the cover. For this purpose, remove screws [2] and cover [3] together with the rubber boot [4]. The oil level in the horizontal-standing master cylinder should be 4 mm below the upper edge.

If necessary, fill up with biodegradable hydraulic oil SAE 10 (e.g. Motorex Kupplungsfluid 75). Biodegradable hydraulic oil is available from your KTM dealer (50ml).

### ! CAUTION

KTM uses biodegradable, hydraulic mineral oil to actuate the hydraulic clutch. Do not mix this oil with any other hydraulic oil. Always use original KTM hydraulic oil (available from your authorized KTM workshop) to make sure your clutch operates smoothly. Never refill with brake fluid.

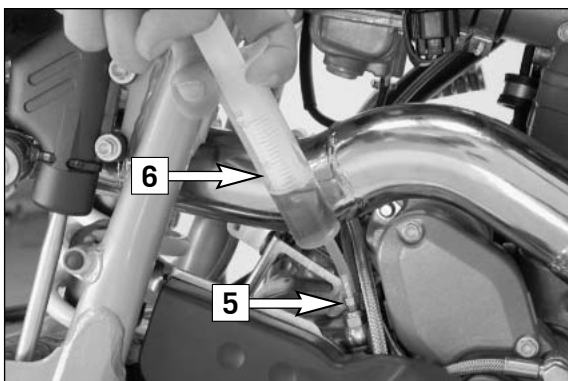

## Bleeding of the hydraulic clutch

To bleed, the cover of the master cylinder of the clutch needs to be removed. For this purpose, remove screws [2] and take off cover [3] together with rubber bellows [4]. At the slave cylinder of the clutch, remove the bleeder nipple [5]. In its place, mount the bleeder syringe [6] which is filled with SAE 10 hydraulic oil. Refill oil until oil is discharged from the bore [7] of the master cylinder in a bubble-free state. Make sure that the oil does not overflow. The bleeder syringe can be purchased from your KTM dealer. Having completed the bleeding procedure, you have to verify that the oil level in the master cylinder is correct. If necessary, fill up with biodegradable hydraulic oil SAE 10 (e.g. Motorex Kupplungsfluid 75). Biodegradable hydraulic oil is available from your KTM dealer (50ml).

### ! CAUTION

KTM uses biodegradable, hydraulic mineral oil to actuate the hydraulic clutch. Do not mix this oil with any other hydraulic oil. Always use original KTM hydraulic oil (available from your authorized KTM workshop) to make sure your clutch operates smoothly. Never refill with brake fluid.

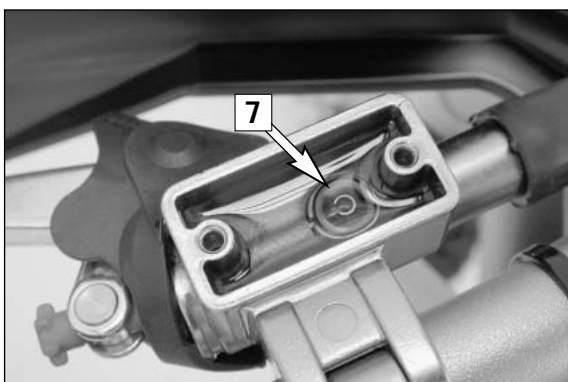



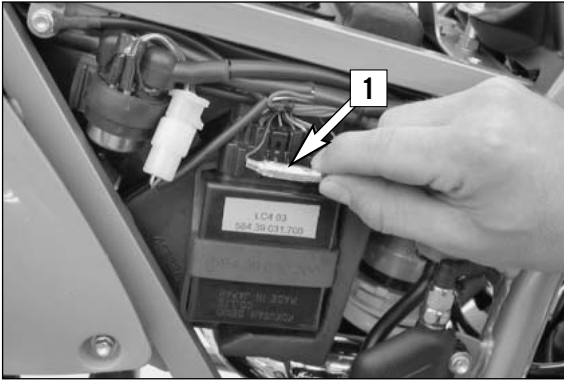

## Activating the ignition curve for low-octane fuel (SMC)

If you are traveling to a country where fuel having at least 95 octane (ROZ) is not available, you can easily activate the corresponding ignition curve. A socket connector [1] is located on a brown-black cable near the digital box. If the two connectors are connected to each other, the ignition curve for fuel having at least 95 octane (ROZ) is activated.

If you disconnect the plug and socket connection, the ignition curve for fuel having 80 - 94 octane (ROZ) is activated. Although this causes the engine to lose some of its power output, it prevents poor glow ignitions and engine damage.

### ! CAUTION

If fuel having at least 95 octane (roz) is not available, the ignition curve for 80 - 94 octane (roz) must be activated to prevent engine damage.

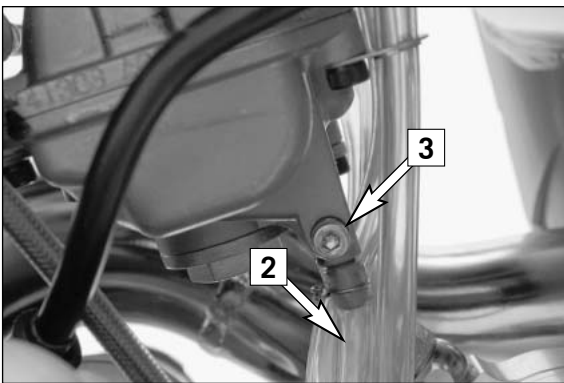

## Draining the float chamber of the carburetor

Following every wet cleaning procedure, the float chamber of the carburetor should be drained in order to remove any water that may have penetrated into it. Water in the float chamber causes malfunctioning. Perform this task on a cold engine.

Close the fuel tap and put one end of the hose [2] into a collecting vessel.

Open the drain plug [3] (turning it counterclockwise) by several turns, and drain the fuel from the float chamber.

Then, retighten the drain plug and open the fuel tap.

### ⚠ WARNING

- Fuel is easily flammable and toxic. When handling fuel, be sure to exercise the utmost caution. Never perform any work on the fuel system in the proximity of open flames or burning cigarettes.
- Always allow the engine to cool off first. Immediately clean up any fuel which may have been spilled. Materials saturated with fuel are also easily flammable. In case you ingested fuel or fuel splashed into your eyes, consult a doctor immediately.
- Dispose the fuel properly!

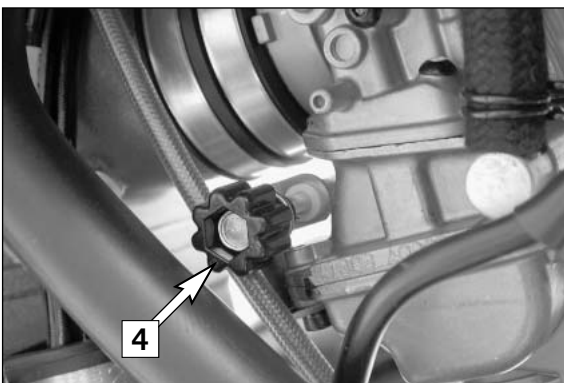

## CARBURETOR – Adjust idling \*

Idling adjustment of the carburetor strongly affects the engine's starting behavior. That is, an engine whose idling speed is adjusted correctly will be easier to start than one whose idling speed has not been adjusted correctly.

The idle speed is controlled by means of the adjusting wheel [4] and the mixture control screw [5]. The adjusting wheel is used to adjust the basic setting of the slide. The mixture control screw is used to control the idle mixture which arrives at the engine by way of the idle system. Clockwise turning reduces the fuel quantity (lean mixture), counterclockwise turning increases the fuel quantity (rich mixture).

To adjust idling correctly, proceed as follows:

- 1 Turn in mixture control screw [5] up to the stop, and turn it back out to the basic position (see technical data-engine)
- 2 Warm up the engine
- 3 Use the adjusting wheel [4] to set the normal idle speed (1400 - 1500 rpm).
- 4 Turn mixture control screw [5] slowly clockwise until idling speed starts to decrease. Memorize this position, and turn mixture control screw slowly counterclockwise until the idling speed decreases again. Adjust the point of the highest idling speed between these two positions. If, in the course of this procedure, the speed undergoes a relatively high increase, reduce the idle speed to a normal level and repeat the procedure specified in 4. Serious competitive racers will choose a setting approx. 1/4 turn (clockwise) leaner than this ideal value because their engine will heat up more when used in competitions.

NOTE: If you fail to obtain a satisfying result by following the procedure described above, an incorrectly dimensioned idling nozzle may be the cause. If:

- a) the mixture control screw has been screwed in up to the stop without causing any change in rotational speed, a smaller idling jet has to be installed.

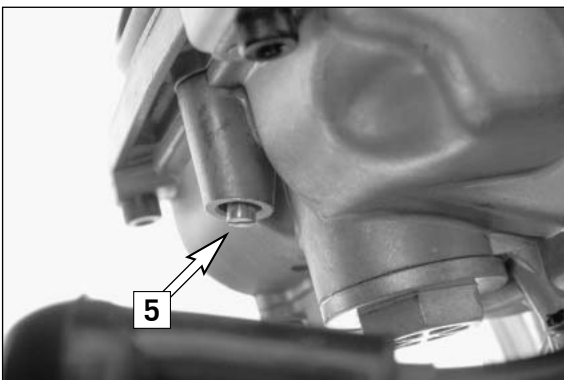

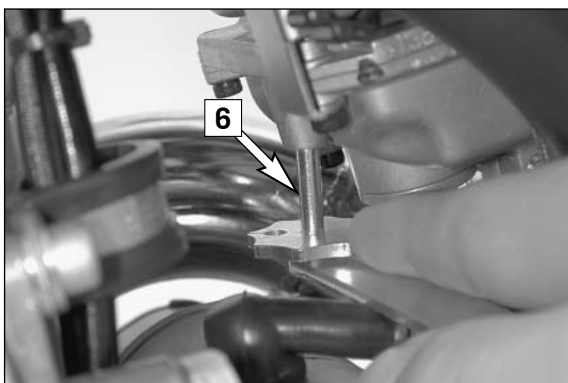

- b) the engine dies when the mixture control screw is still open by 2 turns, a larger idling jet needs to be selected.  
 Naturally, in cases of jet changes, you have to start your adjusting work from the beginning.
- 5 Then, use the adjusting wheel to set the desired idle speed.
  - 6 In cases of greater changes in the outside temperature and extremely different altitudes, the idling speed should be readjusted.

### BASIC INFORMATION ON CARBURETOR WEAR

As a result of engine vibrations, the throttle valve, jet needle, and needle jet are subjected to increased wear. This wear may cause the carburetor to malfunction (e.g., overly rich mixture). Therefore, these parts should be replaced after 200 hours.

### Adjusting the mixture control screw \*

Introduce the special tool on the mixture control screw [5] at the carburetor bottom. Press the tool slightly upward and turn the adjusting wheel [6] until the tool engages the slot of the mixture control screw. Now, you can go about adjusting the screw. Marks were provided on the adjusting wheel, making it easier to keep track of the turns.

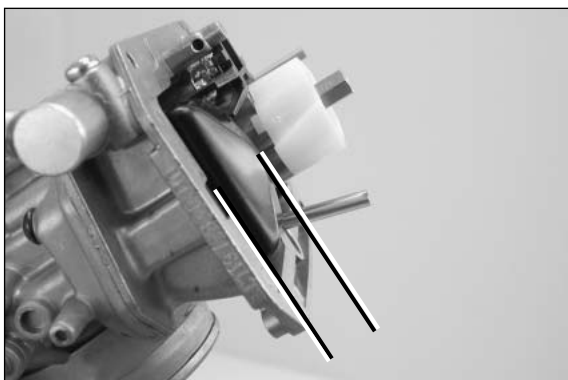

### Checking the float level (float height) \*

For this purpose, dismount the carburetor and remove the float chamber. Hold the carburetor in a slanted position such that the float will abut the float needle valve but not compress it. In this position, the edge of the float should be parallel with the float chamber sealing surface (see illustration). If the float height does not correspond to the desired value, check the float needle valve and, if necessary, replace it.

If the float needle valve is o.k., you can adjust the float height by bending the float lever [7].

Mount the float chamber, install the carburetor, and adjust the idle speed.

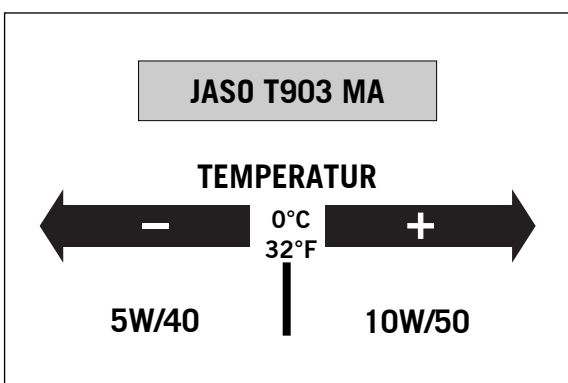
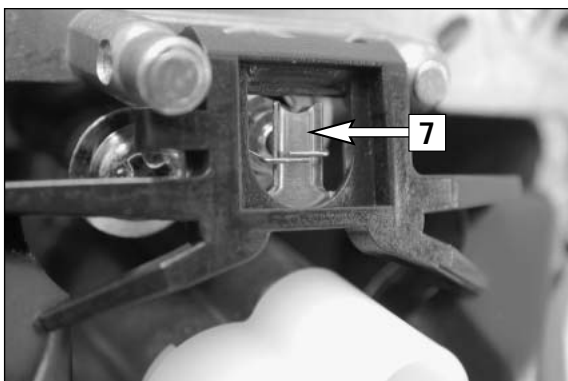

### Engine oil

Automobile engine oil used to be used for four-stroke motorcycles before there were separate motorcycle specifications. Different technical developments made it necessary to have a separate specification for four-stroke motorcycles - the JASO T903 MA standard. Whereas car engines require long changing intervals, motorcycle engines require a higher power output at higher speeds. Most motorcycle engines also use the same oil to lubricate the transmission and the clutch. The JASO MA standard responds to these special requirements. Only use fully synthetic engine oils that meet the JASO MA quality requirements (see information on the can).

KTM recommends Motorex Power Synt 4T in the 10W/50 viscosity (for temperatures over 0°C, 32°F) or 5W/40 (for temperatures under 0°C, 32°F).

### Checking the engine oil level

The engine oil level can be checked when the engine is cold or warm. To check, place the motorcycle in an upright position on a level surface (center stand).

If the engine is cold, the oil level should be visible at the lower edge [A] of the inspection glass.

If the engine is warm, the oil level should be visible at the upper edge [B] of the inspection glass.

Add engine oil if necessary.

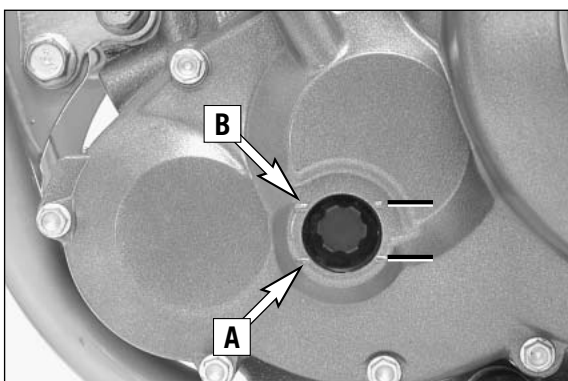

### ! CAUTION

- Insufficient amounts of or low-grade engine oil lead to premature wear in the engine.
- Do not overfill the engine case.
- Do not underfill the engine case.

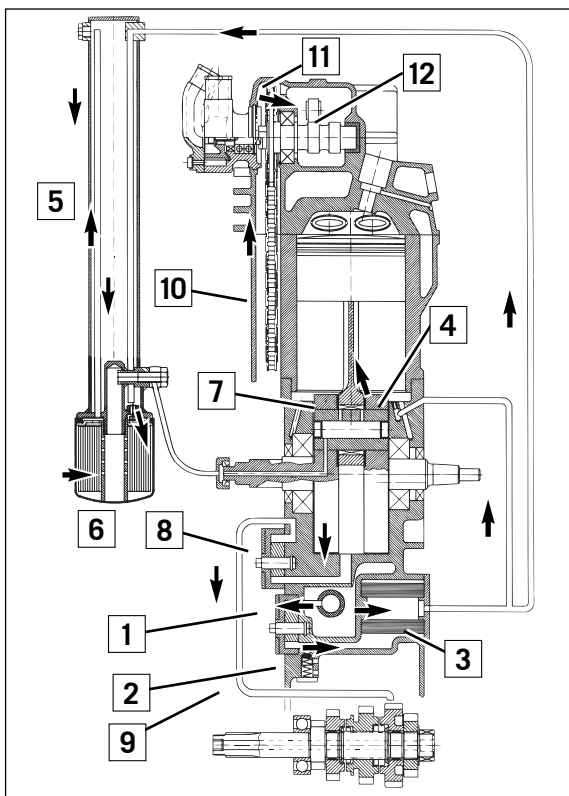

## Oil circuit

The oil pump [1] pumps the motor oil past the bypass valve [2] and through the oil filter [3]. Beyond the oil filter, one of the oil lines forks off to a jet [4] that injects motor oil to the piston pin bearing and the piston head. The second oil line leads the main oil flow to the frame breast pipe [5] where the motor oil is cooled off. Then the motor oil flows through the fine screen filter [6] that removes even the finest of contaminants from the motor oil. The cleansed motor oil is pumped via an oil line and the clutch cover into the crankshaft to the conrod bearing [7] and drains from there into the crank case. A additional oil pump [8] suctions the motor oil out of the crank case and pumps it through the oil canal [9] to the gear wheels of the 4th and 5th gears. The motor oil reaches the oil sump via the gear wheels. The timing chain [10] also dips into the oil sump and propels motor oil upwards to the cylinder head. The motor oil reaches the camshaft [11] and the valves through the bore [12].

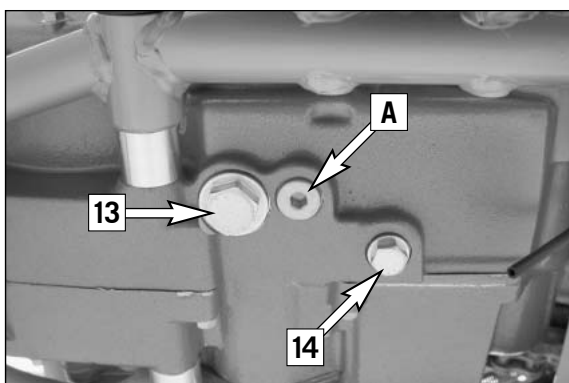

## Oil and screen filter change, bleeding of the oil system \*

Note: The frame breast pipe is integrated into the oil circuit for the sake of more effectively cooling the motor oil. It is thus important when changing the oil to also remove the fine screen filter, to drain the motor oil from the breast pipe and to de-aerate the oil system.

If the oil system is not bled at all or bled insufficiently, the bearings of the engine will not get enough lubrication, which in turn may result in engine failure.

Therefore, we recommend that you have the engine oil changed by your authorized KTM mechanic. During the guaranty period, the oil change must be performed by an authorized KTM mechanic. Otherwise, the guarantee will become void.

The engine oil change is to be carried out when the engine is still warm.

### ⚠ WARNING

**An engine having been run warm, and the engine oil in it is very hot - do not burn yourself.**

Place the motorcycle on a horizontal surface. Remove the two plugs [13] and [14], and drain oil into a container.

### ! CAUTION

**Plug A must not be removed, this is part of the by-pass valve.**

Remove the screws and the cover [15]. Loosen the fine screen filter [6] with an oil filter wrench and then screw it off by hand.

The screw [16] must be removed to allow the motor oil to flow out of the frame breast pipe.

Clean the plugs thoroughly with petroleum and compressed air in order to remove any metal filings. After the oil has drained completely, clean the sealing areas and remount the plugs together with their gaskets. Tighten plug [13] with 30 Nm and plug [14] with 20 Nm. Tighten the screw [16] with 10 Nm. Clean sealing surfaces on the frame breast pipe [17], fill new fine screen filter with engine oil, and oil rubber gasket [18]. Replace fine screen filter and screw it back in place, your bare hand will do.

Remove oil dipstick on the clutch cover, fill with 1.3 litre (0.34 US gallons) engine oil and attach plug again.

### ! CAUTION

- Use only original KTM fine screen filters. Using another filter brand can result in damage to the engine.
- If the engine oil has been drained from the front pipe of the frame, you must bleed the oil system!

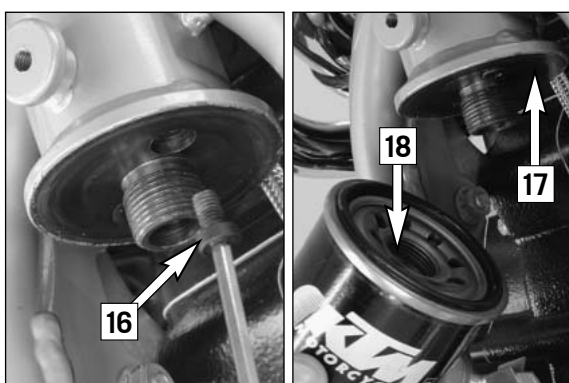
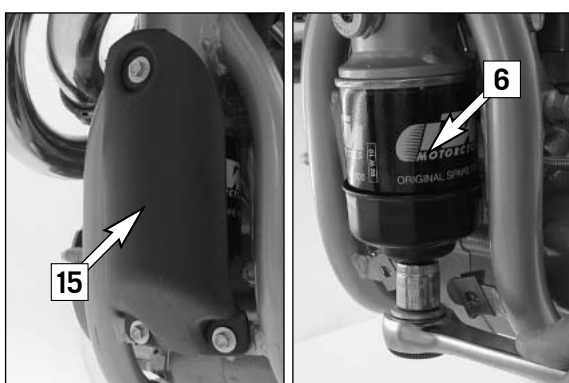



# MAINTENANCE WORK ON CHASSIS AND ENGINE »



To facilitate bleeding of the oil system, we have added a hose connection piece and a plastic hose to the set of tools. Take an empty oil can (1 liter) and drill a 7 mm (0.28 in) -diameter hole into the lid. Screw the hose connection piece into the lid from the outside, and secure it from the inside with the M8 hexagon nut.

Slip the plastic hose onto the hose connection piece, and you will have your filling tool.

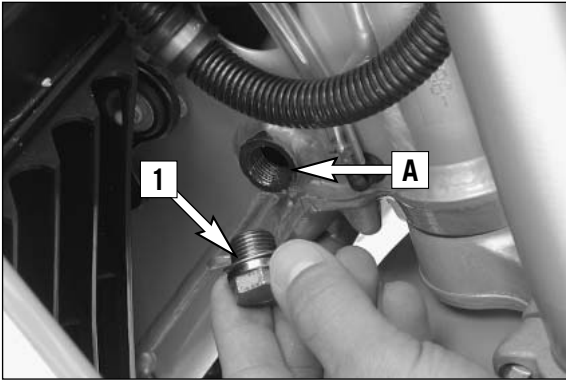

Fill 0.6 liters (0.16 US gallons) of engine oil into the can and remove the plug [1] next to the steering head. Introduce the plastic hose into the vent hole [A], (see page 30) and fill 0.6 liters (0.16 US gallons) of engine oil into the frame's front tube. Remove plastic hose, start engine, and let it idle (approx. 20 seconds) until oil escapes at the hole [A]. As soon as oil begins to leak out, switch off the engine, mount the plug and gasket and tighten to 25 Nm.

Let the motor run until it warms. Check the oil drain plugs and the fine screen filter to make sure they are properly sealed. Check the level of the motor oil. Place the motorcycle on a horizontal surface (main stand) and wait for 5 minutes. Checking the oil level, he should be between the two marks on the inspection glass, however, it must never rise above the MAX mark. Otherwise, engine oil would get into the air filter box by way of the engine venting system. Add engine oil, if necessary.

## ! CAUTION

- Insufficient oil or poor quality oil results in premature wear of the engine.
- Checking the engine oil level when the engine is cold results in a false reading on the oil dipstick and therefore an incorrect oil level.
- Do not overfill the engine case.
- Do not underfill the engine case.

Afterwards check the entire oil system and motor to make sure they are properly sealed. Attach the covering of the fine screen filter to the frame breast pipe.

Note: Dispose of used oil properly! Under no circumstances may used oil be disposed of in the sewage system or in the open countryside. 1 liter (0.264 US gallons) oil contaminates 1.000.000 liter (264.000 US gallons) water.

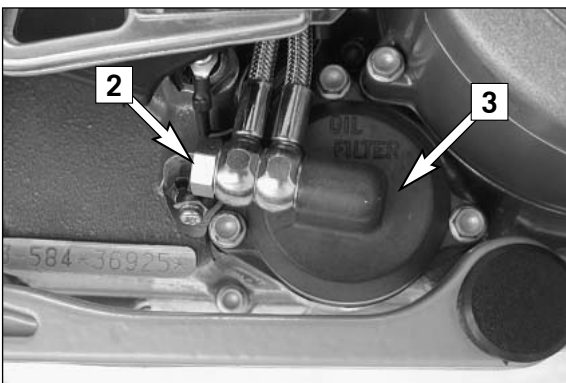

## Changing oil filter \*

Replace the oil filter when changing the engine oil. Press the foot brake pedal and place a screwdriver or similar between foot brake pedal and stopper roll so that the oil filter cover is more accessible. Remove banjo bolt [2] (WS10) and the three screws. Remove oil filter cover [3] and oil filter. Clean the filter case, oil filter cover and sealing areas. Make sure the oil duct in the oil filter cover is not clogged.

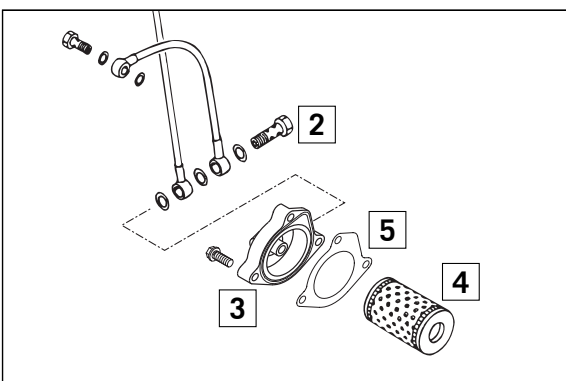

Place the new oil filter [4] on the connection in the oil filter cover and mount together with a new seal [5]. Tighten the 3 screws in the filter cover to 5 Nm. Tighten the hollow screw with seals and tighten to 15 Nm. Finally, start the engine and check the oil system for leakage.

# TROUBLE SHOOTING »

If you let the specified maintenance work on your motorcycle be carried out, disturbances can hardly be expected. Should an error occur nevertheless, we advise you to use the trouble shooting chart in order to find the cause of error. We would like to point out that many operations cannot be performed by oneself. In case of uncertainty, please contact a KTM-dealer.

TROUBLE	CAUSE	REMEDY
Engine doesn't crank. (E.-starter)	Operating error	Turn on the ignition
	Discharged battery.	Recharge the battery and investigate the causes for discharging; contact a KTM dealer
	Defect ignition lock or emergency OFF switch	Check ignition lock and emergency OFF switch, contact a KTM dealer
	Blown fuse safe-starting system.	SXC: Replace fuse (3) SMC: Replace fuse (2)
Engine cranks but doesn't start.	Blown main fuse.	Remove seat and replace the main fuse. If fuse blows again contact a KTM dealer
	Operating error	Open fuel tap, tank fuel, you did not use choke i.e. the warmstart device. Pay attention to starting off information (see driving instructions)
	The motorcycle has been out of operation for a longer period of time. Therefore old fuel has accumulated in the float chamber	The easily inflammable components of the new fuels evaporate during longer periods of standstill. When the motorcycle has been out of operation for more than a week, it is therefore recommended to drain the old fuel from the float chamber. The engine will immediately start off when the float chamber is filled with new fuel.
	Fuel supply interrupted	Place a vessel underneath, remove the drain plug from the carburetor and open the fuel cock, – if fuel leaks out, the carburetor might need cleaning – if no fuel leaks out, check tank ventilation, i.e. clean fuel tap
	Flooded engine	Fully open the throttle when starting or exchange the spark plug, respectively
	Sooty or wet spark plug	Clean and dry the spark plug or exchange it, respectively
	Electrode gap too large	Adjust spark plug elektrode gap to 0,9 mm
	Spark plug connector or spark plug faulty	Dismount spark plug, connect ignition cable, hold to ground (blank place on engine) and actuate starter, a strong spark must be produced at the spark plug – If no spark is created exchange the spark plug. – If the new spark plug doesn't produce a spark either, disconnect the spark plug connector from the ignition cable, hold it a distance of approx. 5 mm from ground and start. – If a spark now occurs, replace spark plug cap – If no spark is produced, control ignition system
Engine fails to idle	The plug connection of the CDI-unit, the pulse generator or the ignition coil has oxydized	Remove the seat, the right side cover and the fuel tank. Clean the plug connection and treat it with contact spray
	Water in carburetor or jets blocked	Dismount and clean carburetor
Engine fails to idle	Glogged idling jet	Disassemble carburetor and clean jets
	Oncorrect adjustment of adjusting screws on carburetor	Have carburetor adjusted
	Defective spark plug	Replace spark plug
	Defective ignition system	Have ignition system checked



# TROUBLE SHOOTING »

TROUBLE	CAUSE	REMEDY
Engine does not rev high	Carburetor fuel level too high because Float needle is dirty or worn out Float leaks Loose carburetor jets Electronic ignition timing faulty	Dismount carburetor and check if worn out Replace float needle Replace float Tighten jets Have ignition system checked
Engine will not reach full power	Fuel supply partially interrupted or carburetor dirty Float leaks Air filter very dirty Valve clearance too small Loss of compression because hand decompressor has no play Electronic ignition timing faulty	Clean and check fuel system as well as carburetor Replace the float Clean or replace air filter, contact a KTM dealer Have valve clearance adjusted Check setting of the hand decompression cable Have ignition system checked
Engine overheats	Insufficient cooling liquid Radiator fins are extremely dirty Foam forms in cooling system Bent radiator hose Thermostat defective Blown fan fuse (SMC) Defect thermostitch (SMC) Fan defective (SMC)	Refill cooling liquid (see maintenance work), check cooling system for leaks Clean radiator with water jet Replace cooling liquid, use antifreezer with brand name Shorten or replace cooling hose Remove and check thermostat (opening temperature 70°C (158°F) or replace it, contact a KTM dealer Replace fuse and check if fan operates properly (see below) Contact a KTM dealer Check if fan operates properly. To do this, start the engine, then bypass the connections to the thermostitch (bottom right radiator), contact a KTM dealer
High oil consumption	Buckling gear ventilation hose Engine oil level too high Engine oil too thin (viscosity)	Readjust or replace ventilation hose Check engine oil level when the engine is warm; correct if necessary Use thicker engine oil; see chapter „Engine oil“
Headlight and parking light fail	Blown fuse	SXC: Replace fuse (5) SMC: Replace fuse (4)
Flasher lights, brake light and horn fail	Blown fuse	SXC: Replace fuse (4) SMC: Replace fuse (3)
The battery is discharged	The ignition (power consumer) hasn't been switched off The battery isn't charged by the generator because	Recharge the battery according to the relevant instructions. Remove seat and check voltage regulator connections; voltage regulator and generator should be checked by a KTM dealer.

## CLEANING »

Clean your motorcycle regularly in order to maintain the beauty of its plastic surfaces. The best manner would be to use warm water that has been mixed with a normal trade washing detergent and a sponge. The hard dirt can be removed before with the help of a soft water jet.

### ! CAUTION

**Never clean your motorcycle with a high-pressured cleaner or a high-pressured water jet. The water could otherwise run into the electrical components, connectors, sheathed cables, bearings, carburetor etc. and cause disturbances or lead to a premature destruction of these parts.**

- You should use normal trade-mark detergents to clean the engine. Strongly dirtied parts should be cleaned additionally with the help of a paint brush.
- After the motorcycle has been rinsed with a soft water jet, it should be dried by air pressure and a cloth. Then take a short drive until the engine has reached the working temperature and also use the brakes. Due to the heat, the water also evaporates at the unapproachable parts of the engine and the brakes.
- Slide back the protective covers on the handlebar-mounted instruments so that any water that may have seeped into this part of the motorcycle is allowed to evaporate.
- After the motorcycle has cooled down, oil and grease all sliding and pivot points. Treat the chain with a chain spray too.
- To prevent failures in the electric system, you should treat the ignition lock, the emergency OFF switch, light switch and the socket connectors with contact spray.

## CONSERVATION FOR WINTER OPERATION »

In the event that the motorcycle is also used in winter and on roads where one has to expect salt spraying, you will have to take precautions against the aggressive road salt.

- clean motorcycle thoroughly and let it dry
- treat engine, carburetor, swing arm, and all other bare or galvanized parts (except for brake discs) with a wax-based anti-corrosion agent.

### ⚠ WARNING

**Keep anti-corrosion agent from getting into contact with the brake discs, for otherwise this will significantly reduce the braking power.**

### ! CAUTION

**After rides on salted roads, clean motorcycle thoroughly with cold water and let it dry well!**

## STORAGE »

Should you desire to make a pause over a longer space of time, please observe the following instructions:

- Clean motorcycle thoroughly (see chapter: CLEANING)
- Change engine oil, oil filter and microfilter (old engine oil contains aggressive contaminations).
- Check antifreezer and amount of cooling liquid.
- Warm up the engine once again, close the fuel cock and wait until the engine dies. Then open the drain plug of the float chamber to remove the remaining fuel.
- Remove spark plug and fill in approx. 5 ccm of engine oil into the cylinder through the opening. Actuate kick-starter 10 times in order to distribute the oil onto the cylinder walls and mount the spark plug.
- Set piston to compression so that the valves will be closed (slowly operate the kickstarter, until you can hear the automatic decompressor click (release))
- Let fuel flow out of tank into an appropriate container.
- Correct tire pressure.
- Lubricate pivot points of the control levers, foot rests, etc. as well as the chain.
- Service the shock absorber linkage
- Disassemble and charge battery (see chapter: BATTERY).
- The storage place should be dry and not subject to excessive temperature fluctuations.
- Cover the motorcycle with an air permeated tarpaulin or blanket. Do not use non air permeable materials as a possible humidity might not be able to escape and could cause corrosion.

### ! CAUTION

**It would be very bad to let the engine run for a short time during the storage period. The engine would not get warmed up enough and the thus developed steam would condense during the combustion process and cause the valves and exhaust to rust.**

### RE-INITIATION AFTER TIME OF STORAGE

- Mount the charged battery (pay attention to polarity) and set the clock.
- Fill up tank with fresh fuel.
- Check motorcycle as before each start (see driving instructions).
- Take a short, careful test ride first.

NOTE: Before you put your motorcycle away for the winter, you have to check all parts for their function and wear. Should any service jobs, repairs, or any refitting be necessary, you should have them carried out during the off-season (lower workload at mechanics' shops). This way, you can avoid the long waiting times at your mechanic at the beginning of the next biking season.

# TECHNICAL SPECIFICATIONS – ENGINE »

ENGINE	625 SXC / SMC
Design	Liquid-cooled single cylinder 4-stroke engine with balancer shaft
Displacement	625 cm <sup>3</sup>
Bore / Stroke	101 / 78 mm (3.97 / 3.07 in)
Ratio	11.7 : 1
Fuel	unleaded fuel with at least RON 95 (USA = Premium RON 91)
Valve timing	4 valves over rocker arm and 1 overhead camshaft, camshaft drive through single chain
Camshaft	249/1
Valve diameter	Intake: 36 mm (1.41 in) Exhaust: 32 mm (1.26)
Valve clearance cold	Intake: 0.12 - 0.15 mm Exhaust: 0.12 - 0.15 mm
Crank shaft bearing	2 cylinder roller bearing
Connecting rod bearing	needle bearing
Top end bearing	bronze bushing
Piston	forged aluminium alloy
Piston rings	1 compression ring, 1 taper face ring, 1 oil scraper ring
Engine lubrication	two Eaton-oilpumps
Engine oil	see table #
Engine oil quantity	appr. 2.1 liters including frame
Primary ratio	straight geared spur wheels 31 : 79 teeth
Clutch	multi disc clutch in oil bath
Transmission	5-speed claw shifted
Gear ratio	1 <sup>st</sup> 14:35 2 <sup>nd</sup> 15:24 3 <sup>rd</sup> 18:21 4 <sup>th</sup> 20:19 5 <sup>th</sup> 22:18
Ignition system	contactless DC-CDI ignition with digital advanced system type KOKUSAN
Ignition timing	adjustment to max. 38° BTDC at 6000 rpm
Generator	12V 200W
Spark plug	NGK DCPR 8E
Spark plug gap	0.9 mm
Cooling system	liquid cooled, permanent rotation of cooling liquid through mechanic driven water pump
Cooling liquid	1 liter, 50% antifreeze, 50% distilled water, at least -25°C (-13°F)
Starting equipment	kick - electric starter

## #

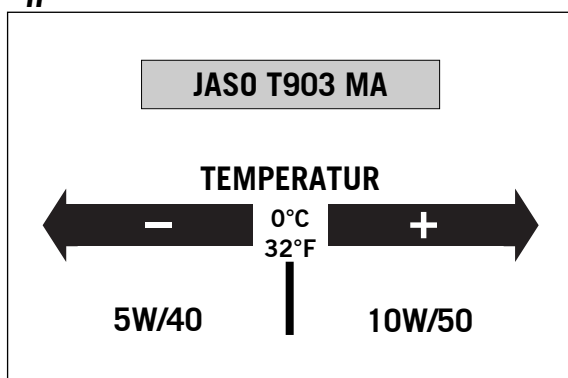

### Engine oil

Only use fully synthetic engine oils that meet the JASO MA quality requirements (see information on the can). KTM recommends Motorex Power Synt 4T in the 10W/50 viscosity (for temperatures over 0°C, 32°F) or 5W/40 (for temperatures under 0°C, 32°F).

**! CAUTION**  
Poor oil quality or minor quantity cause early engine-wear.

## TECHNICAL SPECIFICATIONS – ENGINE »

BASIC CARBURETOR SETTING	
	625 SXC/SMC
Type	Keihin FCR-MX 4138A
Carburator-setting number	4138A
Main jet	165
Jet needle	OBDVT (OBEKR)
Idling jet	42 (45)
Main air jet	200
Idling air jet	100
Needle position	5 <sup>th</sup> from top (4 <sup>th</sup> from top)
Starting jet	85
Mixture control screw open	2
Slide	15
Performance restrictor	slide stop
Stop pump membrane	858 / 2.15 mm
Hot start device	3.8 mm

# TECHNICAL SPECIFICATIONS - CHASSIS »

	625 SXC	625 SMC
Frame	Central chrome-moly-steel frame	
Fork	WP Suspension 4357 MXMA	WP Suspension 4860 MXMA
Wheel travel front/rear	295 / 300 mm (11.6 / 11.8 in)	265 / 300 mm
Rear suspension	Central shock absorber (WP BAVP4681) with PRO-LEVER linkage to rear- swing-arm with needle bearing	
Front brake	Brake caliper floated	4 piston brake caliper
Front brake disc	Disc brake with carbon-steel brake disc Ø 260 mm	Disc brake with carbon-steel brake disc Ø 320 mm
Rear brake	Disc brake with carbon-steel brake disc B 220 mm (8.8 in), brake caliper floated	
Tyres front	90/90-21	120/70-17
Air press. offroad / SM	1.0 - 1.5 bar	1.0 - 1.5 bar
Air press. road	2.0 bar	2.0 bar
Tyres rear	140/80-18	160/60-17
Air press offroad / SM	1.0 - 1.5 bar	1,6 bar
Air press. road	2.0 - 2.2 bar	2.2 - 2.4 bar
Fuel tank capacity	9.2 liter (2.4 US gallons), 2.5 liter (0.5 US gallons) reserve	
Final drive ratio	17:40	16:38
Chain	5/8 x 1/4" X-Ring	
Headlight	12V 35/35 W (Socket P43t)	12V 35/35 W (Socket P43t)
Parking light	12V 5W (Socket W2,1x9,5d)	12V 5W (Socket W2,1x9,5d)
Indicator lamps	12V 1,2W (Socket W2x4,6d)	12V 1,2W (Socket W2x4,6d)
Brake light	12V 21/5W (Socket BaY15d)	12V 21W (Socket Ba15s)
Rear light	12V 21/5W (Socket BaY15d)	12V 5W (Socket W2,1x9,5d)
Flasher light	12V 10W (Socket Ba15s)	12V 10W (Socket Ba15s)
License plate illumination	12V 5W (Socket W2,1x9,5d)	12V 5W (Socket W2,1x9,5d)
Battery	maintenance-free battery 12V 8,6 Ah	
Steering angle	62.5°	63°
Wheel base	1510 ± 10 mm (59.4 ± 0.4 in)	1510 ± 10 mm
Seat high	940 mm (37.0 in)	910 mm
Ground clearance	330 mm (12.9 in)	290 mm
Dead weight without fuel	139 kg (306.4 lbs)	

STANDARD ADJUSTMENT - FORK		
	625 SXC 05187B01	625 SMC 14187B07
Compression adjuster	20	23
Rebound adjuster	12	19
Spring	4,2 N/mm	4,4 N/mm
Spring preload	5 mm	28 mm
Air chamber length	140 mm	110 mm
Fork oil	SAE 5	SAE 5

STANDARD-ADJUSTMENT-SHOCK ABSORBER		
	625 SXC 01187B01	625 SMC 01187B02
Compression adjuster	3	4
Rebound adjuster	5	8
Spring	63 / 260	70 / 260
Spring preload	23 mm	20 mm



## TECHNICAL SPECIFICATIONS - CHASSIS »

TIGHTENING TORQUES - CHASSIS		
Collar nut front axle SXC	M16x1,5	40 Nm
Collar nut front axle SMC	M24x1,5	40 Nm
Collar nut rear axle	M20x1.5	80 Nm
Shock absorber top	M10 (10.9)	45 Nm
Shock absorber bottom	M10 (10.9)	45 Nm
Collar screws brake disk rear	M6 (10.9)	Loctite 243 + 14 Nm
Collar screws brake disk front	M6 (10.9)	Loctite 243 + 14 Nm
Screw brake caliper front	M8	Loctite 243 + 25 Nm
Allan head screw brake caliper front SMC	M10	Loctite 243 + 40 Nm
Bearing bolt linkage arm/frame	M12	60 Nm
Collar nuts rocker arm bolts	M14x1.75	100 Nm
Engine mounting screw	M10	45 Nm
Ball joint for push rod	M8	Loctite 243 + 25 Nm
Sprocket screws on nuts	M8	Loctite 243 + 35 Nm
Collar nut swingarm bolt	M14x1.5	100 Nm
Clamping screws top triple clamp	M8	20 Nm
Clamping screws bottom triple clamp	M8	15 Nm
Clamping screws fork stubs	M8	15 Nm
Screws handlebar clamp	M8	20 Nm
Allan head screw handle bar support	M10	Loctite 243 + 40 Nm
Spoke nipple	M4,5	5 Nm
Other screws / collar nuts on chassis	M6 M8 M10	10 Nm / 15 Nm 25 Nm / 30 Nm 45 Nm / 50 Nm

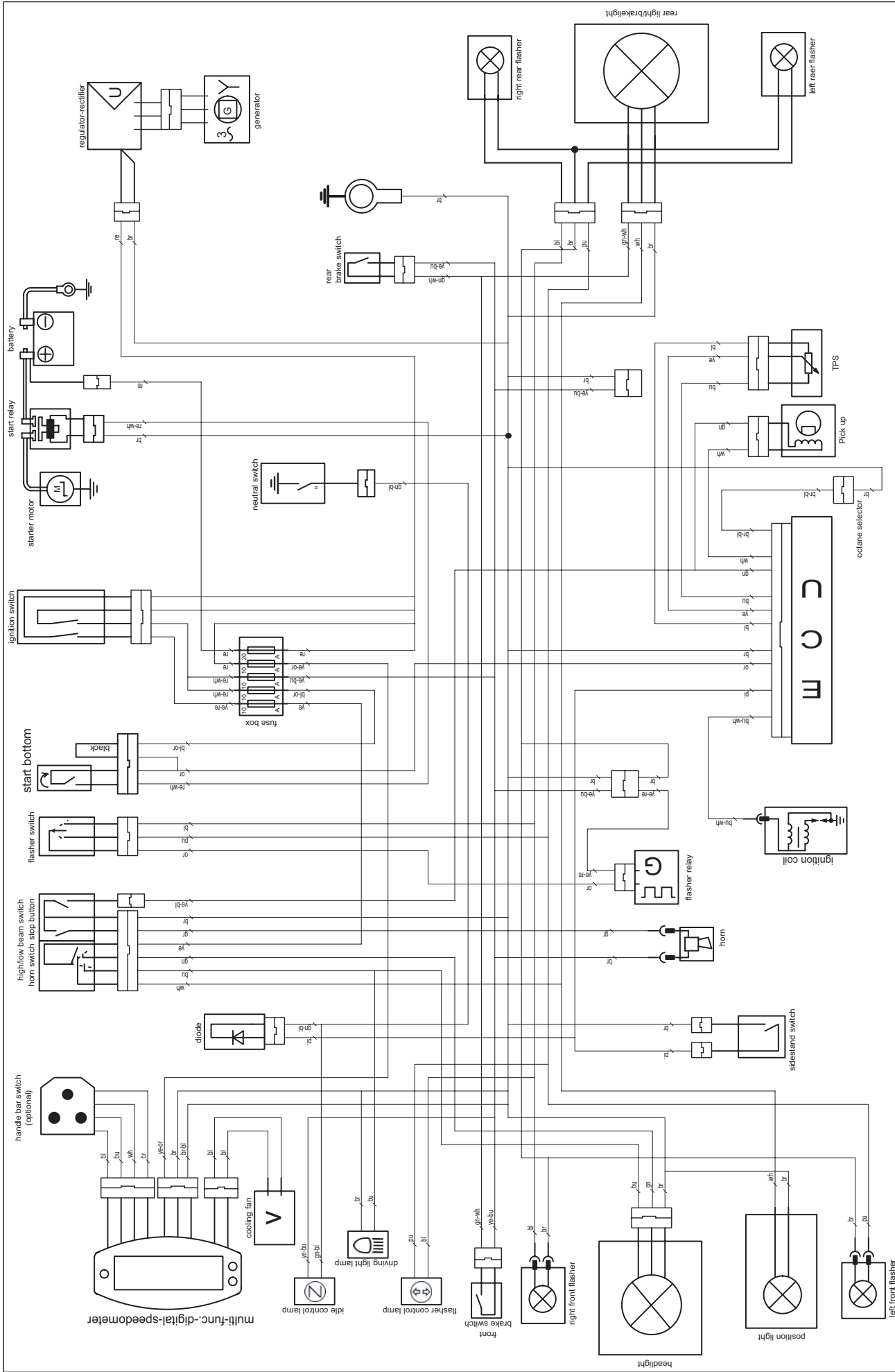

	Page		Page
Accessories and payload	.16	Exchanging the brake light and tail light bulb (SMC)	.39
Activating and deactivating display modes	.8	Exchanging the brake light and tail light bulb (SXC)	.39
Activating the ignition curve for low-octane fuel	.45	Exhaust system (SXC)	.42
Adjusting of free travel at the hand brake lever (SXC)	.29	Filler cap	.12
Adjusting the mixture control screw	.46	Flasher switch	.12
Adjusting the throttle cable	.43	Foot brake pedal	.14
Auspuffanlage (SMC)	.42	Fuel	.20
Battery (SXC)	.37	Fuel tap	.13
Battery for digital speedometer	.36	Fuses	.38
Bleeding of the hydraulic clutch	.44	General information about KTM disc brakes	.29
Braking	.19	General tips and warnings for starting the motorcycle	.16
Breather plug front fork	.25	Hand brake lever (SMC)	.6
Carburetor – Adjust idling	.45	Hand brake lever (SXC)	.6
Chain maintenance	.28	Hand decompression lever	.6
Chain wear	.28	Handlebar lock	.14
Changing oil filter	.48	Head word Index	.56
Changing the basic position of the brake pedal	.33	Hot start device	.13
Changing the basic position of the handbrake lever (SMC)	.29	How to change the handlebar position	.25
Changing the original position of the clutch lever	.44	Ignition lock	.12
Changing the spring preloading of the shock absorber	.26	Indicator lamps	.6
Charging the battery	.37	Instructions for initial operation	.16
Chassis number	.5	Kickstart instructions	.18
Check and adjust steering head bearing	.24	Kickstarter	.13
Check the following before each start	.17	Kilometers or miles	.10
Check the rear brake fluid level	.32	Lubricate rear suspension linkage	.26
Check/set distance of the magnetic sensor	.36	Maintenance work on chassis and engine	.23
Checking chain tension	.27	Oil and screen filter change, bleeding of the oil system	.47
Checking of brake fluid level - front brake	.30	Oil circuit	.47
Checking rubber ring on the WP rear shock absorber	.26	Operation instruments	.6
Checking spoke tension	.36	Overview of the electronic speedometer functions	.11
Checking the adjustment of the hand decompression cable	.43	Periodic maintenance schedule	.21
Checking the coolant level	.40	Rebound damping of fork	.15
Checking the engine oil level	.46	Rebound damping of shock absorber	.15
Checking the float level (float height)	.46	Refilling the front brake fluid reservoir	.30
Checking the front brake pads (SMC)	.31	Refilling the rear brake fluid reservoir	.32
Checking the front brake pads (SXC)	.31	Reinitiation after time of storage	.51
Checking the oil level of the hydraulic clutch	.44	Removal of seat (SMC)	.24
Checking the rear brake pads	.33	Removal of seat (SXC)	.23
Checking the shock absorption rubbers in the rear hub (SMC)	.35	Replacing front brake pads (SXC)	.31
Choke	.13	Replacing headlight lamp/parking light lamp	.38
Cleaning	.51	Replacing the front brake pads (SMC)	.32
Cleaning of air filter	.41	Replacing the rear brake pads	.33
Cleaning the air filter (SXC)	.41	Running in the LC4 models	.16
Cleaning the dust sleeves of the telescopic fork	.25	Serial number locations	.5
Clutch lever	.6	Setting the clock	.11
Combination switch	.12	Shift lever	.13
Compression damping of fork	.15	Shifting/Riding	.19
Compression damping of shock absorber	.15	Starting off	.18
Conservation for winter operation	.51	Starting when the engine is cold	.18
Cooling system	.40	Starting when the engine is warm or hot	.18
Correct chain tension	.27	Stopping and parking	.19
Dismounting and mounting the front wheel (SMC)	.34	Storage	.51
Dismounting and mounting the front wheel (SXC)	.34	Technical specifications – chassis	.54
Dismounting and mounting the rear wheel	.35	Technical specifications – engine	.52
Draining the float chamber of the carburetor	.45	Tires, air pressure	.36
Driving instructions	.17	Tool set (SMC)	.24
Electronic speedometer	.7	Tool set (SXC)	.23
Emergency OFF button	.12	TROUBLE SHOOTING	.49
Engine number, engine type	.5	What to do when the engine is “flooded”	.18
Engine oil	.46	Wiring diagram	.appendix

# SCHALTPLAN » WIRING DIAGRAM











	<p>625 SXC 2005-07</p>	<p>wiring diagram</p>	<p>main harness - 583.11.375.750</p>	<p>20.07.2006</p>
---	------------------------	-----------------------	--------------------------------------	-------------------



ignition switch

cable switch	gn	or	bu	re- wh
cable harness	re	ye- re	re	re- wh
ON 				
light				
OFF				



light switch  
high/low beam switch

cable color	bu	ye	gn	wh
LIGHT OFF				
P.LIGHT 				
LO 				
HI 				
P.LIGHT 				

start switch

cable harness	or	bl- or
cable switch		bl- bl
START 		
unpushed		





horn switch

cable color	re	br
HORN 		
OFF		

kill switch

cable color	ye- bl	br
pushed		
unpushed		

flasher switch

cable harness	or	pu	bl
TURN L 			
TURN R 			
OFF			

brake switch

cable harness	gn- wh	ye- bu
cable switch	bl	bl
pushed		
unpushed		

sidestand switch

cable harness	br	pi
cable switch	bl	bl
folded up		
folded down		

# SCHALTPLAN » WIRING DIAGRAMM

ENGLISH	DEUTSCH	ITALIANO
headlight	Scheinwerfer	faro
parking light	Standlicht	luce di posizione
turn indic left fr	Blinker li vo	lampegg ant sn
turn indic left fr	Blinker re vo	lampegg ant dx
ignition controll ON	Zündungskontrolle ON	spiedicontrollo ON
high beam indicator	Fernlichtkontrolle	spia abbagliante
turn indicator	Blinkerkontrolle	spia lampeggiatori
multip cont plug (2)	2-Pol Stecker	connettore a 2 poli
multip cont plug (3)	3-Pol Stecker	connettore a 3 poli
multip cont plug (4)	4-Pol Stecker	connettore a 4 poli
stoplight switch f	Bremslichtsch vo	int luce arresto ant
stoplight switch r	Bremslichtsch vo	int luce arresto post
horn	Horn	clacson
turn indicator	Blinkgeber	trasmitt di lampeg
CDI	CDI	CDI
spark plug	Zündkerze	candela
ignition coil	Zündspule	bobina d'accens
generator	Genrator	dinamo
pulser coil	Impulsgeber	trasmettitore d imp
regulator-rectifier	Regelgleichrichter	regol di tens
TPS	TPS	TPS
blink switch	Blinkerschalter	int lampeggiatori
combinat switch	Kombischalter	multicomando
blinker left rear	Blinker li hi	lampegg post sn
blinker right rear	blinker re hi	lampegg post dx
rear-stoplight	Brems-Schlusslicht	fanal post di freno
fan connection	Lüfteranschluss	connet ventilatore
licence pl lightning	Kennzeichenbel.	iluminat de targa
fusebox	Sicherungskasten	scatola fusibili
capacitor	Kondensator	condensatore
ground connection	Masseanschluss	collegam di masse
multip cont plug (6)	6-pol stecker	connettore a 6 poli
sensorcable	Sensorkabel	cavo sensor
battery 12V	Batterie 12V	batteria 12V
ignition switch	Zündschloss	interruttore accesion
starter relay	Startrelaise	rele d avviamento
starter engine	Startermotor	mot d avviamento ele
run-off/start switch	Start-Not-Aus	disinsertor/partire

CABLE COLOURS	KABELFARBEN	CAVO COLORATO
bl: black	bl: schwarz	bl: nero
ye: yellow	ye: gelb	ye: giallo
bu: blue	bu: blau	bu: blu
gn: green	gn: grün	gn: verde
re: red	re: rot	re: rosso
wh: white	wh: weiß	wh: bianco
br: brown	br: braun	br: marrone
or: orange	or: orange	or: arancione
pi: pink	pi: rosa	pi: rosa
gr: grey	gr: grau	gr: grigio
pu: purple	pu: violett	pu: violetto



ENGLISH

headlight  
 parking light  
 turn indic left fr  
 turn indic left fr  
 ignition controll ON  
 high beam indicator  
 turn indicator  
 multip cont plug (2)  
 multip cont plug (3)  
 multip cont plug (4)  
 stoplight switch f  
 stoplight switch r  
 horn  
 turn indicator  
 CDI  
 spark plug  
 ignition coil  
 generator  
 pulser coil  
 regulator-rectifier  
 TPS  
 blink switch  
 combinat switch  
 blinker left rear  
 blinker right rear  
 rear-stoplight  
 fan connection  
 licence pl lightning  
 fusebox  
 capacitor  
 ground connection  
 multip cont plug (6)  
 sensor cable  
 battery 12V  
 ignition switch  
 starter relay  
 starter engine  
 run-off/start switch

FRANCAIS

phare  
 feu de position  
 clignoteur av gauche  
 clignoteur av droit  
 temion ON  
 temoin feu route  
 temoin de clignoteur  
 connect multiple (2)  
 connect multiple (3)  
 connect multiple (4)  
 contact de stop av  
 contact Harr de stop  
 klaxon  
 centrale clignot  
 CDI  
 bougie  
 bobine d'allumage  
 gnerateur  
 capteur  
 regulat redresseur  
 TPS  
 contact d clignoteur  
 commodo  
 clign arr gauche  
 clign arr droite  
 feu arr et de stop  
 connect ventilateur  
 ecl plaque d immat  
 boite a fusibles  
 condensateur  
 masse  
 connect multiple (6)  
 capteur cable  
 batterie 12V  
 contact d allum  
 relaise de demarreur  
 demarreur electrique  
 bout de demar/arr d urg

ESPANIOL

faro  
 luz de posicion  
 interm izquierdo delantero  
 intermitene derecho delantero  
 luces de aviso ON  
 lampara aviso luces largas  
 lampara aviso intermitentes  
 conector multiple 2  
 conector multiple 3  
 conector multiple 4  
 interr luz de freno del  
 interr luz de fren tras  
 claxon  
 conjunto del intermintente  
 CDI  
 bujia  
 bobina de encendido  
 generador  
 generado de impusos  
 regulador de tension  
 TPS  
 interruptor clingoteur  
 interruptor combinado  
 intermitente izquierdo trasero  
 intermitente derecho trasero  
 luz de freno trasero  
 conector ventilador  
 luz lpaca de matricula  
 caja de fusibles  
 condensador  
 conector de massa  
 conecotr multiple (6)  
 sensor cable  
 batteria 12V  
 llave de contata  
 rele de arranque  
 motor de arranque  
 boton de arranque per de urg

CABLE COLOURS

bl: black  
 ye: yellow  
 bu: blue  
 gn : green  
 re: red  
 wh: white  
 br: brown  
 or: orange  
 pi: pink  
 gr: grey  
 pu: purple

COULEUR DE CABLE

bl: noir  
 ye: jaune  
 bu: bleu  
 gn: vert  
 re: rouge  
 wh: blanc  
 br: brun  
 or: orange  
 pi: rose  
 gr: gris  
 pu: violet

COLOR DE CABLE

bl: negro  
 ye: amarillo  
 bu: azul  
 gn: verde  
 re: rojo  
 wh: blanco  
 br: marron  
 or: naranja  
 pi: rosado  
 gr: gris  
 pu: violeta



7/2007 FOTO: MITTERBAUER



KTM Group Partner



**KTM-Sportmotorcycle AG**  
A-5230 Mattighofen  
[www.ktm.at](http://www.ktm.at)