

640 DUKE II

BEDIENUNGSANLEITUNG

OWNERS HANDBOOK

2001

KTM
SPORTMOTORCYCLES



Art.Nr. 3.205.99 11/2000

IMPORTANT

WE STRONGLY SUGGEST THAT YOU READ THIS MANUAL CAREFULLY AND COMPLETELY BEFORE GOING ON YOUR FIRST RIDE. IT CONTAINS A GREAT DEAL OF INFORMATION AND ADVICE WHICH WILL HELP YOU USE AND HANDLE YOUR BIKE PROPERLY. IN YOUR OWN INTEREST, PLEASE PAY PARTICULAR ATTENTION TO NOTICES THAT ARE MARKED AS FOLLOWS:

⚠ **WARNING** ⚠

IGNORING THESE INSTRUCTIONS, CAN ENDANGER YOUR BODY AND YOUR LIFE.

! **CAUTION** !

IGNORING THESE INSTRUCTIONS COULD CAUSE DAMAGE TO PARTS OF YOUR MOTORCYCLE OR THAT THE MOTORCYCLE IS NOT ROAD-SAFE ANYMORE.

Please insert the series numbers of your motorcycle in the boxes below

Cassis number

Engine number

Stamp of dealer

CONSUMER INFORMATION FOR AUSTRALIA ONLY

TAMPERING WITH NOISE CONTROL SYSTEM PROHIBITED

Owners are warned that the law may prohibit:

- (a) The removal or rendering inoperative by any person other than for purposes of maintenance, repair or replacement, of any device or element of design incorporated into any new vehicle for the purpose of noise control prior to its sale or delivery to the ultimate purchaser or while it is in use; and
- (b) the use of the vehicle after such device or element of design has been removed or rendered inoperative by any person.

KTM SPORTMOTORCYCLE AG RESERVES THE RIGHT TO MODIFY ANY EQUIPMENT, TECHNICAL SPECIFICATIONS, COLORS, MATERIALS, SERVICES OFFERED AND RENDERED, AND THE LIKE SO AS TO ADAPT THEM TO LOCAL CONDITIONS WITHOUT PREVIOUS ANNOUNCEMENT AND WITHOUT GIVING REASONS, OR TO CANCEL ANY OF THE ABOVE ITEMS WITHOUT SUBSTITUTING THEM WITH OTHERS. IT SHALL BE ACCEPTABLE TO STOP MANUFACTURING A CERTAIN MODEL WITHOUT PREVIOUS ANNOUNCEMENT. IN THE EVENT OF SUCH MODIFICATIONS, PLEASE ASK YOUR LOCAL KTM DEALER FOR INFORMATION. WE SHALL NOT BE HELD LIABLE FOR ANY PRINTING ERRORS.

Introduction

We would like to congratulate you on your purchase of a KTM motorcycle. Let us also take this opportunity to thank you for putting your trust in us; we will not let you down.

You are now owner of a sporty and modern motorcycle which you are bound to have a great time with provided you care for it properly. **Before going for a first ride on your motorbike, you should read this Owner's Handbook carefully, even if this takes some of your precious time, so as to familiarize yourself with how your motorbike is to be operated and which features it offers you. Only by doing so will you learn how you can best tune your motorcycle to your needs and how you can avoid bodily injuries. In addition, this Owner's Handbook contains invaluable information about motorcycle maintenance.** At the time of printing, this User's Guide corresponded to the latest state of this model family. It is, however, possible that we may have made slight modifications in the meantime due to development in our motorcycle design. The Owner's Handbook is an essential part of the motorbike and should - when the bike is sold - be handed over to the new owner.

Many motorcyclists have a good working knowledge of motorcycle mechanics; if this is true in your case, you will be able to use this Owner's Handbook to carry out most of the maintenance steps yourself. If, on the other hand, you are not very familiar with motorcycles, it might be better to have a professional KTM dealer perform those steps marked by * found in the chapter entitled "Maintenance Work on Chassis and Engine" of this manual.

Take special care to follow the recommended run in, inspection, and maintenance intervals. Heeding these guidelines will significantly increase the life of your motorcycle. Be sure to have any maintenance jobs performed by an authorized KTM dealer. Address your special requests to an authorized KTM dealer who, should the need arise, will be supported by the KTM importer.

Please do not forget to don your helmet, eye protection, and protective clothing when going for a ride. KTM riders are responsible riders! We wish you a lot of fun when driving !



KTM Austria's certificate of achievement for its Quality System ISO 9001 is the beginning of an on-going total re-engineering quality plan for a brighter tomorrow.

KTM SPORTMOTORCYCLE AG
5230 MATTIGHOFEN, AUSTRIA

ALL RIGHTS RESERVED TO MAKE ALTERATIONS TO DESIGN AND MODEL.

© by KTM SPORTMOTORCYCLE AG, AUSTRIA All rights reserved

INDEX

	Page		Page
IMPORTANT NOTES1	Checking of brake fluid level - front brake20
SERIAL NUMBER LOCATING4	Refilling the front brake fluid reservoir20
Cassis number4	Checking the front brake pads21
Engine number, engine type4	Changing the basic position of the brake pedal21
OPERATION INSTRUMENTS4	Checking the rear brake fluid level21
Clutch lever4	Refilling the rear brake fluid reservoir21
Hand decompression lever4	Checking the rear brake pads22
Choke lever4	Dismounting and mounting the front wheel22
Hand brake lever5	Dismounting and mounting the rear wheel22
Speedometer5	Checking the damping rubbers in the rear wheel23
Tachometer5	Tires, air pressure24
Indicator lamps5	Battery24
Ignition lock, with 4 switch position6	Charging the battery24
Ignition lock with 3 switch position6	Main fuse25
Combination switch6	Fuses for individual power-consuming units25
Emergency OFF button6	Opening the head light mask25
Emergency OFF switch7	Headlight range adjustment26
Filler cap7	Headlight - replacing the bulbs26
Fuel7	Parking light - replacing the bulb26
Fuel tap7	Flasher - replacing the bulbs26
Shift lever8	Stop light and tail light - replacing bulb27
Kickstarter8	Cooling system27
Foot brake pedal8	Checking the coolant level28
Compression damping of fork8	Adjusting the clutch cable28
Rebound damping of fork8	Checking the setting of the hand decompression cable28
Compression damping of shock absorber9	Adjusting the choke cable28
Rebound damping of shock absorber9	Adjusting idle speed29
Seat lock9	Draining of float chamber of the carburetor29
Supporting strap for the passenger9	Oil circuit29
DRIVING INSTRUCTIONS10	Engine oil30
LUBRICATION AND MAINTENANCE SCHEDULE14	Checking engine oil level30
MAINTENANCE WORK ON CHASSIS AND ENGINE16	Change of oil and fine screen filter, bleeding of the oil system30
Tool kit16	Changing oil filter31
Checking and adjusting the steering head bearing16	Changing the fine screen filter31
Changing the spring preload of the shock absorber17	TROUBLE SHOOTING32
Checking the rubber ring on the shock absorber17	CLEANING35
Lubricate rear shock absorber linkage17	CONSERVATION FOR WINTER OPERATION35
Checking chain tension18	STORAGE35
Correcting chain tension18	Re-initiation after time of storage35
Chain wear18	TECHNICAL SPECIFICATIONS - ENGINE36
Chain maintenance19	TECHNICAL SPECIFICATIONS - CHASSIS37
Maintaining chain tension eccentrics19	HEAD WORD INDEX39
General information about KTM disc brakes19	WIRING DIAGRAMMAPPENDIX
Changing the basic position of the handbrake lever20	CONSUMER INFORMATION FOR USA ONLYAPPENDIX

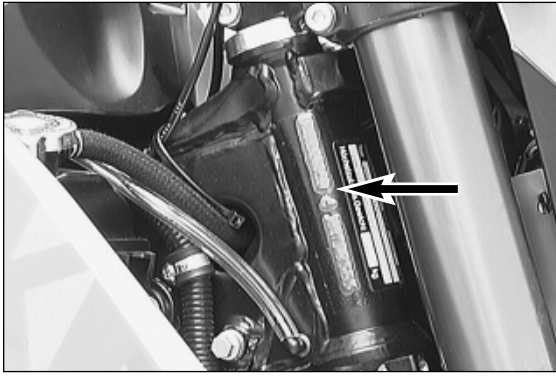

SERIAL NUMBER LOCATIONS

Chassis number

The frame number is stamped on the right side of the steering head tube. Write this number into the relevant box on page 1.

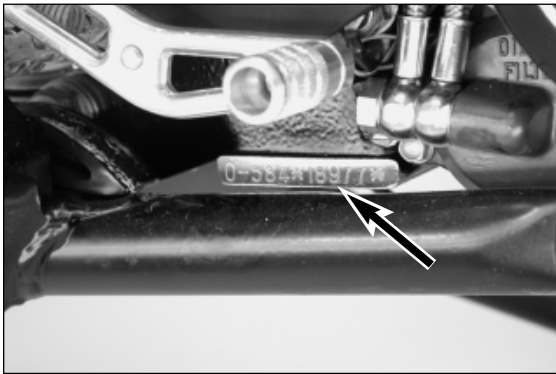

Engine number, engine type

The engine number and engine type are stamped on the right hand side of the engine below the engine sprocket. Write the number into the box on page no 1.

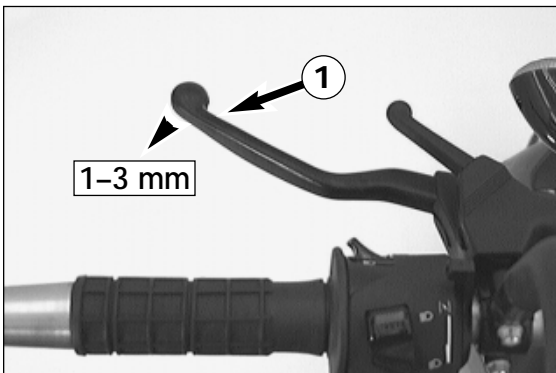

OPERATION INSTRUMENTS

Clutch lever

The clutch lever ① is fitted on the left hand side of the handle bar. When engine is cold, there should be a play of 1-3 mm (0.04-0.1 in) (measured at outer edge).

! CAUTION !

IF THERE IS NO PLAY ON THE CLUTCH LEVER, THE CLUTCH WILL START TO SLIP. THE CLUTCH WILL THEN OVERHEAT, DESTROYING THE CLUTCH LININGS.

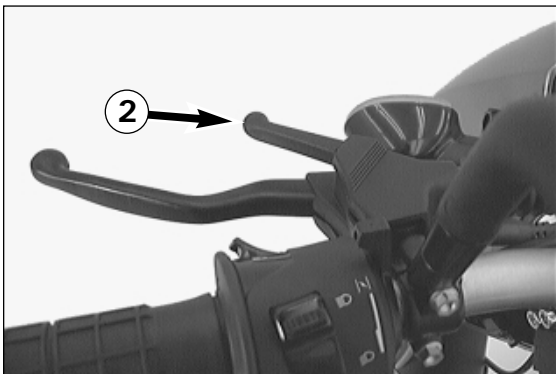

Hand decompression lever

The hand decompression lever ② is only used in two special cases:

- a) When the engine stalled.
It is possible that the starter motor is not able to crank the engine on the next attempt. This is due to the fact that the automatic decompressor doesn't work properly. If this happens, pull the manual decompression lever and start again. Afterwards normal starting will be possible.
- b) When you want to push the motorcycle.
While pushing, pull the hand decompression lever to make it easier to get the engine going.

! CAUTION !

THE SETTING OF THE HAND DECOMPRESSION CABLE SHOULD BE REGULARLY CHECKED (SEE MAINTENANCE WORK). A LACK OF PLAY IN THE HAND DECOMPRESSION LEVER CAN RESULT IN ENGINE DAMAGE.

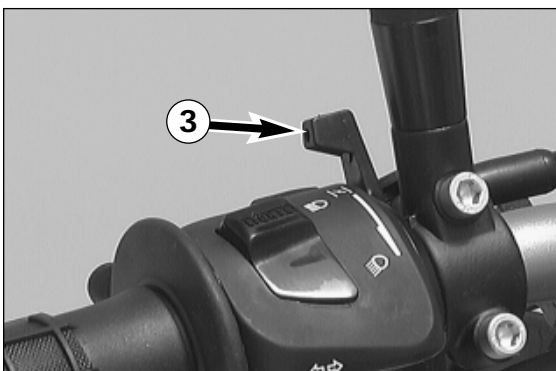

Choke lever

When the choke lever ③ is pulled backwards, a bore is opened in the carburetor which enables the engine to draw in additional fuel. This produces a „rich“ fuel/air mixture necessary for cold start. When the choke lever is pushed forward as far as it will go, the bore will be closed again. In this position the choke cable must have a play of approx. 2 mm.

! CAUTION !

IF THERE IS NO PLAY IN THE CHOKE CABLE, THE BORE OF THE COLD STARTER SYSTEM CANNOT BE COMPLETELY CLOSED. THIS RESULTS IN HIGH FUEL CONSUMPTION, THE ENGINE RUNS UNEVENLY WITH EXTREME WEAR OF PISTON AND CYLINDER.

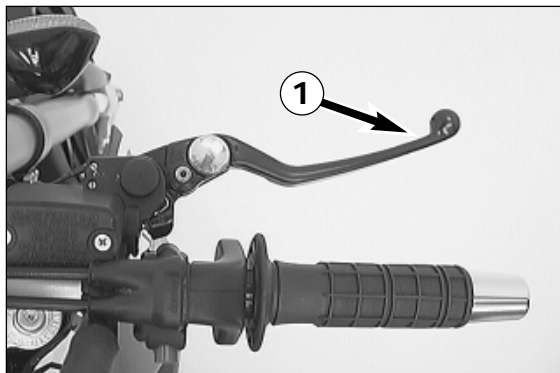

Hand brake lever

The hand brake lever ❶ is mounted on the right side of the handlebar. The basic position of the handbrake lever can be changed in 4 steps (see Maintenance work on chassis and engine).

⚠ **WARNING** ⚠

IF THE RESISTANCE IN THE HAND BRAKE LEVER OR FOOT BRAKE PEDAL FEELS "SPONGY" (NOT ENOUGH RESISTANCE), THIS IS AN INDICATION THAT SOMETHING IS WRONG WITH THE BRAKE SYSTEM. DON'T RIDE YOUR MOTORCYCLE ANYMORE WITHOUT FIRST HAVING THE BRAKE SYSTEM LOOKED OVER BY A KTM DEALER.

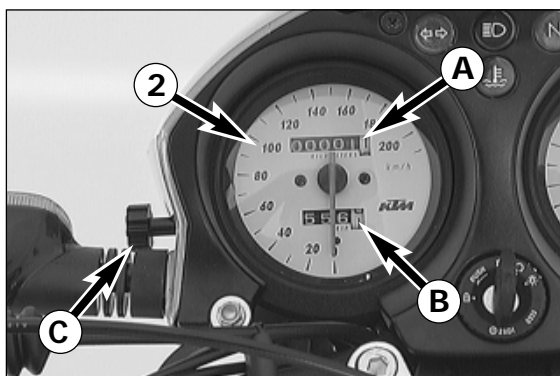

Speedometer

The mileage indicator ❸ in the speedometer ❷ indicates overall mileage. The day mileage indicator ❹ can be set to 0 by means of the setting wheel ❺. Turn the setting wheel forward until only zeros can be seen in the display.

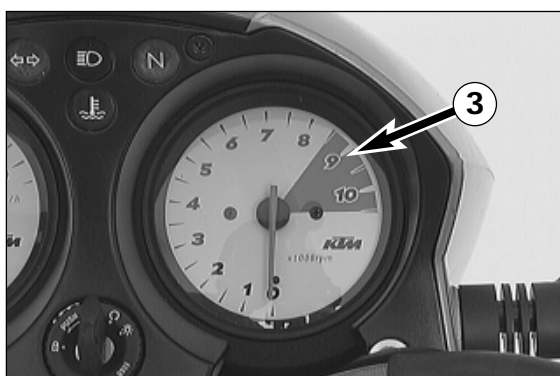

Tachometer

The tachometer ❸ shows the engine speed in revolutions per minute (rpm). Do not push the engine into the orange zone, which begins at 8500 rpm.

! **CAUTION** !

MAXIMUM RECOMMENDED ROTATION RATE IS 8500 RPM. ROTATION RATES EXCEEDING 8500 RPM WILL SHORTEN YOUR ENGINE'S LIFE. REFER ALSO TO THE SECTION ON RUNNING IN YOUR MOTORCYCLE TO BE FOUND IN THE "DRIVING INSTRUCTIONS" CHAPTER.



Indicator lamps

- ❶ The green indicator lamp flashes when the flasher light is working in the same rhythm as the flasher light. Faster flashing of the flasher control lamp indicates a defect bulb
- ❷ The blue indicator lamp lights up when the high beam is on.
- ❸ The green indicator lamp lights up when the neutral gear is selected
- ❹ The red cooling liquid temperature warning lamp lights up as soon as the cooling liquid has reached a temperature of approximately 110° C (230° F).





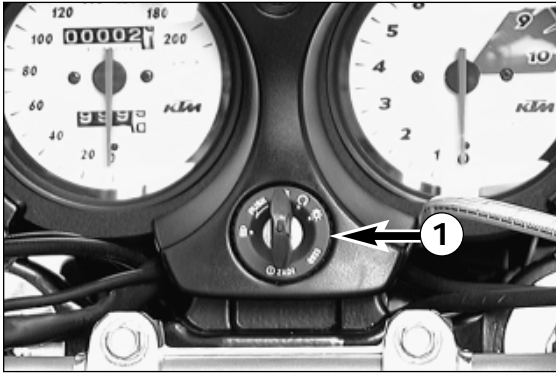

! **CAUTION** !



IF THE RED COOLING LIQUID TEMPERATURE WARNING LAMP LIGHTS UP WHILE YOU ARE DRIVING, THE COOLING SYSTEM IS PROBABLY DEFECT. IMMEDIATELY STOP THE ENGINE AND CHECK THE COOLING LIQUID LEVEL. PLACE A CLOTH ON THE RADIATOR CAP. OPEN THE CAP SLOWLY, SO THE EXCESS PRESSURE IN THE COOLING SYSTEM CAN ESCAPE. CAUTION SCALDING HAZARD! DRIVING WITH THE WARNING LAMP ON WILL CAUSE ENGINE DAMAGE.



Ignition lock with 4 switch positions

Switch positions of ignition lock ❶:



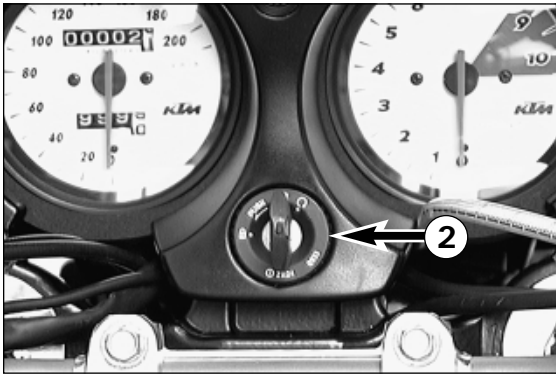

-  Ignition off, light off (engine can't be started)
-  Ignition on, light off (engine can be started)
-  Ignition on, light on (engine can be started)
-  Ignition off, light off, handlebar blocked
To switch the ignition to position  turn the ignition key to position  and firmly press it into the lock. Turn the handlebar all the way to the left, then turn the ignition key to the left.



The ignition key can be withdrawn in position  and .



Ignition lock with 3 switch positions

Switch positions of ignition lock ❷:

-  Ignition off, light off (engine can't be started)
-  Ignition on, light on (engine can be started)
-  Ignition off, light off, handlebar blocked
To switch the ignition to position  turn the ignition key to position  and firmly press it into the lock. Turn the handlebar all the way to the left, then turn the ignition key to the left.

The ignition key can be withdrawn in position  and .

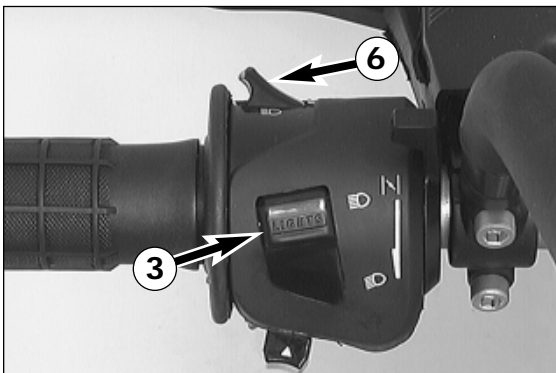



Combination switch

The rocker switch LIGHTS ❸ actuates the high beam or low beam.

 = High-beam light

 = Low-beam light

 The indicator switch ❹ returns to central position after actuation. Press flasher switch towards switch housing to switch off the flasher.

 The horn is sounded with button ❺.

 The light signal (high beam) is actuated with button ❻.

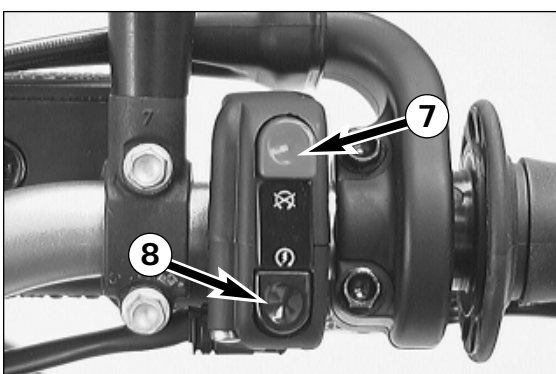
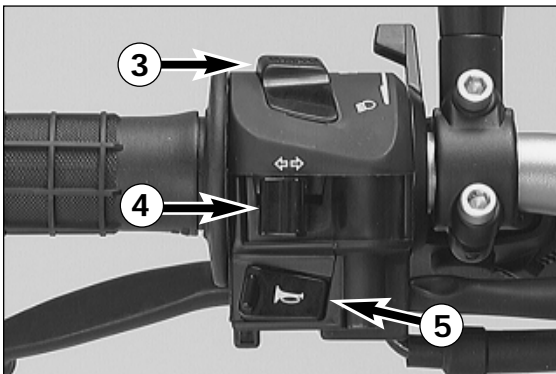

Emergency OFF button

 The red emergency-OFF button ❷ is arranged adjacent to the throttle grip. To turn off the engine, push the button until the engine comes to a standstill.

 Pushing of the black starter button ❸ actuates the E-starter.



WARNING



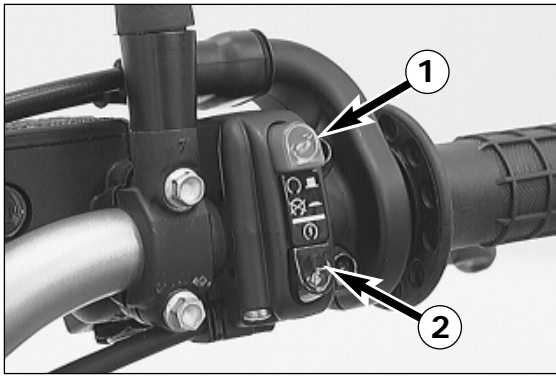

ALWAYS VERIFY THAT THE TRANSMISSION HAS BEEN SET TO IDLE (NEUTRAL) BEFORE ACTUATING THE STARTER BUTTON. IF YOU START THE MOTORCYCLE WITH A GEAR ENGAGED, THE MOTORCYCLE WILL MOVE FORWARD.



Emergency OFF switch

The red emergency-OFF switch ❶ is arranged adjacent to the throttle grip.

- 
 In this position, the E-starter is operational and the engine can be started.
- 
 In this position, the E-starter and ignition circuits are interrupted. The E-starter cannot be actuated, and the engine will not start, not even if you attempt to start it with the kickstarter.
- 
 Pushing of the black starter button ❷ actuates the E-starter.

⚠ WARNING ⚠

ALWAYS VERIFY THAT THE TRANSMISSION HAS BEEN SET TO IDLE (NEUTRAL) BEFORE ACTUATING THE STARTER BUTTON. IF YOU START THE MOTORCYCLE WITH A GEAR ENGAGED, THE MOTORCYCLE WILL MOVE FORWARD.

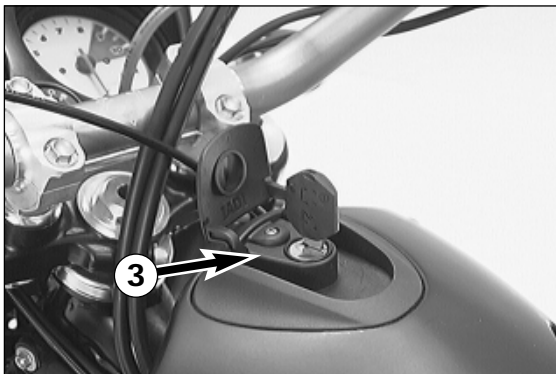

Filler cap

The filler cap ❸ can be locked and is provided with a fuel evaporation control system.

To open the cap insert the ignition key, turn it 90° counterclockwise, then lift off the filler cap.

To close the tank insert the filler cap, turn the ignition key 90° clockwise and take out the key.

Fuel

The LC4 engine needs premium gasoline with an octane number of 95 or higher.

! CAUTION !

USE ONLY UNLEADED PREMIUM GRADE GASOLINE (95 OCTANES). NEVER USE ANY GASOLINE HAVING LESS THAN 95 OCTANES BECAUSE IT MAY DAMAGE THE ENGINE.

⚠ WARNING ⚠

GASOLINE IS HIGHLY FLAMMABLE AND POISONOUS. EXTREME CAUTION SHOULD BE USED WHEN HANDLING GASOLINE. DO NOT REFUEL THE MOTORCYCLE NEAR OPEN FLAMES OR BURNING CIGARETTES. ALWAYS SWITCH OFF THE ENGINE BEFORE REFUELLING. BE CAREFUL NOT TO SPILL GASOLINE ON THE ENGINE OR EXHAUST PIPE WHILE THE ENGINE IS HOT. WIPE UP SPILLS PROMPTLY. IF GASOLINE IS SWALLOWED OR SPLASHED IN THE EYES, SEEK A DOCTOR'S ADVICE IMMEDIATELY.

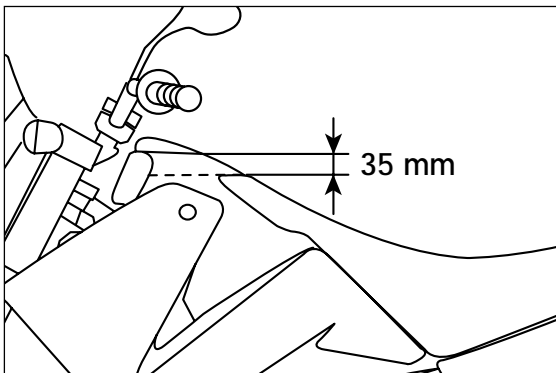

Fuel expands when its temperature rises. Therefore do not fill the tank to the top (see fig.).

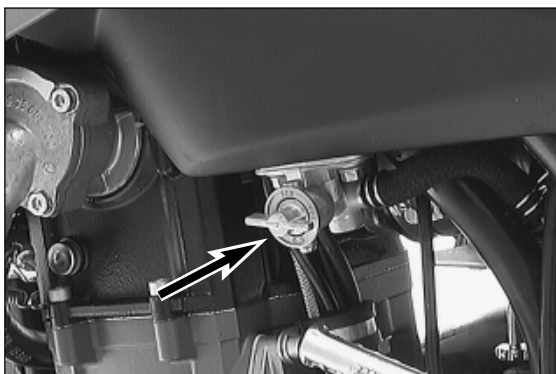

Fuel tap

OFF In this position the fuel tap is closed. No fuel may flow to the carburetor.

ON When using the motorcycle, the twist grip must be set to the ON position. Now fuel may flow to carburetor. In this position the tank empties down to the fuel reserve of approx. 2.5 liters.

RES The reserve, approximately 2.5 liters, cannot be tapped until the twist grip is turned to the RES position. Fill the tank as soon as possible and remember to turn the twist grip back to the ON position so that you will have backup fuel next time, too.

! CAUTION !

THE FUEL TAP SHOULD BE LOCKED WHENEVER THE MOTORCYCLE IS PARKED. IF THE TAP IS NOT CLOSED THE CARBURETOR MAY OVERFLOW AND FUEL CAN GET INTO THE ENGINE.

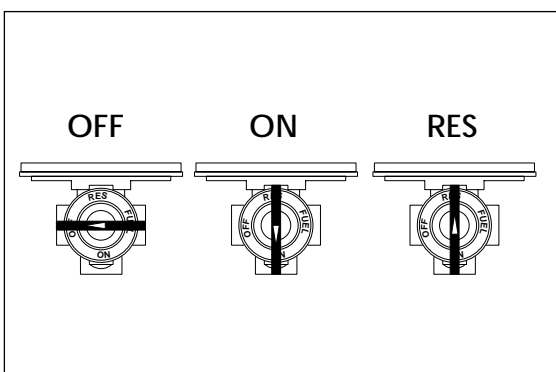

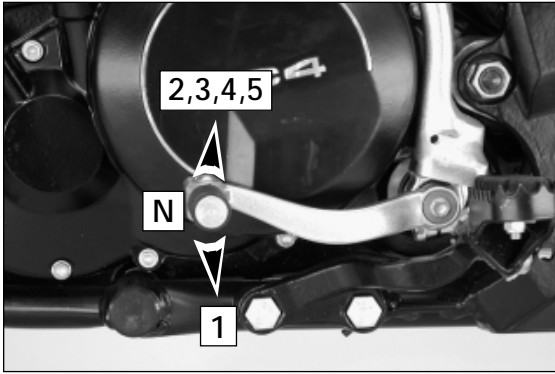

Shift lever

The shift lever is mounted on the left side of the engine. The position of the gears is shown in the illustration. Neutral, or the idle speed, is located between first and second gear.



Kickstarter

The kickstarter is mounted on the left side of the engine. Its upper part can be swivelled.



WARNING



- IF YOU WANT TO START THE ENGINE, MAKE SURE THAT YOU ALWAYS PUT ON STURDY MOTORCYCLE BOOTS IN ORDER TO AVOID INJURIES. YOU MIGHT SLIP OFF THE KICKSTARTER, OR THE ENGINE MAY KICK BACK AND PROPEL YOUR FOOT UPWARD WITH GREAT VEHEMENCE.
- ALWAYS KICK KICKSTARTER BRISKLY ALL THE WAY WITHOUT OPENING THE THROTTLE. KICKING THE KICKSTARTER WITH NOT ENOUGH MOMENTUM, AND AN OPENED THROTTLE GRIP INCREASE THE KICK-BACK HAZARD.

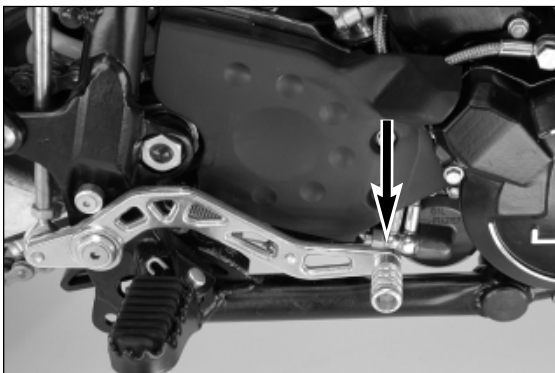

Foot brake pedal

The foot brake pedal is located in front of the right footrest. The basic position can be adjusted to the seat position (see maintenance work).



WARNING



IF THE RESISTANCE IN THE HAND BRAKE LEVER OR FOOT BRAKE PEDAL FEELS "SPONGY" (NOT ENOUGH RESISTANCE), THIS IS AN INDICATION THAT SOMETHING IS WRONG WITH THE BRAKE SYSTEM. DON'T RIDE YOUR MOTORCYCLE ANYMORE WITHOUT FIRST HAVING THE BRAKE SYSTEM LOOKED OVER BY A KTM DEALER.

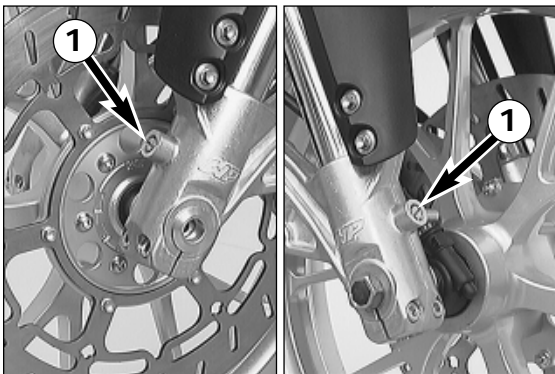

Compression damping of fork

Hydraulic compression damping determines the reaction when the fork is compressed. The degree of compression can be adjusted with adjusting screws at the bottom of the fork legs.

The damping rate of the compression damping mechanism can be readjusted at the adjusting screws ❶ located at the fork leg. Turn it clockwise to increase damping, and counterclockwise to reduce damping during compression.

STANDARD ADJUSTMENT

- turn adjusting screw clockwise as far as it will go
- turn it back by as many clicks as are specified for the relevant type of fork

WP Roma. 14 clicks

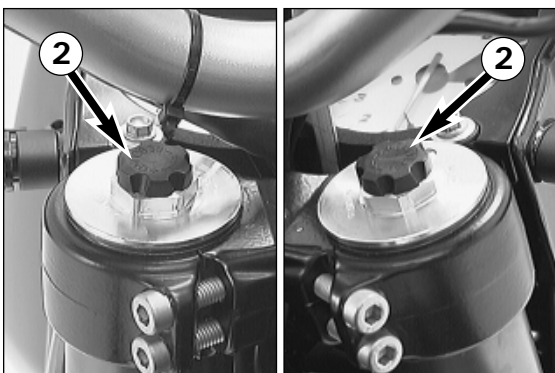

Rebound damping of fork

Hydraulic rebound damping determines the reaction when the fork is rebound. By turning the adjusting screw ❷ (REB), the degree of damping of the rebound can be adjusted. Turn the knob clockwise to increase damping, turn it counterclockwise to reduce damping during rebounding.

STANDARD ADJUSTMENT

- turn adjusting screw clockwise as far as it will go
- turn it back by as many clicks as are specified for the relevant type of fork

WP Roma. 16 clicks

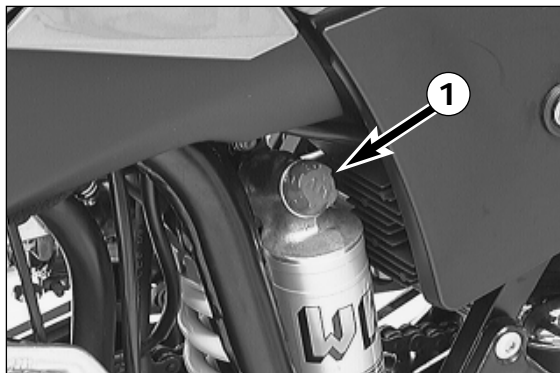

Compression damping of shock absorber

With the knob ❶ the degree of damping of the compression can be adjusted to 7 positions. Turn the knob counterclockwise to increase damping, turn it clockwise to reduce damping during rcompressing.

STANDARD ADJUSTMENT: position 3

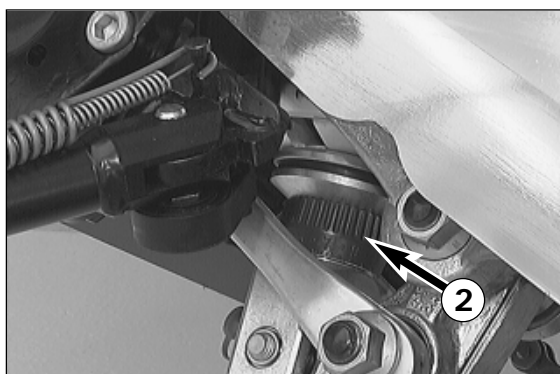

Rebound damping of shock absorber

With the setting wheel ❷ the degree of damping of the rebound can be adjusted to 11 positions. Turn the knob to the left side to increase damping, turn it to the right side to reduce damping during rebounding.

STANDARD ADJUSTMENT: position 5

⚠ **WARNING** ⚠

- NEVER CHANGE DAMPING BETWEEN THE TEST DRIVES MORE THAN 2 CLICKS.
- THE DAMPING UNIT OF THE SHOCK ABSORBER IS FILLED WITH HIGHLY COMPRESSED NITROGEN. NEVER TRY TO TAKE THE SHOCK ABSORBER APART OR TO DO ANY MAINTENANCE WORK YOURSELF. SEVERE INJURIES COULD BE THE RESULT.



Seat lock

The seat is secured by the lock on the side of the seat ❸

REMOVING THE SEAT:

Put the ignition key into the lock. Turn it counter clockwise all the way to the stop to unlock the seat.

Lift the rear portion of the seat, pull it backwards and disengage it from the oval head screw ❹.

The tool set, the battery and the main fuse are located below the seat. Additionally, there is a compartment where small items can be stored.

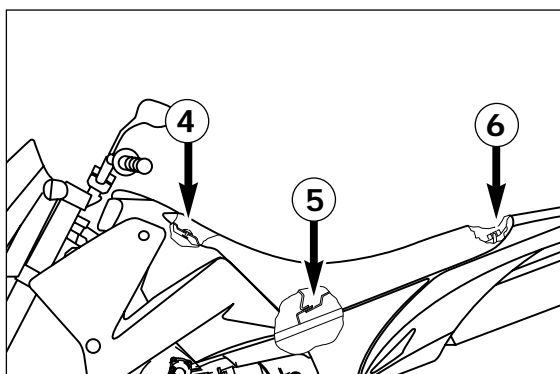

FIXING THE SEAT:

Hook the seat onto the oval head screw ❹.

Push the seat forward, at the same time depressing the middle section so that the retaining bracket ❺ engages at the seat.

Depress the rear portion of the seat until the locking bolt ❻ engages.

Take out the key.

⚠ **WARNING** ⚠

CHECK IF THE LOCKING BOLT IS PROPERLY ENGAGED. THE REAR PORTION OF THE SEAT MUST BE FIXED SO THAT IT CAN'T BE LIFTED. IF THE SEAT IS LOOSE, THE MOTORBIKE CAN EASILY GET OUT OF CONTROL.

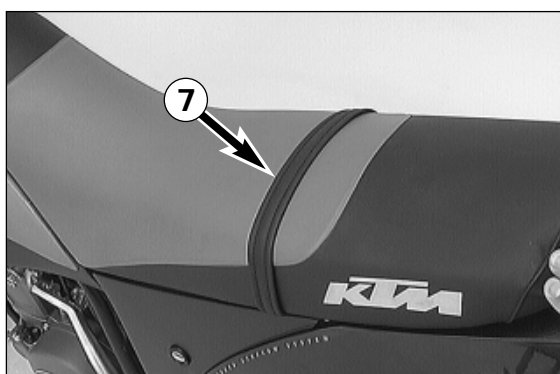

Supporting strap for the passenger

The passenger can hold on to the supporting strap on the seat.

Check the following before each start

When you start off, the motorcycle must be in a perfect technical condition. For safety reasons, you should make a habit of performing an overall check of your motorcycle before each start.

The following checks should be performed:

- 1 **CHECK THE OIL LEVEL**
Insufficient oil results in premature wear and consequently to engine damage.
- 2 **FUEL**
Check that there is sufficient fuel in the tank.
- 3 **CHAIN**
A loose chain can fall off; an extremely worn chain can tear, and insufficient lubrication can result in unnecessary wear to the chain and rear sprockets.
- 4 **TIRES**
Check for damaged tires. Tires showing cuts or dents must be replaced. The tread depth must comply with the legal regulations. Also check the air pressure. Insufficient tread and incorrect air pressure reduce the driving performance.
- 5 **BRAKES**
Check correct functioning of the braking system. Check for sufficient brake fluid in the reservoir. If the level of brake fluid falls below the minimum value, this indicates a leak in the braking system or completely worn out brake pads. Arrange for the braking system to be checked by a KTM specialist garage, as complete failure of the braking system can be expected.
Also check the state of the brake hoses and the thickness of the brake linings. Brake linings measured at their thinnest point should not be less than 1 mm since extremely worn linings can lead to brake failure.
- 6 **CABLES**
Check correct setting and easy running of all control cables.
- 7 **COOLING LIQUID**
Check the level of cooling liquid when the engine is cold.
- 8 **ELECTRICAL SYSTEM**
Check correct functioning of headlamps, parking light, tail-light, brake light, flashers, indicator lamps and horn while the engine is running.
- 9 **LUGGAGE**
If you are taking luggage with you, check that this is securely fastened.



WARNING



- WEAR SUITABLE CLOTHING WHEN DRIVING A MOTORCYCLE. CLEVER KTM DRIVERS ALWAYS WEAR A HELMET, BOOTS, GLOVES AND A JACKET, REGARDLESS OF WHETHER DRIVING ALL DAY OR JUST FOR A SHORT TRIP. THE PROTECTIVE CLOTHING SHOULD BE BRIGHTLY COLOURED SO THAT OTHER USERS OF THE ROADS CAN SEE YOU AS EARLY AS POSSIBLE. YOUR PASSENGER OF COURSE WILL ALSO NEED SUITABLE PROTECTIVE CLOTHING.
- ALWAYS TURN ON THE LIGHT TO MAKE SURE THAT OTHER DRIVERS BECOME AWARE OF YOU AS EARLY AS POSSIBLE.
- DO NOT DRIVE AFTER HAVING CONSUMED ALCOHOL.
- ONLY USE ACCESSORIES THAT HAVE BEEN RELEASED BY KTM. FOR EXAMPLE, FRONT PANELLING CAN IMPAIR THE DRIVING PROPERTIES OF THE MOTORCYCLE. CASES, EXTRA TANKS ETC. CAN ALTER THE WEIGHT DISTRIBUTION AND THUS ALSO IMPAIR THE VEHICLE'S DRIVING PROPERTIES.
- THE FRONT AND REAR WHEEL ARE ONLY ALLOWED TO BE TIRED WITH TIRES THAT HAVE THE SAME PROFILE TYPE.

Instructions for initial operation

- Verify that your KTM dealer performed the PREPARATION OF VEHICLE jobs (see Customer Service Manual).
- Read the entire manual carefully before your first drive.
- Familiarize yourself with the operating elements.
- Adjust the foot brake pedal and the hand brake lever to the most comfortable positions for you.
- Get used to handling the motorcycle on an empty car park, before starting on a longer drive. Also try to drive as slowly as possible and in standing position, to improve your feeling for the vehicle.
- Hold the handlebar with both hands and leave your feet on the foot rests while driving.
- Remove your foot from the foot brake pedal when you are not braking. If the foot brake pedal is not released the brake pads rub continuously and the braking system is overheated.
- You may only be accompanied by a passenger if your motorcycle is fitted and registered for such purposes. The passenger must hold on to the supporting strap or the driver and keep his feet on the passenger footrests throughout the ride.
- Do not make any alterations to the motorcycle and always use ORIGINAL KTM SPARE PARTS. Spare parts from other manufacturers can impair the safety of the motorcycle.
- New tires have a smooth surface and must be run in. For this purpose, carefully ride the motorcycle at moderate speed, tilting the vehicle at different angles so that the surface is evenly roughened. Tires will not display their full grip characteristics before they are properly run in.
- Motorcycles are sensitive to alterations in the distribution of weight. If you are taking luggage with you, this should be secured as close as possible to the middle of the vehicle; distribute the weight evenly between the front and rear wheel. Never exceed the maximum permissible laden weight and the axle weights. The maximum permissible laden weight is made up of the following components:
 - Motorcycle ready for operation and tank full
 - Luggage
 - Driver and passenger with protective clothing and helmet.
- Pay attention to running in instructions.

Running in

Even finely machined surfaces of engine parts have rougher surfaces than parts that slide on each other for a long time. Therefore, every engine must be run in. For this reason, do not demand maximum performance from the engine for the first 100 kilometers. The vehicle must be run in at low, changing performance level for the first 1000 KM (620 miles). The maximum number of revolutions per minute must not go exceed 4800 rpm. Once you have run your engine in for 1000 km (620 mi), you may push it to its 8500 rpm limit, i.e. up to the red zone indicated in the tachometer. Exceeding the above listed rotations as well as pushing high rpm when the engine is cold will have an adverse effect on the life of your engine.

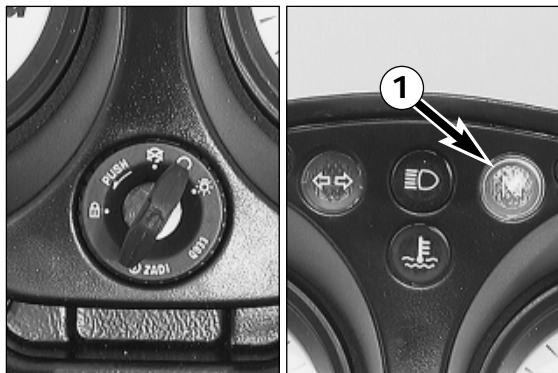

Starting when the engine is cold

- 1 Open the fuel tap.
- 2 Turn on the ignition (ignition key position: ○).
- 3 Switch the gear to neutral (green lamp 1 lights).
- 4 Turn on the emergency OFF switch 2 (if fitted).
- 5 Operate the choke lever 3.
- 6 Operate the starter button 5 without accelerating.
- 7 If the engine starts, push the choke lever back a little bit, as soon as the engine runs unevenly.
- 8 Swing up the sidestand 4.
- 9 Switch on the light before setting off. (Ignition key in position ☼).

⚠ **WARNING** ⚠

DO NOT START THE ENGINE AND ALLOW IT TO IDLE IN A CLOSED ROOM. EXHAUST FUMES ARE POISONOUS AND CAN CAUSE LOSS OF CONSCIOUSNESS AND DEATH. ALWAYS PROVIDE ADEQUATE VENTILATION WHILE THE ENGINE IS RUNNING.

! **CAUTION** !

- MAXIMUM PERIOD FOR CONTINUOUS STARTING: 5 SECONDS. WAIT AT LEAST 5 SECONDS BEFORE TRYING AGAIN.
- DON'T RIDE YOUR MOTORCYCLE WITH FULL LOAD AND DON'T REV ENGINE WHEN COLD. BECAUSE THE PISTON IS WARMING UP FASTER THAN THE WATER COOLED CYLINDER, IT CAN CAUSE ENGINE DAMAGE. ALWAYS KEEP IN MIND THAT THE ENGINE SHOULD BE WARMED UP WITH SMALL LOAD AT MEDIUM R.P.M.

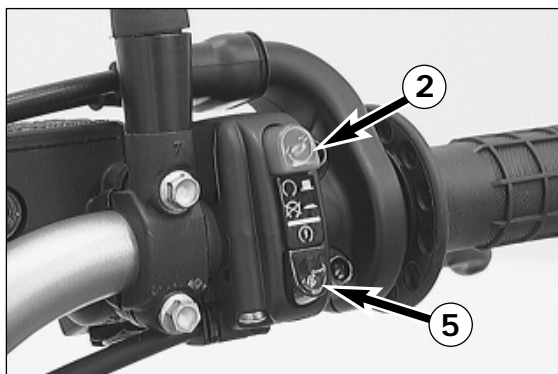

IF THE ENGINE DOES NOT CRANK WHEN YOU ACTUATE THE STARTER TIP SWITCH:

- Check if the ignition is on
- whether the emergency OFF switch (if fitted)
- Check if the emergency off switch is on
- the headlight is on (ignition lock in position ☼).
 - If this is not the case, the battery is discharged
 - If the lights are on, proceed as described in the „Trouble-shooting“ section or contact a KTM dealer.

⚠ **WARNING** ⚠

WHEN STARTING THE ENGINE, PUT ON MOTORCYCLE BOOTS IN ORDER TO AVOID INJURIES. YOU MAY SLIP OFF THE KICKSTARTER, OR THE ENGINE MAY STRIKE BACK WHEN KICKING NOT VEHEMENTLY ENOUGH.

IF THE ENGINE CRANKS BUT DOES NOT START, WHEN YOU ACTUATE THE STARTER TIP SWITCH:

- Check if the fuel tap is open
- Check if the choke lever has been operated
- Check if sufficient fuel is in the tank
 - If this is not the case, refill the tank
 - if sufficient fuel is in the tank, proceed as described in the „Trouble-shooting“ section or contact a KTM dealer.

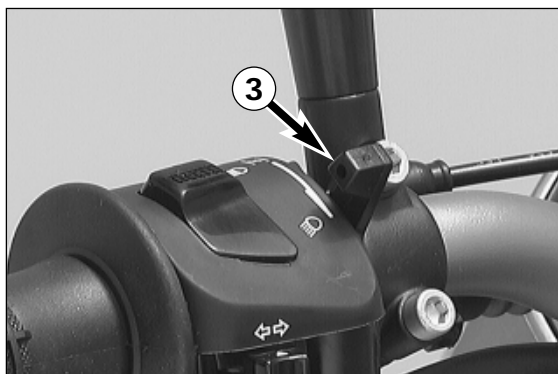

THE ELECTRIC STARTER DOESN'T CRANK THE ENGINE WHEN THE STARTER TIP SWITCH IS OPERATED EVEN THOUGH SUFFICIENT ELECTRIC CURRENT IS AVAILABLE:

- Pull the hand decompression lever 6, start and release the lever.

NOTE:

THIS MOTORCYCLE IS EQUIPPED WITH A SAFETY STARTER SYSTEM. THE ENGINE CAN ONLY BE STARTED WHEN THE TRANSMISSION IS SWITCHED TO IDLE OR THE CLUTCH LEVER IS PULLED, RESPECTIVELY.

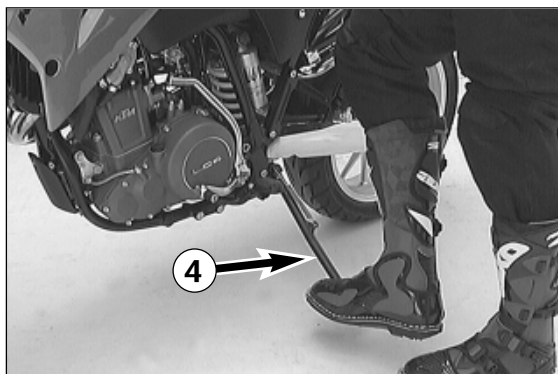

Starting when the engine is warm

- 1 Open the fuel tap.
- 2 Turn on the ignition (ignition key position: ○).
- 3 Switch the gear to neutral (green lamp 1 lights).
- 4 Turn on the emergency OFF switch 2 (if fitted).
- 5 Operate the starter button 5 without accelerating.
- 6 Swing up the sidestand 4.
- 7 Switch on the light before setting off. (Ignition key in position ☼).

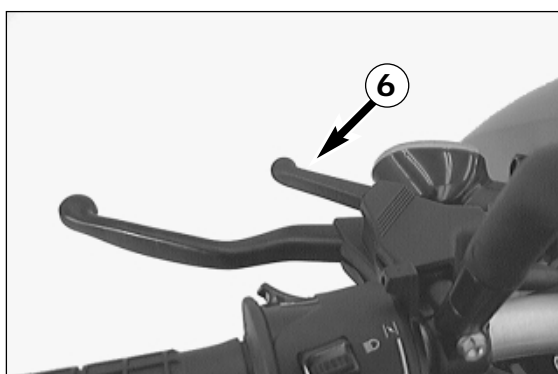

Kickstart instructions

Go to the left of your motorbike. DO NOT open the throttle, and briskly kick the kickstarter ALL THE WAY.

⚠ WARNING ⚠

- IF YOU WANT TO START THE ENGINE, MAKE SURE THAT YOU ALWAYS PUT ON STURDY MOTORCYCLE BOOTS IN ORDER TO AVOID INJURIES. YOU MIGHT SLIP OFF THE KICKSTARTER, OR THE ENGINE MAY KICK BACK AND PROPEL YOUR FOOT UPWARD WITH GREAT VEHEMENCE.
- ALWAYS KICK KICKSTARTER BRISKLY ALL THE WAY WITHOUT OPENING THE THROTTLE. KICKING THE KICKSTARTER WITH NOT ENOUGH MOMENTUM, AND AN OPENED THROTTLE GRIP INCREASE THE KICK-BACK HAZARD.

! CAUTION !

DON'T RIDE YOUR MOTORCYCLE WITH FULL LOAD AND DON'T REV ENGINE WHEN COLD. BECAUSE THE PISTON IS WARMING UP FASTER THAN THE WATER COOLED CYLINDER, IT CAN CAUSE ENGINE DAMAGE.



Starting off

Pull the clutch lever. Put the engine into first gear, slowly release the clutch lever and open throttle at the same time.

⚠ WARNING ⚠

BEFORE YOU START OFF, CHECK THAT THE SIDE STAND HAS BEEN SWUNG RIGHT UP TO THE TOP. IF THE STAND DRAGS ON THE GROUND, THE MOTORCYCLE CAN GO OUT OF CONTROL.

Shifting/Riding

You are now in first gear, referred to as the drive or uphill gear. Depending on the conditions (traffic, road gradient, etc.), you can shift to a higher gear. Close throttle, at the same time pull clutch lever and shift to the next higher gear. Let clutch lever go again and open throttle. If you turned on the choke, make sure you turn it off again as soon as engine is warm.

When you reach full speed through turning the throttle grip all the way, turn throttle back to 3/4; the speed hardly decreases although the engine will use less gas. Never open the throttle wider than the engine can handle. Excessive turning of the throttle grip will increase full consumption.

By shifting down, use the brakes if necessary and close throttle at the same time. Pull clutch lever and shift down to the next gear. Let clutch lever go slowly and open throttle or shift down again.

If the engine is killed f.ex. at a crossing, simply pull the clutch lever and start. It is not necessary to switch the gear to NEUTRAL.

⚠ WARNING ⚠

- OBSERVE THE TRAFFIC REGULATIONS, DRIVE DEFENSIVELY AND TRYING TO LOOK AHEAD AS FAR AS POSSIBLE SO THAT ANY HAZARDS CAN BE RECOGNIZED AS EARLY AS POSSIBLE.
- ADJUST YOUR DRIVING SPEED ACCORDING TO THE CONDITIONS AND YOUR DRIVING SKILLS.
- DRIVE CAREFULLY ON UNKNOWN ROADS

- AVOID ABRUPT LOAD CYCLES IN CURVES AND ON WET OR SLIPPERY ROADS. OTHERWISE, THE MOTORCYCLE COULD EASILY GET OUT OF CONTROL.
- NEVER TURN THE IGNITION KEY TO POSITION OR WHILE THE MOTORCYCLE IS MOVING.
- REPLACE THE HELMET VISOR RESPECTIVELY GOGGLE GLASSES IN PLENTY OF TIME. WHEN LIGHT SHINES DIRECTLY ON SCRATCHED VISOR OR GOGGLES, YOU WILL BE PRACTICALLY BLIND.
- AFTER FALLING WITH THE MOTORCYCLE, CHECK ALL FUNCTIONS THOROUGHLY BEFORE STARTING UP OPERATIONS AGAIN.
- A BENT HANDLEBAR MUST ALWAYS BE REPLACED. NEVER TRY TO STRAIGHTEN THE HANDLEBAR BECAUSE THIS WILL CAUSE IT TO LOSE ITS STABILITY.

! CAUTION !

- HIGH RPM RATES WHEN THE ENGINE IS COLD HAVE AN ADVERSE EFFECT ON THE LIFE OF YOUR ENGINE. WE RECOMMEND YOU RUN THE ENGINE IN A MODERATE RPM RANGE FOR A FEW MILES GIVING IT A CHANCE TO WARM UP. AFTER THAT NO FURTHER PRECAUTIONS IN THIS RESPECT NEED BE TAKEN.
- SHIFT TO THE NEXT HIGHER GEAR BY 8500 RPM AT THE LATEST. ENGINE SPEEDS IN THE RED RANGE MUST STRICTLY BE AVOIDED.
- NEVER HAVE THE THROTTLE WIDE OPEN WHEN CHANGING DOWN TO A LOWER GEAR. THE ENGINE WILL OVERSPEED, DAMAGING THE VALVES. IN ADDITION, THE REAR WHEEL BLOCKS SO THAT THE MOTORCYCLE CAN EASILY GET OUT OF CONTROL.
- LONG WHEELIE DRIVING CAUSES THE OIL PRESSURE TO DROP. THE OIL PRESSURE WILL AUTOMATICALLY INCREASE AS SOON AS YOU DRIVE ON NORMALLY. DOING WHEELIES FOR A LONG TIME WILL DAMAGE YOUR ENGINE.
- IF THE RED COOLING LIQUID TEMPERATURE LAMP LIGHTS UP WHILE YOU ARE DRIVING, THIS INDICATES COOLING SYSTEM TROUBLE. IMMEDIATELY STOP AND TURN OFF THE ENGINE. DRIVING WITH THE WARNING LAMP ON WILL CAUSE ENGINE DAMAGE.
 - PLACE A CLOTH ON THE RADIATOR CAP. OPEN THE CAP SLOWLY, SO THE EXCESS PRESSURE IN THE COOLING SYSTEM CAN ESCAPE. - CAUTION SCALDING HAZARD! - AND CHECK THE COOLING LIQUID LEVEL.
 - DO NOT DRIVE ON, UNTIL THERE IS SUFFICIENT LIQUID IN THE COOLING SYSTEM. HOWEVER, CALL ON ONE OF KTM'S DEALERS AS SOON AS POSSIBLE IN ORDER TO HAVE THE DEFECT REMEDIED.
- IF ANY ABNORMAL VIBRATIONS OCCUR WHILE DRIVING, CHECK THAT THE ENGINE FASTENING SCREWS ARE TIGHT.
- IN THE EVENT THAT, WHILE RIDING YOUR MOTORCYCLE, YOU NOTICE ANY UNUSUAL OPERATION-RELATED NOISE, STOP IMMEDIATELY, TURN THE ENGINE OFF, AND CONTACT AN AUTHORIZED KTM DEALER.

Braking

Close throttle and apply the hand and foot brakes at the same time. When driving on sandy, wet or slippery ground use mainly the rear wheel brake. Always brake with feeling, blocking wheels can cause you to skid or fall. Also change down to lower gears depending on your speed.

When driving downhill, use the braking effect of the engine. Change down one or two gears but do not overspeed the engine. In this way, you will not need to brake so much and the brakes will not overheat.

⚠ WARNING ⚠

- DELAYED BRAKE ACTION MUST BE EXPECTED DUE TO WET BRAKE DISKS DURING RAINY WEATHER OR AFTER CLEANING OF THE MOTORCYCLE. IN THIS CASE, REPEATEDLY APPLY THE BRAKES UNTIL THEY ARE DRY.
- DELAYED BRAKE ACTION CAN ALSO OCCUR ON SALTED OR DIRTY ROADS. IN THIS CASE, REPEATEDLY APPLY THE BRAKES TO REMOVE THE DIRT.
- WHEN YOU BRAKE, THE BRAKE DISCS, BRAKE PADS, BRAKE CALIPER AND BRAKE FLUID HEAT UP. THE HOTTER THESE PARTS GET, THE WEAKER THE BRAKING EFFECT. IN EXTREME CASES, THE ENTIRE BRAKING SYSTEM CAN FAIL.

Stopping and parking

Apply the brakes fully and put the engine into neutral. To stop the engine, switch off the ignition. Close fuel tap. Park on solid ground and lock the vehicle.



WARNING



- NEVER LEAVE YOUR MOTORCYCLE WITHOUT SUPERVISION AS LONG AS THE ENGINE IS RUNNING.
- MOTORCYCLE ENGINES PRODUCE A GREAT AMOUNT OF HEAT WHILE RUNNING. THE ENGINE RADIATORS, EXHAUST, EXHAUST SYSTEM, BRAKE DISCS, AND SHOCK ABSORBERS CAN BECOME VERY HOT. DO NOT TOUCH ANY OF THESE PARTS AFTER OPERATING THE MOTORCYCLE, AND TAKE CARE TO PARK IT WHERE PEDESTRIANS ARE NOT LIKELY TO TOUCH IT AND GET BURNED.
- NEVER PARK YOUR MOTORCYCLE IN PLACES WHERE THERE EXIST FIRE HAZARDS DUE TO DRY GRASS OR OTHER EASILY FLAMMABLE MATERIALS.



CAUTION



- PARK YOUR MOTORCYCLE, SO THAT IT RESTS STABLY ON THE SIDE- STAND (HARD GROUND, LEVEL SURFACE) AND CAN'T TIP OVER.
- CLOSE THE FUEL TAP WHEN LEAVING YOUR VEHICLE. OTHERWISE THE CARBURETOR CAN OVERFLOW AND FUEL WILL ENTER THE ENGINE.
- ALWAYS TAKE OUT THE IGNITION KEY WHEN PARKING YOUR MOTORCYCLE SO THAT IT CANNOT BE USED BY UNAUTHORIZED PERSONS.

NOTE REGARDING THE SIDE STAND:

Use your foot to kick side stand forward up to the stop and lean the motorcycle sideways. Make sure that the ground is solid and that your motorcycle is standing securely. Just in case, you can shift into first gear.



CAUTION



THE SIDE STAND IS DESIGNED TO BEAR ONLY THE LOAD OF THE MOTORCYCLE. THE SIDE STAND AND/OR THE FRAME CAN BE DAMAGED AND THE MOTORCYCLE CAN FALL OVER IF YOU MOUNT THE MOTORCYCLE, THUS PUTTING AN ADDITIONAL LOAD ON THE SIDE STAND.



A washed motorcycle can be checked more quickly which saves money!

1. Service after 1000 km

2. Service after 5000 km, then every 5000 km or once a year

		1. Service after 1000 km	2. Service after 5000 km, then every 5000 km or once a year
ENGINE	Change engine oil, oil filter, and fine filter	●	●
	Clean oil screens and magnet of drain plug	●	●
	Check oil lines for damage and kink-less arrangement	●	●
	Check and adjust spark plug, replace it every 10,000 km		●
	Check and adjust valve clearance	●	●
	Check engine fastening screws for tight fit	●	●
CARBURETOR	Check carburetor connection boots for cracks and leaks		●
	Check idle setting	●	●
	Check bleeder hoses for damage and kink-free arrangement	●	●
ADD-ON-PARTS	Check cooling system for leaks, antifreeze protection	●	●
	Check radiator fan for proper function		●
	Check exhaust system for leaks and suspension	●	●
	Check actuating cables for damage, smooth operation, and kink-less arrangement, adjust and lubricate	●	●
	Clean air filter and air filter box		●
	Check cables for damage and kink-less arrangement		●
	Check headlamp adjustment		●
	Check electrical system for function (low/high beams, stop light, turn indicators, headlamp flasher, tell-tale lamps, speedometer illumination, horn, side-stand switch, clutch switch, emergency-off switch)	●	●
BRAKES	Check brake fluid level, lining thickness, and brake discs	●	●
	Check brake lines for damage and leaks	●	●
	Check/adjust smooth operation, free travel of handbrake/footbrake levers		● ●
	Check screws of brake system for tight fit	●	●
CHASSIS	Check suspension strut and fork for leaks and proper function	●	●
	Check O-ring of suspension strut for wear		●
	Clean dust sleeves		●
	Bleed fork legs	●	●
	Check swinging-fork pivot	●	●
	Check/adjust steering-head bearing	●	●
	Service eccentric for chain tension		●
	Lubricate reversing lever		●
	Check all chassis screws for tight fit (fork plates, fork leg, axle nuts/screws, swinging-fork pivot, reversing lever, suspension strut)	●	●
WHEELS	Check tire condition, inflation pressure, and rim condition	●	●
	Check chain, chain wheels, chain wheel guides for wear, tight fit, and tension	●	●
	Lubricate chain	●	●
	Check wheel bearings and jerk damper for play		●

IMPORTANT RECOMMENDED MAINTENANCE PROCEDURES TO BE PERFORMED BASED ON A SEPARATE SUPPLEMENTARY ORDER

	at least once a year	every 2 years or 20000 km
Perform complete fork maintenance	●	
Perform complete suspension strut maintenance		●
Perform complete reversing lever maintenance		●
Replace glass-fiber yarn packing of the silencers		●
Clean and lubricate steering-head bearing and sealing elements	●	
Clean and adjust the carburetor	●	
Treat the electrical contacts and switches with contact spray	●	
Treat battery connections with contact grease	●	
Change the brake fluid	●	

IF MOTORCYCLE IS USED FOR COMPETITION 5000 KM SERVICE SHOULD BE CARRIED OUT AFTER EVERY RACE! SERVICE INTERVALLS SHOULD NEVER BE EXCEED BY MOOR THAN 500 KM! MAINTENANCE WORK DONE BY KTM AUTHORISED WORKSHOPS IS NOT A SUBSTITUTE OF CARE AND CHECKS DONE BY THE RIDER!

VITAL CHECKS AND CARE PROCEDURES TO BE CONDUCTED BY THE OWNER OR THE MECHANIC

	before each start	after every cleaning	for competition use	once a year
Check oil level	●			
Check brake fluid level	●			
Check brake pads for wear	●			
Check lighting system for proper function	●			
Check horn for proper function	●			
Lubricate and adjust actuating cables and nipples		●		
Bleed fork legs in regular intervals			●	●
Remove and clean dust sleeves in regular intervals			●	●
Clean and lubricate chain as necessary		●	●	
Check chain tension	●	●	●	
Clean air filter and filter box			●	●
Check tire pressure and wear	●			
Check coolant level	●			
Check fuel lines for leaks	●			
Drain float chamber		●		
Verify smooth operation of all controls	●			
Check braking performance	●	●		
Treat exposed metal components (except for the braking and exhaust systems) with wax-based anti-corrosion agents		●		
Treat ignition/steering lock and light switch with contact spray		●		
Check all screws, nuts, and hose clamps for their tight fit				●

MAINTENANCE WORK ON CHASSIS AND ENGINE



WARNING



MAINTENANCE AND ADJUSTING WORK MARKED WITH AN ASTERISK (*) REQUIRES EXPERT SKILLS AND TECHNICAL KNOW-HOW. FOR YOUR OWN SAFETY, ALWAYS HAVE SUCH WORK PERFORMED BY A SPECIALIZED KTM DEALER WHERE YOUR MOTORCYCLE WILL BE OPTIMALLY SERVICED BY APPROPRIATELY QUALIFIED SKILLED STAFF.



CAUTION



- WHEN CLEANING THE MOTORCYCLE, DO NOT USE A HIGH PRESSURE CLEANING UNIT IF POSSIBLE, OTHERWISE WATER WILL PENETRATE THE BEARINGS, CARBURETOR, ELECTRIC CONNECTORS ETC.
- WHEN TRANSPORTING YOUR KTM, ENSURE THAT IT IS HELD UPRIGHT WITH RESTRAINING STRAPS OR OTHER MECHANICAL FASTENING DEVICES. IF THE MOTORCYCLE SHOULD FALL OVER, FUEL CAN LEAK FROM THE CARBURETOR OR FUEL TANK
- DO NOT USE TOOTHED WASHERS OR SPRING WASHERS WITH THE ENGINE FASTENING SCREWS, AS THESE WORK INTO THE FRAME PARTS AND KEEP WORKING LOOSE. INSTEAD, USE SELF-LOCKING NUTS.
- LET YOUR MOTORCYCLE COOL DOWN BEFORE BEGINNING ANY MAINTENANCE WORK IN ORDER TO AVOID GETTING BURNED.
- DISPOSE OF OIL, GREASE, FILTERS, FUELS, CLEANING AGENTS ETC. ACCORDING TO YOUR LOCAL REGULATIONS.
- UNDER NO CIRCUMSTANCES MAY USED OIL BE DISPOSED OF IN THE SEWAGE SYSTEM OR IN THE OPEN COUNTRYSIDE. 1 LITER USED OIL CONTAMINATES 1.000.000 LITERS WATER.

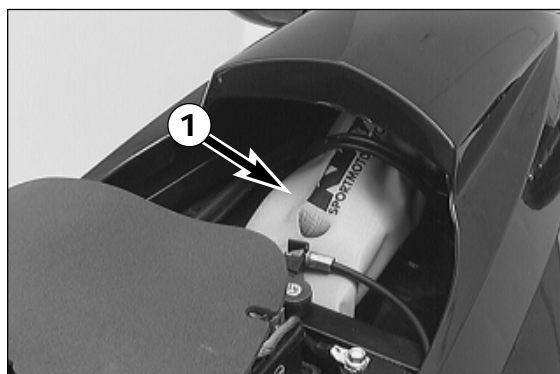

Tool kit

The tool kit ❶ is stored below the seat.

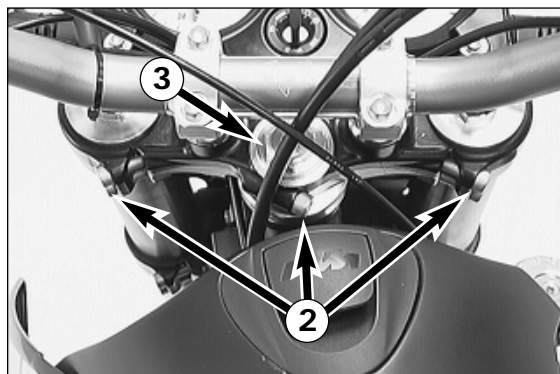

Checking and adjusting the steering head bearing*

Check steering head bearing for play periodically. To check this, put motorcycle on stand so that the front wheel is off the ground. Now try to move the fork forward and backward - no play should be discernable. To adjust, loosen the five clamp screws ❷ of the top triple clamp and turn steering stem bolt clockwise ❸ until there is no more play. Don't tighten the steering stem bolt all the way, otherwise the bearings will be damaged. With a plastic hammer, lightly tap on the top triple clamp to release tension. Re-tight the five clamp screws to 15 Nm (11 ft.lb).



WARNING



IF THE STEERING HEAD BEARING IS NOT ADJUSTED TO BE FREE OF PLAY, THE MOTORCYCLE WILL SHOW AN UNSTEADY DRIVING PERFORMANCE AND CAN GET OUT OF CONTROL.



CAUTION



IF YOU DRIVE WITH PLAY IN THE STEERING HEAD BEARING FOR LONGER PERIODS, FIRSTLY THE BEARINGS AND THEN THE BEARING SEATS IN THE FRAME WILL BE DESTROYED.

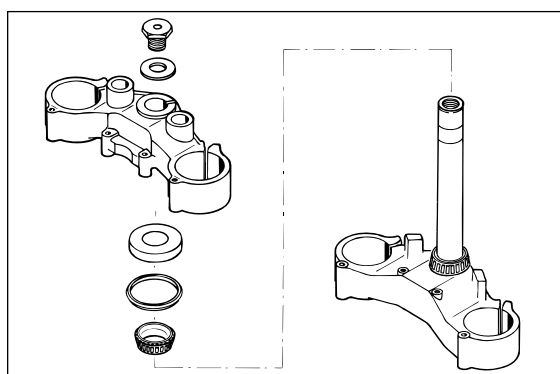

At least once a year, the steering head bearings should be greased.

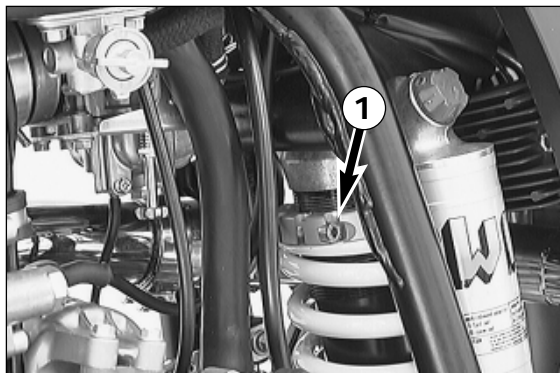

Changing the spring preload of the shock absorber

KTM sets the shock absorber for a driver only, weighing approximately 75 kg (165 lb). If you want to take a passenger with you, or if you weigh considerably more or less than 75 kg (165 lb), you should change the spring preload accordingly. This is easily done.

NOTE:

- Before changing the spring preload note down the basic setting, e.g. how many threads are visible above the adjusting ring.
- One rotation of the adjusting ring ❸ changes the spring preload by approximately 2 mm.

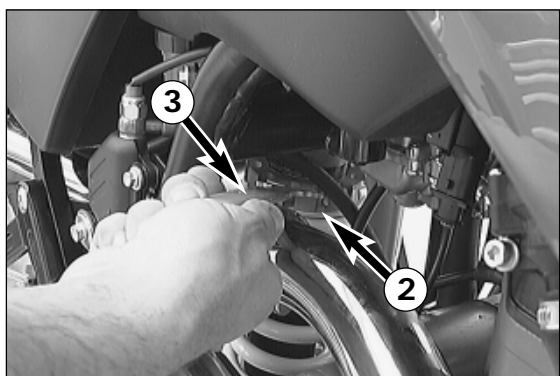

Loosen the allen head screw ❶ at the adjustment ring ❷. Use the special wrench ❸ from the tool set to turn the adjusting ring as required. Place the adjusting ring in a suitable position, and tighten the allen head screw with 8 Nm (6 ft.lb).

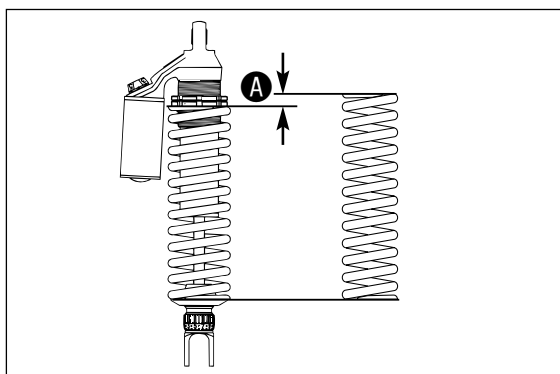

ADJUSTMENT VALUES - SPRING PRELOAD:

Minimum preload.....	10 mm
Preload driver only 75 kg BASIC SETTING	23 mm
Preload with passenger.....	28 mm

❶ = spring preload

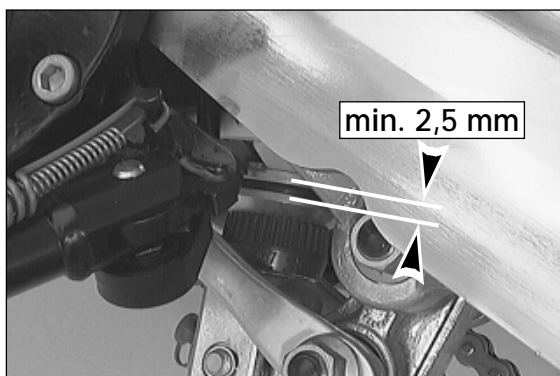

Checking the rubber ring of the rear shock absorber

A rubber ring mounted on the rear shock absorber serves as a vibration damper. This ring gets pressed together with time and loses its shock absorbing quality.

Measure the distance between the two discs at various points around their circumferences. The space should be at least 2.5 mm wide. Have the rubber ring replaced in a KTM garage when compaction due to wear has exceeded the limit.

! CAUTION !

NOT REPLACING THE RUBBER RING IN TIME CAN RESULT IN DAMAGE TO THE SHOCK ABSORBER.

⚠ WARNING ⚠

THE DAMPING UNIT OF THE SHOCK ABSORBER IS FILLED WITH HIGHLY COMPRESSED NITROGEN. NEVER TRY TO TAKE THE SHOCK ABSORBER APART OR TO DO ANY MAINTENANCE WORK YOURSELF. SEVERE INJURIES COULD BE THE RESULT.

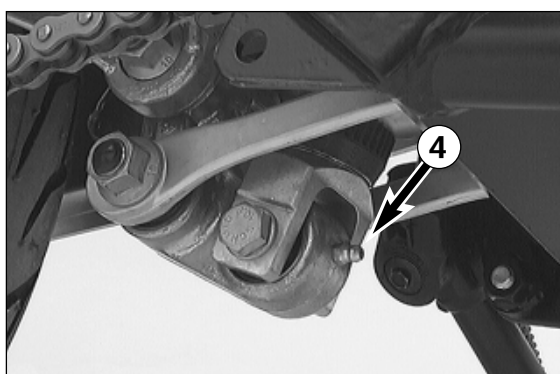

Lubricating the shock absorber linkage

The bearings in the rocker arm must be greased in regular intervals. For this purpose, a grease nipple ❹ is mounted on the rocker arm.

! CAUTION !

AFTER EACH TIME THE MOTORCYCLE IS WASHED, IT IS ESPECIALLY IMPORTANT TO GREASE THE GREASE NIPPLE TO PUSH ANY WATER OUT OF THE BEARINGS.

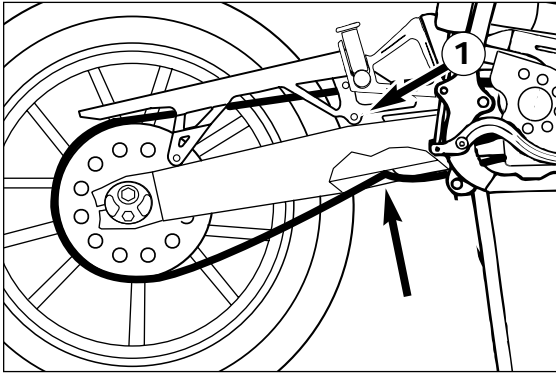

Checking chain tension

To check chain tension, turn off the engine and shift into neutral. Chain tension is correct when the chain can just barely be pushed up to touch the swingarm at the level of the screw ❶ (see illustration). If necessary, correct chain tension.

⚠ **WARNING** ⚠

- IF CHAIN TENSION IS TOO GREAT, PARTS WITHIN THE SECONDARY POWER TRANSMISSION (CHAIN, CHAIN SPROCKETS, TRANSMISSION AND REAR WHEEL BEARINGS) WILL BE SUBJECTED TO UNNECESSARY STRESS, RESULTING IN PREMATURE WEAR AND EVEN CHAIN BREAKAGE.
- TOO MUCH SLACK IN THE CHAIN, ON THE OTHER HAND, CAN RESULT IN THE CHAIN JUMPING OFF THE CHAIN WHEELS. IF THIS HAPPENS, THE CHAIN COULD ALSO BLOCK THE REAR WHEEL OR DAMAGE THE ENGINE.
- IN EITHER CASE THE OPERATOR IS LIKELY TO LOSE CONTROL OF THE MOTORCYCLE.

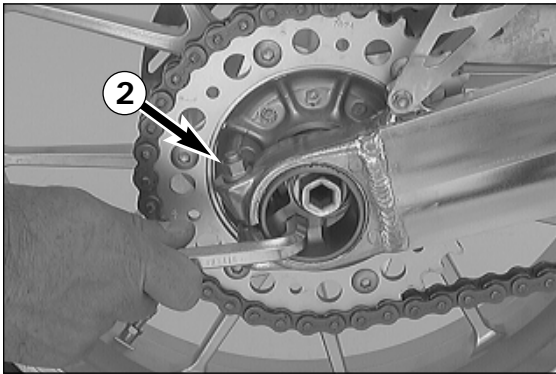

Correcting chain tension

Loosen hexagon nuts ❷ on the left and right swingarm fists.

Loosen allen head screw ❸.

Insert the hexagon socket wrench that comes with the tool set into the hexagon socket of the eccentric and rotate the eccentric upwards (i.e. the wheel spindle must move upwards).

! **CAUTION** !

IF THE WHEEL SPINDLE BECOMES LOOSE DURING THE PROCESS, RETURN ECCENTRICS TO THEIR ORIGINAL POSITION BEFORE RETIGHTENING THE WHEEL SPINDEL (SEE MAINTAINING ECCENTRICS)

Tighten hexagon nuts on swing arm fists to 40 Nm (30 ft.lb).

Tighten allen head screw ❸ to 40 Nm (30 ft.lb).

⚠ **WARNING** ⚠

- DO NOT ROTATE THE ECCENTRIC DOWNWARDS (I.E. THE WHEEL SPINDLE MOVES DOWNWARDS). THIS WILL RAISE THE TAIL OF THE MOTORCYCLE AND WORSEN THE MOTORCYCLE'S PERFORMANCE ON THE STRAIGHTAWAY.
- IF YOU DON'T HAPPEN TO HAVE A TORQUE WRENCH AT HAND, MAKE SURE YOU HAVE THE TIGHTENING TORQUE CORRECTED BY A KTM DEALER AS SOON AS POSSIBLE.

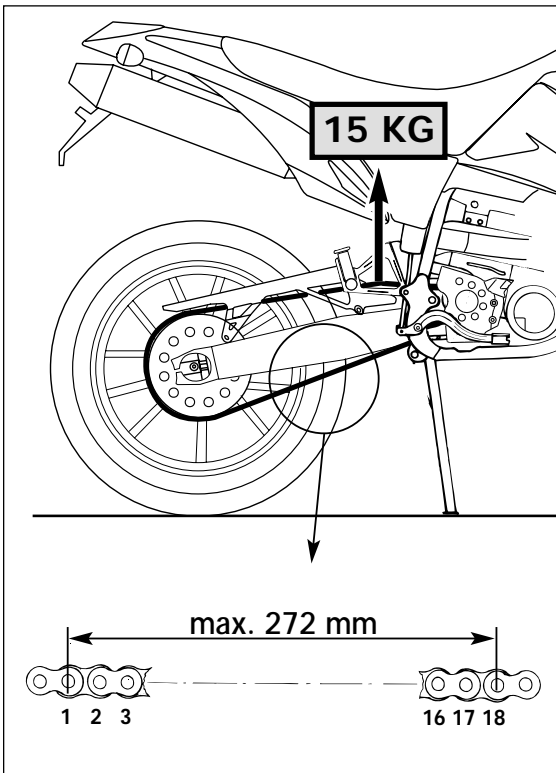
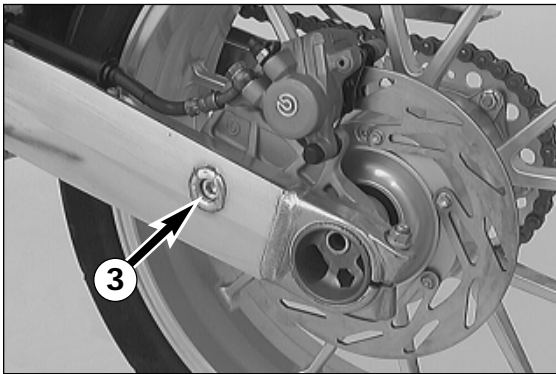

Chain wear

In order to check the chain wear, regard the following instructions:

Shift the gear into idling and pull the upper chain strand with approx. 10-15 kilogramm (33 lb) upwards (see figure). Now one can measure a space of 18 chain reels at the lower chain strand. The chain should be replaced at the latest when a space of 272 mm (10,70 in) is measured. Chains do not always wear off evenly, therefore repeat the measurement at different places on the chain.

NOTE:

If you mount a new chain, the sprockets should also be replaced. New chains wear faster if used on old used sprockets.

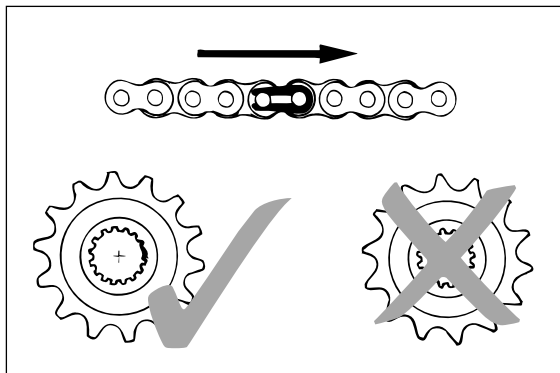

Chain maintenance

O-ring chains require only modest maintenance. The best way is to use lots of water, but never use brushes or solvents. After letting the chain dry, you can use a special O-ring chain spray (i.e. Shell Advance Bio Chain).

⚠ WARNING ⚠

NO LUBRICATION IS ALLOWED TO REACH THE REAR TIRE OR THE BRAKE DISK, OTHERWISE THE ROAD ADHERENCE AND THE REAR WHEEL BRAKING EFFECTS WOULD BE STRONGLY REDUCED AND THE MOTORCYCLE COULD EASILY GET OUT OF CONTROL.

! CAUTION !

WHEN MOUNTING THE CHAIN JOINT, THE CLOSED SIDE OF THE SAFETY DEVICE MUST POINT IN RUNNING DIRECTION.

ALSO CHECK SPROCKETS AND CHAIN GUIDES FOR WEAR, AND REPLACE IF NECESSARY.

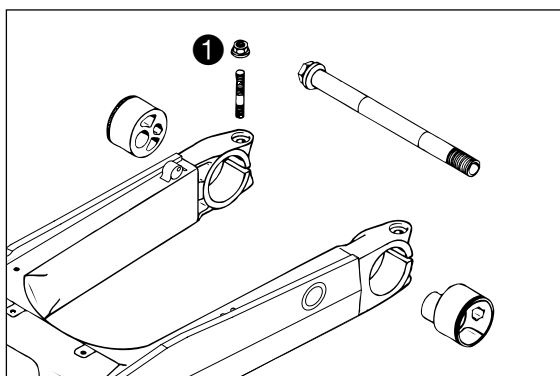

Maintaining chain tension eccentrics

To ensure trouble-free adjustment, take the chain tension eccentrics out at least once a year for maintenance them. To do this:

Remove rear wheel.

Loosen hexagon nuts ① on the left and right swing arm fists.

Remove eccentrics.

Clean eccentrics and swing arm fists thoroughly and grease the slide faces with a Molykote grease or spray.

Replace eccentrics (eccentric with the thread goes in the left swing arm fist).

Turn both eccentrics to the same position (marks should be aligned with the notches in the swing arm fists).

Tighten hexagon nuts on the swing arm fists with 40 Nm (30 ft.lb).

Mount the rear wheel and tighten the wheel spindle to 80 Nm (59 ft.lb).

Adjust the chain tension.

⚠ WARNING ⚠

IF YOU DON'T HAPPEN TO HAVE A TORQUE WRENCH AT HAND, MAKE SURE YOU HAVE THE TIGHTENING TORQUE CORRECTED BY A KTM DEALER AS SOON AS POSSIBLE.

! CAUTION !

IF THE ECCENTRICS ARE NOT ALIGNED, THE REAR WHEEL WILL REST AT AN ANGLE IN THE SWING ARM. THIS WILL STRESS THE REAR WHEEL AND SWING ARM BEARINGS AND DAMAGE THEM IF NOT CORRECTED.

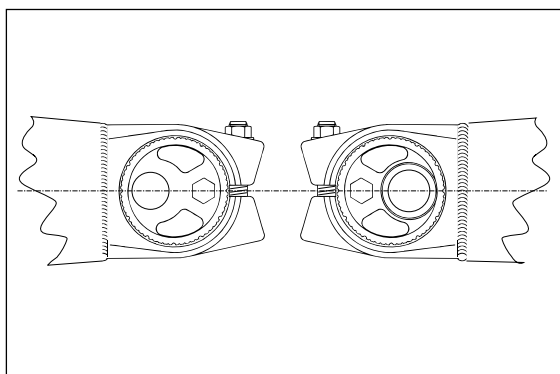

General information about KTM disc brakes

BRAKE CALIPERS:

The front brake caliper has 4 brake pistons and is rigidly connected to the fork leg. The rear brake caliper has one brake piston and "floats", which means that it is not rigidly connected to the brake caliper support. The resulting lateral adjustment ensures that the brake pads optimally rest against the brake disk at any time.

BRAKE PADS:

The motorcycle is equipped with organic brake linings. The thinnest point of the lining must not be thinner than 1 mm.

BRAKE DISCS:

Due to wear, the thickness of the brake disc in the area of the contact face ② of the brake pads decreases. At their thinnest point ①, the brake discs must not be more than 0.4 mm (0,016 in) thinner than the pad's nominal thickness. Measure the nominal thickness in a location ③ outside the contact face. Check wear in several locations.

⚠ WARNING ⚠

- BRAKE DISCS SUFFERING FROM WEAR GREATER THAN 0,4 MM (0,016 IN) CONSTITUTE A SAFETY RISK. HAVE THE BRAKE DISCS REPLACED IMMEDIATELY AS SOON AS THEY REACH THE WEAR LIMIT.
- HAVE ANY REPAIRS ON THE BRAKE SYSTEM BE PERFORMED BY A KTM DEALER

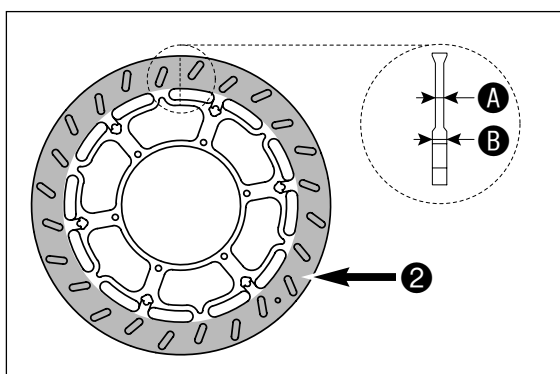

BRAKE FLUID RESERVOIRS:

The brake fluid reservoirs on front and rear wheel brakes have been designed in such a way that even if the brake pads are worn it is not necessary to top up the brake fluid. If the brake fluid level drops below the minimum level either the brake system has a leak or the brake pads are completely worn. In this case, consult an authorized KTM dealer immediately.

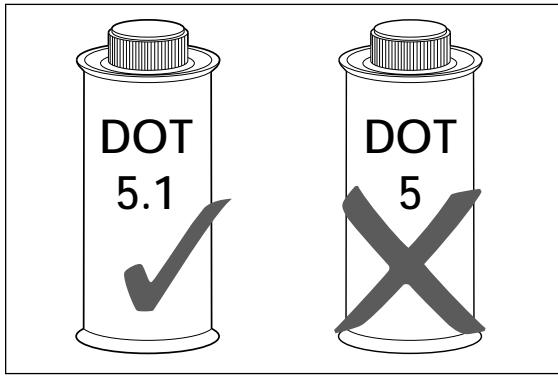

BRAKE FLUID:

KTM fills the brake systems with SHELL ADVANCE BRAKE DOT 5.1 brake fluid, one of the best brake fluids that is currently available. We recommend that you continue to use it. DOT 5.1 brake fluid is based on glycol ether and of an amber color. If you do not have any DOT 5.1 for refilling, you may use DOT 4 brake fluid. However, you should replace it as soon as possible by DOT 5.1.

Never use brake fluid DOT 5. The color of this silicon oil-based product is purple red. The gaskets and brake hoses of KTM motorcycles are not designed for DOT 5 brake fluid!

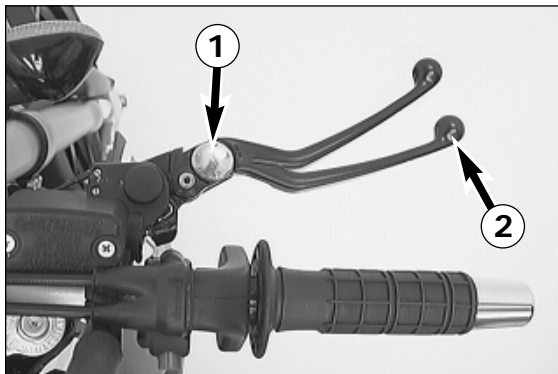

Changing the basic position of the handbrake lever

The adjusting screw ❶ allows you to change the basic position of the handbrake lever ❷.

Press the handbrake lever's outer end forward, and, at the same time, turn the adjusting screw.

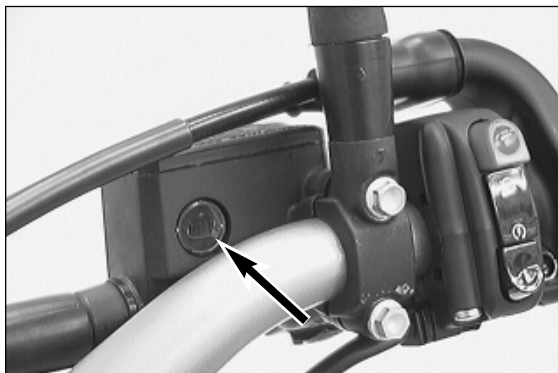

Checking of brake fluid level - front brake

The brake fluid reservoir is linked with the hand brake cylinder at the handlebar and the reservoir is provided with an inspection glass. With the reservoir in a horizontal position, the brake fluid level should not drop below the middle of the glass. The reservoir should be kept completely full at all times for best performance.

⚠ WARNING ⚠

- IF THE BRAKE FLUID LEVEL DROPS BELOW THE MINIMUM EITHER THE BRAKE SYSTEM HAS A LEAK OR THE BRAKE PADS ARE COMPLETELY WORN. IN THIS CASE, CONSULT AN AUTHORIZED KTM DEALER IMMEDIATELY.
- CHANGE BRAKE FLUID AT LEAST ONCE A YEAR. IF THE MOTORCYCLE IS BEING WASHED VERY OFTEN, CHANGE BRAKE FLUID MORE OFTEN. BRAKEFLUID HAS THE ABILITY TO ADMIT WATER; THEREFORE, STEAM BUBBLES CAN FORM IN „OLD“ BRAKE FLUID AT RELATIVELY LOW TEMPERATURES THUS CAUSING THE BRAKE SYSTEM TO FAIL.

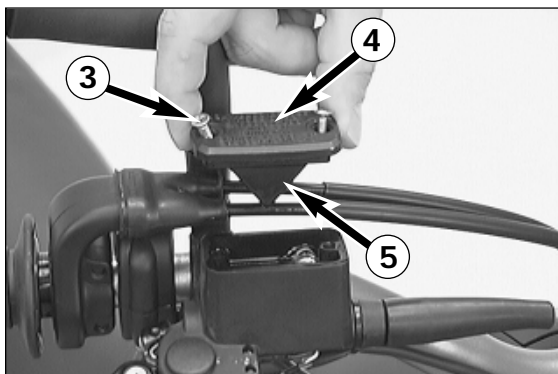

Refilling the front brake fluid reservoir *

When the brake fluid falls to the middle of the inspection glass, new brake fluid has to be added.

Loosen screws ❸ and remove lid ❹ and membrane ❺.

Place hand brake cylinder in a horizontal position and fill the brake fluid reservoir to 5 mm (0,2 in) below the rim with clean brake fluid DOT 5.1 (Shell Advance Brake DOT 5.1). Replace membrane and lid, tighten screws. Rinse off spilled or overflowing brake fluid with water.

⚠ WARNING ⚠

- NEVER USE DOT 5 BRAKE FLUID! IT IS BASED ON SILICONE OIL AND OF A PURPLE COLOR. SEALS AND BRAKE HOSES MUST BE ESPECIALLY ADAPTED TO IT.
- STORE BRAKE FLUID OUT OF REACH OF CHILDREN.
- BRAKE FLUID CAN CAUSE SKIN IRRITATION. AVOID CONTACT WITH SKIN AND EYES. IF YOU GET BRAKE FLUID IN YOUR EYES, RINSE WITH PLENTY OF WATER AND CONSULT A DOCTOR.

! CAUTION !

- DON'T LET BRAKE FLUID GET IN CONTACT WITH PAINT, IT IS AN EFFECTIVE PAINT REMOVER.
- USE ONLY CLEAN BRAKE FLUID TAKEN FROM A TIGHTLY SEALED CONTAINER.

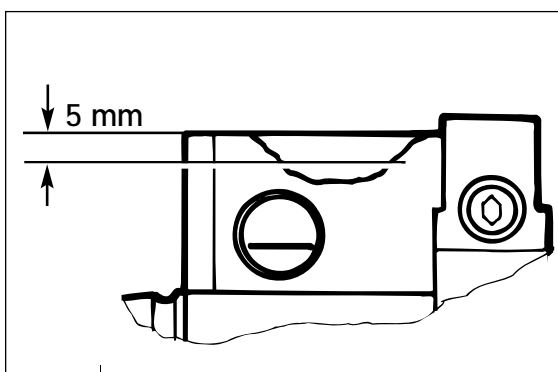

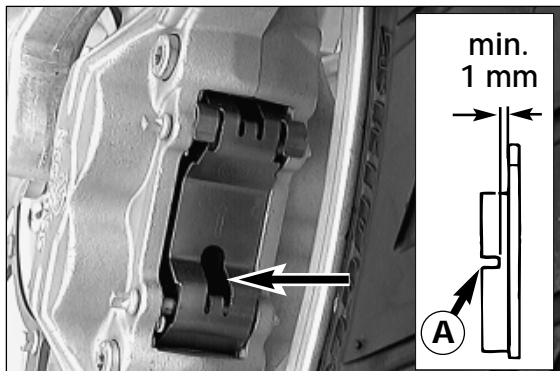

Checking the front brake pads

The brake pads can be inspected from behind. Always inspect the brake pad linings before taking off on your motorcycle. They should not be thinner than 1 mm which is the case when the notch **A** is no longer discernable.

⚠ WARNING ⚠

AT THEIR MOST WORN POINT BRAKE PAD LININGS SHOULD NOT BE THINNER THAN 1 MM, OTHERWISE THEY COULD LEAD TO BRAKE FAILURE. FOR YOUR OWN SAFETY DON'T PUT OFF HAVING YOUR BRAKE PADS CHANGED.

! CAUTION !

IF THE BRAKE PADS ARE REPLACED TOO LATE SO THAT THE LINING IS PARTLY OR ENTIRELY WORN AWAY, THE STEEL COMPONENTS OF THE BRAKE PAD WILL RUB AGAINST THE BRAKE DISC, SIGNIFICANTLY IMPAIRING THE BRAKING EFFECT AND DESTROYING THE BRAKE DISC.

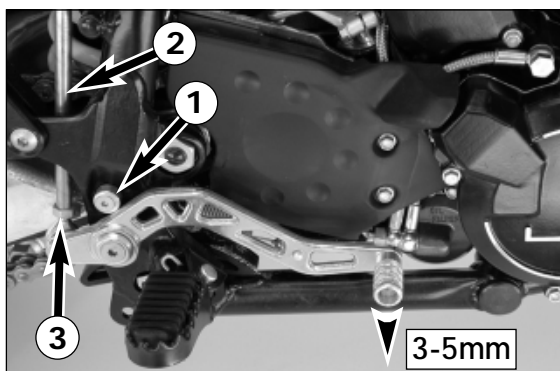

Changing the basic position of the brake pedal *

The basic setting of the foot brake pedal can be changed by turning the stop roller **1**. Using the piston rod **2**, the free play on the foot brake pedal must be set. In order to be able to turn the piston rod, the counter nut **3** must first be loosened.

Measured on the outside, the foot brake pedal must have 3-5 mm of free play, before the piston rod can move the piston in the brake cylinder (to be recognised from the resistance on the foot brake pedal). Retighten counter nut **3**.

! CAUTION !

IF THIS CLEARANCE IS MISSING, PRESSURE ACCUMULATES IN THE BRAKING SYSTEM AND THE BRAKE PADS BEGIN TO RUB. THE BRAKING SYSTEM OVERHEATS AND CAN FAIL COMPLETELY IN EXTREME CASES.

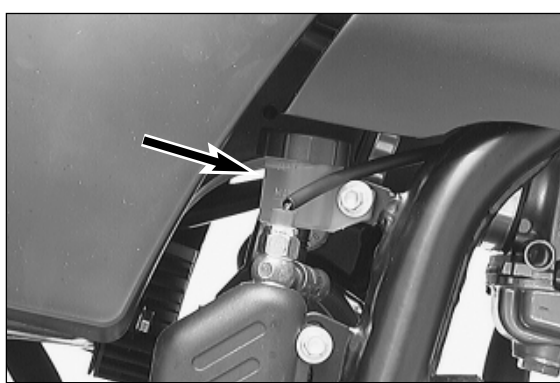

Checking the rear brake fluid level

The reservoir for the rear disc brake is located on the left-hand side of the vehicle next to the carburetor carburetor connection boot. The brake fluid level may not drop below the „MIN“ marking when the vehicle is in an upright position.

⚠ WARNING ⚠

- IF THE BRAKE FLUID LEVEL DROPS BELOW THE MINIMUM EITHER THE BRAKE SYSTEM HAS A LEAK OR THE BRAKE PADS ARE COMPLETELY WORN. IN THIS CASE, CONSULT AN AUTHORIZED KTM DEALER IMMEDIATELY.
- CHANGE BRAKE FLUID AT LEAST ONCE A YEAR. IF THE MOTORCYCLE IS BEING WASHED VERY OFTEN, CHANGE BRAKE FLUID MORE OFTEN. BRAKEFLUID HAS THE ABILITY TO ADMIT WATER; THEREFORE, STEAM BUBBLES CAN FORM IN „OLD“ BRAKE FLUID AT RELATIVELY LOW TEMPERATURES THUS CAUSING THE BRAKE SYSTEM TO FAIL.



Refilling the rear brake fluid reservoir*

When the brake fluid level has dropped to the MIN mark, you need to refill the brake fluid reservoir.

For easier access to the brake fluid reservoir it is recommended to remove the hexagon screw **4**. Then move the container outwards as indicated in the illustration. Remove plug **5** with rubber boot **6** and add brake fluid DOT 5.1 (Shell Advance Brake DOT 5.1) up to the „MAX“ mark. Replace rubber boot and plug. Overflown or spilled brake liquid must be rinsed off with water. Mount the screw and fix the brake fluid reservoir to the frame, always making sure to prevent kinks in the connecting hose.

⚠ WARNING ⚠

- NEVER USE DOT5 BRAKE FLUID! IT IS BASED ON SILICONE OIL AND OF A PURPLE COLOR. SEALS AND BRAKE HOSES MUST BE ESPECIALLY ADAPTED TO IT.
- STORE BRAKE FLUID OUT OF REACH OF CHILDREN.
- BRAKE FLUID CAN CAUSE SKIN IRRITATION. AVOID CONTACT WITH SKIN AND EYES. IF YOU GET BRAKE FLUID IN YOUR EYES, RINSE WITH PLENTY OF WATER AND CONSULT A DOCTOR

! CAUTION !

- DON'T LET BRAKE FLUID GET IN CONTACT WITH PAINT, IT IS AN EFFECTIVE PAINT REMOVER.
- USE ONLY CLEAN BRAKE FLUID TAKEN FROM A TIGHTLY SEALED CONTAINER.

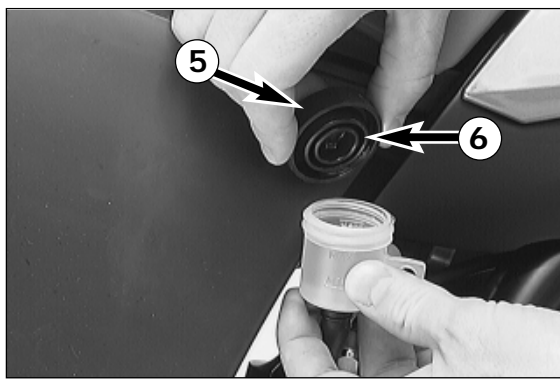

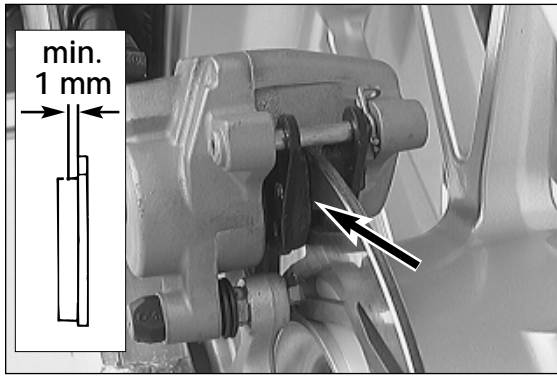

Checking the rear brake pads

The brake pads can be inspected from the rear. The thickness of the linings may not be less than 1 mm (0.04 in).

⚠ WARNING ⚠

AT THEIR MOST WORN POINT BRAKE PAD LININGS SHOULD NOT BE THINNER THAN 1 MM, OTHERWISE THEY COULD LEAD TO BRAKE FAILURE. FOR YOUR OWN SAFETY DON'T PUT OFF HAVING YOUR BRAKE PADS CHANGED.

! CAUTION !

IF THE BRAKE PADS ARE REPLACED TOO LATE SO THAT THE LINING IS PARTLY OR ENTIRELY WORN AWAY, THE STEEL COMPONENTS OF THE BRAKE PAD WILL RUB AGAINST THE BRAKE DISC, IMPAIRING THE BRAKING EFFECT AND DESTROYING THE BRAKE DISC.

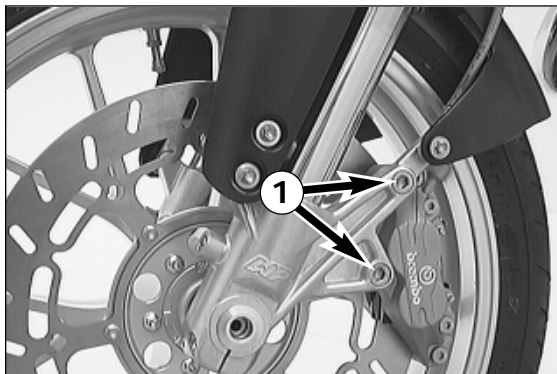

Dismounting and mounting the front wheel*

To remove the front wheel, jack the motorcycle up by the frame so that the front wheel no longer touches the ground. Take out both AH screws **1** and remove brake caliper from brake disc.

! CAUTION !

WHEN REMOVING THE BRAKE CALIPER, MAKE SURE THAT THE BRAKE LINE, THE BRAKE DISC AND THE BRAKE LININGS ARE NOT DAMAGED.

Screw speedometer cable **2** from speedometer drive. Loosen the clamp screws **3** on the right fork leg axle passage (leave the clamp screws on the left fork fist tightened). Loosen wheel spindle **4**. Hold the front wheel, pull the wheel spindle out, remove the front wheel from the fork by pulling it forward.

! CAUTION !

- DO NOT OPERATE THE HAND BRAKE WHEN THE FRONT WHEEL HAS BEEN REMOVED.
- ALWAYS PUT DOWN THE WHEEL WITH THE BRAKE DISC ON TOP TO PREVENT DAMAGING OF THE BRAKE DISC.

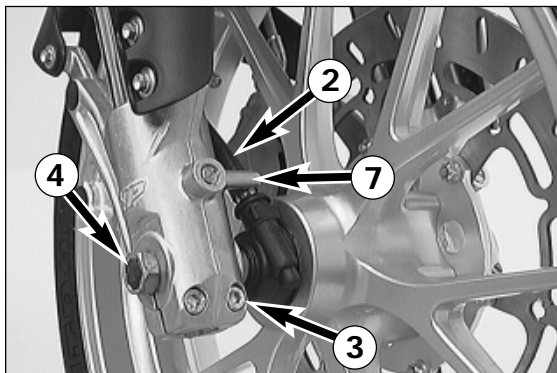

Prior to mounting the front wheel, clean and grease the shaft seal ring **5** and running surface **6** at the speedometer drive.

To mount the front wheel insert speedometer drive into the front wheel. Lift the front wheel into the fork and position the speedometer drive as shown in the illustration (the connection for the speedometer cable must be below the nose **7**).

Replace the wheel spindle and tighten it with 40 Nm (30 ft.lb). Mount the brake caliper, apply Loctite 243 to the thread of the allen head screws and tighten it 45 Nm (33 ft.lb). Attach speedometer drive cable.

Jack the motorcycle back down, work the front brake and bounce the fork hard a few times to align the fork tubes. Now you can tighten the clamp screws on the right fork leg axle passage to 10 Nm (7 ft.lb).

⚠ WARNING ⚠

- THE AH SCREWS **1** OF THE BRAKE CALIPER MUST BE SECURED WITH LOCTITE 243 TO PREVENT LOOSENING.
- IF YOU DON'T HAPPEN TO HAVE A TORQUE WRENCH AT HAND, MAKE SURE YOU HAVE THE TIGHTENING TORQUE CORRECTED BY A KTM DEALER AS SOON AS POSSIBLE.
- IT IS VERY IMPORTANT TO KEEP THE BRAKE DISK FREE FROM OIL AND GREASE, OTHERWISE THE BRAKING EFFECTS WOULD BE STRONGLY REDUCED.
- AFTER MOUNTING THE FRONT WHEEL, KEEP OPERATING THE HAND BRAKE UNTIL THE PRESSURE POINT RETURNS.

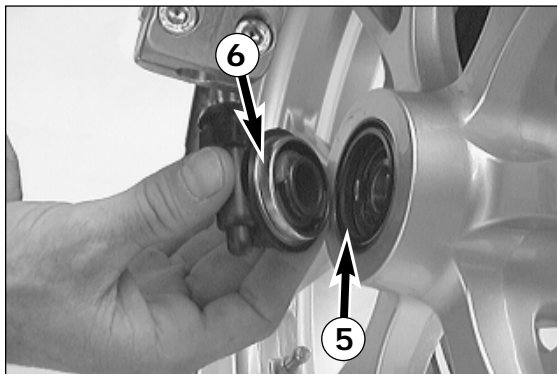

Dismounting and mounting the rear wheel*

Jack the motorcycle up by the frame so that the rear wheel no longer touches the ground.

Loosen the wheel spindle **8**. Holding the rear wheel, remove wheel spindle. Pull down on the rear wheel, pushing it slightly forward and lift the chain from the chain wheel.

! CAUTION !

- DO NOT OPERATE THE FOOT BRAKE WHEN THE REAR WHEEL HAS BEEN DISMOUNTED.
- ALWAYS PUT DOWN THE WHEEL WITH THE BRAKE DISC ON TOP TO PREVENT DAMAGING OF THE BRAKE DISC.

NOTE:
When removing the rear wheel always check the damping rubbers.

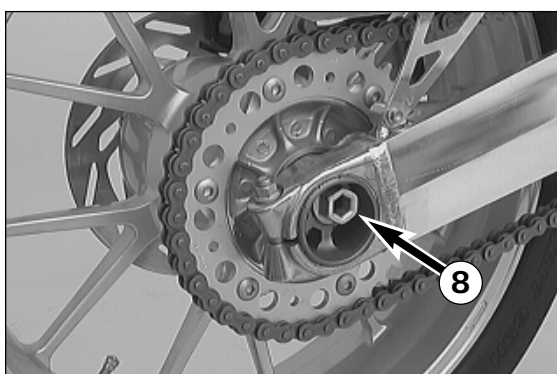

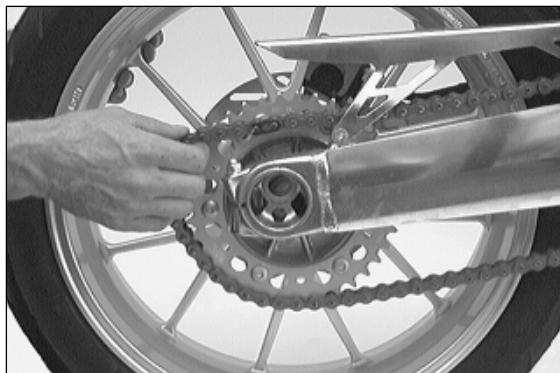

Clean the threads of the wheel spindle and apply grease.
Place rear wheel back in the swing arm together with the rear sprocket carrier and put the chain on the chain wheel.
Insert the brake disc into the caliper and replace wheel spindle.
Tighten wheel spindle to 80 Nm (59 ft.lb).

⚠ **WARNING** ⚠

- IF YOU DON'T HAPPEN TO HAVE A TORQUE WRENCH AT HAND, MAKE SURE YOU HAVE THE TIGHTENING TORQUE CORRECTED BY A KTM DEALER AS SOON AS POSSIBLE.
- IT IS VERY IMPORTANT TO KEEP THE BRAKE DISK FREE FROM OIL AND GREASE, OTHERWISE THE BRAKING EFFECTS WOULD BE STRONGLY REDUCED.
- AFTER MOUNTING THE REAR WHEEL, KEEP OPERATING THE FOOT BRAKE UNTIL THE PRESSURE POINT RETURNS.



Checking the damping rubbers in the rear wheel *

In the Duke, the transmission of power to the rear wheel is damped. For this purpose, the engine power is conveyed from the rear sprocket via 6 damping rubbers ❶ to the rear wheel. These 6 damping rubbers wear with increasing operation time, and should be checked for wear whenever the rear wheel is dismounted.

For this purpose, lie the rear wheel on a work bench with the rear sprocket upwards, and put the wheel spindle in the hub. Now hold the rear wheel firmly and try to turn the rear sprocket. The rear sprocket may not turn more than maximum 5 mm (0,2 in) measured on the outside. If the play in the chain wheel is larger, all 6 shock damping rubbers are to be replaced. Check the shock damping rubbers for signs of damage and dirt.

! **CAUTION** !

IF THE DAMPING RUBBERS ARE NOT REPLACED IN GOOD TIME, THE REAR SPROCKET CARRIER AND THE REAR WHEEL WILL BE DAMAGED.

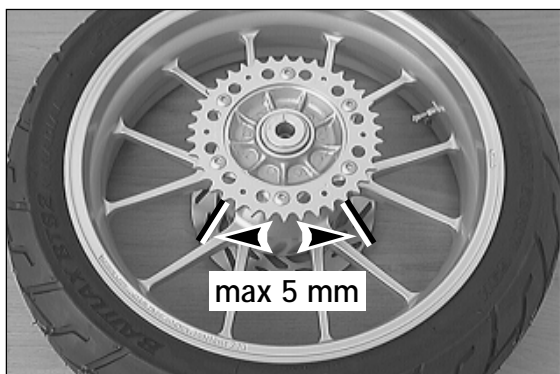

Tires, air pressure

Tire type, tire condition, and how much air pressure the tires have in them affect the way your motorcycle rides, and they must therefore be checked whenever you're getting ready to go anywhere on your motorcycle. Tire type and size can be found in the technical specifications and in the homologation certificate.

Tire condition has to be checked every time you want to ride your motorcycle. Before leaving check for punctures and nails or other sharp objects that might have become embedded in the tire.

Refer to the specific regulations in your country for minimum tire tread requirements. We recommend replacing tires at the latest when the tread is down to 2 mm.

Tire pressure should be checked regularly on a "cold" tire. Proper pressure ensures optimum driving comfort and extends the life of your tires.

⚠ **WARNING** ⚠

- DO NOT MOUNT TIRES WHICH HAVE NOT BEEN APPROVED BY KTM. OTHER TIRES COULD HAVE ADVERSE EFFECTS ON THE WAY YOUR MOTORCYCLE RIDES.
- THE FRONT AND REAR WHEEL ARE ONLY ALLOWED TO BE TIRED WITH TIRES THAT HAVE THE SAME PROFILE TYPE.
- FOR YOUR OWN SAFETY REPLACE DAMAGED TIRES IMMEDIATELY.
- WORN TIRES CAN HAVE A NEGATIVE EFFECT ON HOW YOUR MOTORCYCLE PERFORMS, ESPECIALLY ON WET SURFACES
- IF AIR PRESSURE IS TOO LOW, ABNORMAL WEAR AND OVERHEATING OF THE TIRE CAN RESULT.
- NEW WHEELS HAVE A SMOOTH SURFACE, WHICH MEANS THAT THEY MUST BE RUN IN TO ACHIEVE FULL GRIP. FOR THIS PURPOSE, RIDE THE MOTORCYCLE CAREFULLY AT MODERATE SPEED DURING THE FIRST 200 KILOMETERS WITH NEW TIRES, TILTING THE VEHICLE AT DIFFERENT ANGLES SO THAT ALL SECTIONS ARE PROPERLY ROUGHENED. TIRES WILL NOT DISPLAY THEIR FULL GRIP CHARACTERISTICS UNTIL THEY ARE PROPERLY RUN IN.
- FOR REASONS OF SAFETY, IT IS RECOMMENDED TO EXCHANGE THE VALVE INSERT WHENEVER A NEW TIRE IS MOUNTED.

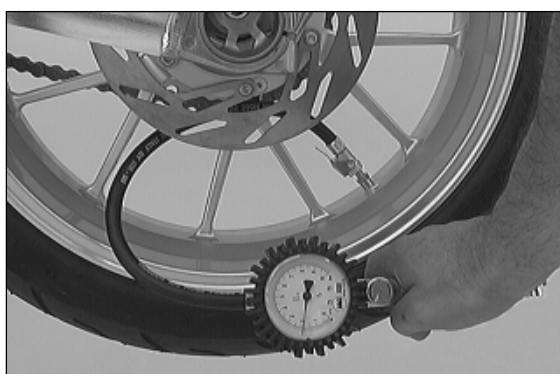

	front tyre air pressure	rear tyre air pressure
operator only	2,0 bar	2,2 bar
operator plus passenger	2,2 bar	2,4 bar



Battery

The battery is mounted under the seat (remove the seat, see page 9)

MAINTENANCE:

The battery has a closed system and therefore requires no maintenance. It is not necessary to check the electrolyte level or to refill water. Simply keep the battery poles clean and slightly grease them with an acid-free grease if necessary.

REMOVING THE BATTERY:

First disconnect the negative and then the positive pole of the battery.

Remove screws ❶ and take off retaining bracket.

Remove battery.

When replacing, connect first the positive and then the negative pole.

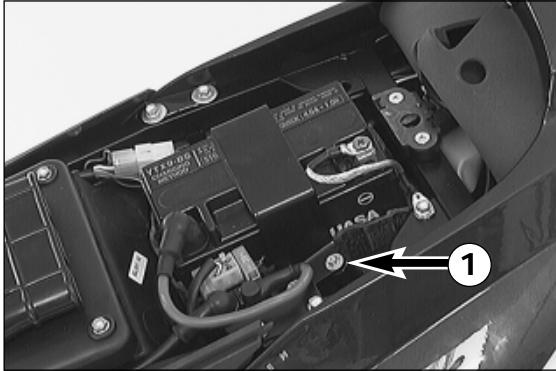

⚠ WARNING ⚠

- IF ELECTROLYTE (SULPHURIC ACID) LEAKS FROM THE BATTERY, PROCEED WITH GREAT CARE. THE ELECTROLYTE CAN CAUSE SEVERE BURNS.
- IN THE CASE OF SKIN CONTACT RINSE THOROUGHLY WITH WATER.
- IN THE CASE OF CONTACT WITH THE EYES, THOROUGHLY RINSE EYES WITH WATER FOR AT LEAST 15 MINUTES. IMMEDIATELY CONSULT A DOCTOR!
- THE BATTERY IS A CLOSED MODEL BUT CAN NEVERTHELESS EMIT EXPLOSIVE GASES. AVOID SPARKS AND OPEN FIRE NEAR THE BATTERY.
- DEFECT BATTERIES MUST BE STORED OUT OF THE REACH OF CHILDREN. ENSURE PROPER DISPOSAL OF DISCARDED BATTERIES.

! CAUTION !

- TO AVOID DAMAGE, DO NOT REMOVE THE LOCKING BAR ❷ !
- NEVER DISCONNECT THE BATTERY WHILE THE ENGINE IS RUNNING. THIS WILL DESTROY THE RECTIFIER-REGULATOR.

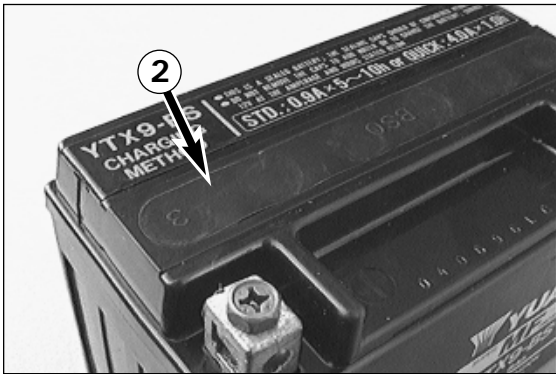

STORAGE:

When preparing the motorcycle for a longer period of standstill, remove the battery and recharge it. Storage temperature: 0 - 35° C. Do not expose to direct sun radiation.

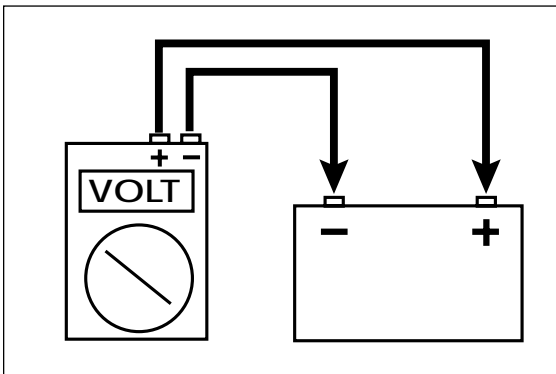

Charging the battery

Remove the battery and check the charging level. Use a voltmeter to measure the voltage between the battery poles (off-load voltage).

Accurate results can only be obtained if the battery has neither been charged nor discharged during a period of 30 minutes preceding the measuring.

off load voltage Volt	charging level %	charging time 0,8 A	charging voltage
>12,7	100	--	max. 14,4 V
~12,5	75	4 h	
~12,2	50	7 h	
~12,0	25	11 h	
~11,8	0	14 h	



If the battery is empty, it can be recharged for a maximum period of 10 hours at 0.8 A and a maximum of 14.4 V.

! CAUTION !

- TO AVOID DAMAGE, DO NOT REMOVE THE LOCKING BAR
- ALWAYS CONNECT THE BATTERY TO THE CHARGING UNIT BEFORE TURNING THE CHARGING UNIT ON.
- WHEN RECHARGING THE BATTERY IN CLOSED ROOMS ENSURE SUFFICIENT VENTILATION. EXPLOSIVE GASES ARE RELEASED DURING THE BATTERY CHARGING PROCESS.
- CHARGING TIME AND CHARGING VOLTAGE SHOULD NOT EXCEED THE STATED VALUES. OTHERWISE ELECTROLYTE WILL BE RELEASED THROUGH THE SAFETY VALVES.
- AVOID QUICK CHARGING IF POSSIBLE.

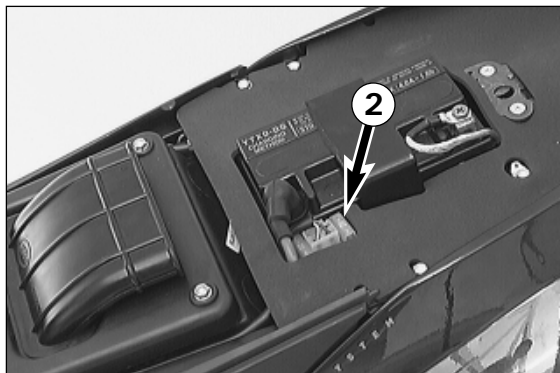

Main fuse

The main fuse ❶ protects all power-consuming units on the motorcycle. It is located below the seat at the starter relay.

For access to the fuse, remove the cover ❷. The capacity of the fuse is 20 A. A spare fuse can be found under the other cover ❸. When using the spare fuse, remember to replace it as soon as possible so that a spare fuse is always at hand.

Replace a blown fuse only with an equivalent one. If a new fuse that has just been set in gets blown again, you are strongly advised to have it inspected by a KTM dealer.

The fuse capacity is 20 Ampere.

! CAUTION !

- UNDER NO CIRCUMSTANCES IS A STRONGER FUSE ALLOWED TO BE SET IN OR A FUSE ALLOWED TO BE "REPAIRED". AN INEXPERT TREATMENT COULD DAMAGE THE WHOLE ELECTRICAL INSTALLATION!
- CONTACT A SPECIALIZED KTM DEALER, SHOULD DEFECTS OF THE ELECTRIC SYSTEM OCCUR MORE FREQUENTLY.

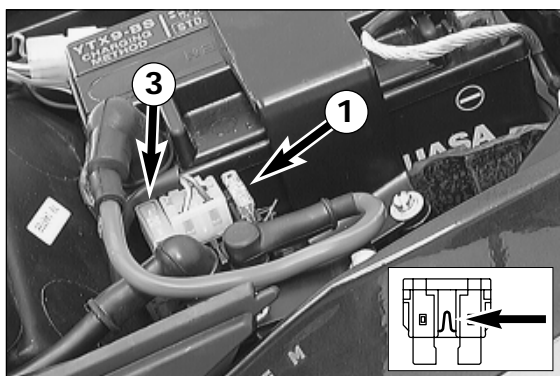

Fuses for individual power-consuming units

Additional fuses separately protecting different power-consuming units are mounted under the headlight mask.

For instructions to remove and mount the headlight mask please refer to "Exchanging the headlight lamp".

Fuse ❹ (10 Ampere) protects the following power-consuming units:

- headlight
- parking light

Fuse ❺ (10 Ampere) protects the following power-consuming units:

- flasher lights
- brake light
- horn
- radiator fan motor

Fuse ❻ (10 Ampere) protects the following power-consuming units:

- ignition
- starter system

Replace a blown fuse only with an equivalent one. If a new fuse that has just been set in gets blown again, you are strongly advised to have it inspected by a KTM dealer.

! CAUTION !

- UNDER NO CIRCUMSTANCES IS A STRONGER FUSE ALLOWED TO BE SET IN OR A FUSE ALLOWED TO BE "REPAIRED". AN INEXPERT TREATMENT COULD DAMAGE THE WHOLE ELECTRICAL INSTALLATION!
- CONTACT A SPECIALIZED KTM DEALER, SHOULD DEFECTS OF THE ELECTRIC SYSTEM OCCUR MORE FREQUENTLY.

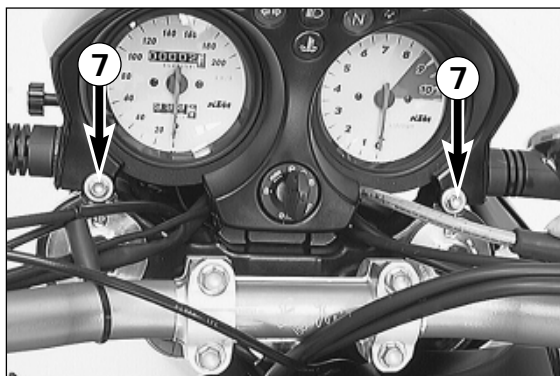
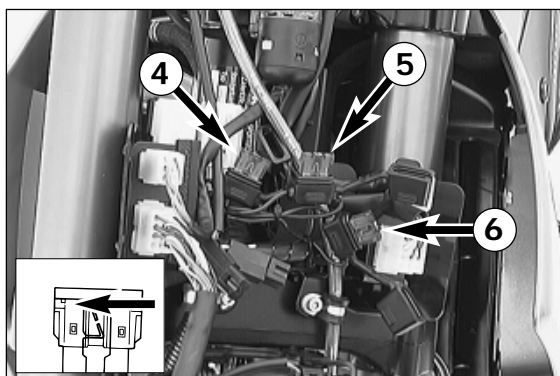

Opening the headlight mask

The headlight mask can be opened, thus providing easy access to headlight lamps, instrument lights, indicator lamps and fuses.

Remove the screws ❷ and take out the ignition key.

Lift the instrument cover in the area of the ignition lock, simultaneously swinging the headlight mask forward.

The headlight mask can be swung forward until it rests against the fork legs. To prevent damaging of painted surfaces, it is recommended to put a cloth or similar material between the mask and the fork legs.



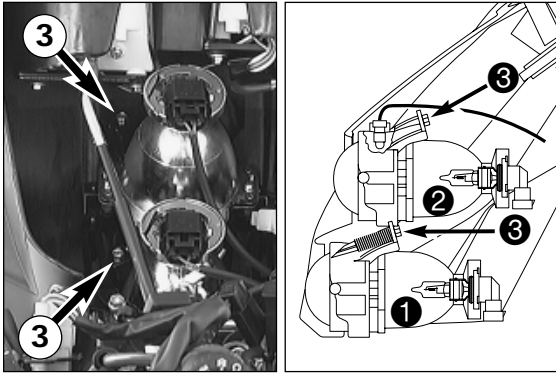

Headlight range adjustment *

The range by the low beam ① and the high beam ② can be adjusted by means of the screws ③.
These screws ③ are accessible when the headlight mask is opened.
Turn the screws clockwise to reduce the distance lighted.
Turn the screws counterclockwise to increase the distance lighted.

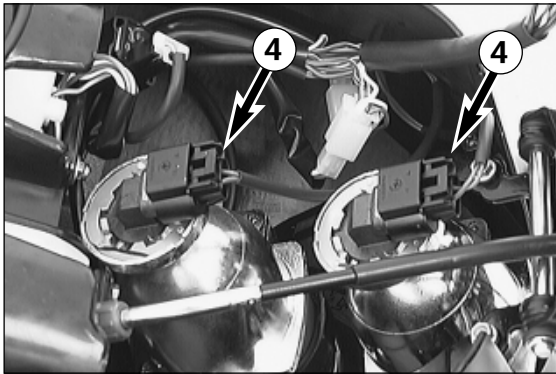

Headlight - replacing the bulbs *

Open the headlight mask.
Take off the cable plug ④.
Turn the bulb ⑤ counterclockwise all the way to the stop, then take it out of the headlight.
The glass bulb and the bulb socket are one single unit. Do not attempt to pull the bulb out of the socket. The lamp is a special bulb (Type HB3) which is not available everywhere. Therefore, always make sure to have a spare lamp with you.
Insert the new bulb into the headlight, avoiding to touch the glass of the bulb with bare fingers.

! CAUTION !

NEVER TOUCH THE GLASS OF THE BULB WITH YOUR FINGERS. THE GLASS OF THE BULB MUST REMAIN ABSOLUTELY FREE FROM GREASE. HEAT WILL OTHERWISE CAUSE THE GREASE TO EVAPORATE AND SETTLE DOWN ON THE REFLECTOR.

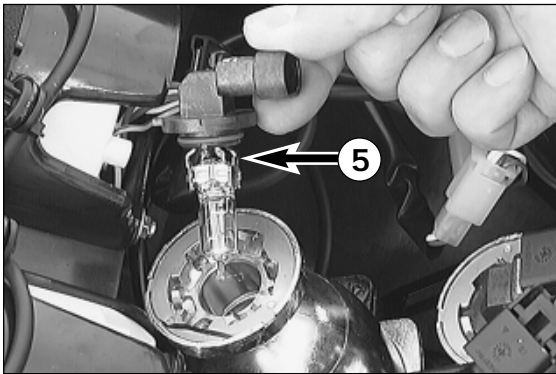

Reconnect the cable plug.
Start the engine and check the headlight for proper functioning.
Close the headlight mask.

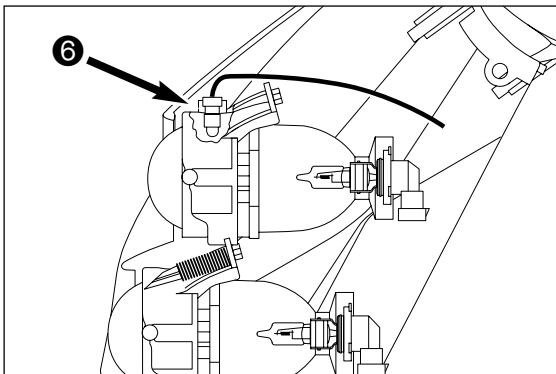

Parking light - replacing the bulb *

The parking light is located in the upper headlight.
Open the headlight mask.
Pull the bulb socket ⑥ upward and out of the headlight.
Pull the old bulb out of the bulb socket and insert a new bulb.

! CAUTION !

NEVER TOUCH THE GLASS OF THE BULB WITH YOUR FINGERS. THE GLASS OF THE BULB MUST REMAIN ABSOLUTELY FREE FROM GREASE. HEAT WILL OTHERWISE CAUSE THE GREASE TO EVAPORATE AND SETTLE DOWN ON THE REFLECTOR.
Check if the lamp works properly.
Reassemble the unit, reversing the worksteps indicated above.

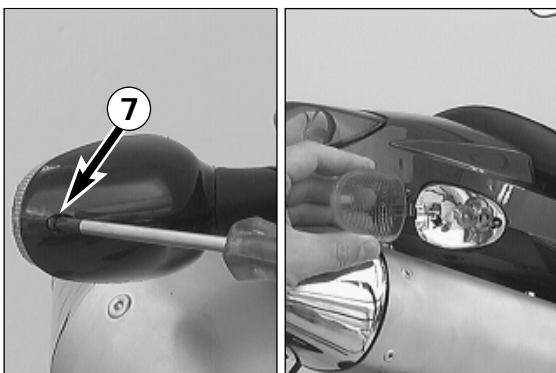

Flasher - replacing the bulbs

Remove screw ⑦ and remove the lens.
Depress the bulb, turn it to the left and pull it out of the bulb socket.
To reassemble the flasher light, reverse the above-described sequence.

Stop light and tail light - replacing the bulb

Remove seat.

Turn the lamp socket ❶ approximately 30° counterclockwise and pull it out of the tail light housing.

Slightly depress the bulb, turn it approx. 30° counterclockwise and pull it out of the socket.

To mount the lamp reverse the worksteps indicated above.

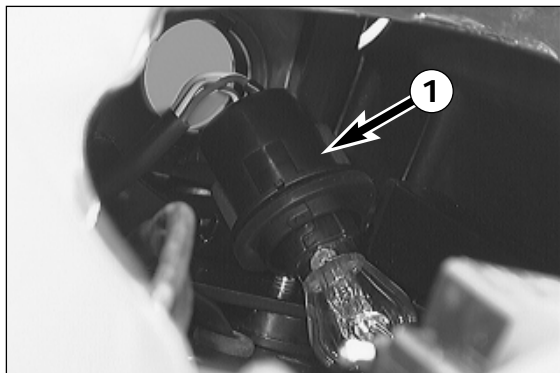

Cooling system

Cooling liquid is circulated by a water pump ❷ located in the engine. When the engine is cold the cooling liquid circulates only through the cylinder and the cylinder head. After the engine has reached its operating temperature (about 70° C, 158° F), the thermostat ❸ opens and the cooling liquid is also pumped through both aluminum radiators.

Air blowing in through the radiators cools the cooling liquid. The slower the speed of the motorcycle, the less the cooling liquid is cooled down. Dirty radiator fins also reduce the cooling efficiency.

If little or no air blows through the radiators, for example when riding through slow traffic or waiting at traffic lights, the cooling liquid temperature will rise. If the cooling liquid temperature rises to 85° C (185° F), the fan on the left radiator will switch on. This fan will provide additional air circulation through the radiator thereby preventing the cooling system from overheating.

Pressure induced by heating of the cooling liquid in the cooling system is controlled by a valve in the radiator cap ❹; a water temperature rising up to 120° C (248° F) is admissible, without fear of problems.

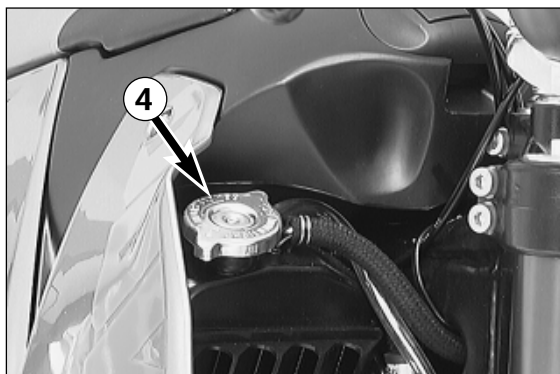
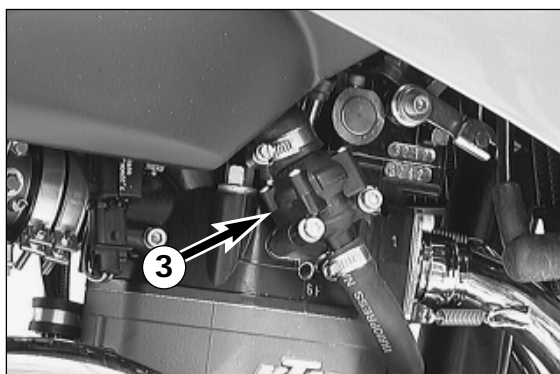
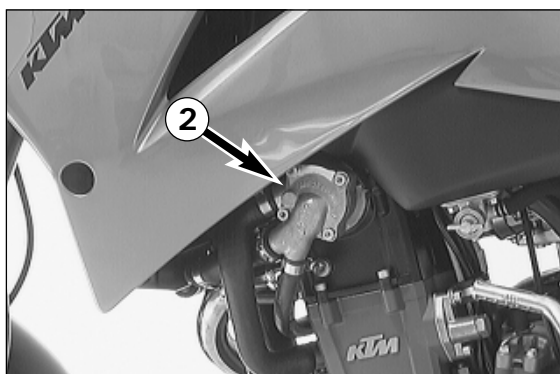

! CAUTION !

IF THE RED COOLING LIQUID TEMPERATURE WARNING LAMP ❺ LIGHTS UP, THIS WILL MOST LIKELY BE DUE TO A DEFECT IN THE COOLING SYSTEM. IN THIS CASE, STOP IMMEDIATELY AND TURN OFF THE ENGINE. LET THE ENGINE COOL DOWN AND CHECK THE COOLING SYSTEM FOR LEAKS. ALSO CHECK IF THERE IS ENOUGH COOLING LIQUID. **CAUTION - SCALDING HAZARD!** DO NOT DRIVE ON, UNTIL THERE IS SUFFICIENT LIQUID IN THE COOLING SYSTEM. HOWEVER, CALL ON ONE OF KTM'S DEALERS AS SOON AS POSSIBLE IN ORDER TO HAVE THE DEFECT REMEDIED. IF YOU DRIVE ON EVEN THOUGH THE WARNING LAMP IS LIT, YOU WILL DAMAGE YOUR ENGINE.

⚠ WARNING ⚠

- IF POSSIBLE, ALWAYS CHECK LEVEL OF COOLING LIQUID WHEN ENGINE IS COLD. IF YOU HAVE TO OPEN THE RADIATOR CAP ❹ WHEN THE ENGINE IS HOT, USE A RAG TO COVER THE CAP AND OPEN SLOWLY TO RELEASE PRESSURE. **CAUTION - SCALDING HAZARD !**
- DO NOT DETACH ANY RADIATOR HOSES WHILE THE ENGINE IS HOT. THE ESCAPING HOT COOLANT AND THE STEAM MAY CAUSE SERIOUS BURNS.
- IN CASE YOU GET BURNT, HOLD THE AFFECTED PART OF YOUR BODY UNDER RUNNING COLD WATER RIGHT AWAY!
- COOLANT IS TOXIC. KEEP THE COOLANT OUT OF THE REACH OF CHILDREN!
- IN CASE COOLANT IS INGESTED, GO SEE A DOCTOR IMMEDIATELY!
- IF COOLANT GETS INTO YOUR EYES, RINSE THEM OUT WITH WATER IMMEDIATELY AND GO SEE A DOCTOR!

A mixture of 40% antifreezer and 60% water is used as cooling liquid. However, the anti-freeze protection must be at least -25° C (-13° F). Aside from antifreezing protection, this mixture also provides great corrosion protection which is why it must not be replaced by pure water.

! CAUTION !

FOR THE COOLING SYSTEM, USE ONLY HIGH-GRADE ANTIFREEZER (SHELL ADVANCE COOLANT). USING LOWERGRADE ANTIFREEZE AGENTS, CAN CAUSE CORROSION AND COOLANT FOAMING.

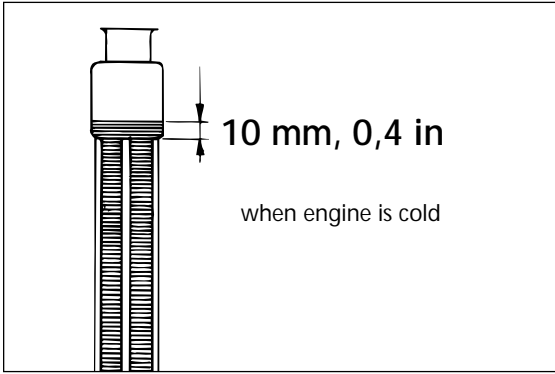

Checking the coolant level

The coolant should be 10 mm (0,4 in) above the radiator fins when the engine is cold (see illustr.). In the event of the coolant being drained, always fill and bleed the system.



WARNING



- IF POSSIBLE, ALWAYS CHECK LEVEL OF COOLING LIQUID WHEN ENGINE IS COLD. IF YOU HAVE TO OPEN THE RADIATOR CAP WHEN THE ENGINE IS HOT, USE A RAG TO COVER THE CAP AND OPEN SLOWLY TO RELEASE PRESSURE. **CAUTION - SCALDING HAZARD !**
- DO NOT DETACH ANY RADIATOR HOSES WHILE THE ENGINE IS HOT. THE ESCAPING HOT COOLANT AND THE STEAM MAY CAUSE SERIOUS BURNS.
- IN CASE YOU GET BURNT, HOLD THE AFFECTED PART OF YOUR BODY UNDER RUNNING COLD WATER RIGHT AWAY!
- COOLANT IS TOXIC. KEEP THE COOLANT OUT OF THE REACH OF CHILDREN!
- IN CASE COOLANT IS INGESTED, GO SEE A DOCTOR IMMEDIATELY!
- IF COOLANT GETS INTO YOUR EYES, RINSE THEM OUT WITH WATER IMMEDIATELY AND GO SEE A DOCTOR!

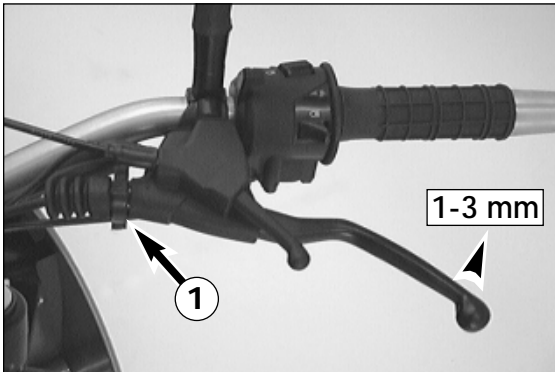

Adjusting the clutch cable

When the engine is cold, the play at the clutch lever should be 1-3 mm (0.04-0.12 in) (measured at the outer edge).

To adjust the clutch cable turn the adjusting nut ❶ accordingly.

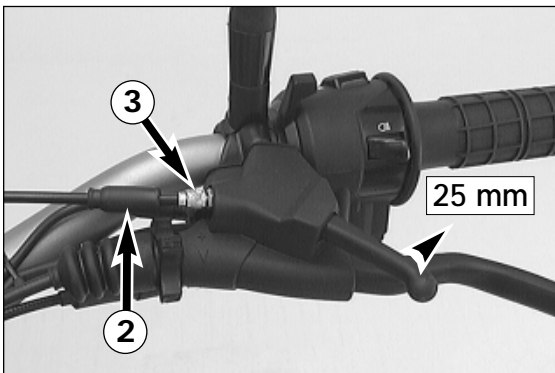

Checking the adjustment of the hand decompression cable *

To check, set piston at compression, so that the valves are closed. While doing this, slowly operate the kick starter until the clicking sound (disengaging) of the automatic decompression release can be heard. Now it must be possible to operate the decompression lever 25 mm (1 in) until resistance is felt (the exhaust valves begin to open). To adjust move back the protective cover ❷, loosen the counter nut and correct the adjusting screw ❸ accordingly. Tighten counter nut and push back protective cover.



CAUTION



IF THERE IS NO PLAY IN THE DECOMPRESSION LEVER, THIS CAN RESULT IN ENGINE DAMAGE.

NOTE:

No adjustment need be made to the automatic decompressor.

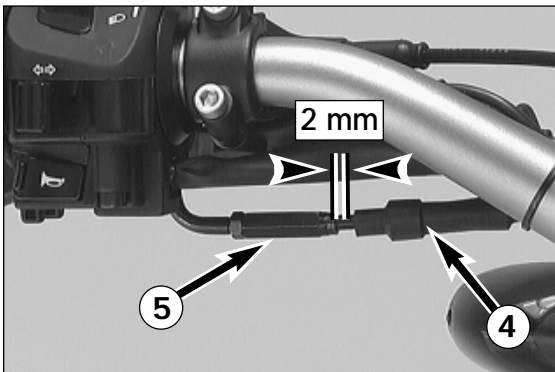

Adjusting the choke cable *

At the choke cable, there must always exist a play of approx. 2 mm (0.1 in). To check this, push choke lever fully forward and pull protective cover ❹ from the adjuster piece ❺. Now, it must be possible to lift the outer covering of the cable by approx. 2 mm from the adjuster piece until feeling a resistance. If necessary, loosen counter nut and readjust play by turning the adjuster piece. Tighten counter nut, and slide on protective cover.

Adjust idling speed *

Use the adjusting screw ❶ to adjust the basic position of the throttle valve and, thus, the idle speed. Turning in clockwise direction will increase the idling speed, turning in counterclockwise direction will reduce the idling speed. Normal idling speed 1400 - 1500 rpm.

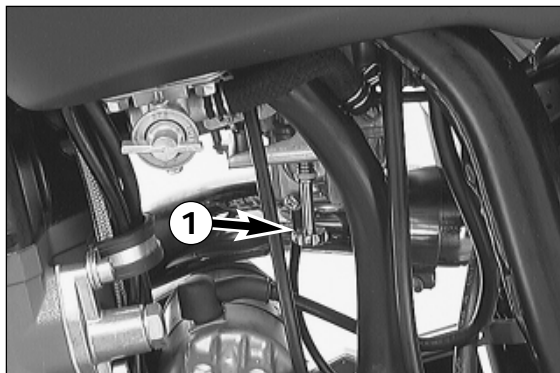

Draining of float chamber of the carburetor

Following every wet-cleaning procedure, the float chamber of the carburetor should be drained in order to remove any water that may have penetrated into it. Water in the float chamber leads to engine malfunction.

Wait until the engine is cold before commencing to perform the worksteps indicated below.

Close the fuel tap.

Put the end of the hose ❷ that leads downward behind the engine into an appropriate container.

Open the drain plug ❸, turning it counterclockwise a few times, and let the fuel drain from the float chamber.

Then tighten the drain plug and open the fuel tap.

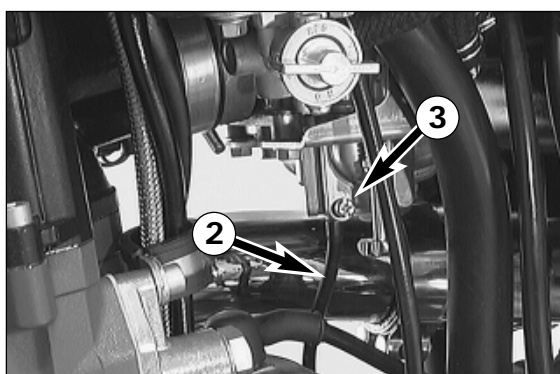
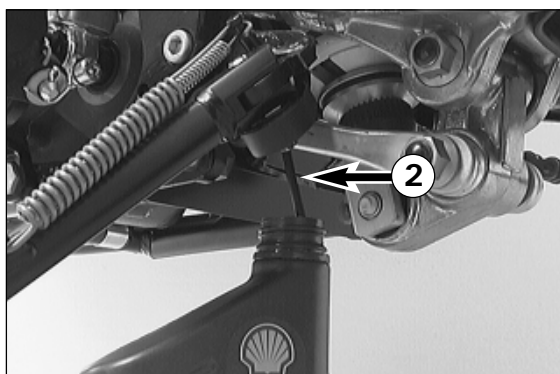

⚠ WARNING ⚠

FUEL IS EASILY FLAMMABLE AND TOXIC. WHEN HANDLING FUEL, BE SURE TO EXERCISE THE UTMOST CAUTION. NEVER PERFORM ANY WORK ON THE FUEL SYSTEM IN THE PROXIMITY OF OPEN FLAMES OR BURNING CIGARETTES. ALWAYS ALLOW THE ENGINE TO COOL OFF FIRST. IMMEDIATELY CLEAN UP ANY FUEL WHICH MAY HAVE BEEN SPILLED. MATERIALS SATURATED WITH FUEL ARE ALSO EASILY FLAMMABLE. IN CASE YOU INGESTED FUEL OR FUEL SPLASHED INTO YOUR EYES, CONSULT A DOCTOR IMMEDIATELY.

Oil circuit

The oil pump ❶ pumps the motor oil past the bypass valve ❷ and through the oil filter ❸. Beyond the oil filter, one of the oil lines forks off to a jet ❹ that injects motor oil to the piston pin bearing and the piston head. The second oil line leads the main oil flow to the frame breast pipe ❺ where the motor oil is cooled off. Then the motor oil flows through the fine screen filter ❻ that removes even the finest of contaminants from the motor oil. The cleansed motor oil is pumped via an oil line and the clutch cover into the crankshaft to the conrod bearing ❼ and drains from there into the crank case. A additional oil pump ❸ suction the motor oil out of the crank case and pumps it through the oil canal ❾ to the gear wheels of the 4th and 5th gears. The motor oil reaches the oil sump via the gear wheels. The timing chain ❿ also dips into the oil sump and propels motor oil upwards to the cylinder head. The motor oil reaches the camshaft ⓫ and the valves through the bore ⓬.

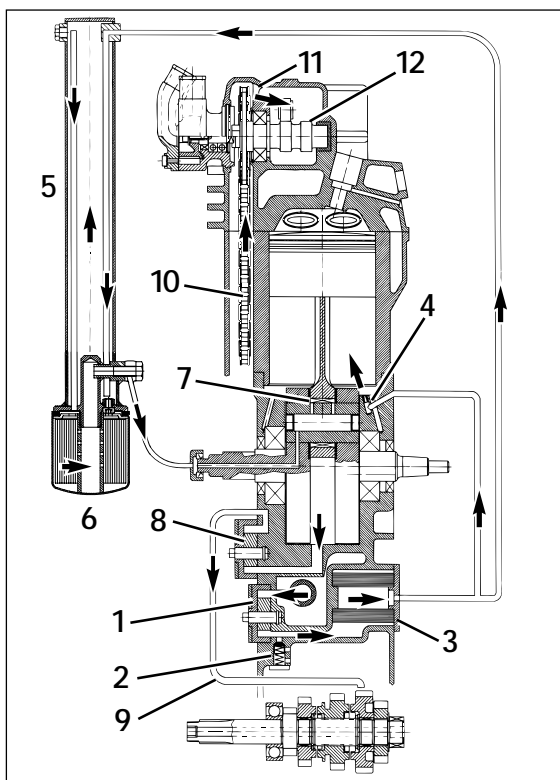

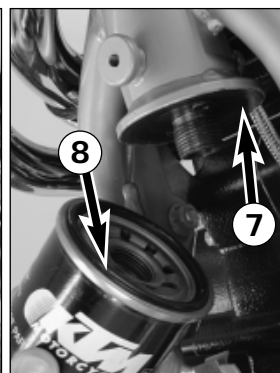
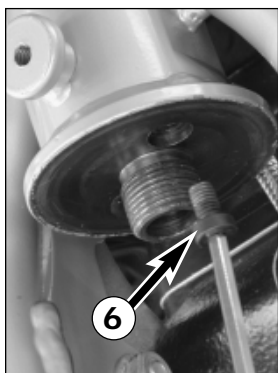
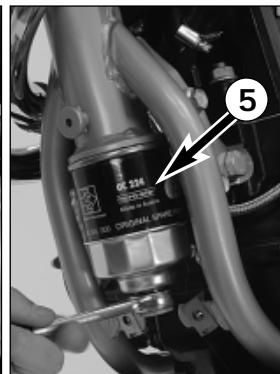
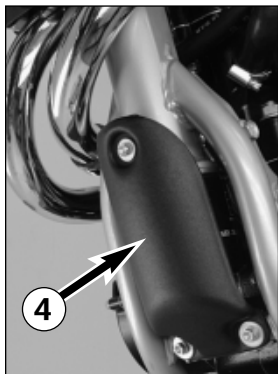
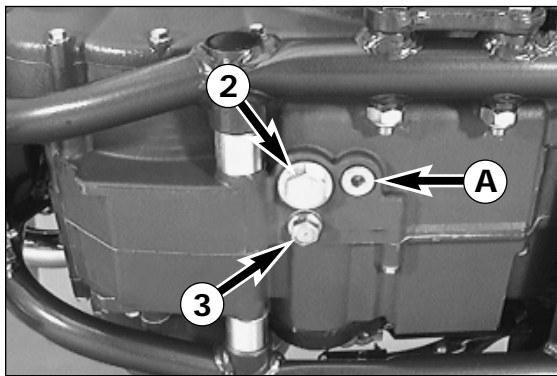
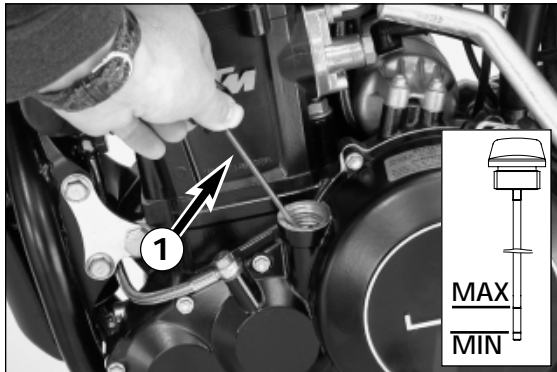
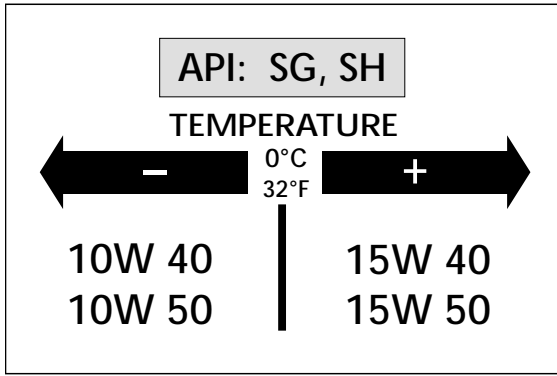

Engine oil

Only use synthetic high-quality oils (Shell Advance Ultra 4) meeting or surpassing the quality requirements of API classes SG, or SH (for specifications see containers).

! CAUTION !

INSUFFICIENT OIL OR POOR QUALITY OIL RESULTS IN PREMATURE WEAR OF THE ENGINE.

Checking the engine oil level

Allow the engine to run at idle speed for about 4 minutes. Turn off the engine and place the motorcycle on a flat, level surface (center stand). Wait 5 minutes, unscrew and remove the oil dipstick ①, and wipe it clean with a cloth.

SCREW THE DIPSTICK IN ALL THE WAY AND REMOVE IT AGAIN.

The oil level should be between the two marks on the dipstick, however, it must never rise above the MAX mark. Otherwise, engine oil would get into the air filter box by way of the engine venting system.

Add engine oil if necessary.

! CAUTION !

- INSUFFICIENT OIL OR POOR QUALITY OIL RESULTS IN PREMATURE WEAR OF THE ENGINE.
- CHECKING THE ENGINE OIL LEVEL WHEN THE ENGINE IS COLD RESULTS IN A FALSE READING ON THE OIL DIPSTICK AND THEREFORE AN INCORRECT OIL LEVEL.
- DO NOT OVERFILL THE ENGINE CASE.
- DO NOT UNDERFILL THE ENGINE CASE.

Finally, check oil system and engine for leaks.

Oil and screen filter change, bleeding of the oil system *

Note: The frame breast pipe is integrated into the oil circuit for the sake of more effectively cooling the motor oil. It is thus important when changing the oil to also remove the fine screen filter, to drain the motor oil from the breast pipe and to de-aerate the oil system.

If the oil system is not bled at all or bled insufficiently, the bearings of the engine will not get enough lubrication, which in turn may result in engine failure.

Therefore, we recommend that you have the engine oil changed by your authorized KTM mechanic. During the guaranty period, the oil change must be performed by an authorized KTM mechanic. Otherwise, the guarantee will become void.

The engine oil change is to be carried out when the engine is still warm.

! WARNING !

AN ENGINE HAVING BEEN RUN WARM, AND THE ENGINE OIL IN IT IS VERY HOT - DO NOT BURN YOURSELF.

Place the motorcycle on a horizontal surface. Remove the two plugs ② and ③, and drain oil into a container.

! CAUTION !

PLUG ① MUST NOT BE REMOVED, THIS IS PART OF THE BY-PASS VALVE.

Remove the screws and the cover ④. Loosen the fine screen filter ⑤ with an oil filter wrench and then screw it off by hand.

The screw ⑥ must be removed to allow the motor oil to flow out of the frame breast pipe.

Clean the plugs thoroughly with petroleum and compressed air in order to remove any metal filings. After the oil has drained completely, clean the sealing areas and remount the plugs together with their gaskets. Tighten plug ② with 30 Nm and plug ③ with 20 Nm. Tighten the screw ⑥ with 10 Nm. Clean sealing surfaces on the frame breast pipe ⑦, fill new fine screen filter with engine oil, and oil rubber gasket ⑧. Replace fine screen filter and screw it back in place, your bare hand will do.

Remove oil dipstick on the clutch cover, fill with 1,3 litre engine oil and attach plug again.

! CAUTION !

- USE ONLY ORIGINAL KTM FINE SCREEN FILTERS. USING ANOTHER FILTER BRAND CAN RESULT IN DAMAGE TO THE ENGINE.
- IF THE ENGINE OIL HAS BEEN DRAINED FROM THE FRONT PIPE OF THE FRAME, YOU MUST BLEED THE OIL SYSTEM !



BLEEDING THE OIL SYSTEM

To facilitate bleeding of the oil system, we have added a hose connection piece and a plastic hose to the set of tools. Take an empty oil can (1 liter) and drill a 7 mm-diameter hole into the lid. Screw the hose connection piece into the lid from the outside, and secure it from the inside with the M8 hexagon nut. Slip the plastic hose onto the hose connection piece, and you will have your filling tool.

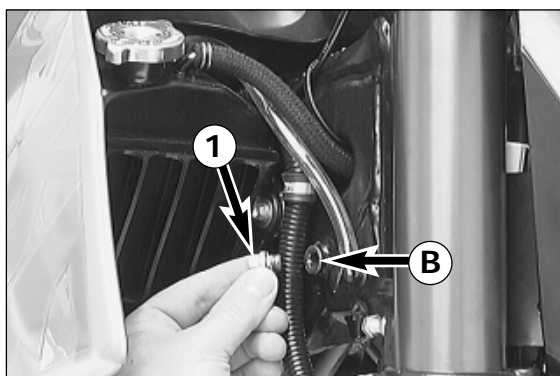

Fill 0.6 liters of engine oil into the can and remove the plug **1** next to the steering head. Introduce the plastic hose into the vent hole **B**, and fill 0.6 liters of engine oil into the frame's front tube. Remove plastic hose, start engine, and let it idle (approx. 20 seconds) until oil escapes at the hole **B**. As soon as oil starts to escape, turn off the engine, and mount the plug together with the gasket.

Allow the engine to run until warm. Then, turn off the engine, and place the motorbike on a flat, level surface in an upright position (center stand). Wait for 5 minutes. Unscrew and remove the oil dipstick, and wipe it clean with a cloth.

SCREW THE DIPSTICK IN ALL THE WAY AND REMOVE IT AGAIN.

The oil level should be between the two marks on the oil dipstick, however, it must never rise above the MAX mark.

Otherwise, engine oil would get into the air filter box by way of the engine venting system.

Add engine oil, if necessary.



- ! CAUTION !**
- INSUFFICIENT OIL OR POOR QUALITY OIL RESULTS IN PREMATURE WEAR OF THE ENGINE.
 - CHECKING THE ENGINE OIL LEVEL WHEN THE ENGINE IS COLD RESULTS IN A FALSE READING ON THE OIL DIPSTICK AND THEREFORE AN INCORRECT OIL LEVEL.
 - DO NOT OVERFILL THE ENGINE CASE.
 - DO NOT UNDERFILL THE ENGINE CASE.

Finally, check oil system and engine for leaks.

NOTE:

DISPOSE OF USED OIL PROPERLY! UNDER NO CIRCUMSTANCES MAY USED OIL BE DISPOSED OF IN THE SEWAGE SYSTEM OR IN THE OPEN COUNTRYSIDE. 1 LITER OIL CONTAMINATES 1.000.000 LITER WATER.

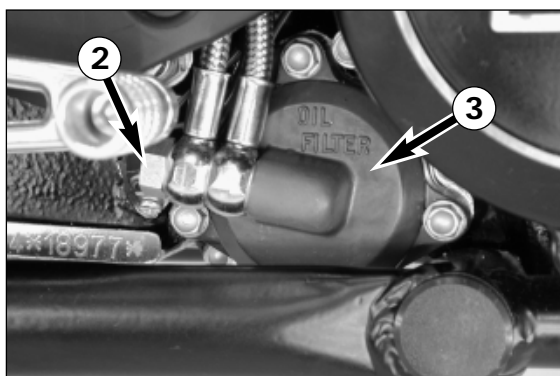

Changing oil filter *

Replace the oil filter when changing the engine oil. Press the foot brake pedal and place a screwdriver or similar between foot brake pedal and stopper roll so that the oil filter cover is more accessible. Remove banjo bolt **2** and the three screws. Remove oil filter cover **3** and oil filter. Clean filter housing, oil filter cover, and sealing surfaces. Check oil duct in oil filter cover if clogged.

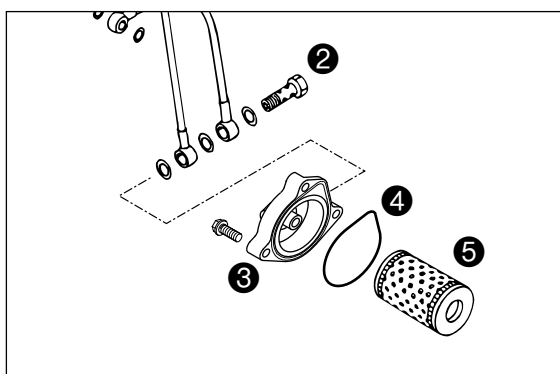

Check the O-ring **4** for damage. O-rings need not be replaced unless damaged. Press the O-ring into the groove of the filter cover. Fit new oil filter **5** with rubber gasket on the fitting in oil filter cover and mount cover with filter. Mount three screws and tighten with 5 Nm (4 ft.lb). Mount hollow screw with seal rings and tighten with 15 Nm (11 ft.lb). Start engine and check oil system for leakage.

TROUBLE SHOOTING

If you let the specified maintenance work on your motorcycle be carried out, disturbances can hardly be expected. Should an error occur nevertheless, we advise you to use the trouble shooting chart in order to find the cause of error. We would like to point out that many operations cannot be performed by oneself. In case of uncertainty, please contact a KTM-dealer.

TROUBLE	CAUSE	REMEDY
Engine doesn't crank.	Operating error	Turn on the ignition, switch the gear to neutral and switch the emergency OFF switch on.
	Discharged battery.	Recharge the battery and investigate the causes for discharging; contact a KTM dealer.
	Defect ignition lock or emergency OFF switch	Check ignition lock and emergency OFF switch, contact a KTM dealer.
The engine doesn't crank. The neutral indicator lamp doesn't light up.	Blown fuse safe-starting system.	Replace fuse (below the headlight mask).
	Blown main fuse.	Remove seat and replace the main fuse. If fuse blows again contact a KTM dealer.
The engine cranks only with pulled clutch lever	Defect safe-starting system.	Contact a KTM dealer.
Engine cranks with gear engaged.	Defect safe-starting system.	Contact a KTM dealer.
Engine cranks but doesn't start.	Operating error	Open fuel tap, tank fuel, you did not use choke i.e. the warm-start device. Pay attention to starting off information (see driving instructions).
	The motorcycle has been out of operation for a longer period of time. Therefore old fuel has accumulated in the float chamber	The easily inflammable components of the new fuels evaporate during longer periods of standstill. When the motorcycle has been out of operation for more than a week, it is therefore recommended to drain the old fuel from the float chamber. The engine will immediately start off when the float chamber is filled with new fuel.
	Fuel supply interrupted	Loosen fuel hose at carburettor, lead into a basin and open fuel tap – if fuel leaks out, the carburetor might need cleaning – if no fuel leaks out, check tank ventilation, i.e. clean fuel tap
	Flooded engine	Fully open the throttle when starting or exchange the spark plug, respectively
	Sooty or wet spark plug	Clean and dry the spark plug or exchange it, respectively
	Electrode gap too large	Adjust spark plug electrode gap to 0,7 mm
	Spark plug connector or spark plug faulty	Dismount spark plug, connect ignition cable, hold to ground (blank place on engine) and actuate starter, a strong spark must be produced at the spark plug – If no spark is created exchange the spark plug. – If the new spark plug doesn't produce a spark either, disconnect the spark plug connector from the ignition cable, hold it a distance of approx. 5 mm from ground and start. – If a spark now occurs, replace spark plug cap – If no spark is produced, control ignition system
	The plug connection of the CDI-unit, the pulse generator or the ignition coil has oxydized	Remove the seat and the fuel tank. Clean the plug connection and treat it with contact spray
Water in carburetor or jets blocked	Dismount and clean carburetor	

TROUBLE	CAUSE	REMEDY
Engine fails to idle	<p>Glogged idling jet</p> <p>Oncorrect adjustment of adjusting screws on carburetor</p> <p>Defective spark plug</p> <p>Defective ignition system</p>	<p>Disassemble carburetor and clean jets</p> <p>Have carburetor adjusted</p> <p>Replace spark plug</p> <p>Have ignition system checked</p>
Engine does not rev high	<p>Carburetor fuel level too high because</p> <p>Float needle is dirty or worn out</p> <p>Float leaks</p> <p>The cold starting system is permanently activated due to a lack of play in the choke cable.</p> <p>Defective membrane of slide</p> <p>Carburetor leaking</p> <p>Loose carburettor jets</p> <p>Electronic ignition timing faulty</p>	<p>Dismount carburetor and check if worn out</p> <p>Replace float needle</p> <p>Replace float</p> <p>Adjust choke cable.</p> <p>Replace membrane</p> <p>Check vacuum hose and venting hoses of carburetor for correct position (no kinks)</p> <p>Tighten jets</p> <p>Have ignition system checked</p>
Engine will not reach full power	<p>Fuel supply partially interrupted or carburetor dirty</p> <p>Float leaks</p> <p>Defective membrane of slide</p> <p>Carburetor leaking</p> <p>Air filter very dirty</p> <p>Valve clearance too small</p> <p>Loss of compression because hand decompressor has no play</p> <p>Electronic ignition timing faulty</p>	<p>Clean and check fuel system as well as carburetor</p> <p>Replace the float</p> <p>Replace membrane</p> <p>Check vacuum hose and venting hoses of carburetor for correct position (no kinks)</p> <p>Clean or replace air filter, contact a KTM dealer</p> <p>Have valve clearance adjusted</p> <p>Check setting of the hand decompression cable</p> <p>Have ignition system checked</p>
Engine overheats	<p>Insufficient cooling liquid</p> <p>Radiator fins are extremely dirty</p> <p>Foam forms in cooling system</p> <p>Bent radiator hose</p> <p>Thermostat defective</p> <p>Blown fan fuse</p> <p>Defect thermostitch</p> <p>Fan defective</p>	<p>Refill cooling liquid (see maintenance work), check cooling system for leaks</p> <p>Clean radiator with water jet</p> <p>Replace cooling liquid, use antifreezer with brand name</p> <p>Shorten or replace cooling hose</p> <p>Remove and check thermostat (opening temperature 70°C (158°F) or replace it, contact a KTM dealer</p> <p>Replace fuse and check if fan operates properly (see below)</p> <p>Contact a KTM dealer</p> <p>Check if fan operates properly. To do this, start the engine, then bypass the connections to the thermostitch (bottom right radiator), contact a KTM dealer</p>

TROUBLE	CAUSE	REMEDY
High oil consumption	Buckling gear ventilation hose Engine oil level too high Engine oil too thin (viscosity)	Readjust or replace ventilation hose Check engine oil level when the engine is warm; correct if necessary Use thicker engine oil; see chapter „Engine oil“
All switched on lamps blown out	Voltage regulator faulty	Remove seat and tank and check connections. Have voltage regulator checked
Headlight and parking light fail	Blown fuse	Replace fuse (below the headlight mask).
Flasher lights, brake light, fan and horn fail	Blown fuse	Replace fuse (below the headlight mask).
The NEUTRAL lamp is not on even though the gear is in NEUTRAL	Defect indicator lamp. Defect neutral switch. Loose connections, defect cable.	Replace bulb Connect cable to ground; neutral switch must be replaced if indicator lamp lights up. Check connections and cables.
The battery is discharged	The ignition (power consumer) hasn't been switched off The battery isn't charged by the generator because	Recharge the battery according to the relevant instructions. Remove seat and tank and check voltage regulator connections; voltage regulator and generator should be checked by a KTM dealer.

CLEANING

Clean your motorcycle regularly in order to keep its painted finish looking shiny and new. The best manner would be to use warm water that has been mixed with a normal trade washing detergent and a sponge. The hard dirt can be removed before with the help of a soft water jet.

!

CAUTION

!

NEVER CLEAN YOUR MOTORCYCLE WITH A HIGH-PRESSURED CLEANER OR A HIGH-PRESSURED WATER JET. THE WATER COULD OTHERWISE RUN INTO THE ELECTRICAL COMPONENTS, CONNECTORS, SHEATHED CABLES, BEARINGS, CARBURETOR ETC. AND CAUSE DISTURBINGS OR LEAD TO A PREMATURE DESTRUCTION OF THESE PARTS.

- You should use normal trade-mark detergents to clean the engine. Strongly dirtied parts should be cleaned additionally with the help of a paint brush.
- Before cleaning with water, plug the exhaust pipe to prevent water ingress
- After the motorcycle has been rinsed with a soft water jet, it should be dried by air pressure and a cloth. Then take a short drive until the engine has reached the working temperature and also use the brakes. Due to the heat, the water also evaporates at the unapproachable parts of the engine and the brakes.
- Slide back the protective covers on the handlebar-mounted instruments so that any water that may have seeped into this part of the motorcycle is allowed to evaporate.
- After the motorcycle has cooled down, oil and grease all sliding and pivot points. Treat the chain with a chain spray too.
- Finally all painted parts should be treated with a gentle paint cleaner.
- To prevent failures in the electric system, you should treat the ignition lock, the emergency off switch, light switch and the socket connectors with contact spray.

CONSERVATION FOR WINTER OPERATION

In the event that the motorcycle is also used in winter and on roads where one has to expect salt spraying, you will have to take precautions against the aggressive road salt.

- clean motorcycle thoroughly and let it dry
- treat engine, carburetor, swing arm, and all other bare or galvanized parts (except for brake discs) with a wax-based anti-corrosion agent.

⚠

WARNING

⚠

KEEP ANTI-CORROSION AGENT FROM GETTING INTO CONTACT WITH THE BRAKE DISCS, FOR OTHERWISE THIS WILL SIGNIFICANTLY REDUCE THE BRAKING POWER.

!

CAUTION

!

AFTER RIDES ON SALTED ROADS, CLEAN MOTORCYCLE THOROUGHLY WITH COLD WATER AND LET IT DRY WELL!

STORAGE

Should you desire to make a pause over a longer space of time, please observe the following instructions:

- Clean motorcycle thoroughly (see chapter: CLEANING)
- Change engine oil, oil filter and fine screen filter (old engine oil contains aggressive contaminations).
- Check antifreezer and amount of cooling liquid.
- Warm up the engine once again, close the fuel tap and wait until the engine dies. Then open the drain plug of the float chamber to remove the remaining fuel.
- Remove spark plug and fill in approx. 5 ccm of engine oil into the cylinder through the opening. Actuate kick-starter 10 times in order to distribute the oil onto the cylinder walls and mount the spark plug.
- Set piston to compression so that the valves will be closed (slowly operate the kickstarter, until you can hear the automatic decompressor click (release))
- Let fuel flow out of tank into an appropriate container.
- Correct tire pressure.
- Lubricate pivot points of the control levers, foot rests, etc. as well as the chain.
- Servicing the shock absorber linkage and swing arm bearings.
- Remove and charge battery (see chapter: BATTERY).
- The storage place should be dry and not subject to excessive temperature fluctuations.
- Cover the motorcycle with an air permeated tarpaulin or blanket. Do not use non air permeable materials as a possible humidity might not be able to escape and could cause corrosion.

!

CAUTION

!

IT IS EXTREMELY BAD TO LET THE ENGINE RUN FOR SHORT PERIODS OF TIME WHEN THE MOTORCYCLE IS KEPT IN STORAGE. SINCE IN THIS CASE THE ENGINE WOULD NOT GET WARM ENOUGH, THE STEAM PRODUCED DURING THE COMBUSTION PROCESS WOULD CONDENSE AND CAUSE RUSTING ON CRANKSHAFT, MAIN BEARING, AND EXHAUST SYSTEM.

RE-INITIATION AFTER TIME OF STORAGE:

- Mount the charged battery (regard polarity).
- Fill up tank with fresh fuel and turn the fuel tap to the ON position.
- Check motorcycle as before each start.
- Take a short, careful test ride first.

NOTE: Before you put your motorcycle away for the winter, you have to check all parts for their function and wear. Should any service jobs, repairs, or any refitting be necessary, you should have them carried out during the off-season (lower workload at mechanics' shops). This way, you can avoid the long waiting times at your mechanic at the beginning of the next biking season.

TECHNICAL DATA – ENGINE 640 DUKE II 2001

Type	640 LC4-E
Design	Liquid-cooled single cylinder 4-stroke engine with balancer shaft and electric starter
Displacement	624,6 ccm
Bore / Stroke	101 / 78 mm
Ratio	11,0 : 1
Fuel	unleaded premium gasoline with a least RON 95
Valve timing	4 valves over rocker arm and 1 overhead camshaft, camshaft drive through single chain
Camshaft	249/1
Valve diameter	Intake: 36 mm Exhaust: 30 mm
Valve clearance cold	Intake: 0.15 mm Exhaust: 0.15 mm
Crank shaft bearing	2 cylinder roller bearing
Connecting rod bearing	needle bearing
Top end bearing	bronze bushing
Piston	forged aluminium alloy
Piston rings	1 compression ring, 1 taper face ring, 1 oil scraper ring
Engine lubrication	2 Eaton-Oilpumps
Quantity of engine oil	see table
Engine oil	2.1 liters including frame
Primary ratio	straight geared spur wheels 30 : 81 teeth
Clutch	multi disc clutch in oil bath
Transmission	5-speed claw shifted
Ignition system	contactless DC- CDI ignition with digital advanced system type KOKUSAN
Ignition timing	adjustment to max. 38° BTDC at 6000 rpm
Generator	12V 200W
Spark plug	NGK DPR8 EA9
Spark plug gap	0.9 mm
Cooling system	liquid cooled, permanent rotation of cooling liquid through mechanic driven water pump
Cooling liquid	1 liter, 40% antifreeze, 60% water, at least -25° C (-13° F)
Starting equipment	electric starter, kick starter

BASIC CARBURETOR SETTING	
	640 DUKE 40 kW
Carburetor	BST40-225
Carburetor setting number	100299
Main jet	145
Needle jet	689 X-6
Idling jet	45
Jet needle	6G5
Needle position from top	3 rd
Mixture.adju. screw open	2,25 turn

#

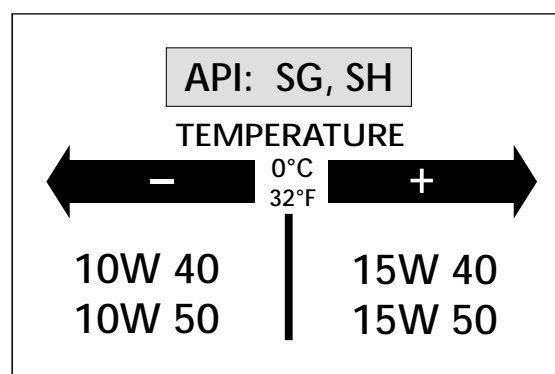

Engine oil

Use only synthetic oil brands (Shell Advance Ultra 4), which meet quality requirements of API-classes SG or SH (informations on bottles) or higher.

! CAUTION !

POOR OIL QUALITY OR MINOR QUANTITY EFFECT EARLY ENGINE-WEAR.

TECHNICAL SPECIFICATIONS - CHASSIS 640 DUKE II 2001

Frame	Central chrome-moly-steel frame
Fork	type WP - USD Roma wheel travel 140 mm (5,5 in) standard adjustment compression driver only = 14, with passenger = 14 standard adjustment rebound driver only = 16, with passenger = 16 fork leg projection upper fork bridge 3 mm (0,12 in) oil capacity per fork leg appr. 400 ccm (24 cubic in) / SAE 5 air chamber lenght 100 mm (4 in)
Rear suspension	WP central shock absorber with PRO-LEVER linkage to rear- swing-arm with needle bearing
Shock absorber	type WP central shock absorber BAVP 118Q785 rear wheel travel 170 mm (6.7 in) standard adjustment compression driver only = 3, with passenger = 5 standard adjustment rebound driver only = 5, with passenger = 3 spring preload driver only = 23 mm (0.9 in), with passenger = 28 mm (1.1 in) spring type 70 - 260
Front brake	Disc brake with carbon-steel brake disc Ø 320 mm (12,6 in) and 4-piston brake caliper
Rear brake	Disc brake with carbon-steel brake disc Ø 220 mm (8,7 in) and single-piston brake caliper floated
Tyres	front: 120/70 R 17 58H rear: 160/60 R 17 69H
Air pressure rider only	2.0 bar (29 psi) 2.2 bar (32 psi)
Air pressure with passenger	2.2 bar (32 psi) 2.4 bar (35 psi)
Fuel tank capacity	11 liter (2,9 US gallons), out of this 2,5 liter (0,6 US gallons) reserve
Final drive ratio	17 : 38
Chain	O-ring 5/8 x 1/4"
Lamps	low beam HB3 12V 65W (socket P20d) high beam HB3 12V 65W (socket P20d) parking light 12V 5W (socket W2,1x9,5d) speedometer, tachometer light 12V 1,2W (socket W2x4,6d) indicator lamp 12V 1,2W (socket W2x4,6d) stop and taillight 12V 21/5W (socket BaY15d) flasher 12V 10W (socket Ba15s)
Battery	maintenance-free battery 12V 8Ah
Steering angle	64,2°
Wheel base	1460 ± 15 mm (57.5 ± 0.6 in)
Seat high	860 mm (33.9 in)
Ground clearance	250 mm (9.9 in)
Dead weight without fuel	145 kg (3 lbs)
Max. permissible front axle load	150 kg (2 lbs)
Max. permissible rear axle load	200 kg (4 lbs)
Max. permissible laden weight	350 kg (773 lbs)

TIGHTENING TORQUES - CHASSIS DUKE II			
Collar nut front axle	M17	40 Nm	(30ft.lb)
Collar nut rear axle	M20x1,5	80 Nm	(59ft.lb)
Shock absorber top	M10	45 Nm	(33ft.lb)
Shock absorber bottom	M10	45 Nm	(33ft.lb)
Collar screws brake disk front	M6	Loctite 243 + 10Nm	(7ft.lb)
Collar screws brake disk rear	M6	Loctite 243 + 10Nm	(7ft.lb)
Screw brake caliper front	M8	Loctite 243 + 25 Nm	(19ft.lb)
Allan head screw brake caliper front	M10x1,25	Loctite 243 + 45 Nm	(33ft.lb)
Allan head screw brake caliper support rear	M10	50 Nm	(37ft.lb)
Bearing bolt linkage arm/frame	M12	60 Nm	(44ft.lb)
Collar nuts rocker arm bolts	M14x1,5	100 Nm	(74ft.lb)
Engine mounting screw	M10	45 Nm	(33ft.lb)
Ball joint for push rod	M8	Loctite 243 + 25 Nm	(19ft.lb)
Sprocket screws on nuts	M8	Loctite 243 + 35 Nm	(25ft.lb)
Collar nut swingarm bolt	M14x1,5	100 Nm	(74ft.lb)
Clamping screws top triple clamp	M8	20 Nm	(15ft.lb)
Clamping screws bottom triple clamp	M8	15 Nm	(11ft.lb)
Clamping screws fork stubs	M8	10 Nm	(7ft.lb)
Collar nut for eccentric chain adjuster	M10	40 Nm	(30ft.lb)
Screws handlebar clamp	M8	Loctite 243 + 20 Nm	(15ft.lb)
Allan head screw handle bar support	M10	Loctite 243 + 40 Nm	(30ft.lb)
Other screws on chassis	M6	10 Nm	(7ft.lb)
	M8	25 Nm	(19ft.lb)
	M10	45 Nm	(33ft.lb)
Other collar nuts on chassis	M6	15 Nm	(11ft.lb)
	M8	30 Nm	(22ft.lb)
	M10	50 Nm	(37ft.lb)

HEAD WORD INDEX

	Page		Page
Adjusting idle speed29	Fuel7
Adjusting the choke cable28	Fuel tap7
Adjusting the clutch cable28	Fuses for individual power-consuming units25
Battery24	General information about KTM disc brakes19
Cassis number4	Hand brake lever5
Chain maintenance19	Hand decompression lever4
Chain wear18	Head word index39
Changing oil filter31	Headlight - replacing the bulbs26
Changing the basic position of the brake pedal21	Headlight range adjustment26
Changing the basic position of the handbrake lever20	Ignition lock with 3 switch position6
Changing the spring preload of the shock absorber17	Ignition lock, with 4 switch position6
Charging the battery24	Important notes1
Checking and adjusting the steering head bearing16	Indicator lamps5
Checking chain tension18	Kickstarter8
Checking of brake fluid level - front brake20	Lubricate rear shock absorber linkage17
Checking the coolant level28	LUBRICATION AND MAINTENANCE SCHEDULE14
Checking the damping rubbers in the rear wheel23	Main fuse25
Checking the engine oil level30	Maintaining chain tension eccentrics19
Checking the front brake pads21	MAINTENANCE WORK ON CHASSIS AND ENGINE16
Checking the rear brake fluid level21	Change oil and fine screen filter, bleeding of the oil system30
Checking the rear brake pads22	Oil circuit29
Checking the rubber ring on the shock absorber17	Opening the head light mask25
Checking the setting of the hand decompression cable28	OPERATION INSTRUMENTS4
Choke lever4	Parking light - replacing the bulb26
CLEANING35	Re-initiation after time of storage35
Clutch lever4	Rebound damping of fork8
Combination switch6	Rebound damping of shock absorber9
Compression damping of fork8	Refilling the front brake fluid reservoir20
Compression damping of shock absorber9	Refilling the rear brake fluid reservoir21
CONSERVATION FOR WINTER OPERATION35	Seat lock9
Consumer information for USA onlyAPPENDIX	SERIAL NUMBER LOCATING4
Cooling system27	Shift lever8
Correcting chain tension18	Speedometer5
Dismounting and mounting the front wheel22	Stop light and tail light - replacing bulb27
Dismounting and mounting the rear wheel22	STORAGE35
Draining of float chamber of the carburetor29	Supporting strap for the passenger9
DRIVING INSTRUCTIONS10	Tachometer5
Emergency OFF button6	TECHNICAL SPECIFICATIONS - CHASSIS37
Emergency OFF switch (Australia)7	TECHNICAL SPECIFICATIONS - ENGINE36
Engine number, engine type4	Tires, air pressure23
Engine oil30	Tool kit16
Filler cap7	TROUBLE SHOOTING32
Flasher - replacing the bulbs26	Wiring diagramappendix
Foot brake pedal8		



KTM SPORTMOTORCYCLE AG
5230 Mattighofen
Austria
Internet: www.ktm.at



320599