



SERVICE

Modell DUKE 2001

Kabelstrangnummer cockpit 587 11 082 000
Kabelstrangnummer vorne 587 11 075 000
Kabelstrangnummer hinten 587 11 076 100

Land DIV LÄNDER

Datum, Name 15 03 00 KE

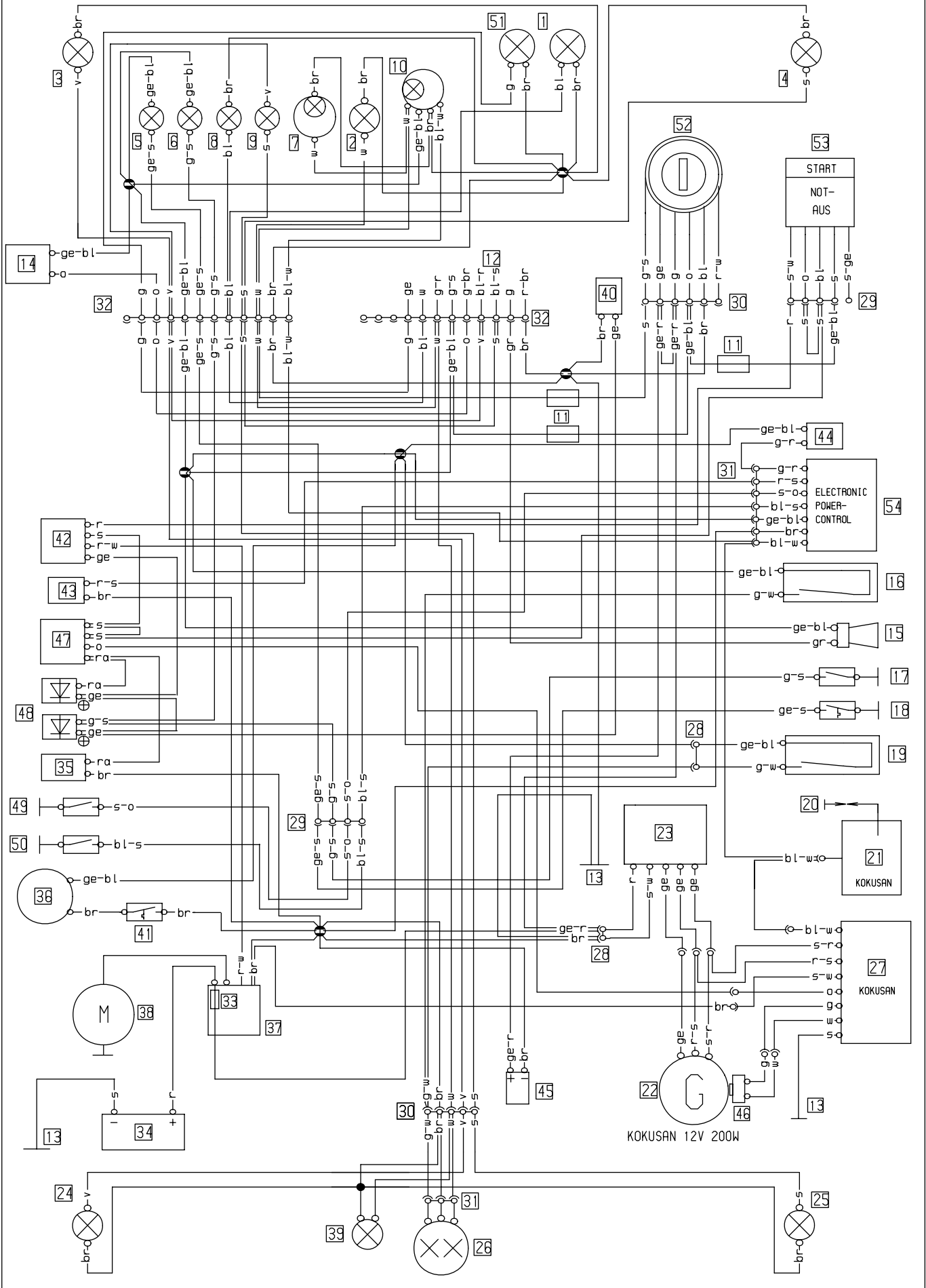

Deutsch	Englisch	Italienisch	Französisch
1 Fernlicht	1 headlight	1 faro	1 phare
2 Standlicht	2 parking light	2 luce di posizione	2 feu de position
3 Blinker li vo	3 blinker left front	3 lampegg ant sn	3 clignoteur av gauche
4 Blinker re vo	4 blinker right front	4 lampegg ant dx	4 clignoteur av droit
5 Temperaturkontrolle	5 temperature control	5 controllo temperatura	5 témoin de température
6 Leerlaufanzeige	6 neutral	6 indicat marcia folle	6 ind de point mort
7 Tachobeleuchtung	7 tachometer light	7 luce di tachimetro	7 éclair comp vitesse
8 Fernlichtkontrolle	8 high beam control	8 spia abbagliante	8 témoin de feu route
9 Blinkerkontrolle	9 blink control	9 spia lampeggiatori	9 témoin de clignoteur
10 Drehzahlmesser	10 tachometer	10 contagiri	10 compte-tours
11 Sicherung 10A	11 fuse 10A	11 fusibile 10A	11 fusible 10A
12 zum Kombischalter	12 to combinat switch	12 multicomando	12 vers commutateur
13 Masseanschluß	13 ground connection	13 collegam a massa	13 masse
14 Blinkgeber	14 blink signal system	14 trasmett di lampeg	14 centrale clignot
15 Horn	15 horn	15 clacson	15 klaxon
16 Bremslichtsch vo	16 stoplight switch f	16 int luce arresto ant	16 cont av de stop
17 Leerlaufschalter (N)	17 idle switch (N)	17 interr luce folle (N)	17 contact pt mort (N)
18 Thermo schalter	18 temperature switch	18 int temperatura	18 contact de température
19 Bremslichtsch hi	19 stoplight switch r	19 int luce arresto post	19 contact arr de stop
20 Zündkerze	20 spark plug	20 candela	20 bougie
21 Zündspule	21 ignition coil	21 bobina d'accens	21 bobine d'allumage
22 Generator	22 generator	22 dinamo	22 generateur
23 Regelgleichrichter	23 regulator-rectifier	23 regolatore di tens	23 regulat redresseur
24 Blinker li hi	24 blinker left rear	24 lampegg post sn	24 clign arr gauche
25 Blinker re hi	25 blinker right rear	25 lampegg post dx	25 clign arr droit
26 Brems-Schlußlicht	26 rear-stoplight	26 fanal post di freno	26 feu arr et de stop
27 CDI-Einheit	27 CDI-unit	27 CDI-seatola	27 boitier CDI
28 2-pol Stecker	28 multip cont plug (2)	28 connettore a 2 poli	28 connect multiple (2)
29 4-pol Stecker	29 multip cont plug (4)	29 connettore a 4 poli	29 connect multiple (4)
30 6-pol Stecker	30 multip cont plug (6)	30 connettore a 6 poli	30 connect multiple (6)
31 3-pol Stecker	31 multip cont plug (3)	31 connettore a 3 poli	31 connect multiple (3)
32 12-pol Stecker	32 multip cont plug (12)	32 connettore a 12 poli	32 connect multible (12)
33 Hauptsicherung 20A	33 mainfuse 20A	33 fusibile principale 20A	33 fusible principal 20A
34 Batterie 12V 8Ah	34 battery 12V 8Ah	34 batteria 12V 8Ah	34 batterie 12V 8Ah
35 Seitenständerschalter	35 sidestandswitch	35 int del cavalletto later	35 commut de bequille later
36 Lüftermotor	36 fan motor	36 ventilatore	36 ventilateur
37 Startrelaise	37 starter relay	37 rele d'avviamento	37 relaise de demarreur
38 Startermotor	38 starter engine	38 mot d'avviamento elettr	38 demarreur electrique
39 Kennzeichenbel	39 licence pl lighting	39 illuminat de targa	39 ecl plaque d'immat
40 Kupplungsschalter	40 clutch switch	40 interruttore frizione	40 contact de embrayage
41 Thermo schalter	41 temperature switch	41 int temperatura	41 contact de température
42 Starterhilfsrelaise	42 startor auxil relay	42 rele avviam ausiliario	42 relaise auxil demarrage
43 Vergaserschalter	43 carburetor switch	43 interruttore carburatore	43 contact de carburateur
44 Magnetventil	44 magnetic valve	44 valvola elettromagnetica	44 electrovanne
45 Kondensator	45 capacitor	45 condensatore	45 condensateur
46 Impulsgeber	46 pulser coil	46 trasmettitore d'impulsi	46 capteur
47 Seitenständerrelais	47 sidestand relay	47 rele del cavalletto later	47 relaise com de bequ lat
48 Diode	48 diode	48 diodo	48 diode
49 Kontaktstift 3 Gang	49 gear switch 3rd gear	49 3 secondo marcia	49 cont d boîte d vites 3
50 Kontaktstift 2 Gang	50 gear switch 2th gear	50 2 secondo marcia	50 cont d boîte d vites 2
51 Abblendlicht	51 low beam	51 anabbaglianti	51 feu de croisement
52 Zündschloß	52 ignition switch	52 interruttore accensione	52 contact d'allum
53 Starttast Notaussch	53 run-off / start switch	53 disinseritor / partire	53 bout de demar/arr d'urg
54 EPC	54 EPC	54 EPC	54 EPC

Spanisch	Deutsch	Englisch	Italienisch	Französisch	Spanisch
1 fero	19 interruptor luz de freno tras	37 rele de arranque			
2 luz de posicion	20 bujia	38 motor de arranque			
3 interm izquierdo delantero	21 bobina de encendido	39 luz placa de matricula			
4 intermitente derecho delantero	22 generador	40 interruptor de embraque			
5 control temperatura	23 regulador de tension	41 interruptor temperatura			
6 indicador punto muerto	24 intermitente izquierdo trasero	42 rele del arranque			
7 luz tacometro	25 intermitente derecho trasero	43 interruptor de carburador			
8 lampara aviso luces largas	26 luz de freno trasero	44 valvola magnetica			
9 lampara aviso intermitentes	27 unidad cdi	45 condensador			
10 cuentarrevoluciones	28 conecdor multiple (2)	46 generado de impulsos			
11 fusible 10A	29 conector multiple (4)	47 rele del caballete lateral			
12 interruptor combinado	30 conector multiple (6)	48 diodo			
13 conector a masa	31 conector multiple (3)	49 interruptor de cambio 3			
14 conjunto del intermitente	32 conector multible (12)	50 interruptor de cambio 2			
15 claxon	33 fusible principal 20A	51 luces de crule			
16 interruptor	34 bateria 12V 8 Ah	52 llave de contacta			
17 interruptor punto muerto	35 int delcaballete lateral	53 boton de arranque par de urg			
18 interruptor temperatura	36 ventilador electrica	54 EPC			

Deutsch	Englisch	Italienisch	Französisch	Spanisch
bl blau	bl blue	bl blu	bl bleu	bl azul
br braun	br brown	br marrone	br brun	br marron
ge gelb	ge yellow	ge giallo	ge jaune	ge amarillo
gr grau	gr grey	gr grigio	gr gris	gr gris
g grün	g green	g verde	g vert	g verde
o orange	o orange	o arancione	o orange	o naranja
r rot	r red	r rosso	r rouge	r rojo
ra rosa	ra pink	ra rosa	ra rose	ra rosado
s schwarz	s black	s nero	s noir	s negro
v violett	v violet	v violetto	v violet	v violeta
w weiß	w white	w bianco	w blanc	w blanco

