

OWNER'S MANUAL 2008

690 DUKE

ART. NO. 3211248en



KTM

DEAR KTM CUSTOMER

Congratulations on your decision to purchase a KTM motorcycle. You are now the owner of a state-of-the-art sports motorcycle that will give you enormous pleasure if you service and maintain it accordingly.

We wish you great pleasure riding the vehicle!

Enter the serial numbers of your vehicle below.

Chassis number/type label (☛ P. 16)	Dealer's stamp
Engine number (☛ P. 17)	
Key number (☛ P. 16)	

The owner's manual corresponded to the latest state of this series at the time of printing. However, it is never possible to exclude small deviations arising from further development in design and construction.

All specifications are not binding. KTM Sportmotorcycle AG in particular reserves the right to modify or delete technical specifications, prices, colors, forms, materials, services, designs, equipment, etc., without prior notice and without specifying reasons, to adapt these to local conditions, as well as to stop production of a particular model without prior notice. KTM accepts no liability for delivery options, deviations from illustrations and descriptions, as well as printing and other errors. The models portrayed partly contain special equipment that does not belong to the regular scope of delivery.

© 2007 by KTM-Sportmotorcycle AG, Mattighofen Austria

All rights reserved

Reproduction, even in part, is permitted only with the express written permission of the copyright owner.



ISO 9001(12 100 6061)











Within the meaning of the international quality management standard ISO 9001, KTM uses quality assurance processes that lead to the maximum possible quality of the products.











Issued by: TÜV Management Service

REG.NO: 12 100 6061

KTM-Sportmotorcycle AG
5230 Mattighofen, Austria

MEANS OF REPRESENTATION	6	Setting the clock	28
IMPORTANT NOTES	7	Combination instrument - ODO display	29
VIEW OF VEHICLE	12	Combination instrument - setting/resetting TRIP 1 display....	29
View of vehicle, front left side.....	12	Combination instrument - setting/resetting TRIP 2 display....	30
View of vehicle, rear right side	14	Combination instrument - TRIP F display	31
LOCATION OF SERIAL NUMBERS	16	Combination instrument - coolant temperature indicator	31
Chassis number/type label.....	16	Opening filler cap.....	32
Key number	16	Closing filler cap	32
Engine number.....	17	Fuel taps	33
Fork part number.....	17	Handrails.....	33
Shock absorber part number.....	18	Seat lock	34
OPERATING ELEMENTS	19	OWNER'S MANUAL.....	34
Clutch lever	19	Tool set	35
Hand brake lever	19	Passenger footrests.....	35
Light switch	20	Shift lever.....	36
Headlight flasher switch.....	20	Foot brake pedal	37
Flasher switch	21	Side stand	37
Horn	21	TIPS ON PUTTING INTO OPERATION	38
Ignition/steering lock	22	Advice on first use.....	38
Emergency OFF switch.....	22	Running in the engine.....	39
Electric starter button	23	Loading the vehicle	40
Combination instrument.....	23	RIDING INSTRUCTIONS	42
Combination instrument - function buttons	24	Checks before putting into operation	42
Combination instrument - tachometer.....	24	Starting.....	43
Combination instrument - control lamps	25	Starting up	45
Combination instrument - Display	26	Shifting, riding.....	45
Combination instrument - speed display	27	Braking	48
Setting kilometers or miles.....	27	Stopping, parking.....	49
Combination instrument - time	28	Refueling.....	51

GREASING AND SERVICE TABLE	53	Brake linings.....	73
Important maintenance work to be carried out by an authorized KTM workshop.	53	Checking the front brake linings.....	74
Important maintenance work to be carried out by an authorized KTM workshop. (as additional order).....	55	Checking free play of foot brake lever	75
MAINTENANCE WORK ON CHASSIS AND ENGINE.....	56	Checking rear brake fluid level.....	75
Jacking up front of motorcycle	56	Topping up brake fluid of front brake 	76
Taking front from work stand	56	Checking rear brake linings	78
Jacking up rear of motorcycle	57	Removing front wheel 	78
Take the rear from the work stand.	57	Fitting front wheel 	80
Fork/shock absorber.....	58	Removing rear wheel 	81
Adjusting compression damping of fork	58	Fitting rear wheel 	82
Adjusting rebound damping of fork.....	59	Checking the rear hub rubber dampers 	84
Compression damping of shock absorber.....	60	Tire condition checking.....	85
Adjusting the low-speed compression damping of the shock absorber	60	Checking tire air pressure.....	86
Adjusting high-speed compression damping of the shock absorber	61	Removing the seat.....	87
Adjusting rebound damping of the shock absorber	62	Mounting the seat	87
Bleeding fork legs.....	63	Reinstalling the fuel tank	88
Checking chain dirt	64	Positioning the fuel tank	89
Cleaning the chain.....	64	Removing the battery 	90
Checking the chain tension	65	Installing the battery 	92
Adjusting chain tension.....	66	Recharging the battery 	94
Checking rear sprocket / engine sprocket for wear	68	Changing the main fuse	96
Checking chain wear.....	69	Changing fuses of individual power consumers	97
Checking brake discs	70	Adjusting the engine characteristics	99
Adjusting basic position of handbrake lever.....	71	Removing headlight mask with headlight	101
Checking brake fluid level of front brake	71	Refitting the headlight mask with the headlight.....	103
Topping up brake fluid of front brake 	72	Changing the low beam bulb.....	104
		Changing the high beam bulb	106
		Changing the parking light bulb	108
		Changing the flasher bulb	109

Checking the low beam headlight adjustment.....	110	STORAGE	145
Checking the high beam headlight adjustment	111	Storage.....	145
Adjusting the light range of the low beam headlight.....	112	Putting into operation after storage	146
Adjusting the light range of the high beam headlight	114	TECHNICAL DATA - ENGINE	147
Cooling system	116	Capacity - engine oil	148
Checking antifreeze and coolant level	116	Capacity - coolant.....	148
Checking the coolant level.....	119	TECHNICAL DATA - ENGINE TIGHTENING TORQUES.....	149
Draining coolant 	120	TECHNICAL DATA - CHASSIS	152
Filling/bleeding the cooling system 	121	Lighting equipment	153
Adjusting basic position of clutch lever.....	123	Capacity - fuel.....	154
Checking/correcting fluid level of hydraulic clutch	124	TECHNICAL DATA - FORK.....	155
Checking play in gas Bowden cable	124	TECHNICAL DATA - SHOCK ABSORBER	156
Adjusting play in gas Bowden cable 	125	TECHNICAL DATA - CHASSIS TIGHTENING TORQUES	158
Adjusting the handlebar angle 	126	SUBSTANCES.....	162
Checking engine oil level.....	126	AUXILIARY SUBSTANCES.....	165
Changing engine oil and oil filter, cleaning oil screens 	127	STANDARDS.....	167
Draining engine oil 	127	INDEX	168
Removing the oil filter 	129		
Mounting oil filter 	131		
Cleaning oil screens 	131		
Filling up with engine oil 	133		
Topping up engine oil	134		
TRUBLESHOOTING.....	136		
FLASHING CODE	139		
CLEANING.....	142		
Cleaning motorcycle	142		
CONSERVE FOR WINTER OPERATION.....	144		
Conservation for winter operation	144		

Symbols used

The symbols used are explained in the following.



Indicates an expected reaction (e.g. of a work step or a function).



Indicates an unexpected reaction (e.g. of a work step or a function).



All work marked with this symbol requires specialist knowledge and technical understanding. In the interest of your own safety, have these jobs done in an authorized KTM workshop! There, your motorcycle will be serviced optimally by specially trained experts using the specialist tools required.



Identifies a page reference (more information is provided on the specified page).

Formats used

The typographical and other formats used are explained in the following.

Eigenname

Indicates a proprietary name.

Name[®]

Identifies a protected name.

Marke[™]

Identifies a brand in merchandise traffic.

Use definition

KTM sport motorcycles are designed and constructed to meet the normal demands of regular road operation but not for use on race courses or offroad.



Info

The motorcycle is authorized for public road traffic in the homologous version only.

Maintenance

A prerequisite for perfect operation and prevention of wear is that the engine and chassis maintenance and adjustment work described in the owner's manual are properly carried out. Poor adjustment and tuning of the engine and chassis can lead to damage and breakage of components.

Using the motorcycle in extreme conditions such as very muddy or wet roads can lead to above-average wear of components such as the transmission train or the brakes. For this reason, it may be necessary to service or replace worn parts before the limit specified in the greasing and service table is reached.

Pay careful attention to the prescribed running-in period, inspection and maintenance intervals. If you observe these exactly, you will ensure a much longer service life for your motorcycle.

Warranty

The maintenance work prescribed in the greasing and service table must be carried out in an authorized KTM workshop and confirmed in the customer's service record, since otherwise no warranty claims will be recognized. No warranty claims can be considered for damage resulting from manipulations and alterations to the vehicle.

Fuel, oils, etc.

You should use the fuels, oils and greases according to specifications as listed in the owner's manual.

Spare parts, accessories

For your own safety, use only spare parts and accessories approved by KTM, and have these mounted only in an authorized KTM workshop. KTM accepts no liability for other products and any resulting damage or loss.

For the latest **KTM PowerParts** for your vehicle, see International KTM Website: <http://www.ktm.com>

Transport

Note

Danger of damage Danger of damage by the vehicle running away or falling over.

- Always place the vehicle on a firm and even surface.

Note

Fire hazard Some components (engine, radiator and exhaust system) get very hot when the engine is running.

- Do not place the vehicle where there are flammable or explosive substances.

- Switch off the engine and remove the ignition key.
- Use straps or other suitable devices to secure the motorcycle against accidents or falling over.

Environment

Offroad motorcycling is a wonderful sport and we naturally hope that you will be able to enjoy it to the fullest. However, it is a potential problem for the environment and can lead to conflicts with other persons. But if you use your motorcycle responsibly, you can ensure that such problems and conflicts do not have to occur. To protect the future of motorcycle sport, make sure that you use your motorcycle legally, display environmental consciousness, and respect the rights of others.

Warning notes

In your own interest, read the specified warning notes.



Info

Various warning labels are attached to your vehicle. Do not remove any warning labels. If they are missing, you or others may not recognize dangers and may therefore be injured.

Grades of risks



Danger

Danger that leads immediately and certainly to severe and permanent injury or death.



Warning

Danger that will probably lead to severe and permanent injury or death.



Caution

Danger that could possibly lead to slight injuries.

Note

Danger of serious damage to machine or material.



Warning

Risk of environmental damage.

OWNER'S MANUAL

- Read this owner's manual carefully and completely before making your first trip. It contains a lot of information and tips to help you operate and handle your motorcycle. Only then will you find out how to customize the motorcycle ideally for your own use and how you can protect yourself from injury. The owner's manual also contains important information on servicing the motorcycle.

- The owner's manual is an important component of the motorcycle and should be handed over to the new owner if the vehicle is sold.

View of vehicle, front left side



1	Combination instrument
2	Rear mirror
3	Clutch lever
4	Seat
5	Handrail
6	Front brake caliper
7	Left fuel tap
8	Shift lever
9	Engine number
10	Side stand

View of vehicle, rear right side

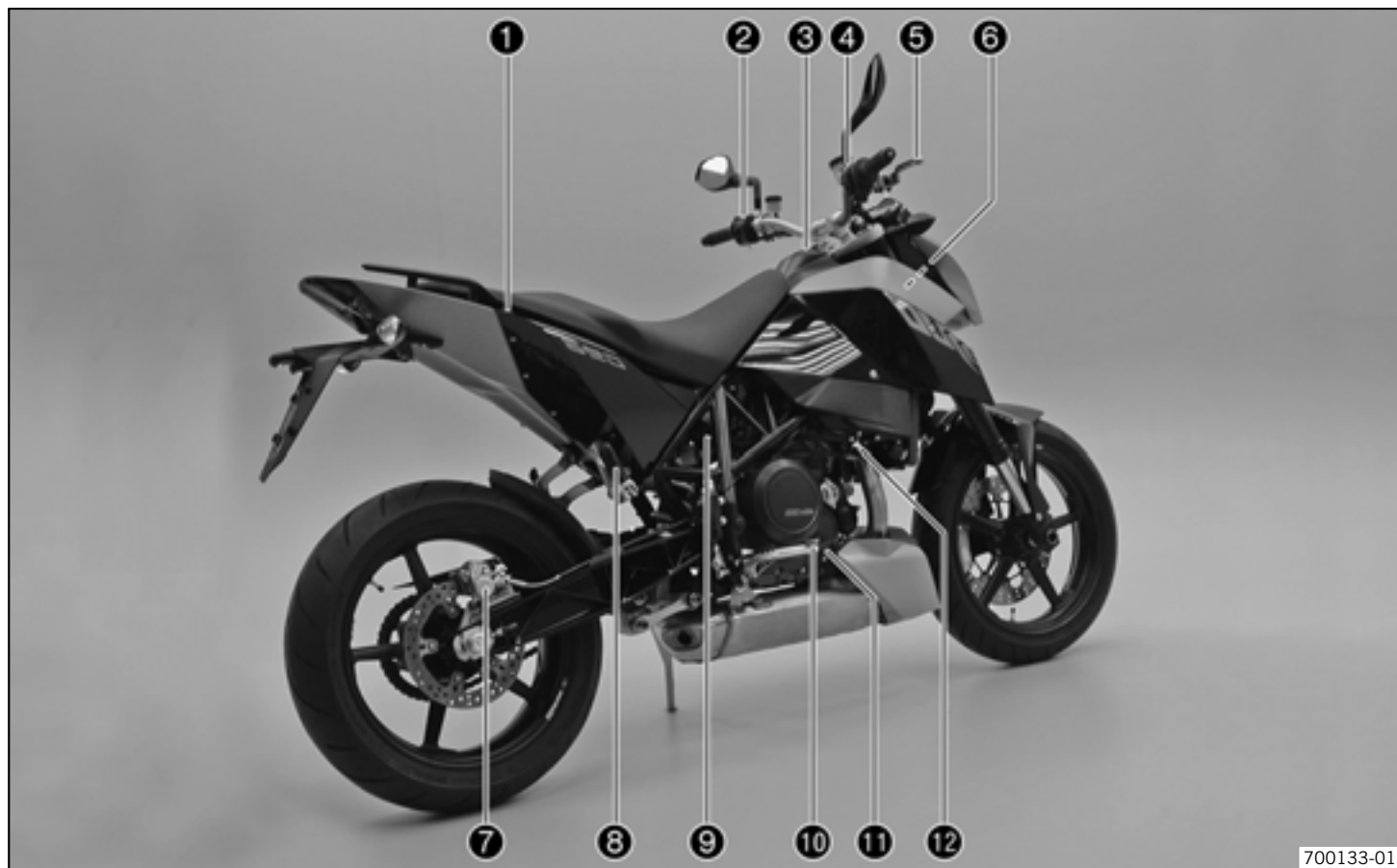

1	Seat lock
2	Light switch, headlight flasher switch, indicator switch, horn
3	Filler cap
4	Emergency OFF switch, electric starter button
5	Hand brake lever
6	Chassis number, type label
7	Rear brake caliper
8	Passenger footrests
9	Map-Select Switch
10	Foot brake pedal
11	Engine oil level viewer
12	Right fuel tap

Chassis number/type label

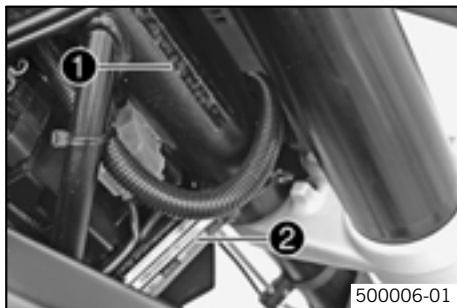

The chassis number ❶ is stamped on the steering head on the right.
The type label ❷ is located under the chassis number.

Key number

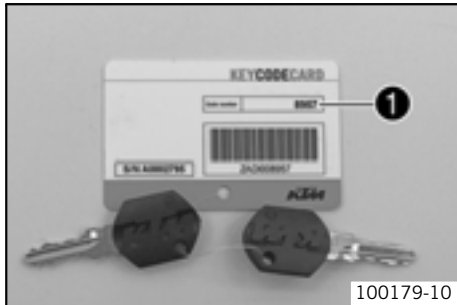

The key number ❶ can be found on the **KEYCODECARD**.



Info

You need the key number to order a spare key. Keep the **KEYCODECARD** in a safe place.

Engine number

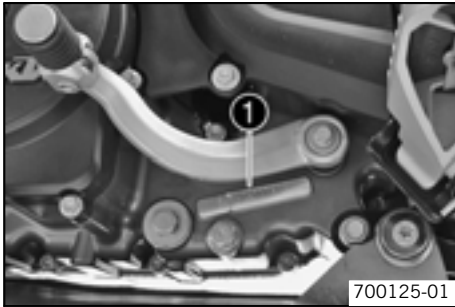

The engine number ❶ is stamped on the left side of the engine under the engine sprocket.

Fork part number

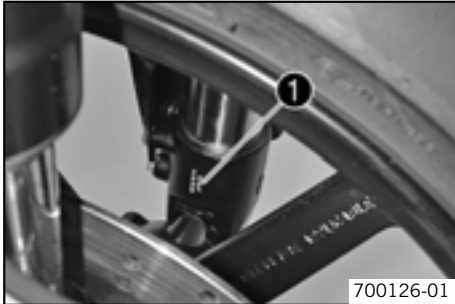

The fork part number ❶ is stamped on the inner side of the fork stub.

Shock absorber part number

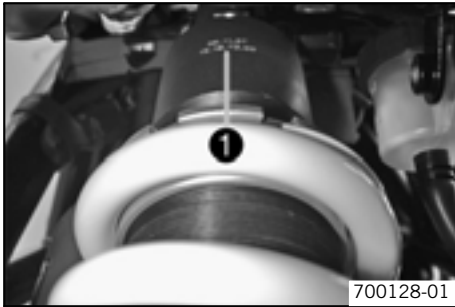

700128-01

The shock absorber part number ❶ is stamped on the top of the shock absorber above the adjusting ring toward the rear.

Clutch lever

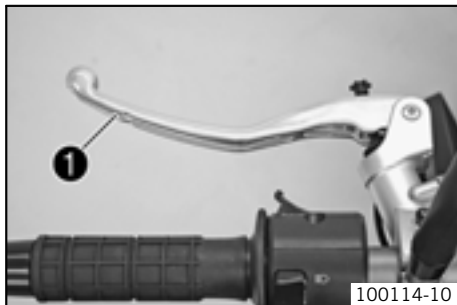

The clutch lever ❶ is fitted on the left side of the handlebar.
The clutch is hydraulically operated and self-adjusting.

Hand brake lever

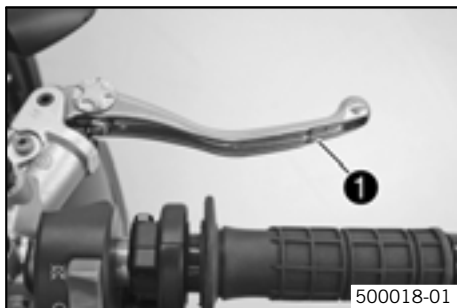

The hand brake lever ❶ is located on the right side of the handlebar and operates the front wheel brake.
The hand brake lever operates the front brake.

Light switch

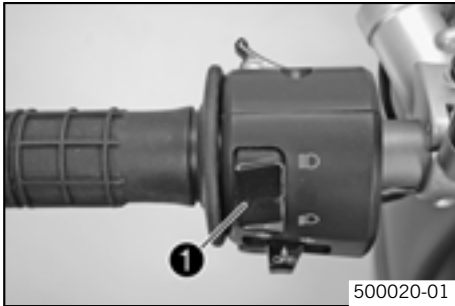

The light switch ❶ is fitted on the left side of the handlebar.

Possible states



Low beam on – Light switch is turned downwards. In this position, the low beam and tail light are switched on.



High beam on – Light switch is turned upwards. In this position, the high beam and the tail light are switched on.

Headlight flasher switch

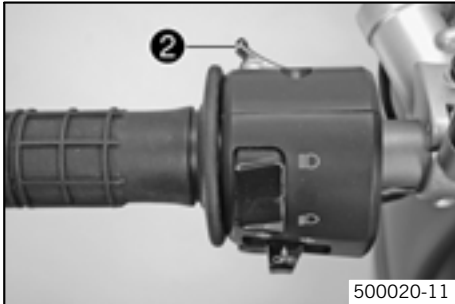

The headlight flasher switch ❷ is fitted on the left side of the handlebar.

Possible states

- Headlight flasher switch in neutral position
- Headlight flasher switch pressed – In this position, the headlight flasher (high beam) is actuated.

Flasher switch



500021-10

The flasher switch ❶ is fitted on the left side of the handlebar.

Possible states

Flasher light off



Flasher light, left, on – Flasher switch pressed to the right. The flasher switch returns automatically to the central position after use.



Flasher light, right, on – Flasher switch pressed to the right. The flasher switch returns automatically to the central position after use.

To switch off the flasher light, press the flasher switch towards the switch case.

Horn

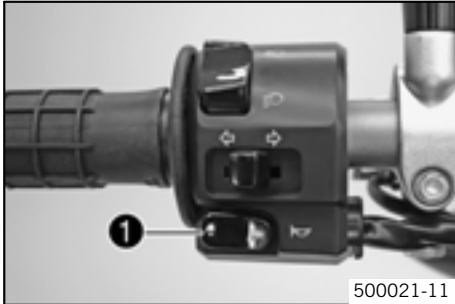

500021-11

The horn button ❶ is fitted on the left side of the handlebar.

Possible states

- Horn button ❶ in neutral position
- Horn button ❶ pressed – The horn is operated in this position.

Ignition/steering lock



The ignition/steering lock ❶ is located in front of the upper triple clamp.

Possible states



Ignition off – In this position, the ignition circuit is interrupted, a running engine stops, and a non-running engine will not start. The ignition key can be removed.



Ignition on – In this position, the ignition circuit is closed, and the engine can be started.



Steering locked – In this position, the ignition circuit is interrupted and the steering locked. The ignition key can be removed.

Emergency OFF switch

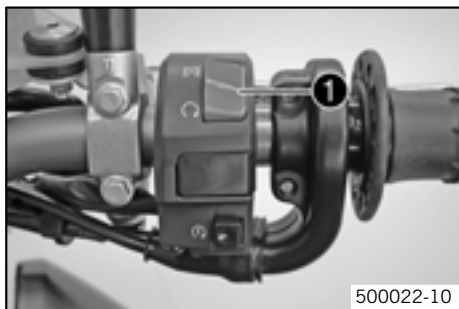

The emergency OFF switch ❶ is fitted on the left side of the handlebar.

Possible states



Emergency OFF switch on – This position is necessary for operation as the ignition circuit is closed.



Emergency OFF switch off – In this position, the ignition circuit is interrupted, a running engine stops, and the engine cannot be started.

Electric starter button

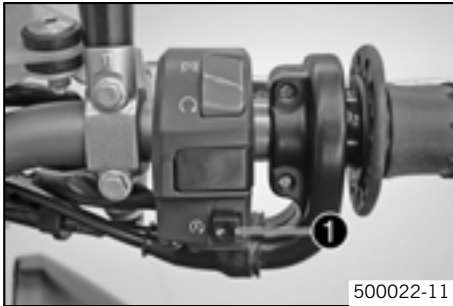

The electric starter button ❶ is fitted on the right side of the handlebar.

Possible states

- Electric starter button ❸ in basic position
- Electric starter button ❸ pressed – In this position, the electric starter is actuated.

Combination instrument

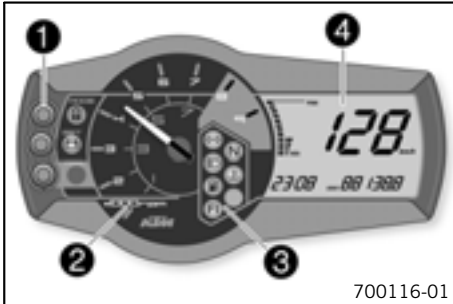

The combination instrument is attached in front of the handlebar.

The combination instrument is divided into 4 function areas.

- ❶ Function buttons
- ❷ Tachometer
- ❸ Indicator lights
- ❹ Display

Combination instrument - function buttons

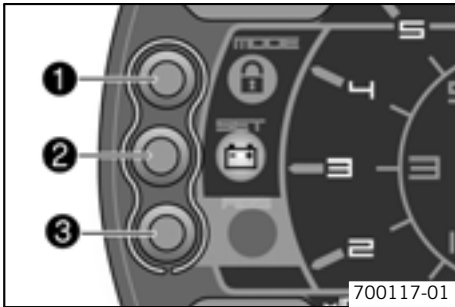

Press the **MODE** button ❶ to change the display mode.

Possible display modes are total distance covered (**ODO**), tripmaster 1 (**TRIP 1**) and tripmaster 2 (**TRIP 2**).

Press the **SET** button ❷ to reset tripmaster 1 (**TRIP 1**) and tripmaster 2 (**TRIP 2**) to **0.0**.

Button ❸ has no function.

Combination instrument - tachometer



The tachometer ❶ displays the engine speed in revolutions per minute.

The red marking ❷ shows the excess engine speed range.

Combination instrument - control lamps



100119-10

The indicator lamps provide additional information on the operating state of the motorcycle.

Possible states



Flashing indicator flashes green in flash rhythm – Flasher light is switched on.



Idling speed indicator lamp lights up green – Transmission is in neutral.



High beam indicator lamp lights up blue – High beam is switched on.



Temperature warning lamp lights up red – Coolant has reached a critical value.



Fuel level warning lamp lights up orange – Fuel level has reached the reserve mark. Display switches to **TRIP F**.



FI warning lamp (**MIL**) lights/flashes orange – The OBD has detected an emission- or safety-critical error.



Battery warning lamp lights up – Voltage in electrical system too low.

Combination instrument - Display



When you switch on the ignition, all display segments light up for a second as a function test.

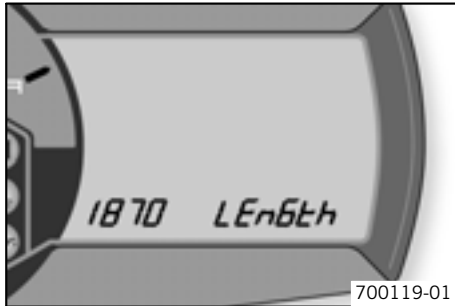

LEnGth

Following the display function test, the wheel circumference **LEnGth** is shown for one second.



Info

1870 mm corresponds to the circumference of the 17" front wheel with a series production tire.

The display then changes to the last selected mode.

Combination instrument - speed display

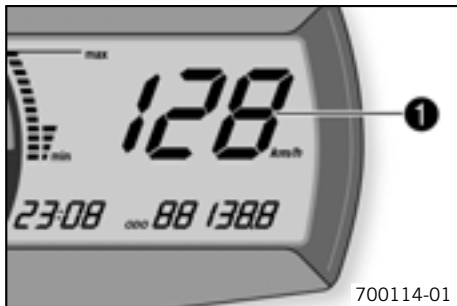

The speed ❶ is displayed in kilometers per hour **km/h** or miles per hour **Mph**.

Setting kilometers or miles



Info

If you change the unit, the **ODO** value is retained and converted accordingly.
Making the setting according to the country.

Condition

The motorcycle is standing.

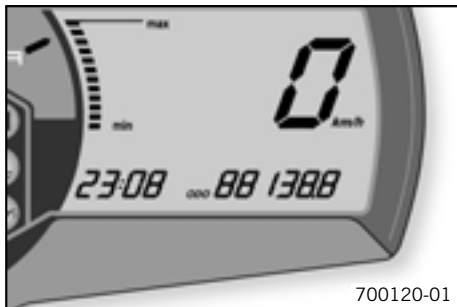

- Turn the ignition key to the position \odot .
- Press the **MODE** button several times until the **ODO** display mode is active.
- Keep the **MODE** button pressed until the display mode changes from **Km/h** to **Mph** or from **Mph** to **Km/h**.

Specification

Activation duration of MODE button	10 s
---	------

Combination instrument - time



The time is shown in area ❶ of the display.



Info

The time must be adjusted after the battery is disconnected or the fuse is changed.

Setting the clock

Condition

The motorcycle is standing.

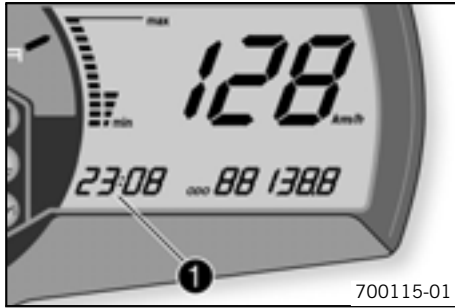

- Turn the ignition key to the position \odot .
- Press the **MODE** button several times until the **ODO** display mode is active.
- Keep the **MODE** button and the **SET** button pressed simultaneously.
 - ✓ The time begins to flash.
- Press the **MODE** button to adjust the hour.
- Press the **SET** button to adjust the minute.
- Keep the **MODE** button and the **SET** button pressed simultaneously.
 - ✓ The time is set.

Combination instrument - ODO display

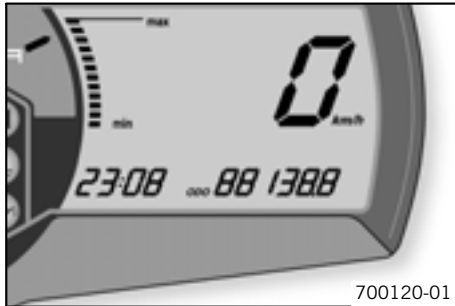

In **ODO** mode, the total distance covered is shown in kilometers or miles.



Info

This value remains intact even if the battery is disconnected and/or the fuse blows.

Combination instrument - setting/resetting TRIP 1 display



Info

The tripmaster **TRIP 1** operates constantly and counts up to **999.9**.

You can use the tripmaster to measure trips or the distance between refuelling stops. After reaching **999.9**, the tripmaster begins again at **0.0**.

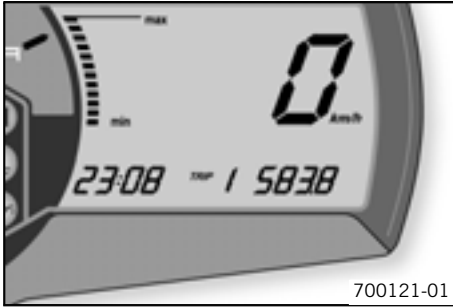

- Turn the ignition key to the position \odot .
- Press the **MODE** button several times until the **TRIP 1** display mode is active.
- Keep the **SET** button pressed.
- ✓ The **TRIP 1** display is at **0.0**.

Combination instrument - setting/resetting TRIP 2 display

Info

The tripmaster **TRIP 2** operates constantly and counts up to **999.9**.

You can use the tripmaster to measure trips or the distance between refuelling stops. After reaching **999.9**, the tripmaster begins again at **0.0**.

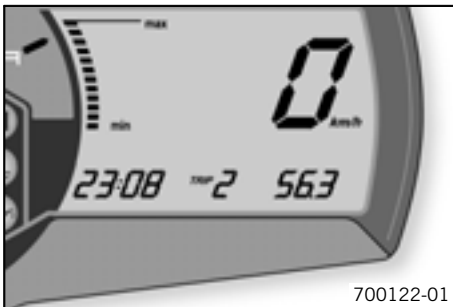

- Turn the ignition key to the position \odot .
- Press the **MODE** button several times until the **TRIP 2** display mode is active.
- Keep the **SET** button pressed.
- ✓ The **TRIP 2** display is at **0.0**.

Combination instrument - TRIP F display

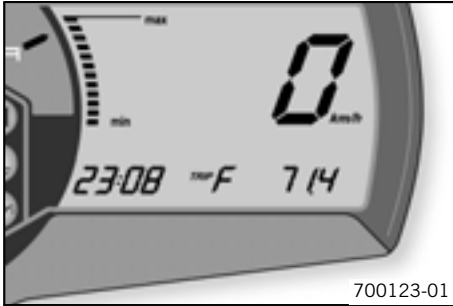

When the fuel level reaches the reserve mark, the display automatically changes to **TRIP F** and begins to count from **0.0**, regardless of which display mode was previously active.



Info

Parallel to the **TRIP F** display, the fuel warning light begins to light up.

Combination instrument - coolant temperature indicator

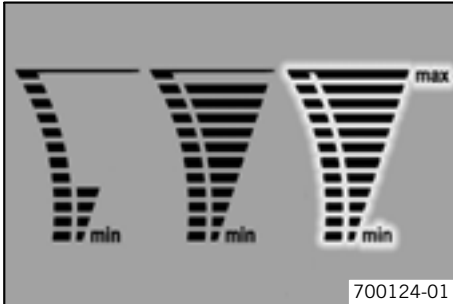

The temperature indicator in the display consists of 12 bars. The more bars that light up, the hotter the coolant. When the top bar lights up, all bars begin to flash simultaneously and the temperature warning lamp begins to light up.

Possible states

- Engine cold – up to four bars.
- Engine at normal operating temperature – from five to eleven bars.
- Engine hot – all twelve bars flash.

Opening filler cap

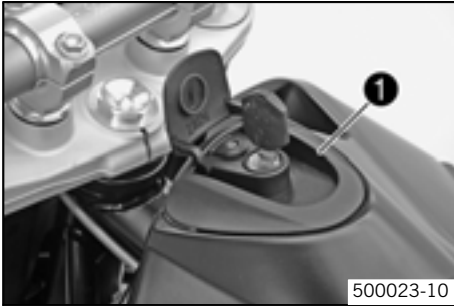

- Lift the cover of the filler cap ❶ and insert the ignition key.
- Turn the ignition key 90° counterclockwise and remove the filler cap.



Info

The filler cap has a tank air vent system.

Closing filler cap

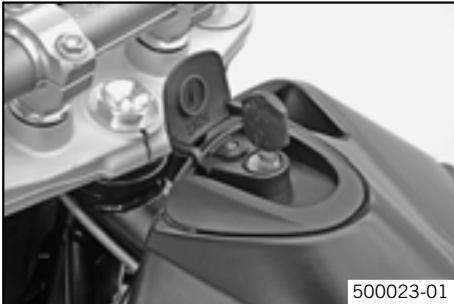

- Put the filler cap back on and turn the ignition key 90° clockwise.
- Remove the ignition key and fold down the cover.

Fuel taps

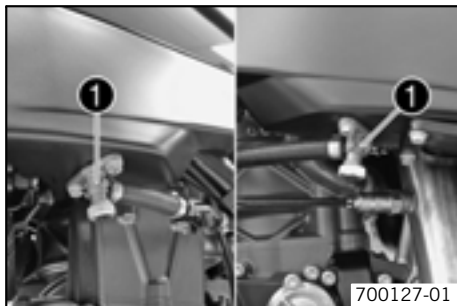

The fuel taps ❶ are located on the left/right under the fuel tank.

Possible states

- Fuel supply closed – The knurled screws are turned clockwise as far as possible. The level cannot be compensated and no fuel can flow out of the fuel tank.
- Fuel tap open – The knurled screws are turned counterclockwise as far as possible. The level can be compensated and the fuel can flow out of the fuel tank.

Handrails



The handrails ❶ are used for moving the motorcycle around.

When you have a passenger, the passenger can hold on the handrails during the journey.

Seat lock

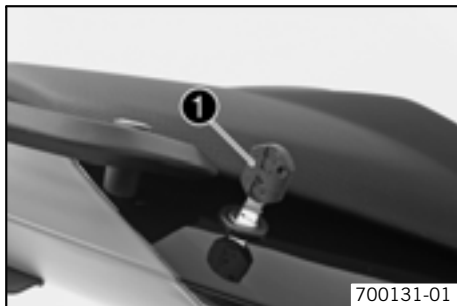

700131-01

The seat lock ❶ is located to the right of the seat.
You can lock it with the ignition key.

OWNER'S MANUAL

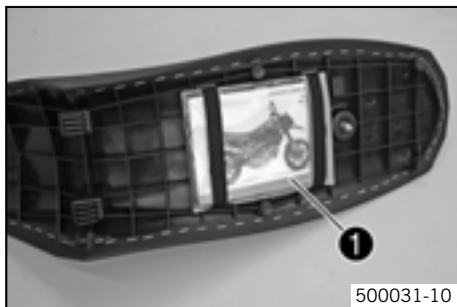

500031-10

You can find the owner's manual ❶ in its protective case on the underside of the seat.

Tool set

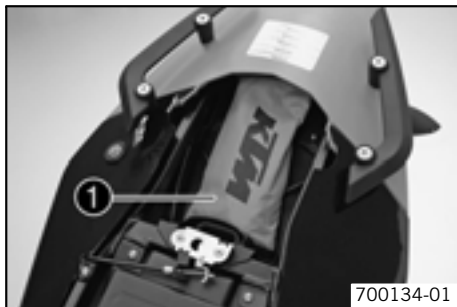

The tool set ❶ is located in the storage compartment under the seat.

Passenger footrests

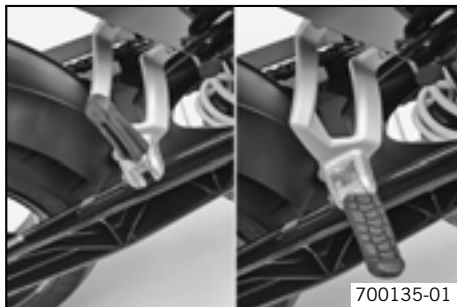

The passenger footrests can be folded in and out.

Possible states

- Passenger footrests folded up – For operation without a passenger.
- Passenger footrests folded down – For operation with a passenger.

Shift lever

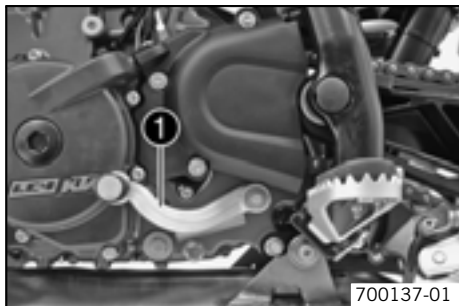

The shift lever ❶ is mounted on the left side of the engine.

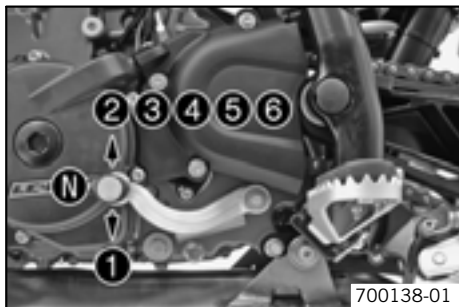

The gear positions can be seen in the photograph.
The neutral or idle position is between the first and second gears.

Foot brake pedal

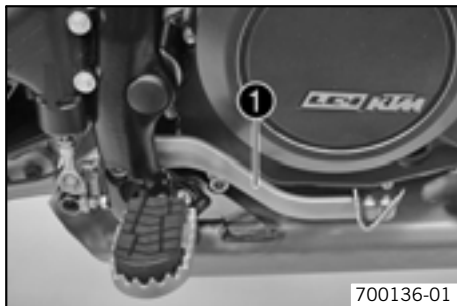

The footbrake pedal ❶ is located in front of the right footrest.
The footbrake pedal operates the rear brake.

Side stand

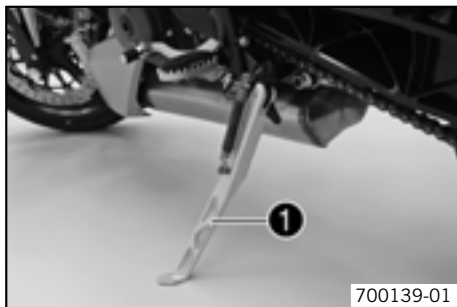

The side stand ❶ is coupled with the safety electric starter system - see the riding instructions.

Possible states

- Side stand folded out – The vehicle can be supported on the side stand. The safety electric starter system is active.
- Side stand folded in – This position is mandatory for all journeys. The safety electric starter system is inactive.

Advice on first use



Danger

Danger of accidents Danger from inadequate traffic experience.

- Do not use the vehicle if you are inexperienced or if you have consumed alcohol or drugs.



Warning

Risk of injury Risk of injury by missing/inadequate protective clothing.

- Wear protective clothing (helmet, boots, gloves, pants and jacket with protectors) every time you ride the motorcycle. Always wear protective clothing, which must be in perfect condition and meet legal requirements.



Warning

Danger of crashing Impairment of riding behavior due to different tire tread patterns on front and rear wheels.

- The front and rear wheels must be fitted with tires with similar tread patterns to prevent loss of control over the vehicle.



Warning

Danger of accidents Uncontrollable handling behavior caused by non-approved tires/wheels.

- Use only tires/wheels approved by KTM with the corresponding speed index.



Warning

Danger of accidents Reduced road grip with new tires.

- New tires have a smooth roll surface and therefore cannot provide full road grip. The entire roll surface must be roughened in the first 200 kilometers (124.3 miles) by moderate driving at alternating angles. The full grip is not reached until the vehicle has been run in.



Warning

Danger of accidents Brake system failure.

- If the foot brake pedal is not released, the brake linings drag permanently. The rear brake can fail due to overheating. Take your foot off the foot brake pedal if you do not want to brake.



Info

When using your vehicle, remember that others may feel disturbed by excessive noise.

- Make sure that the pre-delivery inspection work has been carried out by an authorized KTM workshop. You receive a delivery certificate and the service record at vehicle handover.
- Before your first trip, read the entire operating instructions carefully.
- Get to know the operating elements.
- adjust the basic position of clutch lever. (☛ P. 123)
- adjust the basic position of handbrake lever. (☛ P. 71)
- Adjust the basic position of the footbrake lever.
- Get used to handling the vehicle on a car park before making a longer trip. Try also to ride as slowly as possible and in a standing position to get a better feeling for the vehicle.
- Hold the handlebar firmly with both hands and keep your feet on the footrests when riding.
- Do not make any changes to the vehicle, and use only KTM approved parts.



Info

Parts from other manufacturers can reduce the operational safety of the vehicle.

- Run the engine in.

Running in the engine

- During the running-in phase, do not exceed the specified engine speed and engine performance.

Specification

Maximum engine speed	
During the first: 1,000 km (621.4 mi)	6,000 rpm
After the first: 1,000 km (621.4 mi)	7,800 rpm

- Avoid fully opening the throttle!

Loading the vehicle



Warning

Danger of accidents Unstable riding behavior.

- Do not exceed the maximum permitted weight and axle loads. The overall weight consists of: motorcycle operational and with a full tank, driver and passenger with protective clothing and helmet, baggage.



Warning

Danger of accidents Unstable handling characteristics due to incorrect mounting of suitcase and/or tank rucksack.

- Mount and secure suitcase and tank rucksack according to the manufacturer's instructions.



Warning

Danger of accidents Unstable handling characteristics at high speed.

- Adapt your speed according to your payload. Ride more slowly if your motorcycle is loaded with cases or other baggage.
Maximum speed with baggage 130 km/h (80.8 mph)



Warning

Danger of accidents Risk of breakage of suitcase system.

- If you have fitted suitcases on your motorcycle, read the manufacturer's specifications concerning the maximum payload.



Warning

Danger of accidents Poor visibility for other road users due to slipped baggage.

- If the tail light is covered, you are less visible to following traffic, especially in the dark. Check the way your baggage is fixed regularly.



Warning

Danger of accidents Changed handling characteristics and longer stopping distance with excessive payload.

- Adapt your speed according to your payload.

**Warning**

Danger of accidents Unstable handling characteristics due to slipped baggage.

- Check the way your baggage is fixed regularly.

**Warning**

Danger of burns A hot exhaust system can burn baggage.

- Fasten your baggage in such a way that it cannot be burned or singed by the hot exhaust system.

-
- If you carry any baggage, make sure it is fixed firmly as close as possible to the center of the vehicle and ensure even weight distribution between the front and rear wheels.
 - Do not exceed the overall maximum permitted weight and the axle loads.

Specification

Maximum permissible overall weight	350 kg (772 lb.)
Maximum permissible front axle load	150 kg (331 lb.)
Maximum permissible rear axle load	200 kg (441 lb.)

Checks before putting into operation



Info

Make sure that the motorcycle is in a perfect technical condition before use.
In the interests of riding safety, make a habit of making a general check before you ride.

- Check the engine oil level. (☛ P. 126)
- Check the engine for loss of oil.
- Check the fuel level.
- Bleed fork legs. (☛ P. 63)

Specification

all	1,000 km (621.4 mi)
-----	---------------------

- Check the chain tension. (☛ P. 65)
- Clean the chain. (☛ P. 64)
- Check the tire condition. (☛ P. 85)
- Checking the tire air pressure. (☛ P. 86)
- Check the brake fluid level of the front brake. (☛ P. 71)
- Check the rear brake fluid level. (☛ P. 75)
- Check the front brake linings. (☛ P. 74)
- Check the rear brake linings. (☛ P. 78)
- Check brake system function.
- Check the coolant level. (☛ P. 119)
- Check that all operating elements are correctly adjusted and free to move.
- Check the functioning of the electrical equipment.
- Check that baggage is correctly secured.
- Sit on the motorcycle and check the rear mirror setting.

Starting



Danger

Danger of poisoning Exhaust gases are poisonous and can result in unconsciousness and/or death.

- When running the engine, always make sure there is sufficient ventilation, and do not start or run the engine in a closed space.



Caution

Danger of accidents If the vehicle is operated with a discharged battery or without a battery, electronic components and safety equipment may be damaged.

- Never operate the vehicle with a discharged battery or without a battery.

Note

Engine failure High engine speeds in cold engines have a negative effect on the service life of the engine.

- Always warm up the engine at low engine speeds.

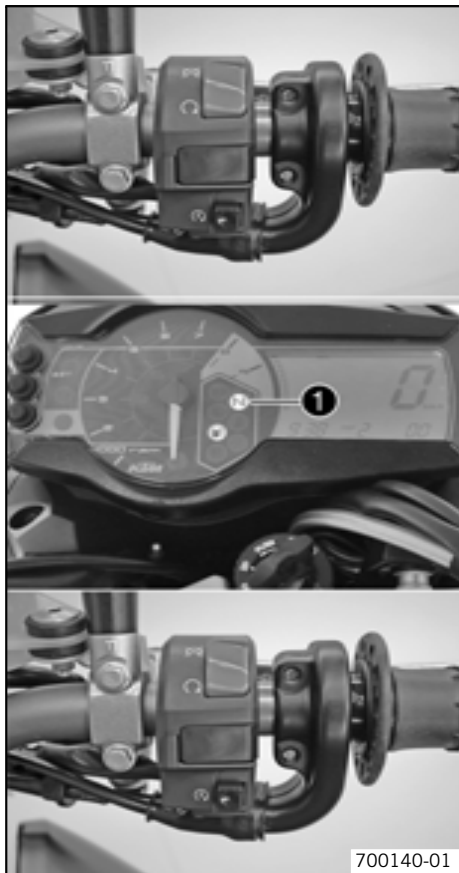

700140-01

- Turn the emergency OFF switch to the position ○.
- Turn the ignition key to the position ○.
- ✓ After switching on the ignition, you can hear the fuel pump working for about 2 seconds. At the same time, the combination instrument runs a function test.
- Shift gear to neutral.
- ✓ The green idling speed indicator lamp **N** ❶ lights up.
- Press the electric starter button ❸.

i Info

Do not press the electric starter button until the combination instrument function test is finished.

Do not open the throttle when starting. If you open the throttle when starting, the engine management injects no fuel and the engine cannot start.

Press the starter for a maximum of 5 seconds. Wait for at least 5 seconds until trying again.

This motorcycle is equipped with a safety electric starter system. The engine can be started only if the gearbox is in neutral or the clutch lever is pulled. If you shift into gear when the side stand is folded out and then release the clutch lever, the engine stalls.

- Take the weight off the side stand and swing it back up with your foot as far as it will go.

Starting up

- Pull the clutch lever, engage 1st gear, release the clutch lever slowly and simultaneously open the throttle carefully.

Shifting, riding



Warning

Danger of accidents An abrupt load alterations can cause the vehicle to get out of control.

- Avoid abrupt load alterations and sudden braking actions, and adapt your speed to the road conditions.



Warning

Danger of accidents If you change down at high engine speed, the rear wheel can lock up.

- Do not change into a low gear at high engine speed. The engine races and the rear wheel can block.



Warning

Danger of accidents Malfunctions caused by incorrect ignition key position.

- Do not change the ignition key position during a journey.



Warning

Danger of accidents Distraction from traffic activity by adjustments to the vehicle.

- Make all adjustments when the vehicle is at a standstill.



Warning

Risk of injury The passenger must be capable of sitting correctly on the passenger seat.

- The passenger must hold on to the rider or the handrails and place his feet on the passenger footrests. Note the regulations governing the minimum age of passengers in your country.



Warning

Danger of accidents Danger of accidents caused by dangerous driving.

- Observe the traffic regulations and ride defensively and with foresight in order to recognize danger as early as possible.



Warning

Danger of accidents Reduced road grip with cold tires.

- On every journey, take the first miles carefully at moderate speed until the tires reach operating temperature and optimal road grip is ensured.



Warning

Danger of accidents Reduced road grip with new tires.

- New tires have a smooth roll surface and therefore cannot provide full road grip. The entire roll surface must be roughened in the first 200 kilometers (124.3 miles) by moderate driving at alternating angles. The full grip is not reached until the vehicle has been run in.



Warning

Danger of accidents Unstable riding behavior.

- Do not exceed the maximum permitted weight and axle loads. The overall weight consists of: motorcycle operational and with a full tank, driver and passenger with protective clothing and helmet, baggage.



Warning

Danger of accidents Unstable handling characteristics due to slipped baggage.

- Check the way your baggage is fixed regularly.



Warning

Danger of accidents After a fall, check the vehicle.

- After a fall, check the vehicle as usual before putting it into operation.

Note

Engine failure Unfiltered intake air has a negative effect on the service life of the engine.

- Never ride the vehicle without an air filter since dust and dirt can get into the engine and result in increased wear.

Note

Engine failure Overheating of engine.

- If the coolant temperature warning lamp lights up, stop and switch off the engine. Allow the engine to cool down and check the coolant level in the radiator, and top up if necessary. If you continue with the coolant temperature warning lamp alight, you may have engine failure.



Info

If you hear unusual noises while riding, stop immediately, switch off the engine and contact an authorized KTM workshop.

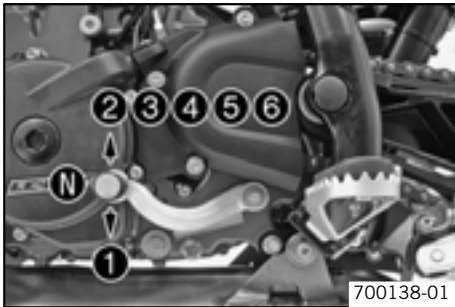

- When conditions allow (incline, road situation, etc.), you can shift into a higher gear.
- Release the throttle while simultaneously pulling the clutch lever, shift into the next gear, release the clutch and open the throttle.



Info

For the positions of the 6 forward gears, see the illustration. The neutral or idle position is between the first and second gears. First gear is used for starting off or for steep inclines.

The operating temperature is reached when 5 bars of the temperature indicator light up.

- When you reach maximum speed after fully opening the throttle, turn back the throttle to about 3/4 of its range; the speed hardly drops, but the fuel consumption falls considerably.
- Open the throttle only as far as the road and weather conditions permit. Particularly in bends, do not shift and open the throttle only very cautiously.
- To shift down, brake if necessary and close the throttle at the same time.
- Pull the clutch lever and shift into a lower gear, release the clutch lever slowly and open the throttle or shift again.

- For example, if the engine stalls at a junction, just pull the clutch and press the electric starter button. You do not need to shift into neutral.
- Switch off the engine if you expect to be standing for a long time.
- If the **FI** warning lamp (**MIL**) starts to light up during the journey, stop immediately. If you shift to neutral, the **FI** warning lamp (**MIL**) begins to flash.



Info

From the flash rhythm, you can deduce a two-digit number, the so-called flash code. The flash code tells you which component is affected by a fault.

Braking



Warning

Danger of accidents If you brake too hard, the wheels can lock.

- Adapt your braking to the traffic situation and the road conditions.



Warning

Danger of accidents Reduced braking due to wet or dirty brakes.

- Clean or dry dirty or wet brakes by riding and braking gently.



Warning

Danger of accidents Reduced braking caused by spongy pressure point of front or rear brake.

- Have the brake system checked in an authorized KTM workshop, and do not ride any further.



Warning

Danger of accidents Brake system failure.

- If the foot brake pedal is not released, the brake linings drag permanently. The rear brake can fail due to overheating. Take your foot off the foot brake pedal if you do not want to brake.



Warning

Danger of accidents Longer stopping distance due to higher overall weight.

- Take the longer stopping distance into account when carrying a passenger and baggage.



Warning

Danger of accidents Delayed brake action on salted roads.

- Salt can be deposited on the brake discs. To achieve the normal braking effect, the brake discs must first be cleaned by braking.

-
- To brake, release the throttle and operate the front and rear brakes simultaneously.
 - On sandy, wet or slippery surfaces, use the rear brake.
 - Braking should always be completed before you go into a bend. Change down to a lower gear appropriate to your road speed.
 - On long downhill stretches, use the braking effect of the engine. Change down one or two gears, but do not overstress the engine. In this way, you have to brake far less and the brakes do not overheat.

Stopping, parking



Warning

Risk of misappropriation Usage by unauthorized persons.

- Never leave the vehicle while the engine is running. Secure the vehicle against use by unauthorized persons. If you leave the vehicle, lock the steering and remove the ignition key.



Warning

Danger of burns Some vehicle components get very hot when the machine is driven.

- Do not touch hot components such as exhaust system, radiator, engine, shock absorber and brakes. Allow these components to cool down before starting work on them.

Note

Danger of damage Danger of damage by the vehicle running away or falling over.

- Always place the vehicle on a firm and even surface.

Note

Fire hazard Some components (engine, radiator and exhaust system) get very hot when the engine is running.

- Do not place the vehicle where there are flammable or explosive substances.

Note

Material damage Damage and destruction of components by excessive load.

- The side stand is designed for the weight of the motorcycle only. Do not sit on the motorcycle when it is supported by the side stand only. The side stand and/or the frame could be damaged and the motorcycle could fall over.

-
- Brake the motorcycle.
 - Shift gear to neutral.
 - Turn the ignition key to the position ☒.



Info

If the engine is switched off with the emergency OFF switch and the ignition remains switched on at the ignition lock, power continues to flow to most power consumers and the battery will discharge. You should therefore always switch off the engine with the ignition key - the emergency OFF switch is intended for emergencies only.

-
- Park the motorcycle on a hard surface.
 - Swing the side stand forward with your foot as far as it will go and lean the vehicle on it.
 - Turn the steering to the left, press the ignition key down to the position ☒ and turn it to the position ☒. To make locking the steering easier, move the handlebar a little to the left and right. Remove the ignition key.

Refueling



Danger

Fire hazard Fuel can easily catch fire.

- Never fill up the vehicle near open flames or burning cigarettes, and always switch off the engine first. Be careful that no fuel is spilled, especially on hot vehicle components. Clean up spilled fuel immediately.
- Fuel in the fuel tank expands when warm and can escape if the tank is overfilled. See specifications on filling up with fuel.



Warning

Danger of poisoning Fuel is poisonous and a health hazard.

- Avoid contact between fuel and skin, eyes and clothing. Do not inhale fuel vapors. If fuel gets into your eyes, rinse immediately with water and contact a doctor. Wash affected skin areas immediately with soap and water. If fuel is swallowed, contact a doctor immediately. Change clothing that has come into contact with fuel.



Warning

Environmental hazard Improper handling of fuel is a danger to the environment.

- Do not allow fuel to get into the ground water, the ground, or the sewage system.
-



Info

This motorcycle is equipped with a regulated catalyst. Leaded fuel will destroy the catalyst. You should therefore use unleaded fuel only.

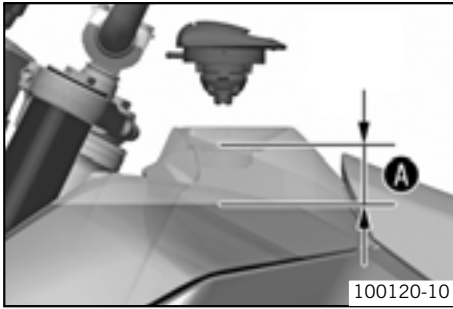

- Switch off engine.
- Open the filler cap. (☛ P. 32)
- Fill the fuel tank with fuel up to measurement **A**.

Specification





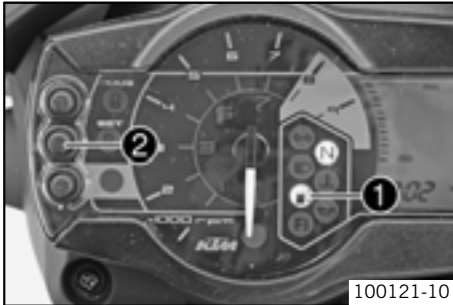





Measurement of A	50 mm (1.97 in)	
Fuel tank content	13.5 l (3.57 US gal)	Super unleaded (ROZ 95 / RON 95 / PON 91) (☛ P. 162)

- Close the filler cap. (☛ P. 32)
- Press the **SET** **2** function button for 2 seconds.
- ✓ The fuel level warning lamp **1** switches off. **TRIP F** is set to 0 and appears in the previous display mode.



i Info
 If you do not press the **SET** **2** function button, the reset takes place automatically after about 3 minutes.

Important maintenance work to be carried out by an authorized KTM workshop.

		K10N	K50A	K100A	J1A	J2A
Engine	Change engine oil and oil filter, clean oil screens.  (☞ P. 127)	•	•	•	•	•
	Check and adjust valve clearance. 			•		•
	Check engine mounting screws for tightness.	•	•	•	•	•
	Replace spark plug.			•		
	Check engine bolts accessible from outside for tightness.	•	•	•	•	•
Fuel injection	Check connection boots for cracks and leakage. 	•		•		•
	Read out the error memory with a KTM diagnostic tool. 	•	•	•	•	•
	Check fuel hoses, SLS hoses and vent hoses for damage, correct fitting and leaks. 	•	•	•	•	•
	Clean, check and grease the O-ring of the fuel hose connection. 		•	•	•	•
	Check the cable harness of the throttle valve body for damage and correct positioning. 	•		•		•
Attachments	Check the cooling system for leakage.	•	•	•	•	•
	Check the antifreeze and coolant level. (☞ P. 116)	•	•	•	•	•
	Check the functioning of the radiator fan. 	•	•	•	•	•
	Check the exhaust system for leaks and correct fitting and check that the exhaust holders are tight. 	•	•	•	•	•
	Check Bowden cables for damage, smooth operation, routing without sharp bends and setting.	•	•	•	•	•
	Check/correct the fluid level of the hydraulic clutch. (☞ P. 124)		•	•	•	•
	Check air filter and change if necessary. Clean the air filter box. 		•	•	•	•
	Check cables for damage and routing without sharp bends. 	•	•	•	•	•
	Check the headlamp setting.	•	•	•	•	•

		K10N	K50A	K100A	J1A	J2A
Attachments	Check the functioning of the electrical equipment.	•	•	•	•	•
	Check screws and nuts for tightness.	•	•	•	•	•
Brakes	Check the front brake linings. (☞ P. 74)	•	•	•	•	•
	Check the rear brake linings. (☞ P. 78)	•	•	•	•	•
	Check the brake discs. (☞ P. 70)	•	•	•	•	•
	Check the brake fluid level of the front brake. (☞ P. 71)	•	•	•	•	•
	Check the rear brake fluid level. (☞ P. 75)	•	•	•	•	•
	Change brake fluid. 🛠️					•
	Check brake lines for damage and leakage.	•	•	•	•	•
	Check the free play of the foot brake lever. (☞ P. 75)	•	•	•	•	•
	Check braking.	•	•	•	•	•
	Check screws and guide bolts of brake system for tightness. 🛠️	•	•	•	•	•
	Chassis	Check shock absorber and fork for leakage and functioning. 🛠️	•	•	•	•
Clean dust boots of fork legs. 🛠️			•	•	•	•
Bleed fork legs. (☞ P. 63)		•	•	•	•	•
Check swingarm bearing. 🛠️		•	•	•	•	•
Check play of steering head bearing. 🛠️		•	•	•	•	•
Check all screws to see if they are tight.		•	•	•	•	•
Grease Pro-Lever deflector. 🛠️						•
Wheels	Check rim run-out. 🛠️	•	•	•	•	•
	Check the tire condition. (☞ P. 85)	•	•	•	•	•
	Checking the tire air pressure. (☞ P. 86)	•	•	•	•	•
	Check the chain wear. (☞ P. 69)	•	•	•	•	•

		K10N	K50A	K100A	J1A	J2A
Wheels	Check rear sprocket / engine sprocket for tightness.	•	•	•	•	•
	Check rear sprocket / engine sprocket for wear. (☞ P. 68)	•	•	•	•	•
	Check the chain tension. (☞ P. 65)	•	•	•	•	•
	Clean the chain. (☞ P. 64)	•	•	•	•	•
	Check wheel bearing for play. ☞		•	•	•	•
	Checking the rear hub rubber dampers. ☞ (☞ P. 84)		•	•	•	•

K10N: after 1,000 km (621.4 mi)

K50A: every 5,000 km (3,107 mi)

K100A: every 10,000 km (6,214 mi)

J1A: annually

J2A: every 2 years

Important maintenance work to be carried out by an authorized KTM workshop. (as additional order)

	K100A	J1A	J2A
Carry out a complete fork service. ☞	•		•
Carry out a complete shock absorber service. ☞	•		•
Clean and grease steering head bearing and sealing elements. ☞			•
Treat electric contacts with contact spray.		•	•
Clean the battery terminals and treat them with contact grease.		•	•
Change coolant. ☞			•

K100A: every 10,000 km (6,214 mi)

J1A: annually

J2A: every 2 years

Jacking up front of motorcycle

Note

Danger of damage Danger of damage by the vehicle running away or falling over.

- Always place the vehicle on a firm and even surface.

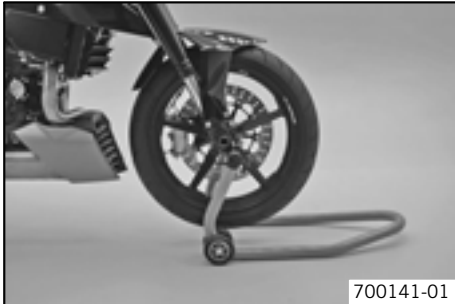

- Jack up the rear of the motorcycle. (☛ P. 57)
- Move the handlebar to the straight-ahead position. Align the work stand to the front with the adapters to the fork legs.

Work stand front (61029055300)



Info

Always jack up the rear of the motorcycle first.

- Jack up the front of the motorcycle.

Taking front from work stand

Note

Danger of damage Danger of damage by the vehicle running away or falling over.

- Always place the vehicle on a firm and even surface.

- Secure the motorcycle against falling over.
- Remove the work stand at the front.

Jacking up rear of motorcycle

Note

Danger of damage Danger of damage by the vehicle running away or falling over.

- Always place the vehicle on a firm and even surface.

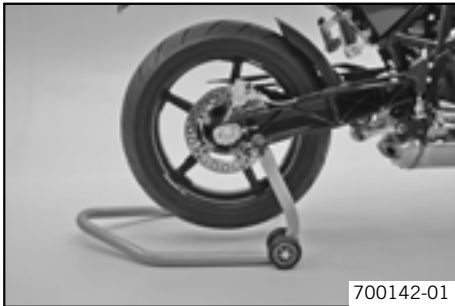

- Insert the work stand adapter in the work stand and screw it into the link forks.

Work stand adapter (61029055110)

Work stand rear (61029055100)

- Stand the motorcycle upright, align the work stand to the rear, and jack up the motorcycle.

Take the rear from the work stand.

Note

Danger of damage Danger of damage by the vehicle running away or falling over.

- Always place the vehicle on a firm and even surface.
- Secure the motorcycle against falling over.
- Remove the work stand from the rear and lean the vehicle on the side stand.

Fork/shock absorber

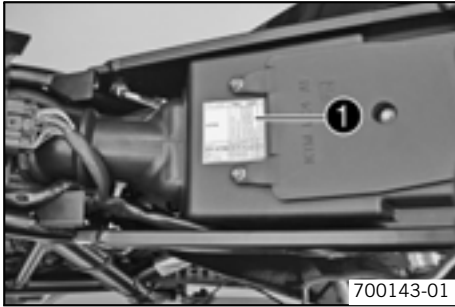

The fork and the shock absorber offer many options of adapting the chassis to your riding style and the payload.



Info

To help you adapt the vehicle, we have summarized our findings in Table 1. You can find the table on the air filter box under the seat.

These adjustments should be understood as a guideline and should always be the basis of your own personal chassis adaptation. Do not change the adjustments at random or by more than $\pm 40\%$, since otherwise the riding characteristics could deteriorate, particularly at high speeds.

Adjusting compression damping of fork



Info

The hydraulic compression damping determines the fork suspension behavior.

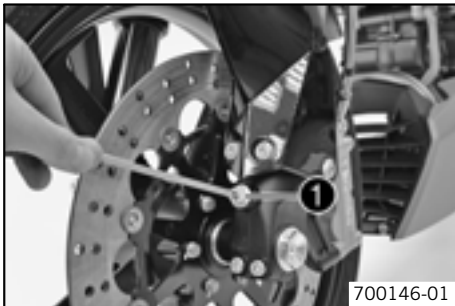

- Turn adjusting screws 1 clockwise until they stop.



Info

The adjusting screws are located at the bottom end of the fork legs. Make the same adjustment on both fork legs.

- Turn back counterclockwise the number of clicks corresponding to the fork type.

Specification

Compression damping	
Comfort	20 clicks
Standard	15 clicks
Sport	10 clicks
full payload	10 clicks



Info

Turn clockwise to increase damping, turn counterclockwise to reduce suspension damping.

Adjusting rebound damping of fork



Info

The hydraulic rebound damping determines the fork suspension behavior.

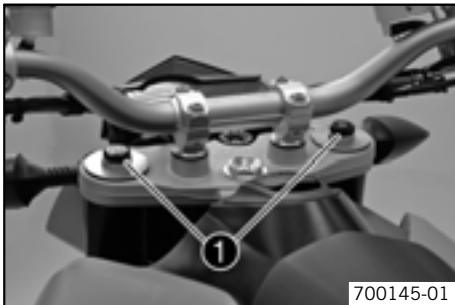

700145-01

- Turn adjusting screws ❶ clockwise until they stop.



Info

The adjusting screws are located at the top end of the fork legs. Make the same adjustment on both fork legs.

- Turn back counterclockwise the number of clicks corresponding to the fork type.

Specification

Rebound damping	
Comfort	20 clicks
Standard	15 clicks
Sport	10 clicks
full payload	10 clicks



Info

Turn clockwise to increase damping, turn counterclockwise to reduce suspension damping.

Compression damping of shock absorber

The shock absorber can regulate compression damping in low- and high-speed range separately (Dual Compression Control). The term low and high speed refers to the movement of the shock absorber during compression and not the riding speed of the motorcycle. The low- and high-speed technology works non-specifically.

Adjusting the low-speed compression damping of the shock absorber



Danger

Danger of accidents The shock absorber is under high pressure.

- The shock absorber is filled with highly compressed nitrogen, so never dismantle the shock absorber or carry out any maintenance on it yourself.



Info

The low-speed setting can be seen during the slow to normal compression of the shock absorber.

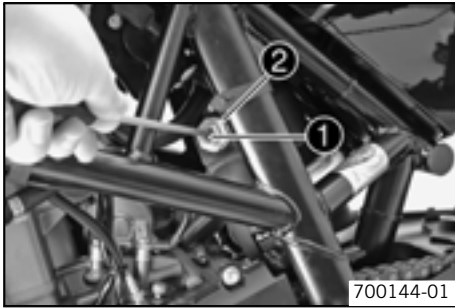

- Turn the adjusting screw ❶ clockwise with a screwdriver until it stops.



Info

Do not loosen nut ❷!

- Turn back counterclockwise the number of clicks corresponding to the shock absorber type.

Specification

Compression damping, low-speed	
Comfort	20 clicks
Standard	15 clicks
Sport	10 clicks
full payload	10 clicks



Info

Turn clockwise to increase damping, turn counterclockwise to reduce suspension damping.

Adjusting high-speed compression damping of the shock absorber



Danger

Danger of accidents The shock absorber is under high pressure.

- The shock absorber is filled with highly compressed nitrogen, so never dismantle the shock absorber or carry out any maintenance on it yourself.



Info

The high-speed setting can be seen during the fast compression of the shock absorber.

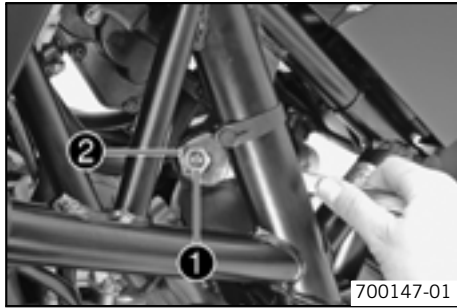

- Turn the adjusting screw ❶ clockwise with an open-ended spanner until it stops.



Info

Do not loosen nut ❷!

- Turn back counterclockwise the number of turns corresponding to the shock absorber type.

Specification

Compression damping, high-speed	
Comfort	2 turns
Standard	1.5 turns
Sport	1 turn
full payload	1 turn



Info

Turn clockwise to increase damping, turn counterclockwise to reduce suspension damping.

Adjusting rebound damping of the shock absorber



Danger

Danger of accidents The shock absorber is under high pressure.

- The shock absorber is filled with highly compressed nitrogen, so never dismantle the shock absorber or carry out any maintenance on it yourself.



- Turn the adjusting screw ❶ clockwise until it stops.
- Turn back counterclockwise the number of clicks corresponding to the shock absorber type.

Specification

Rebound damping	
Comfort	20 clicks
Standard	15 clicks
Sport	10 clicks
full payload	10 clicks



Info

Turn clockwise to increase damping, turn counterclockwise to reduce suspension damping.

Bleeding fork legs

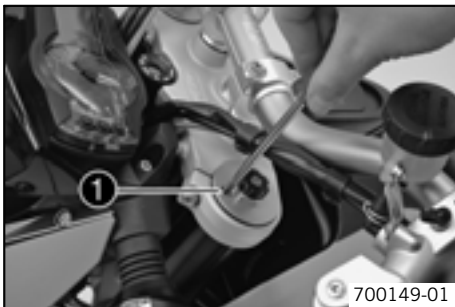

- Lean the motorcycle on the side stand.
- Remove bleeder screws ❶ briefly.
- ✓ Any excess pressure escapes from the interior of the fork.
- Mount and tighten bleeder screws.



Info

Carry out this action on both fork legs.

Checking chain dirt

- Check the chain for coarse dirt accumulation.
 - » If the chain is very dirty:
 - Clean the chain. (☛ P. 64)

Cleaning the chain



Warning

Danger of accidents Oil or grease on the tires reduces their grip.

- Remove oil and grease with a suitable cleaning material.



Warning

Danger of accidents Reduced braking due to oil or grease on the brake discs.

- Always keep the brake discs free of oil and grease, and clean them with brake cleaner when necessary.



Warning

Environmental hazard Problem materials cause environmental damage.

- Dispose of oil, grease, filters, fuel, cleaning substances, brake fluid, batteries, etc. according to regulations.



Info

The service life of the chain depends largely on its maintenance.

- Clean the chain regularly.
- Rinse off loose dirt with a soft jet of water.
- Remove old grease remains with chain cleaner.

Chain cleaner (☛ P. 165)

- After drying, apply chain spray.

Onroad chain spray (☛ P. 165)

Checking the chain tension



Warning

Danger of accidents Danger caused by incorrect chain tension.

- If the chain tension is too high, the components of the secondary power train (chain, engine sprocket, rear sprocket, bearings in transmission and rear wheel) are under additional load. Apart from premature wear, in extreme cases the chain can rupture or the countershaft of the transmission can break. On the other hand, if the chain is loose, it can fall off the engine sprocket or the rear sprocket and block the rear wheel or damage the engine. Check for correct chain tension and adjust if necessary.

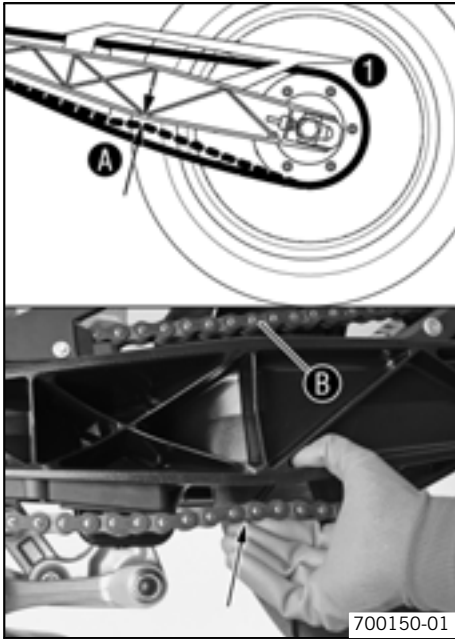

- Lean the motorcycle on the side stand.
- Shift gear to neutral.
- Push the chain upwards near the vertical rib of the swingarm and measure the chain tension **A**.



Info

The upper chain section **B** must be taut. Chain wear is not always even, so you should repeat this measurement at different chain positions.

Chain tension	5 mm (0.2 in)
---------------	---------------

- » If the chain tension does not meet specifications:
 - Adjust the chain tension. (🔧 P. 66)

Adjusting chain tension



Warning

Danger of accidents Danger caused by incorrect chain tension.

- If the chain tension is too high, the components of the secondary power train (chain, engine sprocket, rear sprocket, bearings in transmission and rear wheel) are under additional load. Apart from premature wear, in extreme cases the chain can rupture or the countershaft of the transmission can break. On the other hand, if the chain is loose, it can fall off the engine sprocket or the rear sprocket and block the rear wheel or damage the engine. Check for correct chain tension and adjust if necessary.

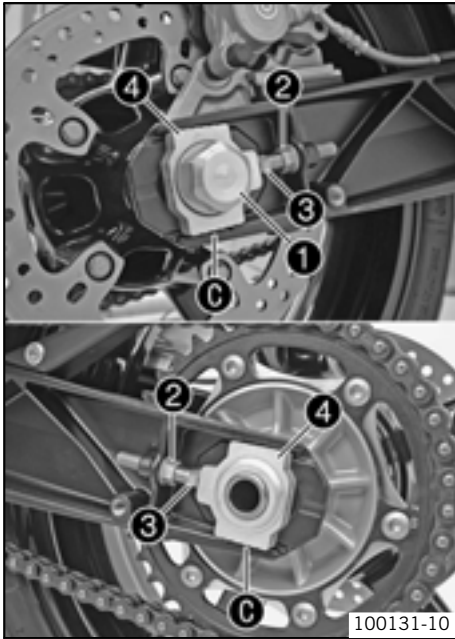

100131-10

- Lean the motorcycle on the side stand.
- Shift gear to neutral.
- Loosen nut ❶.
- Loosen nuts ❷.
- Adjust the chain tension by turning the adjusting screws ❸ left and right.

Specification

Chain tension	5 mm (0.2 in)
Turn the adjusting screws ❸ left and right so that the markings on the left and right chain adjusters ❹ are in the same position relative to the reference marks ❷. The rear wheel is then correctly aligned.	

i Info
 The upper chain section must be taut.
 Chain wear is not always even, so you should repeat this measurement at different chain positions.

- Tighten nuts ❷.
- Make sure that the chain adjusters ❹ are fitted correctly on the adjusting screws ❸.
- Tighten nut ❶.

Specification

Nut, rear wheel spindle	M25x1.5	90 Nm (66.4 lbf ft)
-------------------------	---------	---------------------

i Info
 The wide adjustment range of the chain adjusters (32 mm) enables different secondary transmissions with the same chain length.
 The chain adjusters ❹ can be turned by 180°.

Checking rear sprocket / engine sprocket for wear

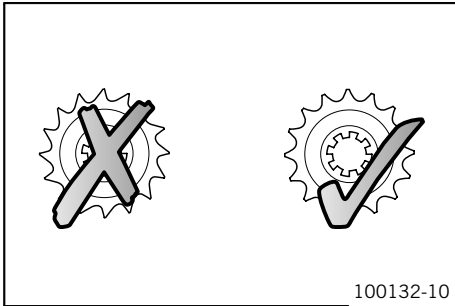

- Check rear sprocket / engine sprocket for wear.
 - » If the rear sprocket / engine sprocket are worn:
 - Replace rear sprocket / engine sprocket.



Info

The engine sprocket, rear sprocket and chain should always be replaced together.

For safety reasons, the chain has no chain joint. Always have the chain replaced in an authorized KTM workshop, where the necessary chain rivet tool is available.

- Check chain guides for tightness and wear.

Checking chain wear

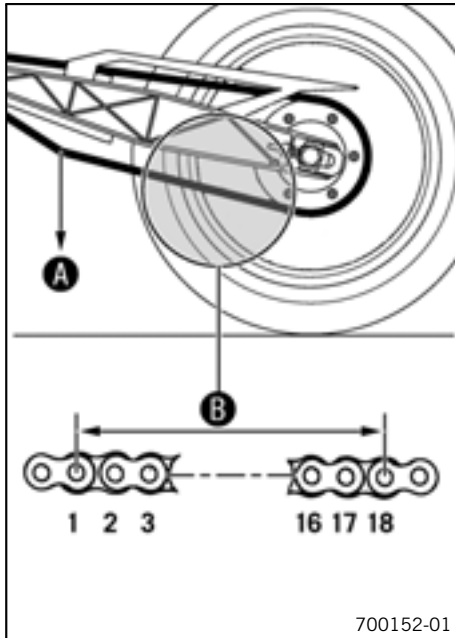

- Shift into neutral, pull the lower chain section with the specified weight **A**.

Specification

Weight of chain wear measurement	15 kg (33 lb.)
----------------------------------	----------------

- Measure the distance **B** of 18 chain links in the lower chain section.

i Info

Chain wear is not always even, so you should repeat this measurement at different chain positions.

Maximum distance B at the longest chain section	272 mm (10.71 in)
--	-------------------

- » If the distance **B** is greater than the specified measurement:
 - Have the chain changed.

i Info

When the chain is replaced, the rear sprocket and engine sprocket should also be changed.

New chains wear out faster on old, worn sprockets.

For safety reasons, the chain has no chain joint. Always have the chain changed in an authorized KTM workshop, where the necessary tool is available.

Checking brake discs



Warning

Danger of accidents Reduced braking due to worn brake discs.

- Worn brake discs should be replaced immediately in an authorized KTM workshop.

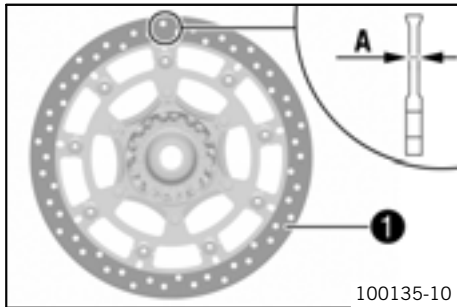

- Check the thickness of the front and rear brake discs at several places on the disc to see if it conforms to measurement **A**.



Info

Wear reduces the thickness of the brake disc around the area used by the brake linings. **1**.

Wear limit of brake discs	
front	3.6 mm (0.142 in)
Rear	4.5 mm (0.177 in)

- » If the brake disc thickness is less than the specified value:
 - Change the brake disc.

Adjusting basic position of handbrake lever

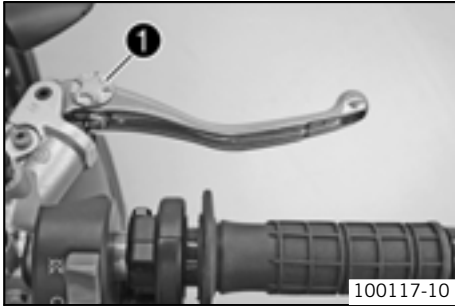

- Adjust the basic setting of the handbrake lever to your hand size by turning adjusting wheel ❶.



Info

Pull the brake lever forwards and turn the adjusting wheel.
Do not make any adjustments while riding!

Checking brake fluid level of front brake



Warning

Danger of accidents Brake system failure.

- **MIN**If the brake fluid level falls below the MIN mark, this indicates a leakage in the brake system or worn-out brake linings. Have the brake system checked in an authorized KTM workshop, and do not ride any further.



Warning

Danger of accidents Reduced braking due to old brake fluid.

- Have the front and rear brake fluid replaced according to the service plan in an authorized KTM workshop.

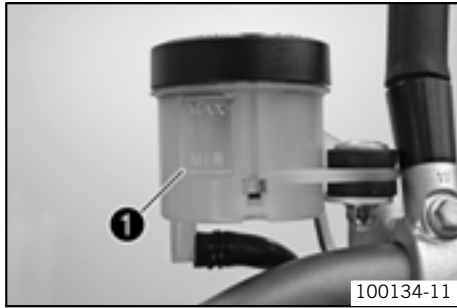

- The brake fluid level must not fall below the **MIN** marking ❶ when the brake fluid reservoir is vertical.
 - » If the brake fluid is below the **MIN** marking:
 - Top up the brake fluid of the front brake. 🛠️ (📖 P. 72)

Topping up brake fluid of front brake 🛠️



Warning

Danger of accidents Brake system failure.

- **MIN** If the brake fluid level falls below the MIN mark, this indicates a leakage in the brake system or worn-out brake linings. Have the brake system checked in an authorized KTM workshop, and do not ride any further.



Warning

Skin irritations Brake fluid can cause skin irritation on contact.

- Avoid contact with skin and eyes, and keep out of the reach of children.
- If brake fluid gets into your eyes, rinse thoroughly with water and contact a doctor immediately.



Warning

Danger of accidents Reduced braking due to old brake fluid.

- Have the front and rear brake fluid replaced according to the service plan in an authorized KTM workshop.



Warning

Environmental hazard Problem materials cause environmental damage.

- Dispose of oil, grease, filters, fuel, cleaning substances, brake fluid, batteries, etc. according to regulations.



Info

KTM recommends DOT 5.1 brake fluid from **Motorex®**. It has a higher wet boiling point than DOT 4 brake fluid and provides greater safety for high demands.

Never use DOT 5 brake fluid! It is based on silicone oil and is colored purple. Oil seals and brake lines are not designed for DOT 5 brake fluid.

Avoid contact between brake fluid and painted parts. Brake fluid attacks paint!

Use only clean brake fluid from a sealed container!

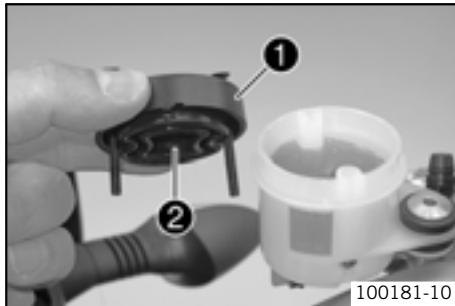

- Loosen screws.
- Remove cover ❶ with membrane ❷.
- Top up the brake fluid to **MAX** level.
- Check parts for damage and wear. Replace damaged or worn parts.
- Position the cover with the membrane. Mount and tighten screws.



Info

Clean up overflowed or spilt brake fluid immediately with water.

Brake linings

The brake linings fitted by KTM were tested over long periods and ensure optimal braking properties. The type names of brake pads are entered in the homologation documents.



Info

Brake linings available from accessory suppliers are often not tested and approved for use on KTM vehicles. The construction and friction factor of the brake linings and therefore the brake power can differ considerably from the original KTM brake linings. If brake linings are used that differ from the originals, there is no guarantee that they comply with the original license. The vehicle no longer corresponds to the condition at delivery, and the warranty is no longer valid.

Checking the front brake linings



Warning

Danger of accidents Reduced braking due to worn brake linings.

- Worn brake linings should be replaced immediately in an authorized KTM workshop.

Note

Danger of accidents Reduced braking due to damaged brake discs.

- If the brake linings are not changed in time, the steel brake lining carriers grind on the brake disc. The braking effect is greatly reduced and the brake discs are destroyed.

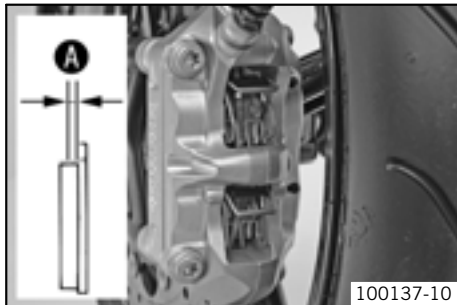

- Check the brake linings for minimum thickness **A**.
 - » Minimum thickness **A**: $\geq 1 \text{ mm}$ ($\geq 0.04 \text{ in}$)
If the minimum thickness is less than specified:
 - Worn brake linings should be replaced immediately in an authorized KTM workshop.

Checking free play of foot brake lever



Warning

Danger of accidents Brake system failure.

- If there is no free travel on the foot brake pedal, pressure builds up on the rear brake in the brake system. The rear brake can fail due to overheating. Adjust free travel on foot brake pedal according to specifications.



- Disconnect spring ❶.
- Move the foot brake lever backwards and forwards between the end stop and the foot brake cylinder piston bracket and check free play ❷.

Specification

Free play at foot brake lever	3... 5 mm (0.12... 0.2 in)
-------------------------------	----------------------------

- » If the free travel does not meet specifications:
 - Have the free travel corrected in an authorized KTM workshop.
- Reconnect spring ❶.

Checking rear brake fluid level



Warning

Danger of accidents Brake system failure.

- **MIN**If the brake fluid level falls below the MIN mark, this indicates a leakage in the brake system or worn-out brake linings. Have the brake system checked in an authorized KTM workshop, and do not ride any further.



Warning

Danger of accidents Reduced braking due to old brake fluid.

- Have the front and rear brake fluid replaced according to the service plan in an authorized KTM workshop.

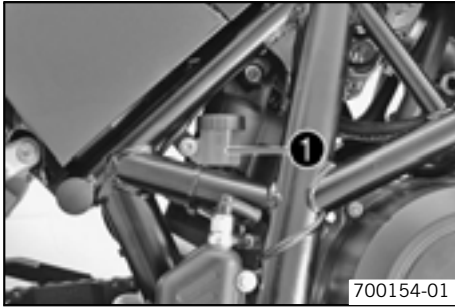

- Stand the vehicle upright.
- Check the brake fluid level in the brake fluid reservoir.
 - » If the fluid level reaches the **MIN** marking ❶:
 - Top up the brake fluid of the rear brake. 🛠️ (📄 P. 76)

Topping up brake fluid of front brake 🛠️



Warning

Danger of accidents Brake system failure.

- **MIN** If the brake fluid level falls below the MIN mark, this indicates a leakage in the brake system or worn-out brake linings. Have the brake system checked in an authorized KTM workshop, and do not ride any further.



Warning

Skin irritations Brake fluid can cause skin irritation on contact.

- Avoid contact with skin and eyes, and keep out of the reach of children.
- If brake fluid gets into your eyes, rinse thoroughly with water and contact a doctor immediately.



Warning

Danger of accidents Reduced braking due to old brake fluid.

- Have the front and rear brake fluid replaced according to the service plan in an authorized KTM workshop.



Warning

Environmental hazard Problem materials cause environmental damage.

- Dispose of oil, grease, filters, fuel, cleaning substances, brake fluid, batteries, etc. according to regulations.



Info

KTM recommends DOT 5.1 brake fluid from **Motorex®**. This has a higher wet boiling point than DOT 4 brake fluid and provides greater safety for high demands.

Never use DOT 5 brake fluid! This is based on silicone oil and is colored purple. Oil seals and brake lines are not designed for DOT 5 brake fluid.

Avoid contact between brake fluid and painted parts. Brake fluid attacks paint!

Use only clean brake fluid from a sealed container!

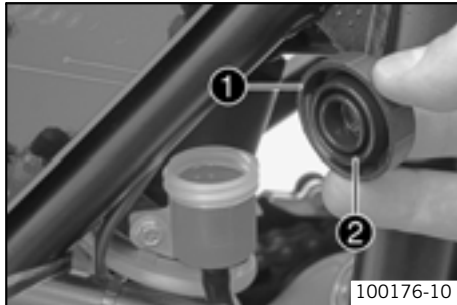

- Stand the vehicle upright.
- Remove screw cover ❶ with membrane ❷.
- Top up the brake fluid to **MAX** level.

Brake fluid DOT 5.1 (☞ P. 162)

- Check parts for damage and wear. Replace damaged or worn parts.
- Refit screw with membrane.



Info

Clean up overflowed or spilt brake fluid immediately with water.

Checking rear brake linings



Warning

Danger of accidents Reduced braking due to worn brake linings.

- Worn brake linings should be replaced immediately in an authorized KTM workshop.

Note

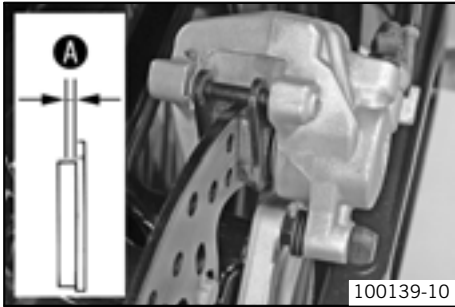

Danger of accidents Reduced braking due to damaged brake discs.

- If the brake linings are not changed in time, the steel brake lining carriers grind on the brake disc. The braking effect is greatly reduced and the brake discs are destroyed.



- Check the brake linings for minimum thickness **A**.
 - » Minimum thickness **A**: $\geq 1 \text{ mm}$ ($\geq 0.04 \text{ in}$)
If the minimum thickness is less than specified:
 - Worn brake linings should be replaced immediately in an authorized KTM workshop.

Removing front wheel

- Jack up the rear of the motorcycle. ( P. 57)
- Jack up the front of the motorcycle. ( P. 56)

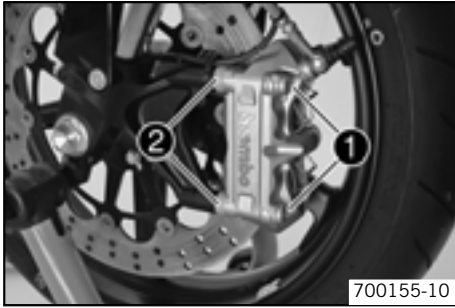

- Remove screw ❶ and spacing sleeve ❷.
- Press back the brake linings with a light lateral tilting of the brake caliper on the brake disc. Pull the brake caliper carefully back from the brake disc and hang it to one side.

i Info

Do not pull the handbrake lever when the brake caliper is removed.

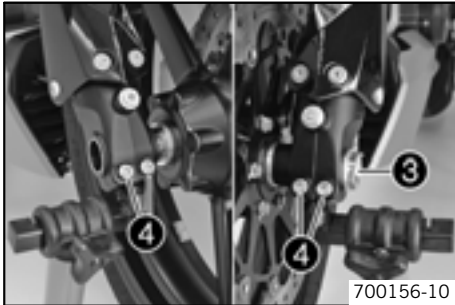

- Loosed screw ❸ and screw ❹.
- Screw out screw ❸ about 6 turns, press your hand on the screw to push the wheel spindle out of the fork stub. Remove screw ❸.

⚠ Warning

Danger of accidents Reduced braking due to damaged brake discs.

- Always lay the wheel down in such a way that the brake disc is not damaged.
- Holding the front wheel, withdraw the wheel spindle. Take the front wheel out of the fork.

Fitting front wheel

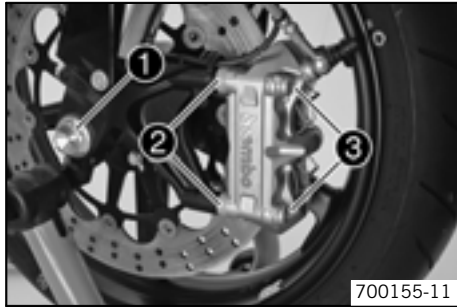

Warning

Danger of accidents Reduced braking due to oil or grease on the brake discs.

- Always keep the brake discs free of oil and grease, and clean them with brake cleaner when necessary.

- Check parts for damage and wear. Replace damaged or worn parts.
- Clean and grease the thread of the wheel spindle and screw ❶.

Long-life grease ( P. 165)

- Lift the front wheel into the fork, position it, and insert the wheel spindle. Mount and tighten screw ❶.

Specification

Screw, front wheel spindle	M24x1.5	40 Nm (29.5 lbf ft)
----------------------------	---------	---------------------

- Position the brake caliper and check that the brake linings are seated correctly.
- Position the spacing sleeves ❷. Mount and tighten screws ❸.

Specification

Screw, front brake caliper	M10x1.25	45 Nm (33.2 lbf ft)	Loctite® 243™
----------------------------	----------	------------------------	----------------------

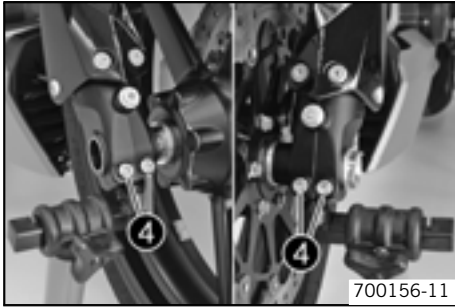

- Operate the hand brake lever several times until the brake pads are lying correctly on the brake disc.
- Take the front from the work stand. (🔧 P. 56)
- Pull the front wheel brake and push down hard on the fork several times to align the fork legs.
- Fully tighten screws ④.

Specification

Screw, fork stub	M8	15 Nm (11.1 lbf ft)
------------------	----	---------------------

- Taking rear from work stand. (🔧 P. 57)

Removing rear wheel 🛠️

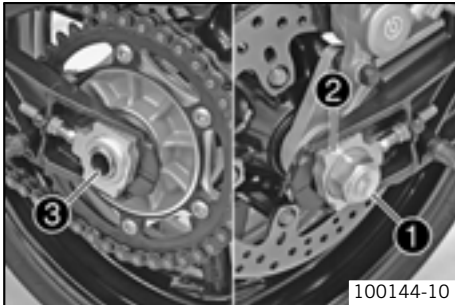

- Jack up the rear of the motorcycle. (🔧 P. 57)
- Remove nut ①. Remove chain adjuster ②. Holding the rear wheel, withdraw the wheel spindle ③.
- Push the rear wheel forwards as far as possible and take the chain off the rear sprocket.

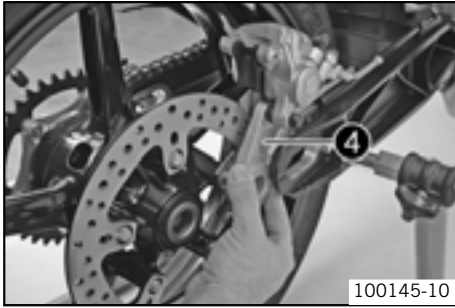

- Pull the rear wheel and brake caliper support ④ together to the rear until you can swing the brake caliper support to the side.



Warning

Danger of accidents Reduced braking due to damaged brake discs.

- Always lay the wheel down in such a way that the brake disc is not damaged.
-
- Take the rear wheel out of the swing arm.



Info

Do not operate the foot brake when the rear wheel is removed.

Fitting rear wheel



Warning

Danger of accidents Reduced braking due to oil or grease on the brake discs.



- Always keep the brake discs free of oil and grease, and clean them with brake cleaner when necessary.



Warning

Danger of accidents No braking effect when operating the rear brake.

- After installing the rear wheel, always operate the footbrake until the pressure point is reached.

-
- Checking the rear hub rubber dampers.  ( P. 84)

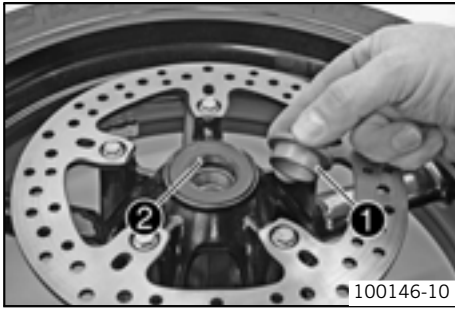

- Check parts for damage and wear. Replace damaged or worn parts.
- Remove the bushing ❶. Clean and grease the roll surfaces of the bushing and the shaft seal ring ❷.

Long-life grease (☞ P. 165)

- Clean and grease the thread of the wheel spindle and nut ❹.

Long-life grease (☞ P. 165)

- Clean the fixing locations on the brake caliper support and swingarm.
- Mount the rubber damper and rear sprocket carrier in the rear wheel.
- Stand the rear wheel in the swingarm and mount the brake caliper on the brake disc.
- Push the brake caliper support and the swingarm ❶ into the fixing location. Lay the chain on the rear sprocket and fit the wheel spindle.



Info

Fit the chain left and right adjusters ❸ in similar positions.

- Push the rear wheel forwards so that the chain adjusters are located on the adjusting screws, and tighten nut ❹.

Specification

In order for the rear wheel to be correctly aligned, the markings on the left and right chain adjusters must be in the same position relative to the reference marks ❷.

Nut, rear wheel spindle	M25x1.5	90 Nm (66.4 lbf ft)
-------------------------	---------	---------------------

- Operate the foot brake lever repeatedly until the brake linings lie on the brake disc and there is a tight spot.
- Taking rear from work stand. (☞ P. 57)

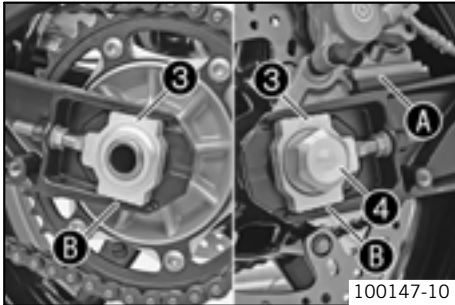

Checking the rear hub rubber dampers

Info

The engine power is transmitted from the rear sprocket to the rear wheel via 6 rubber dampers. They eventually wear out during operation. If the rubber dampers are not changed in time, the rear sprocket carrier and the rear hub will be damaged.

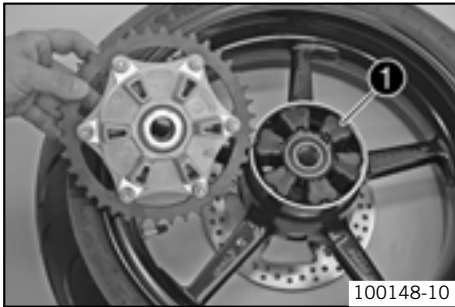

- Remove the rear wheel. (P. 81)
- Check the rubber dampers of the rear hub for damage and wear.
 - » If the rubber dampers of the rear hub are damaged or worn:
 - Change all rubber dampers in the rear hub.



- Lay the rear wheel on a workbench with the rear sprocket facing upwards and insert the wheel spindle in the hub.
- To check the play **A**, hold the rear wheel tight and try to rotate the rear sprocket.

Info

Measure the play on the outside of the rear sprocket.

Play in rubber dampers, rear wheel	≤ 5 mm (≤ 0.2 in)
------------------------------------	-------------------

- » If the play **A** is more than the specified value:
 - Change all rubber dampers in the rear hub.
- Fit the rear wheel. (P. 82)

Tire condition checking



Warning

Danger of accidents Uncontrollable handling behavior caused by a flat tire.

- For your own safety, have damaged tires changed immediately.



Warning

Danger of crashing Impairment of riding behavior due to different tire tread patterns on front and rear wheels.

- The front and rear wheels must be fitted with tires with similar tread patterns to prevent loss of control over the vehicle.



Warning

Danger of accidents Uncontrollable handling behavior caused by non-approved tires/wheels.

- Use only tires/wheels approved by KTM with the corresponding speed index.



Warning

Danger of accidents Reduced road grip with new tires.

- New tires have a smooth roll surface and therefore cannot provide full road grip. The entire roll surface must be roughened in the first 200 kilometers (124.3 miles) by moderate driving at alternating angles. The full grip is not reached until the vehicle has been run in.



Info

The type, condition and air pressure of the tires all have an important impact on the riding behavior of the motorcycle. Worn tires have a negative effect on riding behavior, especially on wet surfaces.



- Examine the tires for cuts, foreign bodies and other damage.
- Check the depth of the tread.

»



Info

Note local national regulations concerning the minimum tread depth.

- Minimum tread depth: ≥ 2 mm (≥ 0.08 in)
 If the minimum tread depth is insufficient:
- Change the tires.

Checking tire air pressure



Info

Low tire air pressure leads to abnormal wear and overheating of the tire.
 Correct tire air pressure ensures optimal riding comfort and maximum tire service life.

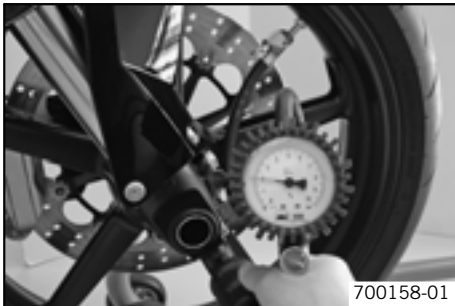

- Remove dust cap.
- Check tire air pressure when tires are cold.

Tire air pressure, road, solo	
front	2.0 bar (29 psi)
Rear	2.0 bar (29 psi)
Tire air pressure with passenger / fully loaded	
front	2.0 bar (29 psi)
Rear	2.2 bar (32 psi)

- » If the tire pressure does not meet specifications:
 - Correct tire pressure.
- Mount dust cap.

Removing the seat

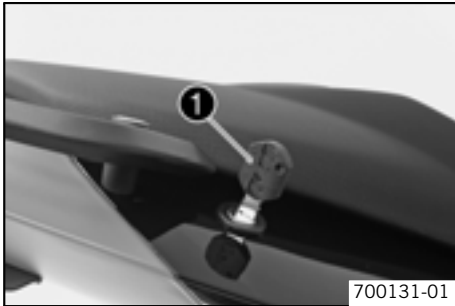

- Insert the ignition key in the seat lock ❶ and turn it 45° counterclockwise.
- Lift up the seat at the rear, pull it back and remove from above.

Mounting the seat

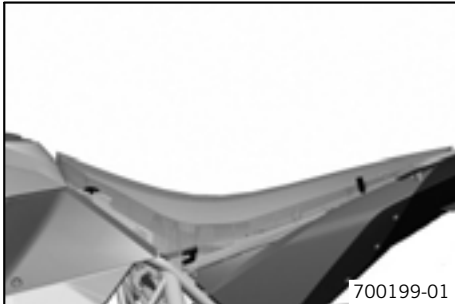

- Suspend the seat on the screw ❶, press the rear downwards and at the same time push it forwards. The two projections ❷ must be inserted into the frame.
- Push the locking pin ❸ into the lock housing and push the back of the seat down until the locking pin locks in place with an audible click.
- Remove the ignition key from the seat lock.
- Finally, check that the seat is correctly mounted.

Reinstalling the fuel tank

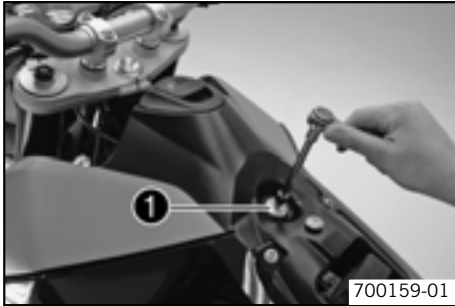

- Remove the seat. (☛ P. 87)
- Remove screw ❶.



Info

The fuel lines do not need to be disconnected.

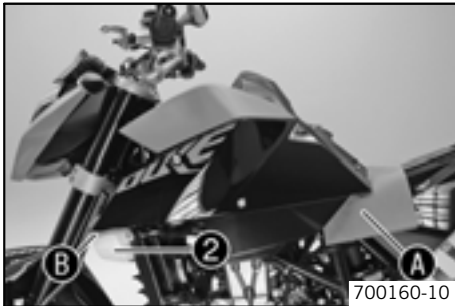

- Lay a cloth **A** over the subframe and straighten the steering.
- Carefully raise the fuel tank and move it backwards.
- Place the fuel tank on the vehicle so that the left spoiler is still lying on the compensating tank **2** (see illustration). Place a cloth **B** between the compensating tank and the spoiler to prevent damage.

Positioning the fuel tank

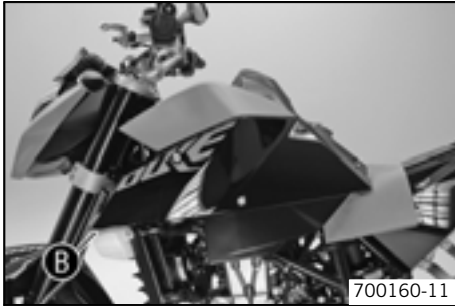

- Remove the cloth **B** from between the compensating tank and the spoiler.

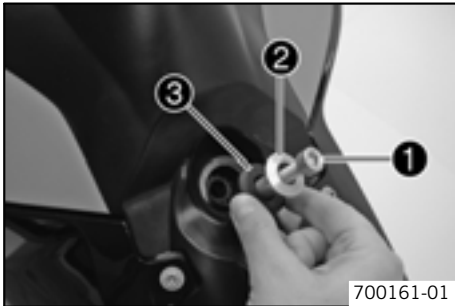

- Carefully move the fuel tank forwards and lower it.
- Mount and tighten screw **1** with bearing sleeve **2** and rubber bushing **3**. Check fuel tank for tight fitting.

Specification

Screw, fuel tank bracket	M8	15 Nm (11.1 lbf ft)
--------------------------	----	---------------------

- Check the routing of the fuel hoses.
- Mount the seat. (☛ P. 87)

Removing the battery ↩



Warning

Risk of injury Battery acid and battery gases cause serious cauterization.

- Keep batteries out of the reach of children.
- Wear suitable protective clothing and goggles.
- Avoid contact with battery acid and battery gases.
- Keep the battery away from sparks or open fire. Charge only in well ventilated rooms.
- In the event of skin contact, rinse with large amounts of water. If battery acid gets in the eyes, rinse with water for at least 15 minutes and contact a doctor.

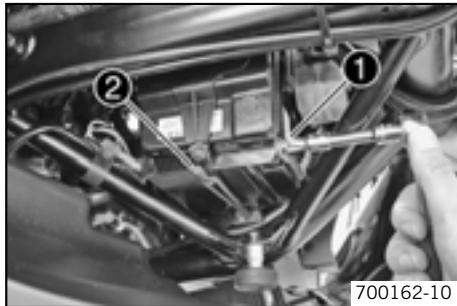

- Remove the seat. (↩ P. 87)
- Reinstall the fuel tank. (↩ P. 88)
- Disconnect the negative (minus) cable ❶ of the battery.
- Detach rubber band ❷.

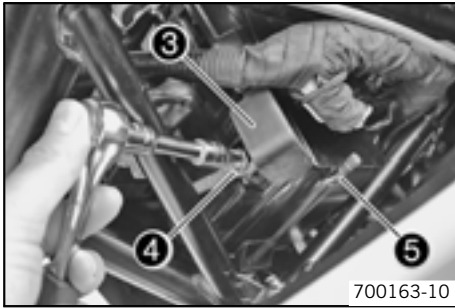

- Fold up positive terminal cover ③.
- Disconnect the positive (plus) cable ④ of the battery.
- Detach rubber band ⑤.

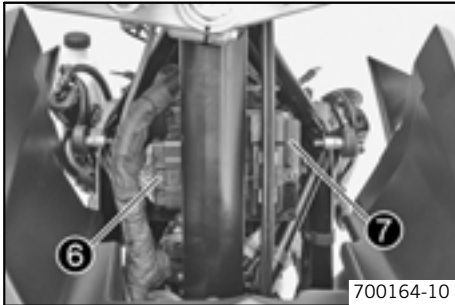

- Disconnect plug-in connector ⑥.
- Remove cover ⑦.



- Pull battery ⑧ up and out of the battery rack. Take the battery out of the frame toward the right.

i **Info**

Never operate the motorcycle with a discharged battery or without a battery. In both cases, electrical components can safety equipment can be damaged. The vehicle is then no longer safe to ride.

Installing the battery



- Push battery ❶ from the right into the frame. Position the battery in the battery rack.



Info

The battery terminals must be at the front.

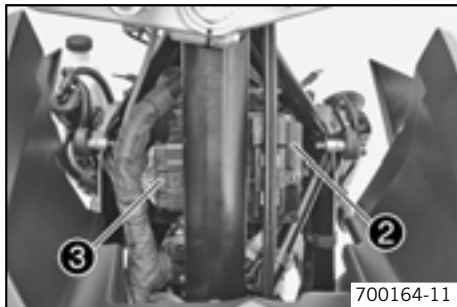

- Position cover ❷.
- Connect plug-in connector ❸.

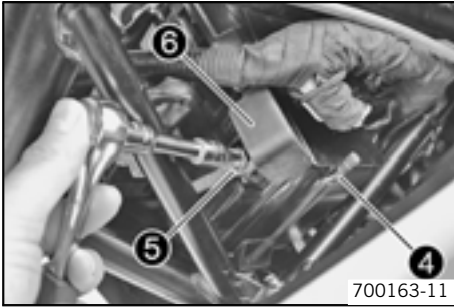

- Secure the cover with rubber band ④.
- Connect positive cable ⑤. Position positive terminal cover ⑥.

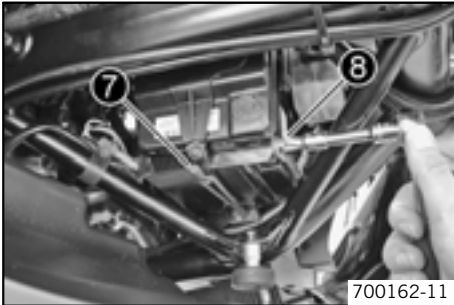

- Secure the cover with rubber band ⑦.
- Attach the minus cable ⑧.
- Position the fuel tank. (☞ P. 89)
- Mount the seat. (☞ P. 87)
- Set the clock. (☞ P. 28)

Recharging the battery



Warning

Risk of injury Battery acid and battery gases cause serious cauterization.

- Keep batteries out of the reach of children.
- Wear suitable protective clothing and goggles.
- Avoid contact with battery acid and battery gases.
- Keep the battery away from sparks or open fire. Charge only in well ventilated rooms.
- In the event of skin contact, rinse with large amounts of water. If battery acid gets in the eyes, rinse with water for at least 15 minutes and contact a doctor.



Warning

Environmental hazard Components and battery acid are a danger to the environment.

- Do not dispose of batteries in normal household waste. Take defective or used batteries to a battery recycling operator.



Warning

Environmental hazard Problem materials cause environmental damage.

- Dispose of oil, grease, filters, fuel, cleaning substances, brake fluid, batteries, etc. according to regulations.



Info

Even if there is no load on the battery, it loses power every day.

The charge state and the type of charge are very important for the service life of the battery.

Fast recharging with a high charge current shortens the battery's service life.

If the charge current, the charge voltage and the charge time are exceeded, electrolyte escapes through the breathing holes. The battery capacity is then reduced.

If the battery is discharged from starting, it must be recharged immediately.

If it stands for a long time in a discharged state, the battery becomes over-discharged and sulfated, and then it is destroyed.

The battery is maintenance-free, i.e., the acid level does not have to be checked.

- Switch off all power-consuming components and switch off the engine.
- Reinstall the fuel tank. (☛ P. 88)
- Disconnect the minus (negative) cable of the battery to avoid damage to the motorcycle's electronics.
- Connect the battery charger to the battery. Switch on the battery charger.

Battery charger (58429074000)

You can also use the battery charger to test rest potential and start potential of the battery, and to test the generator. With this device, you cannot overcharge the battery.

i Info

Never remove the lid ❶.

Charge the battery according to the instructions ❷ on the battery casing.

- Switch off the charger after charging. Disconnect the battery.

Specification

The charge current, charge voltage and charge time must not be exceeded.

Charge the battery regularly when the motorcycle is not in use.

3 months

- Position the fuel tank. (☛ P. 89)
- Mount the seat. (☛ P. 87)
- Set the clock. (☛ P. 28)



Changing the main fuse



Warning

Fire hazard The electrical system can be overloaded by the use of incorrect fuses.

- Use only fuses with the prescribed amperage. Never by-pass or repair fuses.



Info

The main fuse protects all power-consuming components of the vehicle. It is located in the housing of the electric starter relay next to the battery.

- Switch off all power-consuming components and switch off the engine.
- Remove the seat. (🔧 P. 87)
- Reinstall the fuel tank. (🔧 P. 88)
- Remove the protection cover ❶.



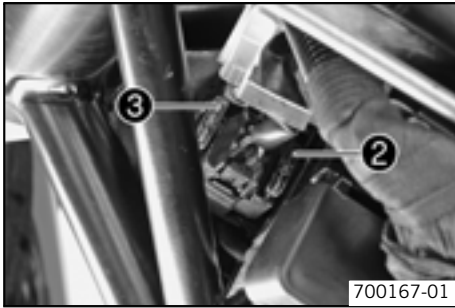

- Remove a defective main fuse ② with a needle nose plier.
- Check parts for damage and wear. Replace damaged or worn parts.

i **Info**

A reserve fuse ③ is located in the starter relay.

-
- Fit a new main fuse.

Fuse (58011109130) (☞ P. 153)

i **Info**

If the new fuse burns out, contact an authorized KTM workshop.

-
- Replace protection cover ①.
 - Position the fuel tank. (☞ P. 89)
 - Mount the seat. (☞ P. 87)
 - Set the clock. (☞ P. 28)

Changing fuses of individual power consumers

i **Info**

The fuse box containing the fuses of individual power consumers is located under the seat.

-
- Switch off all power-consuming components and switch off the engine.
 - Remove the seat. (☞ P. 87)

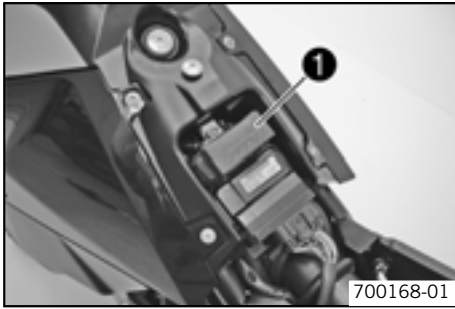

- Open the fuse box cover ❶.



- Remove defective fuse.

Specification

Fuse 1 - 10A - ignition, combination instrument, alarm system (optional)
Fuse 2 - 10A - clock, ignition (EFI control unit)
Fuse 3 - 10A - throttle valve control unit
Fuse 4 - 10A - fuel pump
Fuse 5 - 10A - radiator fan
Fuse 6 - 10A - horn, brake light, flasher light, alarm system (optional)
Fuse 7 - 15A - high beam, low beam, parking light, tail light, license plate lamp
Fuse 8 - 10A - for supplementary equipment (accessories connected with ignition switch)
Fuse 9 - 10A - for supplementary equipment (standard accessories)
Fuse 10 - not used
Fuse SPARE - 10A/15A - spare fuses

- Check parts for damage and wear. Replace damaged or worn parts.

**Info**

A defective fuse is shown by a burned-out fuse wire .

**Warning**

Fire hazard The electrical system can be overloaded by the use of incorrect fuses.

- Use only fuses with the prescribed amperage. Never by-pass or repair fuses.
-
- Use spare fuses with the correct rating only.

Fuse (75011088010) ( P. 153)
--

Fuse (75011088015) ( P. 153)
--

**Info**

If the new fuse burns out, contact an authorized KTM workshop.

**Tip**

Replace the spare fuse in the fuse box so that it will be available if needed.

-
- Close the fuse box cover.
 - Mount the seat. ( P. 87)

Adjusting the engine characteristics

- Turn the ignition key to the position .

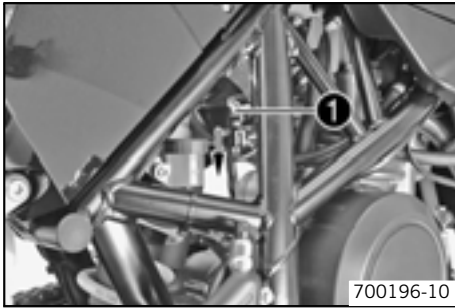

- **Map-Select** Pull the switch with holder ❶ downward off of the retaining bracket.

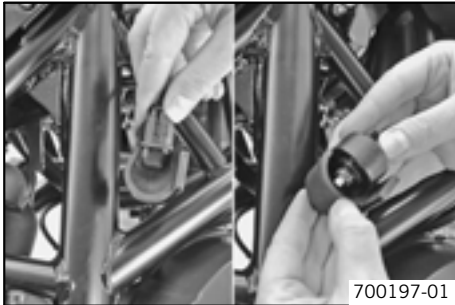

- **Map-Select** Position the switch on the outside of the frame.
- **Map-Select** Pull the switch out of the holder.

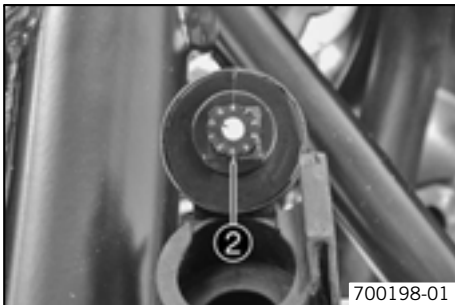

- Turn the adjusting wheel until the desired number is adjacent to marking ❷.



Info

Position 0 has no function.

Map-Select Set the switch to Soft.

- Set the adjusting wheel to position 1.
 - ✓ Soft – Greater flexibility

Map-Select Set the switch to Performance.

- Set the adjusting wheel to position **2**.
 - ✓ Performance – Higher performance

Map-Select Set the switch to Standard.

- Set the adjusting wheel to position **3, 4, 5, 6, 7, 8 or 9**.
 - ✓ Standard
- **Map-Select** Position the switch in the holder.
- **Map-Select** Push the switch with the holder upward onto the retaining bracket.

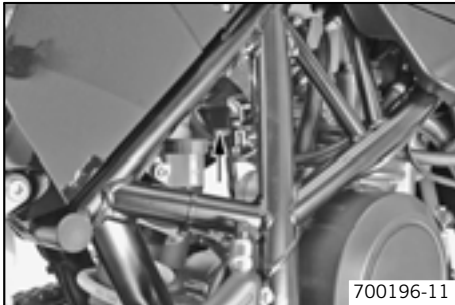

Removing headlight mask with headlight

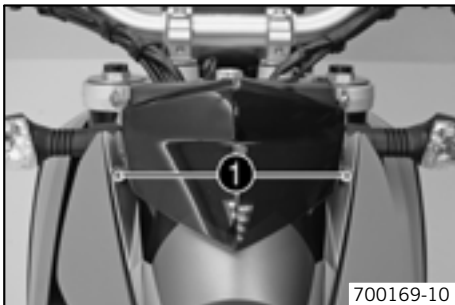

- Remove screws **1**.

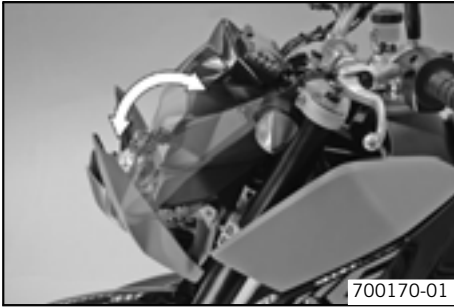

- Swing the headlight mask forward.

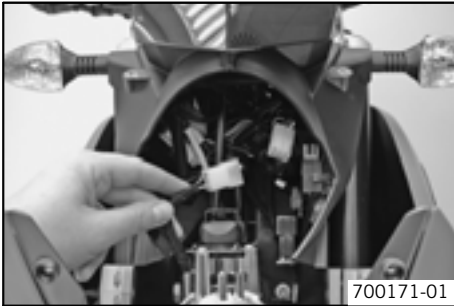

- Disconnect plug-in connector.



- Remove the screw fitting ② on both sides.
- Place the headlight mask to one side.

Refitting the headlight mask with the headlight



- Position the headlight mask. Mount and tighten screws ❶ on both sides.

Specification

Screw, headlight mask	M6	5 Nm (3.7 lbf ft)
-----------------------	----	-------------------

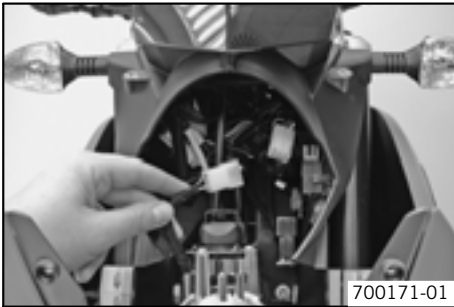

- Connect the plug-in connector.

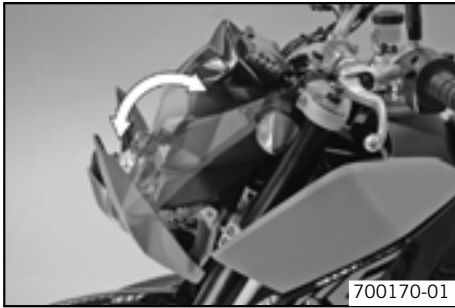

- Swing the headlight mask upward.

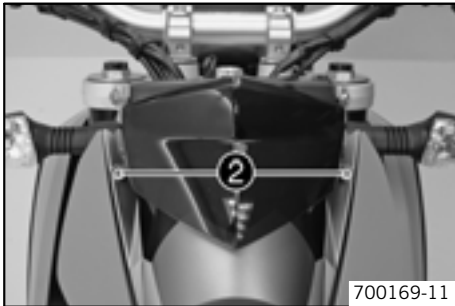

- Position the headlight mask. Mount and tighten screws ②.

Specification

Screw, headlight mask	M6	5 Nm (3.7 lbf ft)
-----------------------	----	-------------------

- Check lighting function.

Changing the low beam bulb

Note

Damage to reflector Keep the glass of the bulb free of grease.

- After fitting the bulb in the holder, clean the glass with a clean cloth. Any grease on the glass will evaporate by the heat and be deposited on the reflector.

- Switch off all power-consuming components and switch off the engine.

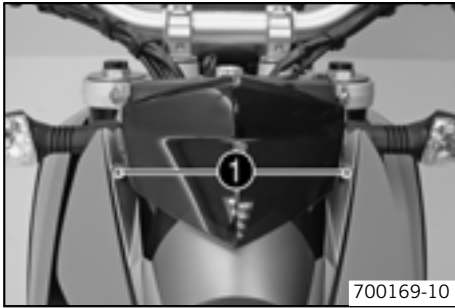

- Remove screws ❶.

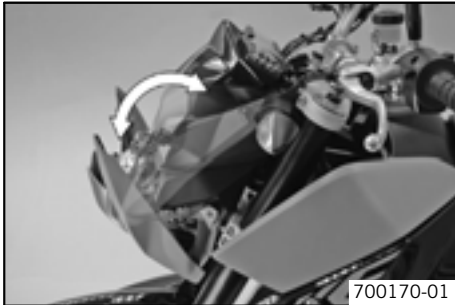

- Swing the headlight mask forward.

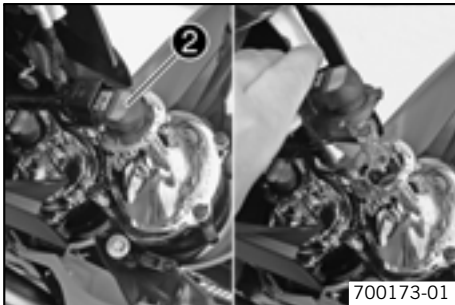

- Turn headlight lamp ❷ counterclockwise and remove it.
- Check parts for damage and wear. Replace damaged or worn parts.
- Position the new headlight bulb in the headlight housing.

Low beam/high beam (HB3/P20d) (☞ P. 153)



Info

Insert the headlight bulb so that the bayonet lugs latch into the slots.

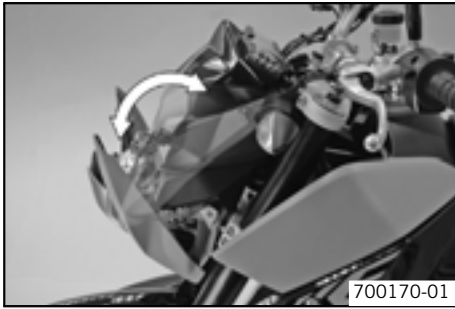

- Swing the headlight mask upward.

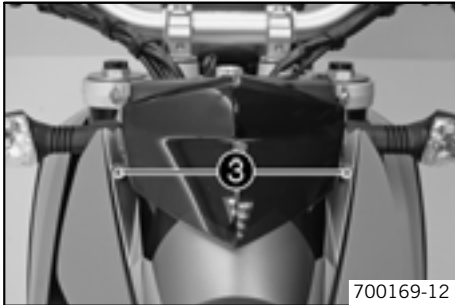

- Position the headlight mask. Mount and tighten screws ③.

Specification

Screw, headlight mask	M6	5 Nm (3.7 lbf ft)
-----------------------	----	-------------------

- Check lighting function.

Changing the high beam bulb

Note

Damage to reflector Keep the glass of the bulb free of grease.

- After fitting the bulb in the holder, clean the glass with a clean cloth. Any grease on the glass will evaporate by the heat and be deposited on the reflector.

- Switch off all power-consuming components and switch off the engine.

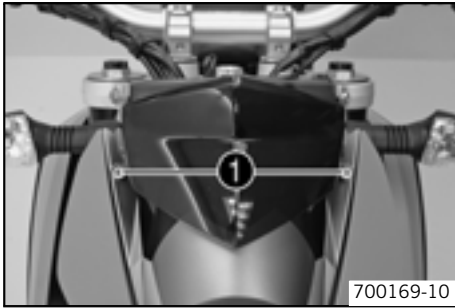

- Remove screws ❶.

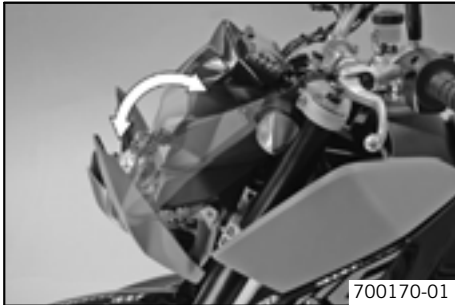

- Swing the headlight mask forward.

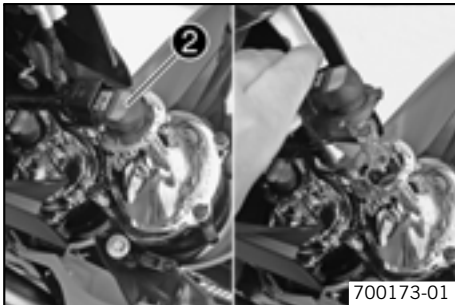

- Turn headlight lamp ❷ counterclockwise and remove it.
- Check parts for damage and wear. Replace damaged or worn parts.
- Position the new headlight bulb in the headlight housing.

Low beam/high beam (HB3/P20d) (☞ P. 153)



Info

Insert the headlight bulb so that the bayonet lugs latch into the slots.

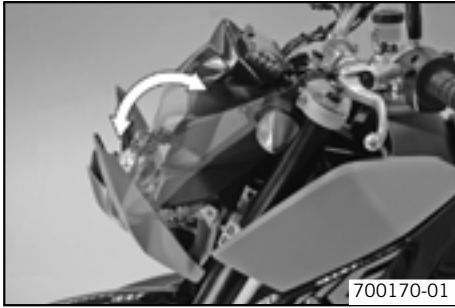

700170-01

- Swing the headlight mask upward.

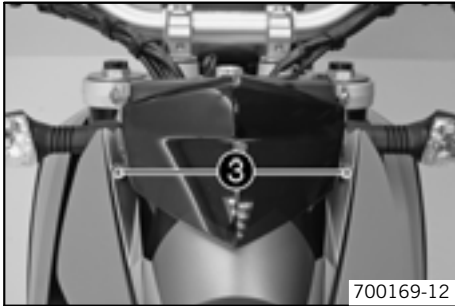

700169-12

- Position the headlight mask. Mount and tighten screws ③.

Specification

Screw, headlight mask	M6	5 Nm (3.7 lbf ft)
-----------------------	----	-------------------

- Check lighting function.

Changing the parking light bulb

Note

Damage to reflector Keep the glass of the bulb free of grease.

- After fitting the bulb in the holder, clean the glass with a clean cloth. Any grease on the glass will evaporate by the heat and be deposited on the reflector.

- Switch off all power-consuming components and switch off the engine.

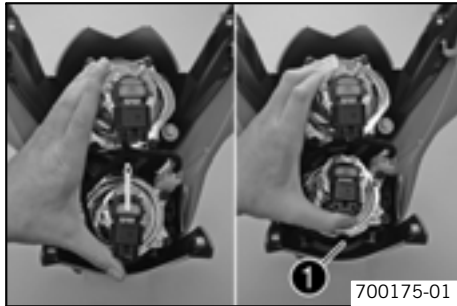

- Remove the headlight mask with the headlight. (☛ P. 101)
- Set down the headlight mask in front of you as shown in the illustration and carefully tilt the high beam headlight in the direction of the low beam headlight.
- Turn the bulb holder ❶ about 30° counterclockwise and remove it.

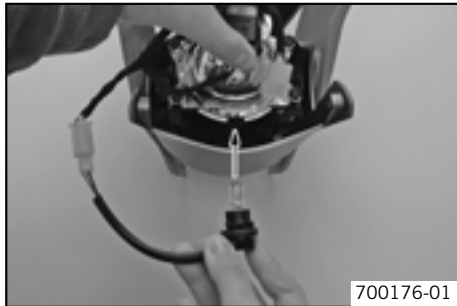

- Pull the parking light bulb out of the holder.
- Check parts for damage and wear. Replace damaged or worn parts.
- Insert a new parking light bulb in the holder.

Parking light (W2, 1x9,5d) (☛ P. 153)

- Position the bulb holder and turn it clockwise as far as it will go.
- Refit the headlight mask with the headlight. (☛ P. 103)

Changing the flasher bulb

Note

Damage to reflector Keep the glass of the bulb free of grease.

- After fitting the bulb in the holder, clean the glass with a clean cloth. Any grease on the glass will evaporate by the heat and be deposited on the reflector.

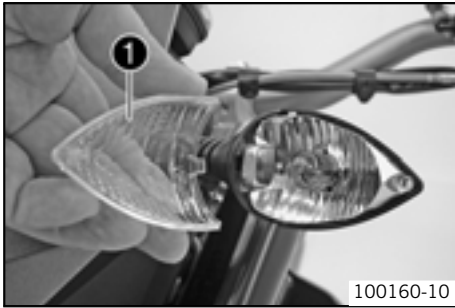

- Remove the screw on the rear of the flasher housing.
- Carefully swing the diffuser ❶ forwards and remove it.
- Press the flasher bulb carefully into the holder, turn it about 30° counterclockwise and remove it from the holder.



Info

Do not touch the reflector with your fingers and try to avoid contact with oil or grease.

- Check parts for damage and wear. Replace damaged or worn parts.
- Press the new flasher bulb carefully into the holder and turn it clockwise as far as it will go.

Flasher light (BAU15s) (☛ P. 153)

- Position the diffuser.
- Insert the screw and turn it first counterclockwise until you feel it click into the thread. Tighten the screw.
- Check the flasher function.

Checking the low beam headlight adjustment

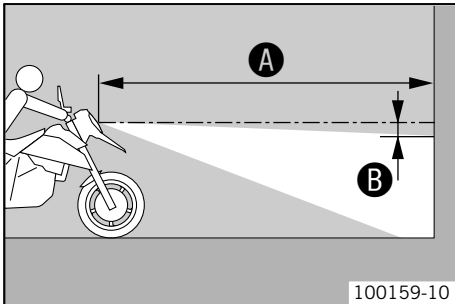

- On a light-colored wall behind a horizontal area, make a mark as high as the center of the low beam headlight.
- Make another mark at a distance of ❷ under the first mark.

Specification

Distance ❷	5 cm (2 in)
------------	-------------

- Stand the motorcycle at a distance of ❶ in front of the wall and switch on the ignition.

Specification

Distance ❶	5 m (16 ft)
------------	-------------

- Check the low beam headlight adjustment.

The boundary between light and dark must be exactly on the lower mark for a motorcycle with driver.

- » If the boundary between light and dark does not meet specifications:
 - Adjust the light range of the low beam headlight. (☛ P. 112)

Checking the high beam headlight adjustment

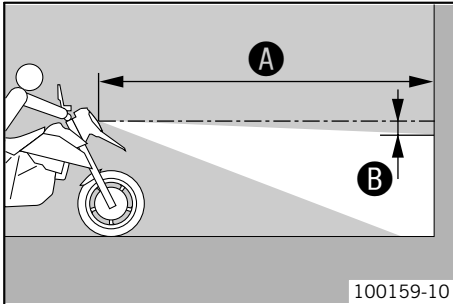

- On a light-colored wall behind a horizontal area, make a mark as high as the center of the high beam headlight.
- Make another mark at a distance of **B** under the first mark.

Specification

Distance B	5 cm (2 in)
-------------------	-------------

- Stand the motorcycle at a distance of **A** in front of the wall and switch on the high beam.

Specification

Distance A	5 m (16 ft)
-------------------	-------------

- Check the high beam headlight adjustment.

The boundary between light and dark must be exactly on the lower mark for a motorcycle with driver.

- » If the boundary between light and dark does not meet specifications:
 - Adjust the light range of the high beam headlight. (☛ P. 114)

Adjusting the light range of the low beam headlight

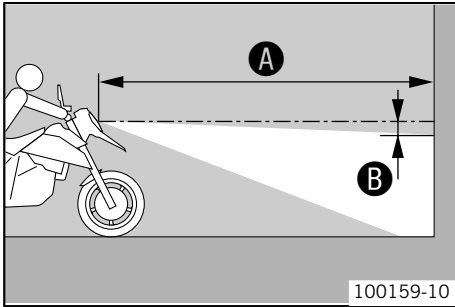

- On a light-colored wall behind a horizontal area, make a mark as high as the center of the low beam headlight.
- Make another mark at a distance of **B** under the first mark.

Specification

Distance B	5 cm (2 in)
-------------------	-------------

- Stand the motorcycle at a distance of **A** in front of the wall and switch on the low beam.

Specification

Distance A	5 m (16 ft)
-------------------	-------------

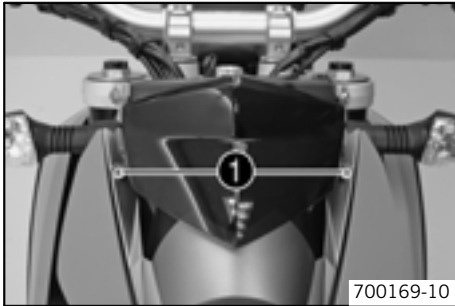

- Remove screws **1**.
- Swing the headlight mask forward.

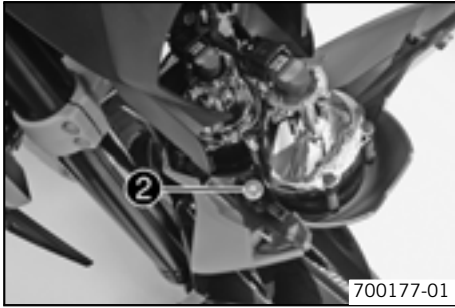

- Adjust the light range of the headlight by turning screw ②.

Specification

The boundary between light and dark must be exactly on the lower mark for a motorcycle with driver.

i Info

Turn clockwise to increase the light range, turn counterclockwise to reduce the light range.

If you have a payload, you may have to correct the headlight range.

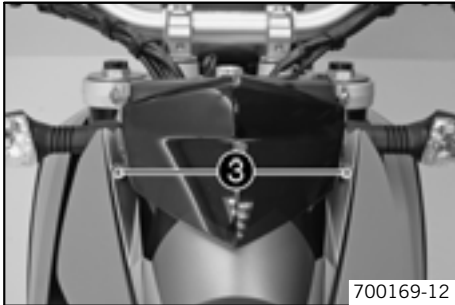

- Swing the headlight mask upward.
- Position the headlight mask. Mount and tighten screws ③.

Specification

Screw, headlight mask	M6	5 Nm (3.7 lbf ft)
-----------------------	----	-------------------

- Check the low beam head light adjustment. (☞ P. 110)
 - » If the boundary between light and dark does not meet specifications:
 - Adjust the light range of the low beam headlight. (☞ P. 112)

Adjusting the light range of the high beam headlight

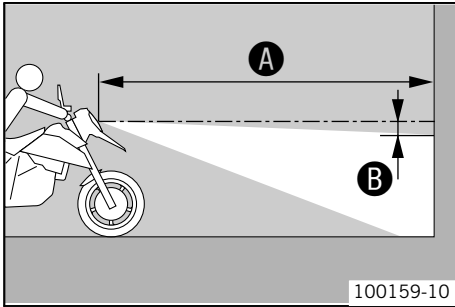

- On a light-colored wall behind a horizontal area, make a mark as high as the center of the high beam headlight.
- Make another mark at a distance of **B** under the first mark.

Specification

Distance B	5 cm (2 in)
-------------------	-------------

- Stand the motorcycle at a distance of **A** in front of the wall and switch on the high beam.

Specification

Distance A	5 m (16 ft)
-------------------	-------------

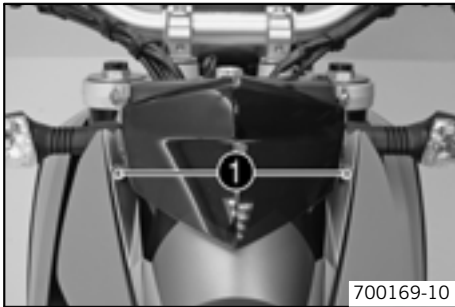

- Remove screws **1**.
- Swing the headlight mask forward.



- Adjust the beam distance of the headlight by turning screw ②.

Specification

The boundary between light and dark must be exactly on the lower mark for a motorcycle with driver.

i Info

Turn clockwise to increase the light range, turn counterclockwise to reduce the light range.

If you have a payload, you may have to correct the headlight range.

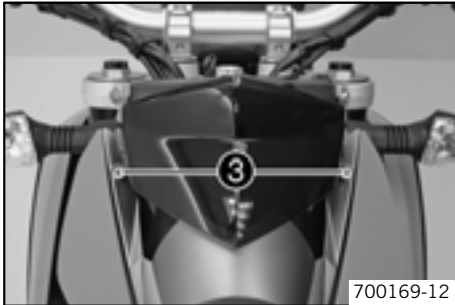

- Swing the headlight mask upward.
- Position the headlight mask. Mount and tighten screws ③.

Specification

Screw, headlight mask	M6	5 Nm (3.7 lbf ft)
-----------------------	----	-------------------

- Check the high beam headlight adjustment. (☛ P. 111)
 - » If the boundary between light and dark does not meet specifications:
 - Adjust the light range of the high beam headlight. (☛ P. 114)

Cooling system



The water pump ❶ in the engine forces the coolant to flow.

The pressure resulting from the warming of the cooling system is regulated by a valve in the radiator cap ❷. Heat expansion causes excess coolant to flow into the compensating tank ❸. If the temperature falls, the excess coolant is sucked back into the cooling system. The specified coolant temperature is therefore permissible without danger of function problems.

125 °C (257 °F)

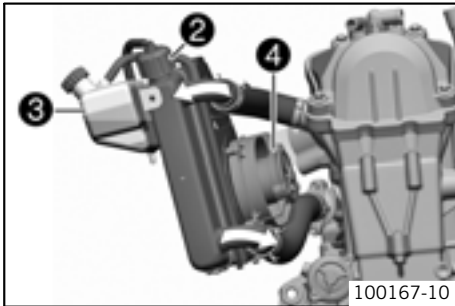

The coolant is cooled by the air stream and a radiator fan ❹, which is controlled by a thermostat.

The lower the speed, the less the cooling effect. Dirty cooling fins also reduce the cooling effect.

Checking antifreeze and coolant level



Warning

Danger of scalding The coolant gets very hot when the motorcycle is driven and is under high pressure.

- Do not open the radiator, radiator hoses or other cooling system components when the engine is hot. Allow the engine and cooling system to cool down. If you scald yourself, hold the affected area under cold water immediately.



Warning

Danger of poisoning Coolants are poisonous and a health hazard.

- Avoid contact between coolants and skin, eyes and clothing. If fuel gets into your eyes, rinse immediately with water and contact a doctor. Wash affected skin areas immediately with soap and water. If coolant is swallowed, contact a doctor immediately. Change clothes that have come into contact with coolants. Keep coolants out of the reach of children.

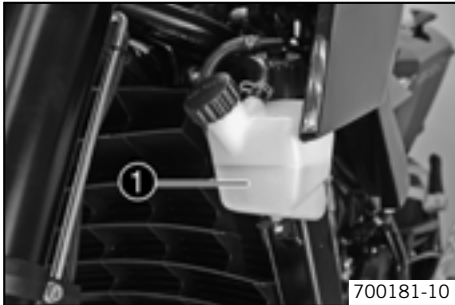

- Remove the seat. (🔧 P. 87)
- Reinstall the fuel tank. (🔧 P. 88)

Condition

Engine is cold.

- Stand the motorcycle upright on a horizontal surface.
- Remove the cap of the compensating tank ❶.
- Check antifreeze of coolant.

-25... -45 °C (-13... -49 °F)

- » If the antifreeze of the cooling liquid does not meet specifications:
 - Correct antifreeze of coolant.

- Check the coolant level in the compensating tank.

The coolant level must be between **MIN** and **MAX**.

- » If the level of the cooling liquid does not meet specifications:
 - Correct the coolant level.

Alternative 1

Coolant (🔧 P. 162)

Alternative 2

Coolant (mixed ready to use) (🔧 P. 162)

- Replace the cap of the compensating tank.



- Screw off the radiator cap ②.
- Check antifreeze of coolant.

-25... -45 °C (-13... -49 °F)

- » If the antifreeze of the cooling liquid does not meet specifications:
 - Correct antifreeze of coolant.

- Check the coolant level in the radiator.

The radiator must be completely full.

- » If the level of the cooling liquid does not meet specifications:
 - Correct the coolant level and find out the cause of the loss.

Alternative 1

Coolant (☞ P. 162)

Alternative 2

Coolant (mixed ready to use) (☞ P. 162)

- » If you have to add more coolant than the specified value:
 - > 0.50 l (> 0.53 qt.)
 - Fill/bleed the cooling system. ☞ (☞ P. 121)
- Refit the radiator cap.
- Position the fuel tank. (☞ P. 89)
- Mount the seat. (☞ P. 87)

Checking the coolant level



Warning

Danger of scalding The coolant gets very hot when the motorcycle is driven and is under high pressure.

- Do not open the radiator, radiator hoses or other cooling system components when the engine is hot. Allow the engine and cooling system to cool down. If you scald yourself, hold the affected area under cold water immediately.



Warning

Danger of poisoning Coolants are poisonous and a health hazard.

- Avoid contact between coolants and skin, eyes and clothing. If fuel gets into your eyes, rinse immediately with water and contact a doctor. Wash affected skin areas immediately with soap and water. If coolant is swallowed, contact a doctor immediately. Change clothes that have come into contact with coolants. Keep coolants out of the reach of children.

- Remove the seat. (☞ P. 87)
- Reinstall the fuel tank. (☞ P. 88)

Condition

Engine is cold.

- Stand the motorcycle upright on a horizontal surface.
- Check the coolant level in the compensating tank ❶.

The coolant level must be between **MIN** and **MAX**.

- » If the level of the cooling liquid does not meet specifications:
 - Correct the coolant level.

Alternative 1

Coolant (☞ P. 162)

Alternative 2

Coolant (mixed ready to use) (☞ P. 162)

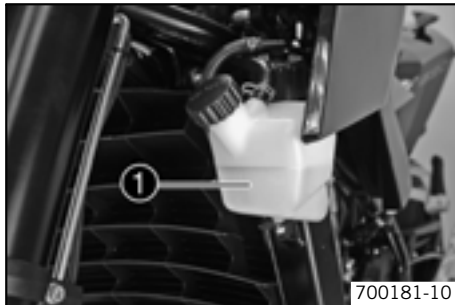



- Screw off the radiator cap ② and check the coolant level in the radiator.

The radiator must be completely full.

- » If the level of the cooling liquid does not meet specifications:
 - Correct the coolant level and find out the cause of the loss.

Alternative 1

Coolant (☞ P. 162)

Alternative 2

Coolant (mixed ready to use) (☞ P. 162)

- » If you have to add more coolant than the specified value:
 - > 0.50 l (> 0.53 qt.)
 - Fill/bleed the cooling system. 🛠️ (☞ P. 121)
- Refit the radiator cap.
- Position the fuel tank. (☞ P. 89)
- Mount the seat. (☞ P. 87)

Draining coolant 🛠️



Warning

Danger of scalding The coolant gets very hot when the motorcycle is driven and is under high pressure.

- Do not open the radiator, radiator hoses or other cooling system components when the engine is hot. Allow the engine and cooling system to cool down. If you scald yourself, hold the affected area under cold water immediately.



Warning

Danger of poisoning Coolants are poisonous and a health hazard.

- Avoid contact between coolants and skin, eyes and clothing. If fuel gets into your eyes, rinse immediately with water and contact a doctor. Wash affected skin areas immediately with soap and water. If coolant is swallowed, contact a doctor immediately. Change clothes that have come into contact with coolants. Keep coolants out of the reach of children.

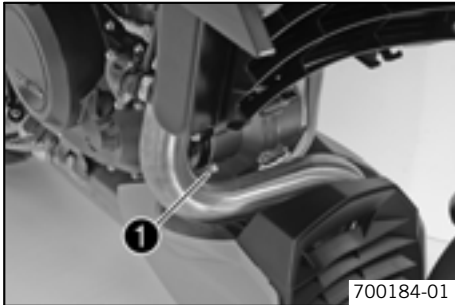

- Remove the seat. (☛ P. 87)
- Reinstall the fuel tank. (☛ P. 88)
- Stand the vehicle upright.
- Place a suitable container under the engine.
- Remove screw ❶. Remove the radiator cap.
- Completely drain the coolant.
- Fit screw ❶ with a new seal and tighten it.

Specification

Plug, drain hole of water pump	M10x1	15 Nm (11.1 lbf ft)
--------------------------------	-------	---------------------

Filling/bleeding the cooling system 🛠️



Warning

Danger of poisoning Coolants are poisonous and a health hazard.

- Avoid contact between coolants and skin, eyes and clothing. If fuel gets into your eyes, rinse immediately with water and contact a doctor. Wash affected skin areas immediately with soap and water. If coolant is swallowed, contact a doctor immediately. Change clothes that have come into contact with coolants. Keep coolants out of the reach of children.

- Remove the seat. (☛ P. 87)
- Reinstall the fuel tank. (☛ P. 88)



- Remove the radiator cap ❶ and the bleeder screw ❷.
- Tilt the vehicle slightly to the right.

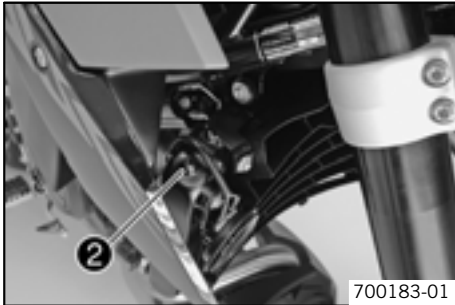

- Pour coolant in until it overflows free of bubbles, and then replace the bleeder screw immediately.

Alternative 1

Coolant (☞ P. 162)

Alternative 2

Coolant (mixed ready to use) (☞ P. 162)

- Fill the radiator completely with coolant. Refit the radiator cap.
- Place the vehicle on the side stand. Point the fuel tank forwards.



Danger

Danger of poisoning Exhaust gases are poisonous and can result in unconsciousness and/or death.

- When running the engine, always make sure there is sufficient ventilation, and do not start or run the engine in a closed space.
-
- Start the engine and run it until the 5th bar of the temperature indicator lights up.

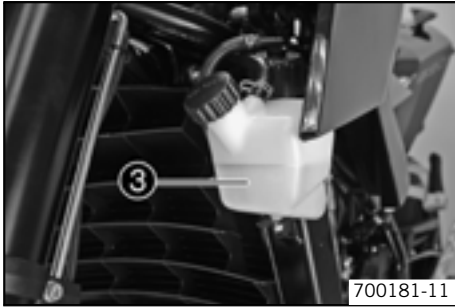

- Switch off the engine and allow it to cool down.
- After the engine has cooled down, check the coolant level in the radiator again and add more coolant if necessary.
- Remove the cap of the compensating tank ③ and top up the coolant level up to the **MAX** marking. Replace the cap of the compensating tank.
- Position the fuel tank. (☛ P. 89)
- Mount the seat. (☛ P. 87)

Adjusting basic position of clutch lever



Info

Turn the adjusting screw clockwise to increase the distance between the clutch lever and the handlebar.
Turn the adjusting screw counterclockwise to decrease the distance between the clutch lever and the handlebar.
The range of adjustment is limited.
Turn the adjusting screw by hand only, and do not apply any force.
Do not make any adjustments while riding!

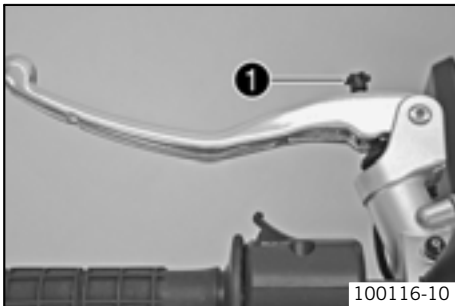

- Adjust the basic setting of the clutch lever to your hand size by turning adjusting screw ①.

Checking/correcting fluid level of hydraulic clutch



Info

The fluid level rises with increasing wear of the clutch lining disc.
Do not use brake fluid.

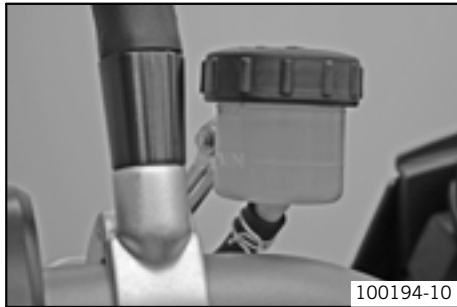

- Move the clutch fluid reservoir mounted on the handlebar to a horizontal position.
- Check the fluid level.

The fluid level must be between the **MIN** and **MAX** markings.

» If the fluid level does not meet specifications:

- Remove screw with membrane.
- Correct the fluid level of the hydraulic clutch.

Hydraulic fluid (15) (☛ P. 163)

- Check parts for damage and wear. Replace damaged or worn parts.
- Refit screw with membrane.

Checking play in gas Bowden cable

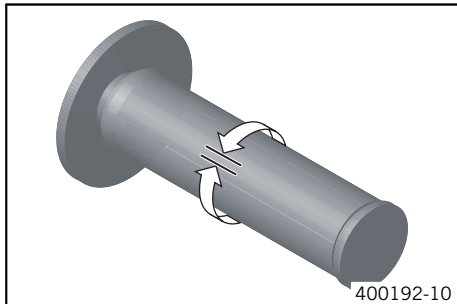

- Move the handlebar to the straight-ahead position. Move the throttle grip backwards and forwards to ascertain the play in the gas Bowden cable.

Play in gas Bowden cable

3... 5 mm (0.12... 0.2 in)

» If the gas Bowden cable play does not meet specifications:

- Adjust the play in the gas Bowden cable. ☛ (☛ P. 125)

**Danger**

Danger of poisoning Exhaust gases are poisonous and can result in unconsciousness and/or death.

- When running the engine, always make sure there is sufficient ventilation, and do not start or run the engine in a closed space.

- Start the engine and let it run idle. Move the handlebar to and fro over the entire steering range.

The idle speed must not change.

» If the idle speed changes:

- Adjust the play in the gas Bowden cable. 🛠️ (📄 P. 125)

Adjusting play in gas Bowden cable 🛠️

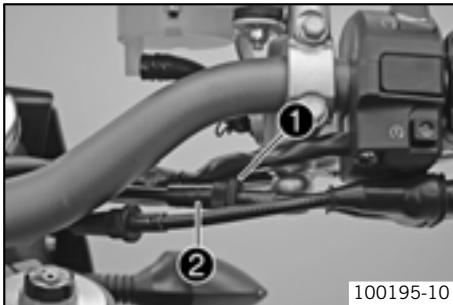

- Move the handlebar to the straight-ahead position.
- Loosen the lock nut ❶.
- Adjust the play in the gas Bowden cable by turning the adjusting screw ❷.

Specification

Play in gas Bowden cable	3... 5 mm (0.12... 0.2 in)
--------------------------	----------------------------

- Tighten the lock nut ❶.

Adjusting the handlebar angle

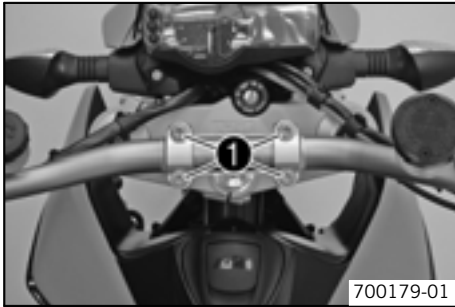

700179-01

- Loosen screw ❶.
- Move the handlebar to the desired position and slightly tighten the screws.
- Move the handlebar carefully in both directions as far as it will go.
 - » If the handlebar instruments touch the fuel tank:
 - Correct the handlebar angle.

Info

The distance between the handlebar support and the handlebar clamp must be the same at the front and rear.

- Fully tighten screw ❶.

Specification

Screw, handlebar clamp	M8	20 Nm (14.8 lbf ft)
------------------------	----	---------------------

Checking engine oil level

Info

The engine oil level must be checked when the engine is at operating temperature.

- Stand the motorcycle upright on a horizontal surface.

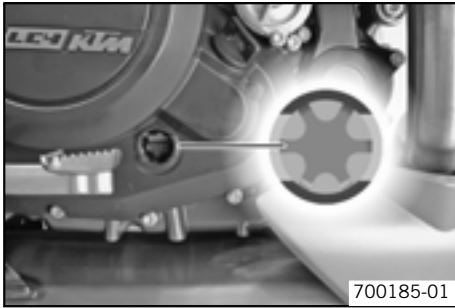

Condition

The engine is at operating temperature.

- Check the engine oil level.

Info

After switching off the engine, wait for one minute and then check.

The engine oil must be between the lower and upper edge of the oil level viewer.

- » If the engine oil level is not at the specified level:
 - Top up the engine oil. (☛ P. 134)

Changing engine oil and oil filter, cleaning oil screens 🛠️

- Drain the engine oil. 🛠️ (☛ P. 127)
- Remove the oil filter. 🛠️ (☛ P. 129)
- Clean oil screens. 🛠️ (☛ P. 131)
- Mount the oil filter. 🛠️ (☛ P. 131)
- Fill up with engine oil. 🛠️ (☛ P. 133)

Draining engine oil 🛠️



Warning

Danger of scalding Engine oil and gear oil get very hot when the motorcycle is driven.

- Wear suitable protective clothing and gloves. If you scald yourself, hold the affected area under cold water immediately.



Warning

Environmental hazard Problem materials cause environmental damage.

- Dispose of oil, grease, filters, fuel, cleaning substances, brake fluid, batteries, etc. according to regulations.



Info

Drain the engine oil only when the engine is warm.

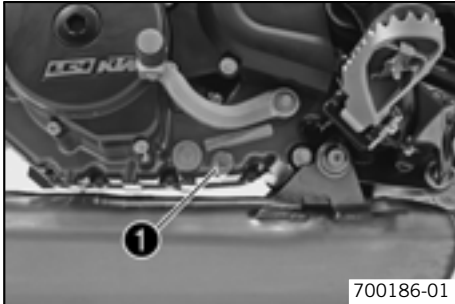

- Stand the motorcycle on its side stand on a horizontal surface.
- Place a suitable container under the engine.
- Remove the oil drain plug ❶ with the magnet and seal ring.
- Completely drain the engine oil.

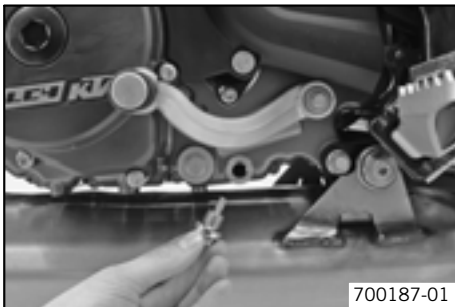

- Thoroughly clean the oil drain plug with a magnet.
- Check parts for damage and wear. Replace damaged or worn parts.
- Refit the oil drain plug with the magnet and seal ring and tighten it.

Specification

Oil drain plug with magnet	M12x1,5	20 Nm (14.8 lbf ft)
----------------------------	---------	---------------------

Removing the oil filter



Warning

Danger of scalding Engine oil and gear oil get very hot when the motorcycle is driven.

- Wear suitable protective clothing and gloves. If you scald yourself, hold the affected area under cold water immediately.



Warning

Environmental hazard Problem materials cause environmental damage.

- Dispose of oil, grease, filters, fuel, cleaning substances, brake fluid, batteries, etc. according to regulations.

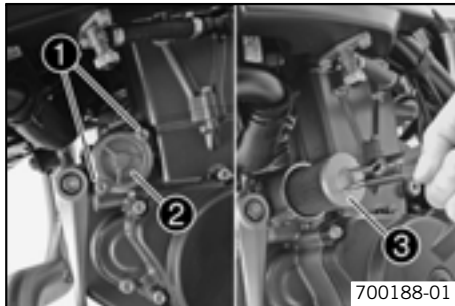

- Place a suitable container under the engine.
- Remove screws ①. Remove oil filter cover ② with O-ring.
- Pull the oil filter insert ③ out of the oil filter casing.

Circlip pliers reverse (51012011000)

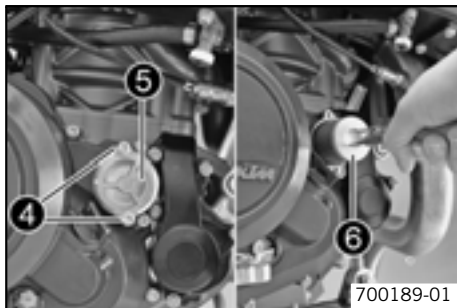

- Remove screws ④. Remove oil filter cover ⑤ with O-ring.
- Pull the oil filter insert ⑥ out of the oil filter casing.

Circlip pliers reverse (51012011000)

- Completely drain the engine oil.
- Thoroughly clean parts and sealing area.

Mounting oil filter

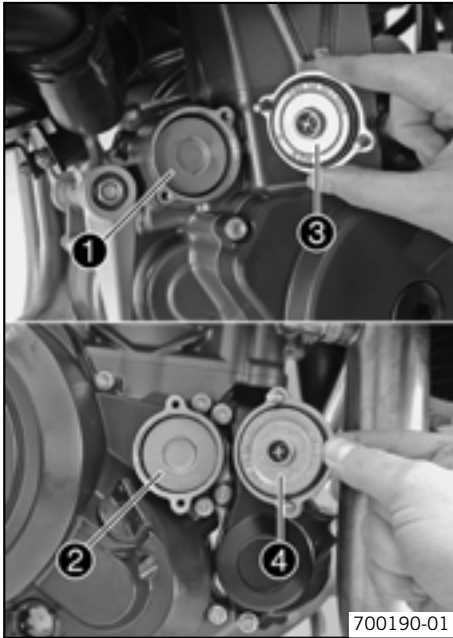

- Check parts for damage and wear. Replace damaged or worn parts.
- Insert oil filter **1** and **2**.
- Oil the O-rings of the oil filter cover. Refit the oil filter cover **3** and **4**.
- Mount and tighten screws.

Specification

Screw, oil filter cover	M5	6 Nm (4.4 lbf ft)
-------------------------	----	-------------------

Cleaning oil screens



Warning

Danger of scalding Engine oil and gear oil get very hot when the motorcycle is driven.

- Wear suitable protective clothing and gloves. If you scald yourself, hold the affected area under cold water immediately.



Warning

Environmental hazard Problem materials cause environmental damage.

- Dispose of oil, grease, filters, fuel, cleaning substances, brake fluid, batteries, etc. according to regulations.

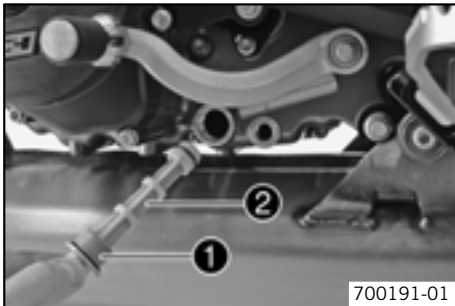

- Place a suitable container under the engine.
- Remove the plug ① with the oil screen ② and O-rings.

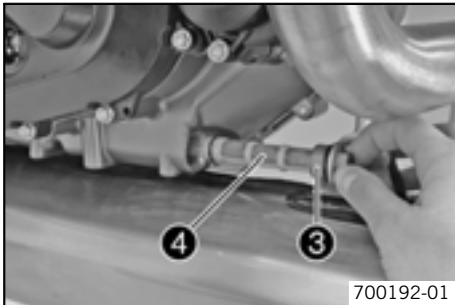

- Remove the plug ③ with the oil screen ④ and O-rings.
- Drain the remaining engine oil.
- Thoroughly clean parts and sealing area.
- Check parts for damage and wear. Replace damaged or worn parts.

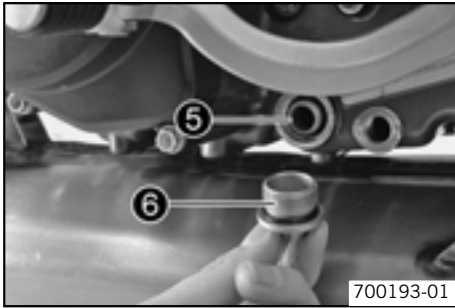

- Position oil screen ⑤ with O-rings.
- Refit plug ⑥ with O-ring and tighten it.

Specification

Plug, oil screen	M20x1,5	15 Nm (11.1 lbf ft)
------------------	---------	---------------------

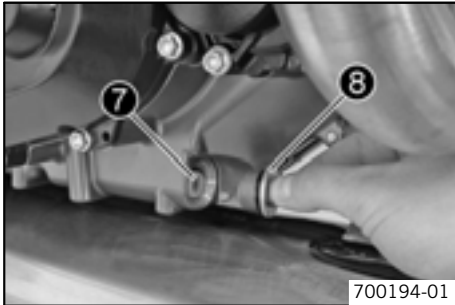

- Position oil screen ⑦ with O-rings.
- Refit plug ⑧ with O-ring and tighten it.

Specification

Plug, oil screen	M20x1,5	15 Nm (11.1 lbf ft)
------------------	---------	---------------------

Filling up with engine oil



Info

Too little engine oil or poor-quality engine oil results in premature wear to the engine.

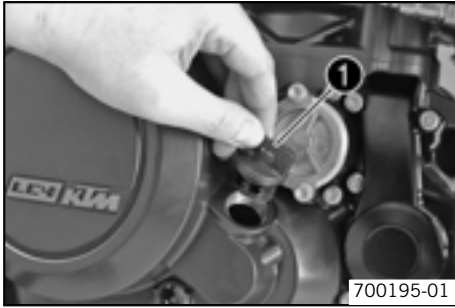

- Remove filler plug with O-ring ❶ from the clutch cover and add engine oil.

Engine oil	1.70 l (1.8 qt.)	Engine oil (SAE 10W/60) (☞ P. 163)
------------	------------------	------------------------------------

- Refit plug with O-ring ❶ and tighten it.



Danger

Danger of poisoning Exhaust gases are poisonous and can result in unconsciousness and/or death.

- When running the engine, always make sure there is sufficient ventilation, and do not start or run the engine in a closed space.
-
- Start the engine and check that it is oil-tight.
 - Check the engine oil level. (☞ P. 126)

Topping up engine oil



Info

Too little engine oil or poor-quality engine oil results in premature wear to the engine.



- Remove filler plug with O-ring ❶ from the clutch cover and add engine oil.

Engine oil (SAE 10W/60) (☞ P. 163)

- Refit plug with O-ring ❶ and tighten it.

**Danger**

Danger of poisoning Exhaust gases are poisonous and can result in unconsciousness and/or death.

- When running the engine, always make sure there is sufficient ventilation, and do not start or run the engine in a closed space.
-
- Start the engine and check that it is oil-tight.
 - Check the engine oil level. (☛ P. 126)

Faults	Possible cause	Measure
Engine does not turn when the electric starter button is pressed	Operating error	– Carry out the instructions for starting. (☛ P. 43)
	Battery discharged	– Recharge the battery. 🛡️ (☛ P. 94) – Check the cause of discharging.
	Fuse 1, 2, 3, or 4 blown	– Change the fuses of individual power consumers. (☛ P. 97)
	Main fuse burned out	– Change the main fuse. (☛ P. 96)
	Ignition/steering lock or emergency OFF switch defective	– Have ignition/steering lock or emergency OFF switch checked.
	Defect in safety start system	– Have the safety start system checked.
Engine turns only if the clutch lever is drawn	The vehicle is in gear	– Shift gear to neutral.
	The vehicle is in gear and the side stand is folded out	– Shift gear to neutral.
	Defect in safety start system	– Have the safety start system checked.
Engine turns although a gear is engaged	Defect in safety start system	– Have the safety start system checked.
Engine turns but does not start.	Operating error	– Carry out the instructions for starting. (☛ P. 43)
	Fuse 4 blown	– Change the fuses of individual power consumers. (☛ P. 97)
	Coupling of fuel hose connection not connected	– Reconnect coupling of fuel hose connection.
	Socket connector of cable harness oxidized	– Clean socket connector and treat it with contact spray.
	Defect in fuel injection system	– Read the error memory with the KTM diagnostics tool and correct the fault.
Engine has too little power.	Air filter very dirty	– Have the air filter changed.

Faults	Possible cause	Measure
Engine has too little power.	Fuel filter very dirty	– Have the fuel filter changed.
	Defect in fuel injection system	– Read the error memory with the KTM diagnostics tool and correct the fault.
Engine overheats.	Too little coolant in cooling system	– Check the cooling system for leakage. – Check the coolant level. (☛ P. 119)
	Radiator fins very dirty	– Clean radiator fins.
	Foam formation in cooling system	– Drain the coolant. 🛠️ (☛ P. 120)
		– Fill/bleed the cooling system. 🛠️ (☛ P. 121)
	Buckled or damaged radiator hose	– Have the radiator hose changed.
	Thermostat defective	– Have thermostat removed and checked. Specification Opening temperature: 70 °C (158 °F)
	Fuse 5 blown	– Change the fuses of individual power consumers. (☛ P. 97)
	Defect in radiator fan system	– Have the radiator fan system checked.
Air in cooling system	– Fill/bleed the cooling system. 🛠️ (☛ P. 121)	
FI warning lamp (MIL) lights/flashes	Defect in fuel injection system	– Read the error memory with the KTM diagnostics tool and correct the fault.
Engine dies during the journey	Lack of fuel	– Fill up with fuel. (☛ P. 51)
	Fuse 1 , 2 or 4 blown	– Change the fuses of individual power consumers. (☛ P. 97)
High oil consumption	Engine vent hose bent	– Route the vent hose without bends or replace it if necessary.

Faults	Possible cause	Measure
High oil consumption	Engine oil level too high	– Check the engine oil level. (☛ P. 126)
	Engine oil too thin (low viscosity)	– Change engine oil and oil filter, clean oil screens. ☛ (☛ P. 127)
Headlight and parking light not functioning	Fuse 7 blown	– Change the fuses of individual power consumers. (☛ P. 97)
Flasher light, brake light and horn not functioning	Fuse 6 blown	– Change the fuses of individual power consumers. (☛ P. 97)
Time is not (correctly) displayed	Fuse 2 blown	– Change the fuses of individual power consumers. (☛ P. 97)
		– Set the clock. (☛ P. 28)
Battery discharged	Ignition not switched off when vehicle was parked	– Recharge the battery. ☛ (☛ P. 94)
	Battery is not charged by generator	– Check charging voltage.
Combination instrument shows nothing in the display	Fuse 1 blown	– Change the fuses of individual power consumers. (☛ P. 97)
Speedometer in combination instrument not functioning	Speedometer cable harness damaged or plug oxidized	– Have the cable harness and plug checked.

Fault	Description	Possible cause	Measure
02	FI warning lamp (MIL) flashes briefly 2x	Malfunction in ignition pulse generator circuit	– Check the ignition pulse generator. 🛠️
06	FI warning lamp (MIL) flashes briefly 6x	Input signal from throttle valve sensor too low/high	– Check the throttle valve sensor. 🛠️
08	FI warning lamp (MIL) flashes briefly 8x	Input signal from throttle grip sensor too low/high	– Check the throttle grip sensor. 🛠️
09	FI warning lamp (MIL) flashes briefly 9x	Input signal from pressure sensor of induction manifold too low/high	– Check the pressure sensor of the induction manifold. 🛠️
12	FI warning lamp (MIL) flashes 1x long, 2x short	Input signal from coolant temperature sensor too low/high	– Check the temperature sensor coolant. 🛠️
13	FI warning lamp (MIL) flashes 1x long, 3x short	Input signal from intake air temperature sensor too low/high	– Check the intake air temperature sensor. 🛠️
14	FI warning lamp (MIL) flashes 1x long, 4x short	Input signal from ambient air pressure sensor too low/high	– Check the ambient air pressure sensor. 🛠️
15	FI warning lamp (MIL) flashes 1x long, 5x short	Input signal from roll angle sensor too low/high	– Check the roll angle sensor. 🛠️
17	FI warning lamp (MIL) flashes 1x long, 7x short	Malfunction in lambda probe circuit	– Check the lambda probe. 🛠️
24	FI warning lamp (MIL) flashes 2x long, 4x short	Malfunction in voltage supply circuit of EFI control unit	– Check the EFI control unit voltage supply. 🛠️
25	FI warning lamp (MIL) flashes 2x long, 5x short	Malfunction in side stand switch circuit	– Check the side stand switch. 🛠️
26	FI warning lamp (MIL) flashes 2x long, 6x short	Malfunction in Hall sensor throttle valve control circuit	– Check the Hall sensor throttle valve control. 🛠️

Fault	Description	Possible cause	Measure
27	FI warning lamp (MIL) flashes 2x long, 7x short	Malfunction in voltage supply circuit of throttle valve control unit	– Check the throttle valve control unit voltage supply. 🛠️
33	FI warning lamp (MIL) flashes 3x long, 3x short	Malfunction in injection valve circuit	– Check the injection valve. 🛠️
37	FI warning lamp (MIL) flashes 3x long, 7x short	Malfunction in ignition coil circuit	– Check the ignition coil. 🛠️
41	FI warning lamp (MIL) flashes 4x long, 1x short	Fault/short-circuit in fuel pump control circuit	– Check the fuel pump control. 🛠️
45	FI warning lamp (MIL) flashes 4x long, 5x short	Malfunction or short-circuit after positive in lambda probe heating circuit	– Check the lambda probe heating. 🛠️
54	FI warning lamp (MIL) flashes 5x long, 4x short	Fault/short-circuit in secondary air valve circuit	– Check the secondary air valve. 🛠️
55	FI warning lamp (MIL) flashes 5x long, 5x short	Malfunction in throttle valve control unit circuit (internal)	– Check the throttle valve control unit. 🛠️
58	FI warning lamp (MIL) flashes 5x long, 8x short	Malfunction in release of throttle stepper in EPT mode	– Check the throttle valve control unit. 🛠️ – Check the EFI control unit. 🛠️
60	FI warning lamp (MIL) flashes 6x long	Malfunction in throttle stepper circuit	– Check the throttle stepper motor. 🛠️
68	FI warning lamp (MIL) flashes 6x long, 8x short	Connection of pressure sensor of induction manifold leaky	– Check the connection of the pressure sensor of the induction manifold. 🛠️
90	FI warning lamp (MIL) flashes 9x long	Throttle valve position not plausible	– Check the throttle valve position. 🛠️

Fault	Description	Possible cause	Measure
91	FI warning lamp (MIL) flashes 9x long, 1x short	Malfunction in CAN bus communication	– Check CAN bus communication. 🛠️
92	FI warning lamp (MIL) flashes 9x long, 2x short	Malfunction in voltage supply circuit of throttle valve control unit (internal)	– Check the throttle valve control unit. 🛠️

Cleaning motorcycle

Note

Material damage Damage and destruction of components by high-pressure cleaning equipment.

- Never clean the vehicle with high-pressure cleaning equipment or a strong water-jet. The excessive pressure can penetrate electrical components, connects, Bowden cables, and bearings, etc., and can damage or destroy these parts.



Warning

Environmental hazard Problem materials cause environmental damage.

- Dispose of oil, grease, filters, fuel, cleaning substances, brake fluid, batteries, etc. according to regulations.



Info

If you clean the motorcycle regularly, its value and appearance are maintained over a long period.
Avoid direct sunshine on the motorcycle during cleaning.

- Before you clean the motorcycle, seal the exhaust system to prevent penetration by water.
- First remove coarse dirt particles with a gentle water spray.
- Spray very dirty areas with a normal motorcycle cleaner and then clean with a paintbrush.

Motorcycle cleaner (🔧 P. 165)



Info

Use warm water containing normal motorcycle cleaner and a soft sponge.
If you have ridden the vehicle on salted roads, clean it with cold water. Warm water would reinforce the effect of the salt.

- After rinsing the motorcycle thoroughly with a soft jet of water, dry it with compressed air and a cloth.



Warning

Danger of accidents Reduced braking due to wet or dirty brakes.

- Clean or dry dirty or wet brakes by riding and braking gently.

- After cleaning, ride the vehicle a short distance until the engine warms up, and then apply the brakes.



Info

The heat produced causes water at inaccessible positions in the engine and the brakes to evaporate.

- Push back the protection covers on the handlebar instruments to allow water to evaporate.
- After the motorcycle has cooled off, oil or grease all moving parts and bearings.
- Clean the chain. (🔧 P. 64)
- Treat bare metal parts (except for brake discs and exhaust system) with anti-corrosion materials.

Cleaning and polishing materials for metal, rubber and plastic (🔧 P. 166)

- Treat all painted parts with a mild paint polish.

High-luster polish for paint (🔧 P. 166)

- To prevent electrical problems, treat electric contacts and switches with contact spray.

Contact spray (🔧 P. 166)

- Oil the ignition/steering lock.

Universal oil spray (🔧 P. 166)

Conservation for winter operation

Info

If you use the motorcycle in winter, you must expect salt on the roads. You should therefore take precautions against aggressive road salt.

If you have ridden the vehicle on salted roads, clean it with cold water. Warm water would reinforce the effect of the salt.

- Clean the motorcycle. (🔧 P. 142)
 - Treat the engine, the swingarm, and all other bare or galvanized parts (except brake discs) with a wax-based anti-corrosion substance.
-

Info

To prevent serious reduction of the braking efficiency, make sure no anti-corrosion substance gets on to the brake discs. After use on salted roads, clean the motorcycle thoroughly with cold water and dry it properly.

- Clean the chain. (🔧 P. 64)

Storage

Info

If you want to garage the motorcycle for a longer period, take the following actions.

Before storing the motorcycle, check all parts for function and wear. If service, repairs or replacements are necessary, you should do this during the storage period (less workshop overload). In this way, you can avoid long workshop waiting times at the start of the new season.

- Make sure the tank is as empty as possible so that you can fill up with fresh fuel when you put the motorcycle back into operation.
- Clean the motorcycle. (🔧 P. 142)
- Change engine oil and oil filter, clean oil screens. 🛠️ (🔧 P. 127)
- Check the antifreeze and coolant level. (🔧 P. 116)
- Checking the tire air pressure. (🔧 P. 86)
- Remove the battery. 🛠️ (🔧 P. 90)
- Recharge the battery. 🛠️ (🔧 P. 94)

Specification

Storage temperature of battery without direct sunshine.	0... 35 °C (32... 95 °F)
---	--------------------------

- The storage place should be dry and not subject to large temperature differences.

Info

KTM recommends jacking up the motorcycle.

- Jack up the rear of the motorcycle. (🔧 P. 57)
- Jack up the front of the motorcycle. (🔧 P. 56)

- Cover the motorcycle with a porous sheet or blanket.



Info

Do not use non-porous materials since they prevent humidity from escaping, thus causing corrosion.

Avoid running the engine for a short time only. Since the engine cannot warm up properly, the water vapor produced during combustion condenses and causes valves and exhaust system to rust.

Putting into operation after storage

- Take the front from the work stand. (🔧 P. 56)
- Taking rear from work stand. (🔧 P. 57)
- Recharge the battery. 🔌 (🔧 P. 94)
- Install the battery. 🔌 (🔧 P. 92)
- Set the clock. (🔧 P. 28)
- Fill up with fuel. (🔧 P. 51)
- Carry out checks before putting into operation. (🔧 P. 42)
- Make a test ride.

Design	1-cylinder 4-stroke engine, water-cooled
Displacement	654 cm ³ (39.91 cu in)
Stroke	80 mm (3.15 in)
Bore	102 mm (4.02 in)
Compression ratio	11,8:1
Control	OHC, 4 valves controlled via rocker arm, chain drive
Valve diameter, intake	40 mm (1.57 in)
Valve diameter, exhaust	34 mm (1.34 in)
Valve play, cold	0.07... 0.13 mm (0.0028... 0.0051 in)
Crankshaft bearing	2 roller bearings
Conrod bearing	Needle bearing
Piston pin bearing	Bronze bush
Pistons	Forged light alloy
Piston rings	1 L-ring, 1 tapered compression piston ring, 1 oil scraper ring
Engine lubrication	Pressure circulation lubrication with 2 rotor pumps
Primary transmission	36:79
Clutch	APTC antihopping clutch in oil-bath / hydraulically actuated
Gearbox	6-gears, claw-shifted
Transmission ratio	
1st gear	14:35
2nd gear	16:28
3rd gear	21:28
4th gear	21:23
5th gear	23:22

6th gear	23:20
Mixture preparation	Electronic fuel injection
Ignition	Contactless controlled fully electronic ignition with digital ignition adjustment, type Keihin
Generator	12 V, 224 W
Spark plug	NGK LKAR 8AI - 9
spark plug electrode gap	0.9 mm (0.035 in)
Cooling	Water cooling, permanent circulation of coolant by water pump
Starting aid	Electric starter, automatic decompressor

Capacity - engine oil

Engine oil	1.70 l (1.8 qt.)	Engine oil (SAE 10W/60) (☛ P. 163)
------------	------------------	------------------------------------

Capacity - coolant

Coolant	1.20 l (1.27 qt.)	Coolant (☛ P. 162)
		Coolant (mixed ready to use) (☛ P. 162)

TECHNICAL DATA - ENGINE TIGHTENING TORQUES

Plug, oil bore	self-tapping	9 Nm (6.6 lbf ft)	Loctite® 243™
Screw, membrane fixation	M3	2.5 Nm (1.84 lbf ft)	Loctite® 243™
Oil jet, conrod lubrication	M4	2 Nm (1.5 lbf ft)	Loctite® 243™
Hose clamp, intake flange	M4	1.5 Nm (1.11 lbf ft)	–
Screw, cover plate for oil return line	M5	6 Nm (4.4 lbf ft)	–
Screw, breather cover on valve cover	M5	3 Nm (2.2 lbf ft)	Loctite® 243™
Screw, gear sensor	M5	5 Nm (3.7 lbf ft)	Loctite® 243™
Screw, clutch spring	M5	6 Nm (4.4 lbf ft)	–
Locking screw for bearing	M5	6 Nm (4.4 lbf ft)	Loctite® 648™
Screw, oil filter cover	M5	6 Nm (4.4 lbf ft)	–
Screw, oil pump cover	M5	6 Nm (4.4 lbf ft)	Loctite® 243™
Oil jet, piston cooling	M6x0.75	4 Nm (3 lbf ft)	Loctite® 243™
Screw, locking lever	M6	10 Nm (7.4 lbf ft)	Loctite® 243™
Screw, Autodecompression	M6	3... 4 Nm (2.2... 3 lbf ft)	Loctite® 243™
Screw, axial lock of camshaft	M6	10 Nm (7.4 lbf ft)	Loctite® 243™
Screw, timing chain guide rail	M6	10 Nm (7.4 lbf ft)	Loctite® 243™
Screw generator cover	M6	10 Nm (7.4 lbf ft)	–
Screw in generator cover (chain shaft through-hole)	M6	10 Nm (7.4 lbf ft)	Loctite® 243™
Screw, ignition pulse generator	M6	10 Nm (7.4 lbf ft)	Loctite® 243™
Screw, rocker arm shaft	M6	12 Nm (8.9 lbf ft)	–
Screw, clutch cover	M6	10 Nm (7.4 lbf ft)	–
Screw, clutch slave cylinder	M6x20	10 Nm (7.4 lbf ft)	Loctite® 243™
Screw, clutch slave cylinder	M6x35	10 Nm (7.4 lbf ft)	–

TECHNICAL DATA - ENGINE TIGHTENING TORQUES

Screw, engine housing	M6	10 Nm (7.4 lbf ft)	–
Screw, shift drum locating	M6	10 Nm (7.4 lbf ft)	Loctite® 243™
Screw, shift lever	M6	10 Nm (7.4 lbf ft)	Loctite® 222
Screw, timing chain tensioning rail	M6	10 Nm (7.4 lbf ft)	Loctite® 243™
Screw, starter motor	M6	10 Nm (7.4 lbf ft)	Loctite® 243™
Screw, stator bracket	M6	10 Nm (7.4 lbf ft)	Loctite® 243™
Screw, thermostat housing	M6	10 Nm (7.4 lbf ft)	Loctite® 243™
Screw, valve cover	M6	10 Nm (7.4 lbf ft)	–
Screw, water pump cover	M6	10 Nm (7.4 lbf ft)	–
Screw, water pump wheel	M6	10 Nm (7.4 lbf ft)	Loctite® 243™
Screw, cylinder	M6	10 Nm (7.4 lbf ft)	Loctite® 243™
Screw, cylinder head	M6	10 Nm (7.4 lbf ft)	Loctite® 243™
Plug, vacuum connection	M6	10 Nm (7.4 lbf ft)	Loctite® 243™
Stud, exhaust flange	M8	10 Nm (7.4 lbf ft)	Loctite® 243™
Plug, crankshaft location	M8	20 Nm (14.8 lbf ft)	–
Screw, unlocking of timing chain tensioner	M10x1	10 Nm (7.4 lbf ft)	–
Plug, drain hole of water pump	M10x1	15 Nm (11.1 lbf ft)	–
Plug, oil bore for oil radiator	M10x1	15 Nm (11.1 lbf ft)	–
Plug, oil bore	M10x1	15 Nm (11.1 lbf ft)	Loctite® 243™

Screw, cylinder head	M10	Tightening sequence: Tighten diagonally, beginning with the rear screw on the chain shaft. Step 1 15 Nm (11.1 lbf ft) Step 2 30 Nm (22.1 lbf ft) Step 3 45 Nm (33.2 lbf ft) Step 4 60 Nm (44.3 lbf ft)	Engine oil (any)
Spark plug	M12x1,25	17 Nm (12.5 lbf ft)	–
Coolant temperature sensor on cylinder head	M12x1.5	12 Nm (8.9 lbf ft)	–
Oil drain plug with magnet	M12x1,5	20 Nm (14.8 lbf ft)	–
Oil pressure regulator valve plug	M12x1.5	20 Nm (14.8 lbf ft)	–
Plug, oil bore	M14x1,5	15 Nm (11.1 lbf ft)	Loctite® 243™
Engine case stud	M16x1.5	25 Nm (18.4 lbf ft)	Loctite® 243™
Ignition rotor nut	M18x1,5	100 Nm (73.8 lbf ft)	–
Nut, engine sprocket	M20x1,5	60 Nm (44.3 lbf ft)	Loctite® 243™
Nut, inner clutch hub	M20x1,5	100 Nm (73.8 lbf ft)	Loctite® 243™
Nut, primary gear	M20LHx1,5	100 Nm (73.8 lbf ft)	Loctite® 243™
Plug, oil screen	M20x1,5	15 Nm (11.1 lbf ft)	–
Plug, timing chain tensioner	M20x1,5	25 Nm (18.4 lbf ft)	–
Screw in generator cover	M24x1.5	8 Nm (5.9 lbf ft)	–
Plug, oil thermostat	M24x1,5	15 Nm (11.1 lbf ft)	–

Frame	Lattice frame made of chrome molybdenum steel tubing, powder-coated
Fork	WP Suspension Up Side Down 4860 ROMA
Shock absorber	WP Suspension 4618 with Pro-Lever deflector
Suspension travel	
front	140 mm (5.51 in)
Rear	140 mm (5.51 in)
Brake system	
front	Disc brake with radially screwed four-piston brake caliper, floating brake disc
Rear	Disc brake with single-piston brake caliper, floating
Diameter of brake discs	
front	320 mm (12.6 in)
Rear	240 mm (9.45 in)
Wear limit of brake discs	
front	3.6 mm (0.142 in)
Rear	4.5 mm (0.177 in)
Tire air pressure, road, solo	
front	2.0 bar (29 psi)
Rear	2.0 bar (29 psi)
Tire air pressure with passenger / fully loaded	
front	2.0 bar (29 psi)
Rear	2.2 bar (32 psi)
Rear wheel gearing	16:40
Chain	5/8 x 1/4" X-ring

Steering head angle	63.5°
Wheelbase	1,472±15 mm (57.95±0.59 in)
Seat height unloaded	865 mm (34.06 in)
Ground clearance unloaded	155 mm (6.1 in)
Weight without fuel	148.5 kg (327.4 lb.)
Maximum permissible front axle load	150 kg (331 lb.)
Maximum permissible rear axle load	200 kg (441 lb.)
Maximum permissible overall weight	350 kg (772 lb.)

Battery	YTZ10S	Battery voltage: 12 V Nominal capacity: 8.6 Ah maintenance-free
Fuse	58011109130	30 A
Fuse	75011088015	15 A
Fuse	75011088010	10 A

Lighting equipment

Low beam/high beam	HB3/P20d	12 V 60 W
Parking light	W2,1x9,5d	12 V 5 W
Instrument lights and indicator lamps	LED	
Flasher light	BAU15s	12 V 10 W
Brake / tail light	LED	

Licence plate lamp	W2,1x9,5d	12 V 5 W
--------------------	-----------	-------------

Validity	Front tire	Rear tire
	120/70 R 17 58 H TL Dunlop Sportmax GPR Alpha 10	160/60 R 17 69 H TL Dunlop Sportmax GPR Alpha 10

For further information, see:
<http://www.ktm.com>

Capacity - fuel

Fuel tank content	13.5 l (3.57 US gal)	Super unleaded (ROZ 95 / RON 95 / PON 91) (☛ P. 162)
Fuel reserve	2.5 l (2.6 qt.)	

Fork part number	14.18.7D.09
Fork	WP Suspension Up Side Down 4860 ROMA
Compression damping	
Comfort	20 clicks
Standard	15 clicks
Sport	10 clicks
full payload	10 clicks
Rebound damping	
Comfort	20 clicks
Standard	15 clicks
Sport	10 clicks
full payload	10 clicks
Spring length with preload spacer(s)	352 mm (13.86 in)
Spring rate	
Weight of rider: 75... 85 kg (165... 187 lb.)	7.5 N/mm (42.8 lb/in)
Air chamber length	110 \pm 20 mm (4.33 \pm 0.79 in)
Fork length	850 mm (33.46 in)
Fork oil (☛ P. 163)	SAE 5

TECHNICAL DATA - SHOCK ABSORBER

Shock absorber part number	15.18.7D.09
Shock absorber	WP Suspension 4618 with Pro-Lever deflector
Compression damping, high-speed	
Comfort	2 turns
Standard	1.5 turns
Sport	1 turn
full payload	1 turn
Compression damping, low-speed	
Comfort	20 clicks
Standard	15 clicks
Sport	10 clicks
full payload	10 clicks
Rebound damping	
Comfort	20 clicks
Standard	15 clicks
Sport	10 clicks
full payload	10 clicks
Spring preload	
Comfort	12 mm (0.47 in)
Standard	12 mm (0.47 in)
Sport	12 mm (0.47 in)
full payload	15 mm (0.59 in)
Spring rate	
Weight of rider: 75... 85 kg (165... 187 lb.)	70 N/mm (400 lb/in)

TECHNICAL DATA - SHOCK ABSORBER

Weight of rider: 85... 95 kg (187... 209 lb.)	75 N/mm (428 lb/in)
Spring length	185 mm (7.28 in)
Gas pressure	10 bar (145 psi)
Static sag	25 mm (0.98 in)
Riding sag	60... 65 mm (2.36... 2.56 in)
Fitted length	376 mm (14.8 in)

TECHNICAL DATA - CHASSIS TIGHTENING TORQUES

Screw, combination instrument		1 Nm (0.7 lbf ft)	–
Screw, combination instrument holder		1 Nm (0.7 lbf ft)	–
Screw, side stand switch	M4	2 Nm (1.5 lbf ft)	Loctite® 243™
Remaining screws, chassis	M5	4 Nm (3 lbf ft)	–
Screw, pressure regulator	M5	4 Nm (3 lbf ft)	–
Screw, footbrake pedal foothold	M5	6 Nm (4.4 lbf ft)	Loctite® 243™
Screw, plastic clamp of brake line on fork leg	M5	2 Nm (1.5 lbf ft)	–
Screw, fuel pump	M5	4 Nm (3 lbf ft)	–
Screw, fuel level indicator	M5	3 Nm (2.2 lbf ft)	–
Screw, side cover	M5	2 Nm (1.5 lbf ft)	–
Screw, seat lock	M5	3 Nm (2.2 lbf ft)	Loctite® 222
Screw, starter cable on starter	M5	3 Nm (2.2 lbf ft)	–
Remaining nuts, chassis	M6	15 Nm (11.1 lbf ft)	–
Remaining screws on fuel tank	M6	6 Nm (4.4 lbf ft)	–
Remaining screws, chassis	M6	10 Nm (7.4 lbf ft)	–
Screw, brake fluid reservoir of rear brake	M6	5 Nm (3.7 lbf ft)	–
Screw, battery holder	M6	3 Nm (2.2 lbf ft)	–
Screw, bug spoiler	M6	7 Nm (5.2 lbf ft)	–
Screw, footbrake cylinder	M6	10 Nm (7.4 lbf ft)	Loctite® 243™
Screw, horn	M6	6 Nm (4.4 lbf ft)	Loctite® 243™
Screw, license plate holder	M6	8 Nm (5.9 lbf ft)	–
Screw, ball joint of push rod on footbrake cylinder	M6	10 Nm (7.4 lbf ft)	Loctite® 243™
Screw, lower radiator bracket	M6	5 Nm (3.7 lbf ft)	–

TECHNICAL DATA - CHASSIS TIGHTENING TORQUES

Screw, fuel tap	M6	Tightening sequence: tighten in parallel 6 Nm (4.4 lbf ft)	–
Screw, magnetic holder on side stand	M6	10 Nm (7.4 lbf ft)	Loctite® 243™
Screw, voltage regulator/rectifier	M6	8 Nm (5.9 lbf ft)	–
Screw, SLS valve	M6	6 Nm (4.4 lbf ft)	–
Screw, headlight mask	M6	5 Nm (3.7 lbf ft)	–
Screw, side stand bracket	M6	10 Nm (7.4 lbf ft)	Loctite® 243™
Screw, control unit holder	M6	3 Nm (2.2 lbf ft)	–
Nut, rear sprocket screw	M8	35 Nm (25.8 lbf ft)	Loctite® 243™
Nut, manifold on cylinder head	M8	25 Nm (18.4 lbf ft)	Copper paste
Remaining nuts, chassis	M8	30 Nm (22.1 lbf ft)	–
Remaining screws, chassis	M8	25 Nm (18.4 lbf ft)	–
Screw, rear brake disc	M8	30 Nm (22.1 lbf ft)	Loctite® 243™
Screw, front brake disc	M8	30 Nm (22.1 lbf ft)	Loctite® 243™
Screw, main silencer fixation	M8	25 Nm (18.4 lbf ft)	–
Screw, spring holder on side stand bracket	M8	15 Nm (11.1 lbf ft)	Loctite® 243™
Screw, rear footrest bracket	M8	25 Nm (18.4 lbf ft)	Loctite® 243™
Screw, top triple clamp	M8	12 Nm (8.9 lbf ft)	–
Screw, bottom triple clamp	M8	15 Nm (11.1 lbf ft)	–
Screw, fork stub	M8	15 Nm (11.1 lbf ft)	–
Screw, steering stem	M8	20 Nm (14.8 lbf ft)	–
Screw, handrail	M8	6 Nm (4.4 lbf ft)	–
Screw, fuel tank bracket	M8	15 Nm (11.1 lbf ft)	–

TECHNICAL DATA - CHASSIS TIGHTENING TORQUES

Screw, manifold on main silencer	M8	25 Nm (18.4 lbf ft)	Copper paste
Screw, handlebar clamp	M8	20 Nm (14.8 lbf ft)	–
Screw, upper subframe	M8	35 Nm (25.8 lbf ft)	Loctite® 243™
Screw, side stand bracket	M8	25 Nm (18.4 lbf ft)	Loctite® 243™
Screw, linkage bracket, front engine bracket	M8	25 Nm (18.4 lbf ft)	Loctite® 243™
Screw, ignition lock	M8		Loctite® 243™
Screw, front brake caliper	M10x1.25	45 Nm (33.2 lbf ft)	Loctite® 243™
Screw, lower subframe	M10x1.25	45 Nm (33.2 lbf ft)	Loctite® 243™
Engine carrying screw	M10	45 Nm (33.2 lbf ft)	Loctite® 243™
Remaining nuts, chassis	M10	50 Nm (36.9 lbf ft)	–
Remaining screws, chassis	M10	45 Nm (33.2 lbf ft)	–
Screw, top shock absorber	M10	45 Nm (33.2 lbf ft)	Loctite® 243™
Screw, bottom shock absorber	M10	45 Nm (33.2 lbf ft)	Loctite® 243™
Screw, handlebar support	M10	20 Nm (14.8 lbf ft)	–
Screw, side stand	M10	35 Nm (25.8 lbf ft)	Loctite® 243™
Lambda probe	M12x1.25	24.5 Nm (18.07 lbf ft)	–
Nut, frame to linkage lever	M14x1.5	100 Nm (73.8 lbf ft)	–
Nut, linkage lever to rocker arm	M14x1.5	100 Nm (73.8 lbf ft)	–
Nut, linkage lever on swingarm	M14x1.5	100 Nm (73.8 lbf ft)	–
Nut, swingarm pivot	M16x1.5	100 Nm (73.8 lbf ft)	–
Screw, steering head	M20x1.5	12 Nm (8.9 lbf ft)	–
Adjusting ring of swingarm bearing	M24x1.5	25 Nm (18.4 lbf ft)	–
Screw, front wheel spindle	M24x1.5	40 Nm (29.5 lbf ft)	–

TECHNICAL DATA - CHASSIS TIGHTENING TORQUES

Nut, rear wheel spindle	M25x1.5	90 Nm (66.4 lbf ft)	-
-------------------------	---------	---------------------	---

Super unleaded (ROZ 95 / RON 95 / PON 91)

according to

- DIN EN 228 (ROZ 95 / RON 95 / PON 91)

Brake fluid DOT 5.1

according to

- DOT

Specification

- Use only brake fluid that complies with the specified standards (see specifications on the container) and that possesses the corresponding properties. KTM recommends **Motorex®** products.

Supplier

Motorex®

- **Brake Fluid DOT 5.1**

Coolant

Specification

- Use only suitable coolant (even in countries with high temperatures). Using inferior antifreeze can result in corrosion and foaming. KTM recommends **Motorex®** products.

Mixture ratio

Antifreeze: -25... -45 °C (-13... -49 °F)	50 % Anti-corrosion/antifreeze 50 % distilled water
---	--

Coolant (mixed ready to use)

Antifreeze	-40 °C (-40 °F)
------------	-----------------

Supplier

Motorex®

- **Anti Freeze**

Hydraulic fluid (15)

according to

- ISO VG (15)

Specification

- Use only hydraulic fluid that complies with the specified standards (see specifications on the container) and that possesses the corresponding properties. KTM recommends **Motorex®** products.

Supplier

Motorex®

- **Hydraulic Fluid 75**

Engine oil (SAE 10W/60)

according to

- JASO T903 MA (☛ P. 167)
- SAE (☛ P. 167) (SAE 10W/60)

Specification

- Use only engine oils that comply with the specified standards (see specifications on the container) and that possess the corresponding properties. KTM recommends **Motorex®** products.

Synthetic engine oil

Supplier

Motorex®

- **Cross Power 4T**

Fork oil (SAE 5)

according to

- SAE (☛ P. 167) (SAE 5)

Specification

- Use only oils that comply with the specified standards (see specifications on the container) and that possesses the corresponding properties. KTM recommends **Motorex®** products.

Supplier

Motorex®

- **Racing Fork Oil**

Chain cleaner

Specification

- KTM recommends **Motorex®** products.

Supplier

Motorex®

- **Motorex® Chain Clean 611**

Onroad chain spray

Specification

- KTM recommends **Motorex®** products.

Supplier

Motorex®

- **Motorex® Chain Lube 622 Strong**

Long-life grease

Specification

- KTM recommends **Motorex®** products.

Supplier

Motorex®

- **Motorex® Long Therm 2000**

Motorcycle cleaner

Specification

- KTM recommends **Motorex®** products.

Supplier

Motorex®

- **Motorex® Moto Clean 900**

Cleaning and polishing materials for metal, rubber and plastic

Specification

- KTM recommends **Motorex®** products.

Supplier

Motorex®

- **Motorex®** Protect & Shine **645**

High-luster polish for paint

Specification

- KTM recommends **Motorex®** products.

Supplier

Motorex®

- **Motorex®** Moto Polish

Contact spray

Specification

- KTM recommends **Motorex®** products.

Supplier

Motorex®

- **Motorex®** Accu Contact

Universal oil spray

Specification

- KTM recommends **Motorex®** products.

Supplier

Motorex®

- **Motorex®** Joker 440 Universal

JASO T903 MA

Different technical development directions required a new specification for 4-stroke motorcycles – the JASO T903 MA Standard. Earlier, engine oils from the automobile industry were used for 4-stroke motorcycles because there was no separate motorcycle specification. Whereas long service intervals are demanded for automobile engines, high performance at high engine speeds are in the foreground for motorcycle engines. With most motorcycles, the gearbox and the clutch are lubricated with the oil as the engine. The JASO MA Standard meets these special requirements.

SAE

The SAE viscosity classes were defined by the Society of Automotive Engineers and are used for classifying oils according to their viscosity. The viscosity describes only one property of oil and says nothing about quality.

A

Antifreeze

checking116

B

Baggage40

Battery

installing92

recharging94

removing90

Brake discs

checking70

Brake fluid

of rear brake, adding76

topping up brake fluid of front brake72

Brake fluid level

checking the brake fluid level of front brake71

of rear brake, checking75

Brake linings **73**

Checking the front brake brake fluid level74

of rear brake, checking78

Brakes48

Braking48

C

Chain

checking dirt64

checking wear69

cleaning64

Chain tension

adjusting66

checking65

Chassis number16

Cleaning142-143

Clutch

checking/correcting fluid level124

Clutch lever **19**

adjusting basic position123

Combination instrument **23**

Coolant temperature indicator31

Display26

Display ODO29

DisplayTRIP F31

Function buttons24

Indicator lights25

Setting kilometers or miles27

Setting the clock28

Setting/resetting TRIP 1 display29

Setting/resetting TRIP 2 display30

Speed display27

Tachometer24

Time28

Conservation for winter operation144

Coolant

draining120

Coolant level	
checking	116, 119
Cooling system	116
filling/bleeding	121
D	
Display	26
E	
Electric starter button	23
Emergency OFF switch	22
Engine	
running in	39
Engine characteristics	
adjusting	99
Engine number	17
Engine oil	
changing	127
draining	127
refilling	133
topping up	134
Engine oil level	
checking	126
Environment	8
F	
Filler cap	
closing	32
opening	32
Filling up	
Fuel	51
Flasher bulb	
changing	109
Flasher switch	21
Flashing code	139-141
Foot brake pedal	37
checking free play	75
Fork	58
Adjusting compression damping	58
Adjusting rebound	59
Bleeding fork legs	63
Fork part number	17
Front wheel	
fitting	80
removing	78
Fuel tank	
positioning	89
reinstalling	88
Fuel taps	33
Fuel, oils, etc.	7
Fuse	
of individual power consumer, changing	97

H

Hand brake lever	19
adjusting basic position	71
Handlebar angle	
adjusting	126
Handrails	33
Headlight adjustment	
adjusting the high beam	114
adjusting the low beam	112
checking the high beam	111
checking the low beam	110
Headlight flasher switch	20
Headlight mask with headlight	
installing	103
removing	101
High beam bulb	
changing	106
Horn	21

I

Ignition lock	22
Indicator lights	25

K

Key number	16
-------------------------	----

L

Light switch	20
---------------------------	----

Loading the vehicle	40
----------------------------------	----

Low beam bulb	
changing	104

M

Main fuse	
changing	96

Maintenance	7
--------------------------	---

Motorcycle	
cleaning	142
jacking up front	56
jacking up rear	57
taking front from work stand	56
taking rear from work stand	57

O

Oil filter	
changing	127
fitting	131
removing	129

Oil screen	
cleaning	127

Oil screens	
cleaning	131

OWNER'S MANUAL	34
Basics	9

P

Parking	49
----------------------	----

Parking light bulb	
changing	108
Passenger footrests	35
Play in gas Bowden cable	
adjusting	125
checking	124
Putting into operation	
Advice on first use	38
after storage	146
Checks before putting into operation	42
R	
Rear hub rubber dampers	
checking	84
Rear sprocket / engine sprocket	
checking for wear	68
Rear wheel	
fitting	82
removing	81
Riding	45
Starting up	45
S	
Seat	
mounting	87
removing	87
Seat lock	34
Shift lever	36

Shifting	45
Shock absorber	58
adjusting rebound damping	62
compression damping, general	60
compression damping, high-speed, adjusting	61
compression damping, low-speed, adjusting	60
Shock absorber part number	18
Side stand	37
Spare parts, accessories	8
Starting	43
Steering lock	22
Stopping	49
Storage	145
T	
Tachometer	24
Technical data	
Chassis	152-154
Chassis tightening torques	158-161
Engine	147-148
Engine tightening torques	149-151
Fork	155
Shock absorber	156-157
Tire air pressure	
checking	86
Tire condition	
checking	85
Tool set	35

Transport	8
Troubleshooting	136-138
Type label	16

V

View of vehicle

front left	12
rear right side	14

W

Warranty	7
----------------	---



3211248en



12/2007 Photo Mitterbauer



KTM-Sportmotorcycle AG
5230 Mattighofen/Austria
<http://www.ktm.com>