

SERVICE

Modell 400/620 LC4 EGS '96 (m Batt)

Kabelstrangnummer
vorne 583 11 475 100
hinten 583 11 476 000

Land
A, CH

Datum, Name
16 10 95 EK

Zeichnungsnr
41
4656MBS-

Änderungsstand

Kabelstrangbez
vo 4T E-GS 95
hi CEV 358 m Bl

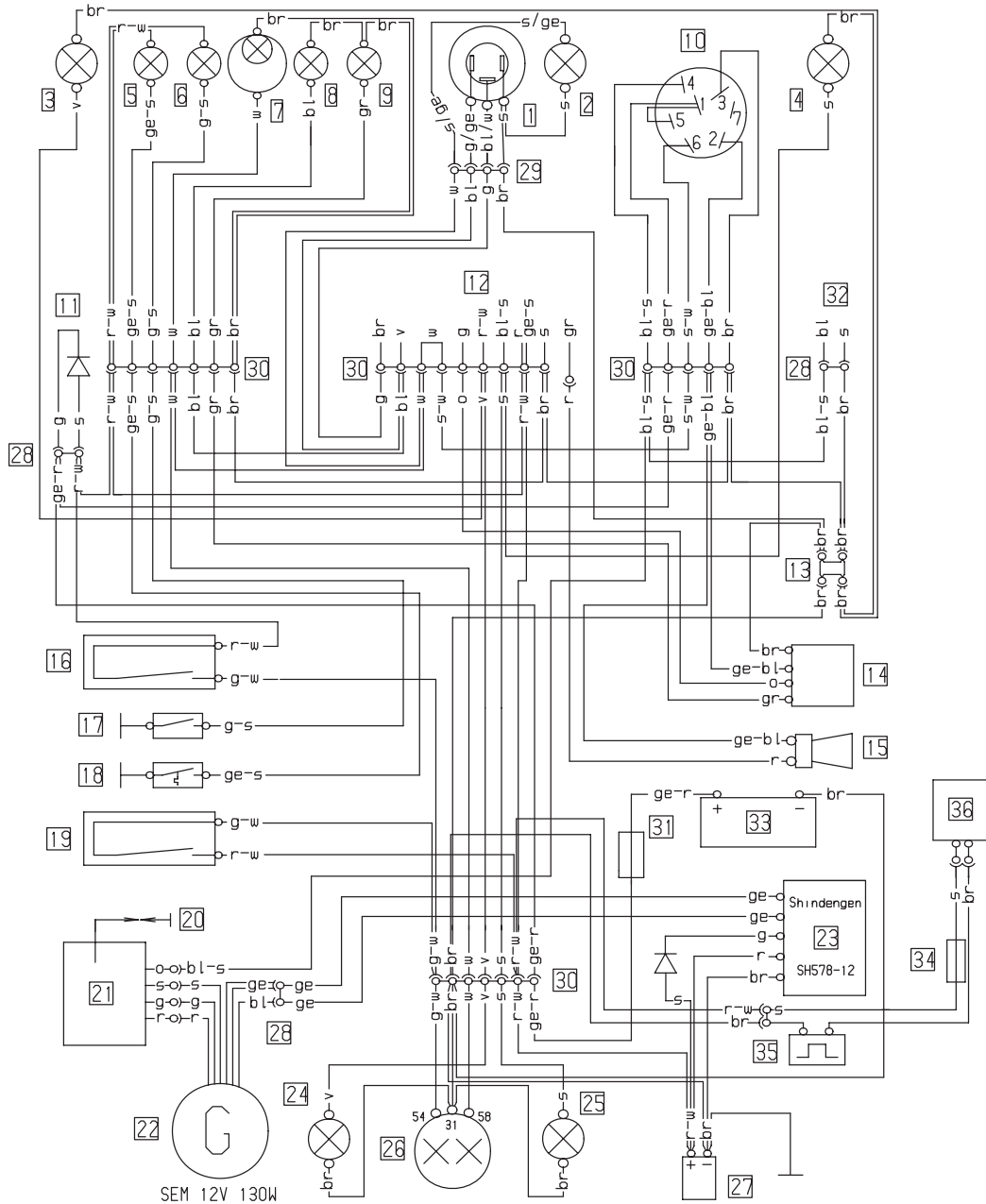

Deutsch	Englisch	Italienisch	Französisch
1 Scheinwerfer	1 headlight	1 faro	1 phare
2 Standlicht	2 parking light	2 luce di posizione	2 feu de position
3 Blinker li vo	3 blinker left front	3 lampegg ant sn	3 clignoteur av gauche
4 Blinker re vo	4 blinker right front	4 lampegg ant dx	4 clignoteur av droit
5 Temperaturkontrolle	5 temperature control	5 controllo temperatura	5 témoin d temperature
6 Leerlaufanzeige	6 neutral	6 indicat marcia folle	6 ind de point mort
7 Tachobeleuchtung	7 tachometer light	7 luce di tachimetro	7 éclair comp vitesse
8 Fernlichtkontrolle	8 high beam control	8 spia abbagliante	8 témoin de feu route
9 Blinkerkontrolle	9 blink control	9 spia lampeggiatori	9 témoin de clignoteur
10 Zündschloß	10 ignition switch	10 int accensione	10 contact d'allum
11 Diode	11 diode	11 diodo	11 diode
12 zum Kombischalter	12 to combinat switch	12 multicomando	12 commutateur
13 Masseanschluß	13 ground connection	13 collegam a massa	13 masse
14 Blinkgeber	14 blink signal system	14 trasmett di lampeg	14 centrale clignot
15 Horn	15 horn	15 clacson	15 klaxon
16 Bremslichtsch vo	16 stoplight switch f	16 int luce arresto ant	16 cont de stop av
17 Leerlaufschalter	17 neutral switch	17 interr luce folle	17 contact de pt mort
18 Temp-schalter	18 temperature switch	17 int temperatura	18 sonde de temp
19 Bremslichtsch hi	19 stoplight switch r	19 int luce arresto pos	19 cont de stop der
20 Zündkerze	20 spark plug	20 candela	20 bougie
21 Zündspule	21 ignition coil	21 bobina d'accens	21 bobine d'allumage
22 Generator	22 generator	22 dinamo	22 generateur
23 Spannungsregler	23 voltage regulator	23 regol di tens	23 regulateur
24 Blinker li hi	24 blinker left rear	24 lampegg post sn	24 clign arr gauche
25 Blinker re hi	25 blinker right rear	25 lampegg post dx	25 clign arr droit
26 Brems-Schlußlicht	26 rear-stoplight	26 fanal post di freno	26 feu arr et de stop
27 Kondensator	27 capacitor	27 condensatore	27 condensateur
28 2-pol Stecker	28 multip cont plug (2)	28 connettore a 2 poli	28 connect multiple (2)
29 4-pol Stecker	29 multip cont plug (4)	29 connettore a 4 poli	29 connect multiple (4)
30 9-pol Stecker	30 multip cont plug (9)	30 connettore a 9 poli	30 connect multiple (9)
31 Stecksicherung 10A	31 fuse 10A	31 fusibile 10A	31 fusible 10A
32 Kurzschlußschalter	32 short circuit switch	32 com corto circuito	32 bouton de masse
33 Batterie 1 2Ah	33 battery 1 2Ah	33 batteria 1 2Ah	33 batterie 1 2Ah
34 Stecksicherung 5A	34 fuse 5A	34 fusibile 5A	34 fusible 5A
35 Thermo-schalter	35 temperature switch	35 termointerruttore	35 sonde de temp
36 Ventilator	36 fan	36 ventilatore	36 ventilateur

bl	blau	bl	blue	bl	blu	bl	bleu
br	braun	br	brown	br	marrone	br	brun
ge	gelb	ge	yellow	ge	giallo	ge	jaune
gr	grau	gr	grey	gr	grigio	gr	gris
g	grün	g	green	g	verde	g	vert
o	orange	o	orange	o	arancione	o	orange
r	rot	r	red	r	rosso	r	rouge
s	schwarz	s	black	s	nero	s	noir
v	violett	v	violet	v	violetto	v	violet
w	weiß	w	white	w	bianco	w	blanc

Kontaktbelegung Kurzschlußschalter (Typ CEV 6302)

EN		s	bl
CT			
W			
E			
OFF			

Kontaktbelegung Zündschloß (Typ CEV 7-pol)

	1	2	3	4	5	6	7
PARK							
AUS							
EIN							
EIN							

Kontaktbelegung Kombischalter (Typ CEV 100826000)

	s	br	v	r-w	s-bl	g	gr	r/ge
TURN L								
TURN R								
LIGHTS								
H LO								
H HI								
HORN								
PASSING								

SERVICE

Modell 400/620 LC4 EGS '96 (o Batt)

Kabelstrangnummer
vorne 583 11 475 100
hinten 583 11 476 000

Land
BRD, DIV,

Datum, Name
16 10 95 EK

Zeichnungsnr
42
46SG0BS-

Änderungsstand

Kabelstrangbez
vo 4T E-GS 95
hi CEV 358 m Bl

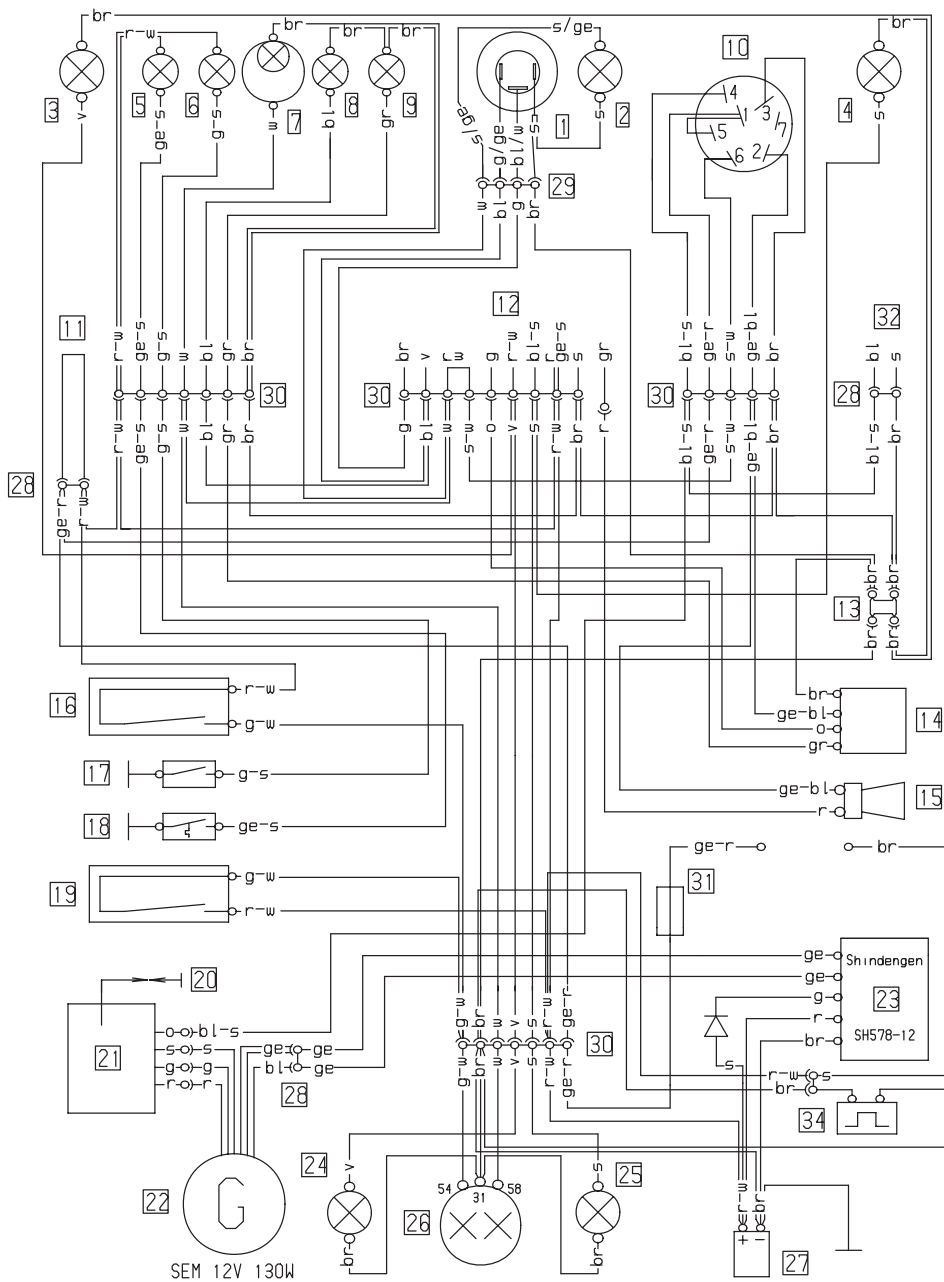

Deutsch	Englisch	Italienisch	Französisch	Spanisch
1 Scheinwerfer	1 headlight	1 faro	1 phare	1 fono
2 Standlicht	2 parking light	2 luce di posizione	2 feu de position	2 luz de posicion
3 Blinker li vo	3 blinker left front	3 lampegg ant sn	3 clignoteur av gauche	3 interm izquierdo delant
4 Blinker re vo	4 blinker right front	4 lampegg ant dx	4 clignoteur av droit	4 interm derecho delantero
5 Temperaturkontrolle	5 temperature control	5 controllo temperat	5 temoin d temperature	5 control temperatura
6 Leerlaufanzeige	6 neutral	6 indicat marcia folle	6 ind de point mort	6 indicador punto nuerto
7 Tachobeleuchtung	7 tachometer light	7 luce di tachimetro	7 eclair comp vitesse	7 luz tacometro
8 Fernlichtkontrolle	8 high beam control	8 spia abbagliante	8 temoin de feu route	8 lamp aviso luces largas
9 Blinkerkontrolle	9 blink control	9 spia lampeggiatori	9 temoin de clignoteur	9 lampara aviso intermit
10 Zündschloß	10 ignition switch	10 int accensione	10 contact d'allum	10 llave de contacto
11 Kabelbrücke	11 wire connection	11 cablaggio	11 raccord de cable	11 conector
12 zum Kombischalter	12 to combinat switch	12 multicomando	12 commutateur	12 interruptor combinado
13 Masseanschluß	13 ground connection	13 collegam a massa	13 masse	13 conector a masa
14 Blinkgeber	14 transmit system	14 trasmett di lampeg	14 centrale clignot	14 conjunto del intermit
15 Horn	15 horn	15 clacson	15 klaxon	15 claxon
16 Bremslichtsch vo	16 stoplight switch f	16 int luce arresto ant	16 cont de stop av	16 interr luz de freno del
17 Leerlaufschalter	17 neutral switch	17 interr luce folle	17 sonde de marche	17 interruptor punto muerto
18 Temp -schalter	18 temperature switch	18 int temperatura	18 arr de temp	18 interruptor temperatura
19 Bremslichtsch hi	19 stoplight switch r	19 int luce arresto post	19 cont de stop	19 interr luz de freno tras
20 Zündkerze	20 spark plug	20 candela	20 bougie	20 bujia
21 Zündspule	21 ignition coil	21 bobina d'accens	21 bobine d'allumage	21 bobina de encendido
22 Generator	22 generator	22 dinamo	22 generateur	22 generador
23 Spannungsregler	23 voltage regulator	23 regol di tens	23 regulateur	23 regulador de tension
24 Blinker li hi	24 blinker left rear	24 lampegg post sn	24 clign arr gauche	24 interm izquierdo trasero
25 Blinker re hi	25 blinker right rear	25 lampegg post dx	25 clign arr droit	25 interm derecho trasero
26 Brems-Schlußlicht	26 rear-stoplight	26 fanal post di freno	26 feu arr et de stop	26 luz de freno trasera
27 Kondensator	27 capacitor	27 condensatore	27 condensateur	27 condensador
28 2-pol Stecker	28 multip cont plug (2)	28 connettore a 2 poli	28 connecteur multiple (2)	28 conector multiple (2)
29 4-pol Stecker	29 multip cont plug (4)	29 connettore a 4 poli	29 connecteur multiple (4)	29 conector multiple (4)
30 9-pol Stecker	30 multip cont plug (9)	30 connettore a 9 poli	30 connecteur multiple (9)	30 conector multiple (9)
31 Stecksicherung 10A	31 fuse 10A	31 fusibile 10A	31 fusible 10A	31 fusible principal 10A
32 Kurzschlußschalter	32 short circuit switch	32 com corto circuito	32 bouton de masse	32 interruptor a masa
33 Stecksicherung 5A	33 fuse 5A	33 fusibile 5A	33 fusible 5A	33 fusible 5A
34 Thermoschalter	34 temperature switch	34 interruttore di temp	34 sonde de temp	34 interruptor temperatura
35 Ventilator	35 fan	35 termointerruttore	35 ventilateur	35 ventilador electrico

bl	blau	bl	bleu	bl	azul
br	braun	br	marrone	br	marron
ge	gelb	ge	giallo	ge	jaune
gr	grau	gr	grigio	gr	gris
g	grün	g	verde	g	verde
o	orange	o	arancione	o	orange
r	rot	r	rosso	r	rouge
s	schwarz	s	nero	s	noir
v	violett	v	violetto	v	violet
w	weiß	w	bianco	w	blanc

Kontaktbelegung - Kombischalter (Typ CEV 100826000)

	s	br	v	r-w	s-bl	g	gr	r/ge-s
TURN L								
TURN R								
LIGHTS								
H LO								
H HI								
HORN								
PASSING								

Kontaktbelegung Zündschloß (Typ CEV 7-pol)

	1	2	3	4	5	6	7
PARK							
AUS							
EIN							
EIN							

Kontaktbelegung Kurzschlußschalter (Typ CEV 6302)

	s	bl
ENGINE RUN		
ENGINE OFF		

SERVICE

Modell

400/620 E-GS '96

Kabelstrangnummer

vorne 583 11 475 200
hinten 583 11 476 000

Land

AUSTRALIEN

Datum, Name

19 10 95 KE

Zeichnungsnr

46S60BSA

Änderungsstand

Kabelstrangbez

vo EGS Austr
hi 4-T EGS

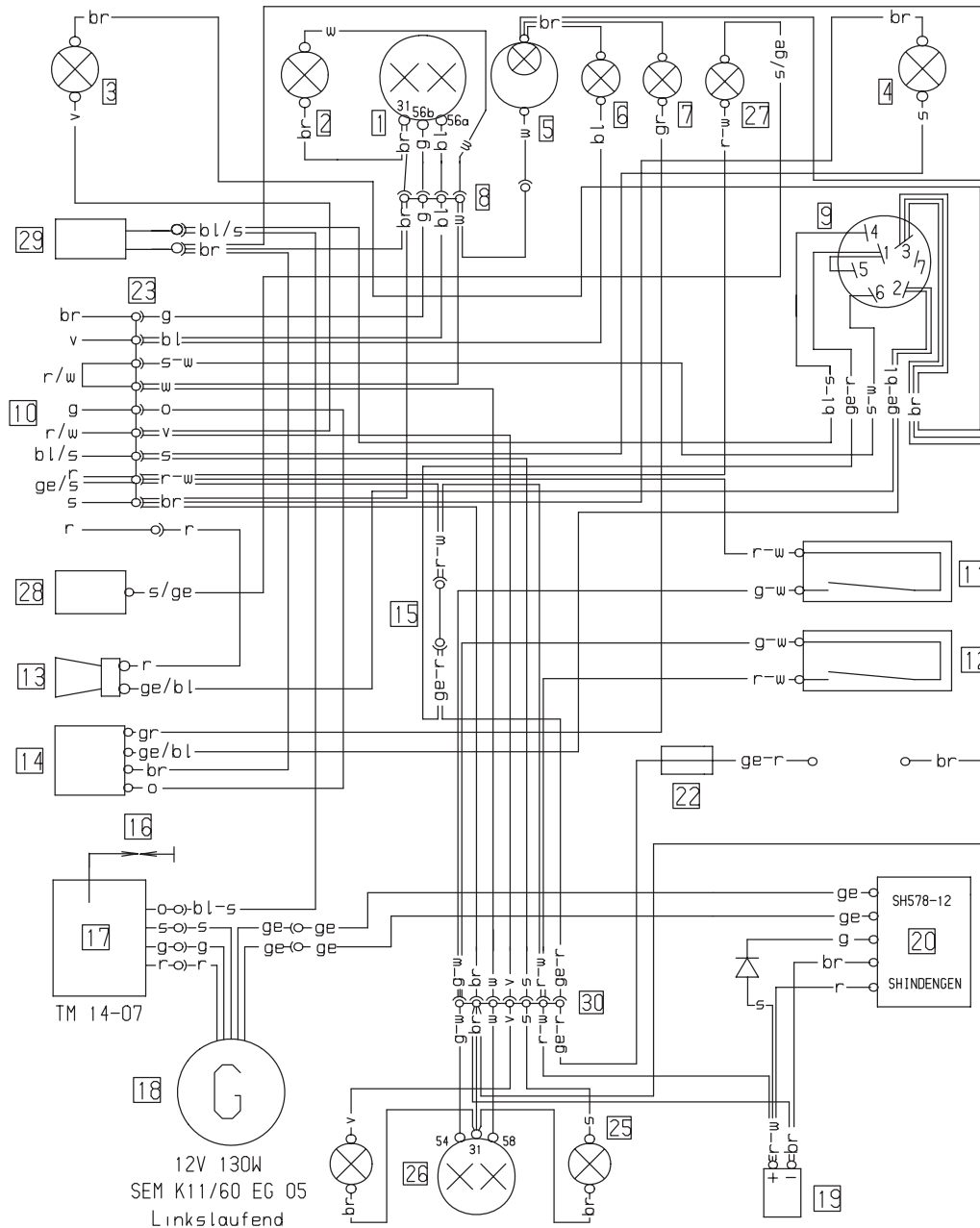

Deutsch	Englisch	Italienisch	Französisch
1 Scheinwerfer	1 headlight	1 fano	1 phare
2 Standlicht	2 parking light	2 luce di posizione	2 feu de position
3 Blinker li vo	3 blinker left front	3 lampegg ant sn	3 clignoteur av gauche
4 Blinker re vo	4 blinker right front	4 lampegg ant dx	4 clignoteur av droit
5 Tachobeleuchtung	5 tachometer light	5 luce di tachmetro	5 éclair comp vitesse
6 Fernlichtkontrolle	6 high beam control	6 spia abbagliante	6 témoin feu route
7 Blinkerkontrolle	7 blink control	7 spia lampeggiatori	7 témoin de clignoteur
8 4-pol Stecker	8 multip cont plug (4)	8 connettore a 4 poli	8 connect multiple (4)
9 Zündschloß	9 ignition switch	9 int accensione	9 contact d'allum
10 zum Kombischalter	10 to combinat switch	10 multicomando	10 commodo
11 Bremslichtsch vo	11 stoptlight switch f	11 int luce arresto ant	11 contact de stop av
12 Bremslichtsch hi	12 stoptlight switch r	12 int luce arresto post	12 contact de stop
13 Horn	13 horn	13 clacson	13 klaxon
14 Blinkgeber	14 blink signal system	14 centrale di lampeg	14 centrale clignot
15 Kabelbrücke	15 wire connection	15 cablaggio	15 racord de cable
16 Zündkerze	16 spark plug	16 candela	16 bougie
17 Zündspule	17 ignition coil	17 bobina d'accens	17 bobine d'allumage
18 Generator	18 generator	18 dinamo	18 generateur
19 Kondensator	19 capacitor	19 condensatore	19 condensateur
20 Spannungsregler	20 voltage regulator	20 regol di tens	20 regulateur
21 Batterie 1 2Ah	21 battery 1 2Ah	21 batteria 1 2Ah	21 batterie 1 2Ah
22 Stecksicherung 10A	22 fuse 10A	22 fusibile 10A	22 fusible 10A
23 9-pol Stecker	23 multip cont plug (9)	23 connettore a 9 poli	23 connect multiple (9)
24 Blinker li hi	24 lampegg post sn	24 lampegg post sn	24 clign arr gauche
25 Blinker re hi	25 blinker right rear	25 lampegg post dx	25 clign arr droit
26 Brems-Schlußlicht	26 rear-stoptlight	26 fanal post di freno	26 feu arr et de stop
27 Temperaturkontrolle	27 temperature control	27 controllo temperatura	27 témoin de temperat
28 Temperaturschalter	28 temperature switch	28 int temperatura	28 contact de temp
29 Not-Aus-Schalter	29 short circuit switch	29 int arresto d'emerg	29 bouton de masse

bl blau	bl blue	bl blu	bl bleu
br braun	br brown	br marrone	br brun
ge gelb	ge yellow	ge giallo	ge jaune
gr grau	gr grey	gr grigio	gr gris
g grün	g green	g verde	g vert
o orange	o orange	o arancione	o orange
r rot	r red	r rosso	r rouge
s schwarz	s black	s nero	s noir
v violett	v violet	v violetto	v violet
w weiß	w white	w bianco	w blanc

Kontaktbelegung -

Kombischalter (Typ CEV 100826000)

	s	br	v	r-w	bl	gr	ge/s
TURN L					•		
TURN R					•		
LIGHTS	•						
H LO		•					•
H HI		•					•
HORN		•					•
PASSING		•	•				•

Kontaktbelegung Zündschloß (Typ CEV 7-pol)

	1	2	3	4	5	6	7
PARK	•		•			•	
AUS			•				
EIN	•				•		
EIN	•				•		

Kontaktbelegung Not-Aus-Schalter (Typ CEV 6302)

	s	bl
RUN		•
OFF	•	

12V 130W
SEM K11/60 EG 05
Linkslaufend

SERVICE

Modell 400/620 LC4 EXC '96 (o Batt)

Kabelstrangnummer
vorne 583 11 475 100
hinten 583 11 476 000

Land
BRD

Datum, Name
16 10 95 EK

Zeichnungsnr
42
46S608C-

Änderungsstand

Kabelstrangbez
vo 4T E-GS 95
hi CEV 358 m Bl

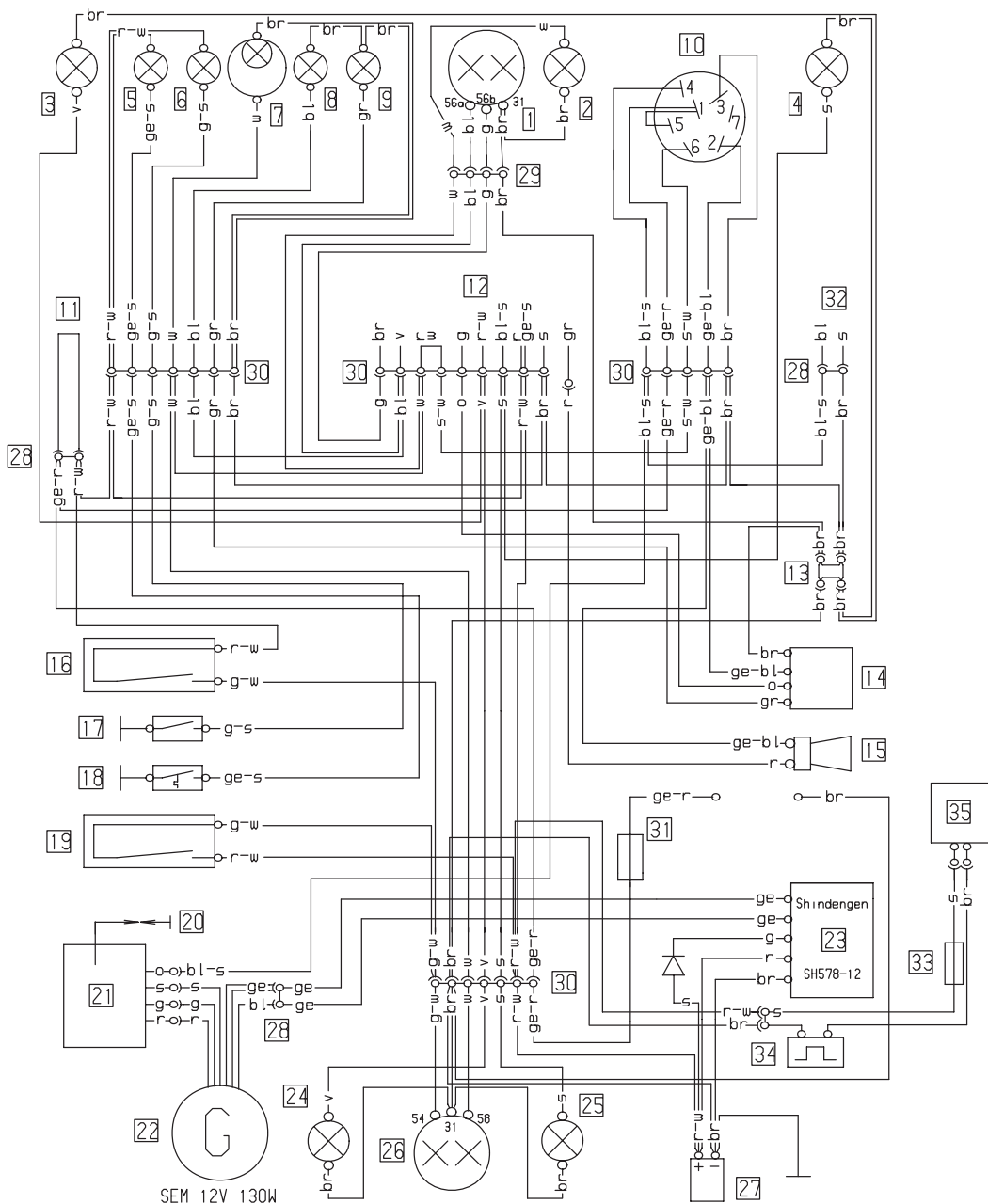

Deutsch	Englisch	Italienisch	Französisch
1 Scheinwerfer	1 headlight	1 faro	1 phare
2 Standlicht	2 parking light	2 luce di posizione	2 feu de position
3 Blinker li vo	3 blinker left front	3 lampegg ant sn	3 clignoteur av gauche
4 Blinker re vo	4 blinker right front	4 lampegg ant dx	4 clignoteur av droit
5 Temperaturkontrolle	5 temperature control	5 controllo temperat	5 témoin d temperature
6 Leerlaufanzeige	6 neutral	6 indicat marcia folle	6 ind de point mort
7 Tachometerleuchtung	7 tachometer light	7 luce di tachimetro	7 éclair comp vitesse
8 Fernlichtkontrolle	8 high beam control	8 spia abbagliante	8 témoin de feu route
9 Blinkerkontrolle	9 blink control	9 spia lampeggiatori	9 témoin de clignoteur
10 Zündschloß	10 ignition switch	10 int accensione	10 contacteur d'allum
11 Kabelbrücke	11 wire connection	11 cablaggio	11 raccord de cable
12 zum Kombischalter	12 to combinat switch	12 multicomando	12 commutateur
13 Masseanschluß	13 ground connection	13 collegam a massa	13 masse
14 Blinkgeber	14 blink signal system	14 trasmett di lampeg	14 centrale clignot
15 Horn	15 horn	15 clacson	15 klaxon
16 Bremslichtsch vo	16 stoplight switch f	16 int luce arresto ant	16 cont de stop av
17 Leerlaufschalter	17 neutral switch	17 interr luce folle	17 contact de pt mort
18 Temp-schalter	18 temperature switch	18 int temperatura	18 sonde de temp
19 Bremslichtsch hi	19 stoplight switch r	19 int luce arresto post	19 cont de stop arr
20 Zündkerze	20 spark plug	20 candela	20 bougie
21 Zündspule	21 ignition coil	21 bobina d'accens	21 bobine d'allumage
22 Generator	22 generator	22 dinamo	22 generateur
23 Spannungsregler	23 voltage regulator	23 regol di tens	23 regulateur
24 Blinker li hi	24 blinker left rear	24 lampegg post sn	24 clign arr gauche
25 Blinker re hi	25 blinker right rear	25 lampegg post dx	25 clign arr droite
26 Brems-Schlußlicht	26 rear-stoplight	26 fanal post di freno	26 feu arr et de stop
27 Kondensator	27 capacitor	27 condensatore	27 condensateur
28 2-pol Stecker	28 multip cont plug (2)	28 connettore a 2 poli	28 connect multiple (2)
29 4-pol Stecker	29 multip cont plug (4)	29 connettore a 4 poli	29 connect multiple (4)
30 9-pol Stecker	30 multip cont plug (9)	30 connettore a 9 poli	30 connect multiple (9)
31 Stecksicherung 10A	31 fuse 10A	31 fusibile 10A	31 fusible 10A
32 Kurzschlußschalter	32 short circuit switch	32 com corto circuito	32 bouton de masse
33 Stecksicherung 5A	33 fuse 5A	33 fusibile 5A	33 fusible 5A
34 Thermoschalter	34 temperature switch	34 termointerruttore	34 sonde de temp
35 Ventilator	35 fan	35 ventilatore	35 ventilateur

bl	blau	bl	bleu
br	brown	br	brun
ge	gelb	ge	giallo
gr	grau	gr	gris
g	grün	g	verde
o	orange	o	arancione
r	rot	r	rosso
s	schwarz	s	nero
v	violett	v	violetto
w	weiß	w	bianco

Kontaktbelegung - Kombischalter (Typ CEV 100826000)

	s	br	v	r-w	s-bl	g	gr	r/ge
TURN L								
TURN R								
LIGHTS								
H LQ								
H HI								
HORN								
PASSING								

Kontaktbelegung Kurzschlußschalter (Typ CEV 6302)

ENGINE	s	bl
RUN		
OFF		

Kontaktbelegung Zündschloß (Typ CEV 7-pol)

	1	2	3	4	5	6	7
PARK							
AUS							
EIN							
EIN							

SERVICE

Modell

400/620 E-GS '96

Kabelstrangnummer

vorne 583 11 475 200
hinten 583 11 476 000

Land

AUSTRALIEN

Datum, Name

19 10 95 KE

Zeichnungsnr

46S60BSA

Änderungsstand

Kabelstrangbez

vo EGS Austr
hi 4-T EGS

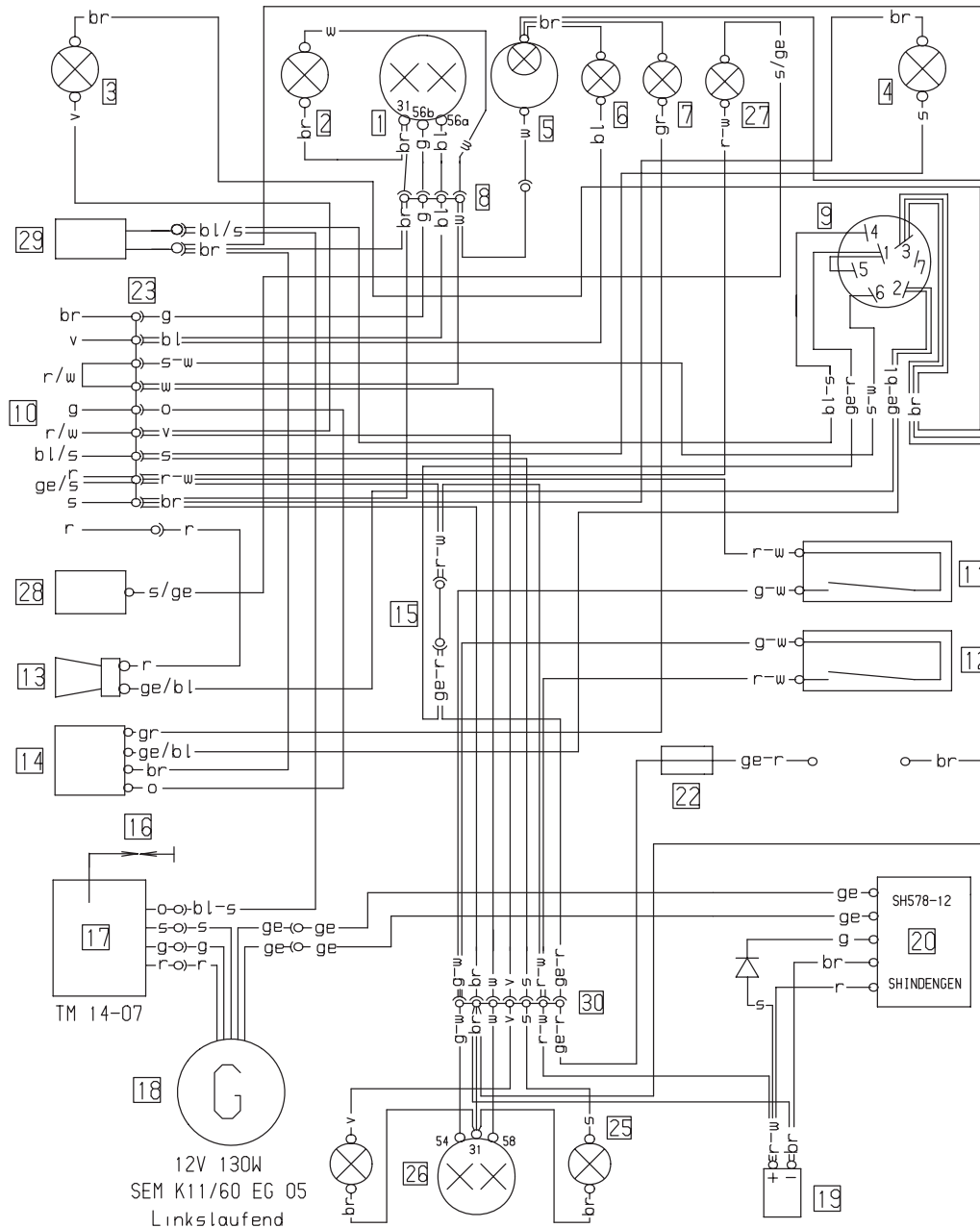

Deutsch	Englisch	Italienisch	Französisch
1 Scheinwerfer	1 headlight	1 fano	1 phare
2 Standlicht	2 parking light	2 luce di posizione	2 feu de position
3 Blinker li vo	3 blinker left front	3 lampegg ant sn	3 clignoteur av gauche
4 Blinker re vo	4 blinker right front	4 lampegg ant dx	4 clignoteur av droit
5 Tachobeleuchtung	5 tachometer light	5 luce di tachmetro	5 éclair comp vitesse
6 Fernlichtkontrolle	6 high beam control	6 spia abbagliante	6 témoin feu route
7 Blinkerkontrolle	7 blink control	7 spia lampeggiatori	7 témoin de clignoteur
8 4-pol Stecker	8 multip cont plug (4)	8 connettore a 4 poli	8 connecteur multiple (4)
9 Zündschloß	9 ignition switch	9 int accensione	9 contact d'allum
10 zum Kombischalter	10 to combinat switch	10 multicomando	10 commodo
11 Bremslichtsch vo	11 stoptlight switch f	11 int luce arresto ant	11 contact de stop av
12 Bremslichtsch hi	12 stoptlight switch r	12 int luce arresto post	12 contact de stop
13 Horn	13 horn	13 clacson	13 klaxon
14 Blinkgeber	14 blink signal system	14 centrale di lampeg	14 centrale clignot
15 Kabelbrücke	15 wire connection	15 cablaggio	15 racord de cable
16 Zündkerze	16 spark plug	16 candela	16 bougie
17 Zündspule	17 ignition coil	17 bobina d'accens	17 bobine d'allumage
18 Generator	18 generator	18 dinamo	18 generateur
19 Kondensator	19 capacitor	19 condensatore	19 condensateur
20 Spannungsregler	20 voltage regulator	20 regol di tens	20 regulateur
21 Batterie 1 2Ah	21 battery 1 2Ah	21 batteria 1 2Ah	21 batterie 1 2Ah
22 Stecksicherung 10A	22 fuse 10A	22 fusibile 10A	22 fusible 10A
23 9-pol Stecker	23 multip cont plug (9)	23 connettore a 9 poli	23 connect multiple (9)
24 Blinker li hi	24 lampegg post sn	24 lampegg post sn	24 clign arr gauche
25 Blinker re hi	25 blinker right rear	25 lampegg post dx	25 clign arr droit
26 Brems-Schlußlicht	26 rear-stoptlight	26 fanal post di freno	26 feu arr et de stop
27 Temperaturkontrolle	27 temperature control	27 controllo temperatura	27 témoin de temperat
28 Temperaturschalter	28 temperature switch	28 int temperatura	28 contact de temp
29 Not-Aus-Schalter	29 short circuit switch	29 int arresto d'emerg	29 bouton de masse

bl blau	bl blue	bl blu	bl bleu
br braun	br brown	br marrone	br brun
ge gelb	ge yellow	ge giallo	ge jaune
gr grau	gr grey	gr grigio	gr gris
g grün	g green	g verde	g vert
o orange	o orange	o arancione	o orange
r rot	r red	r rosso	r rouge
s schwarz	s black	s nero	s noir
v violett	v violet	v violetto	v violet
w weiß	w white	w bianco	w blanc

Kontaktbelegung -
Kombischalter (Typ CEV 100826000)

	s	br	v	r-w	bl	gr	ge/s
TURN L					•		
TURN R					•		
LIGHTS	•						
H LO		•					•
H HI		•					•
HORN		•					•
PASSING		•	•				•

Kontaktbelegung
Zündschloß (Typ CEV 7-pol)

	1	2	3	4	5	6	7
PARK	•		•			•	
AUS			•				
EIN	•				•		
EIN	•				•		

Kontaktbelegung
Not-Aus-Schalter (Typ CEV 6302)

	s	bl
RUN	•	
OFF	•	•