

# 950 Super Enduro

## ECU

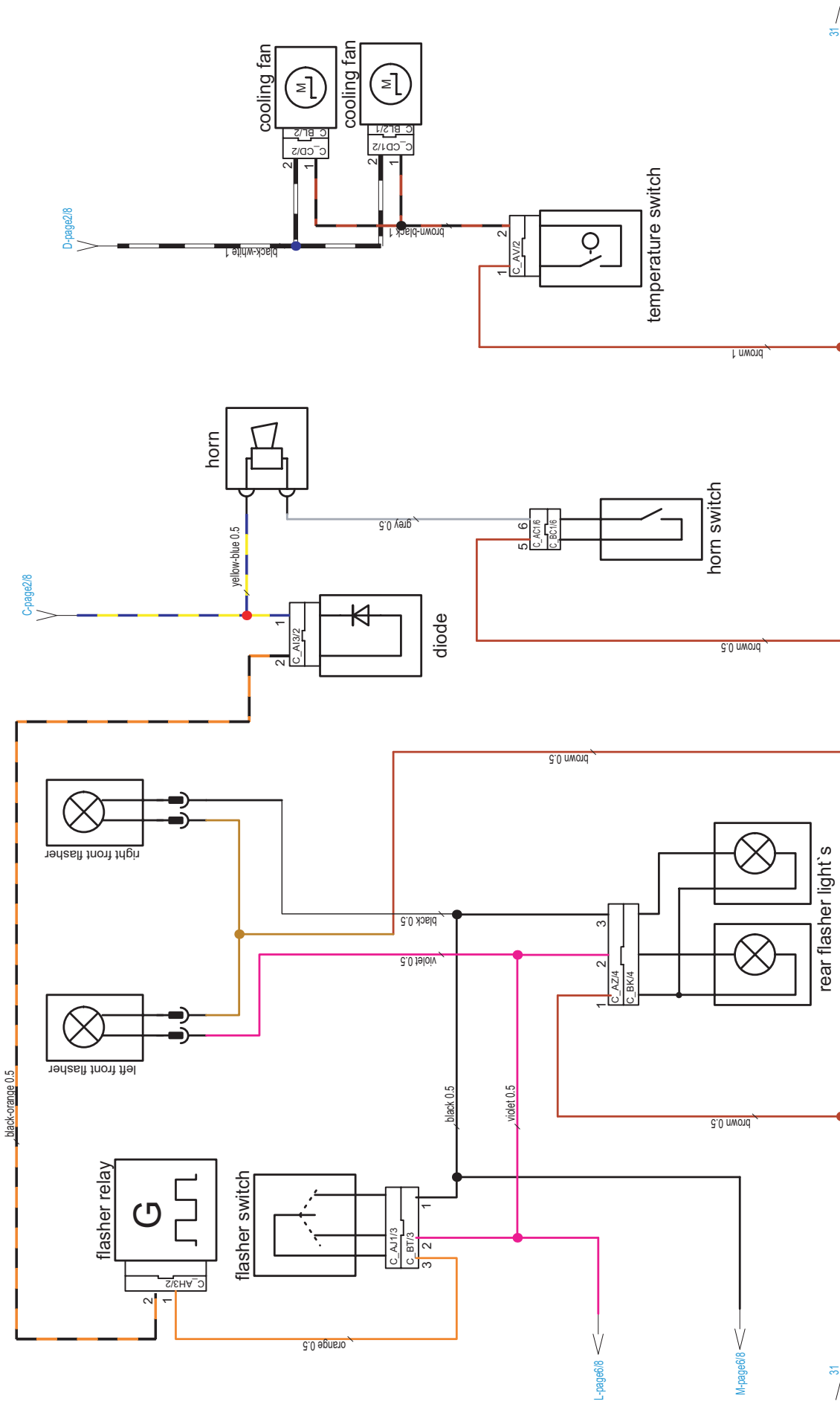

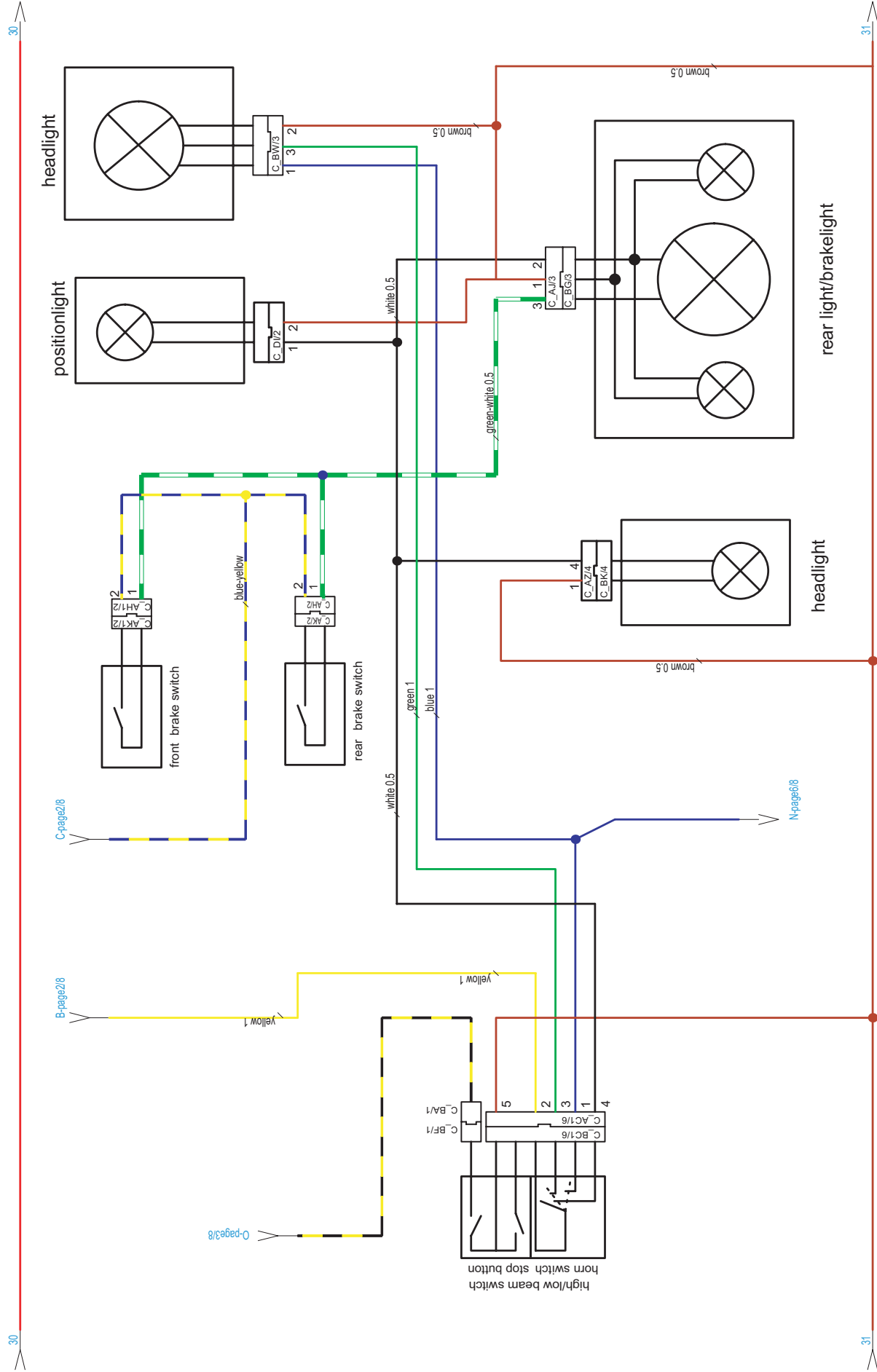

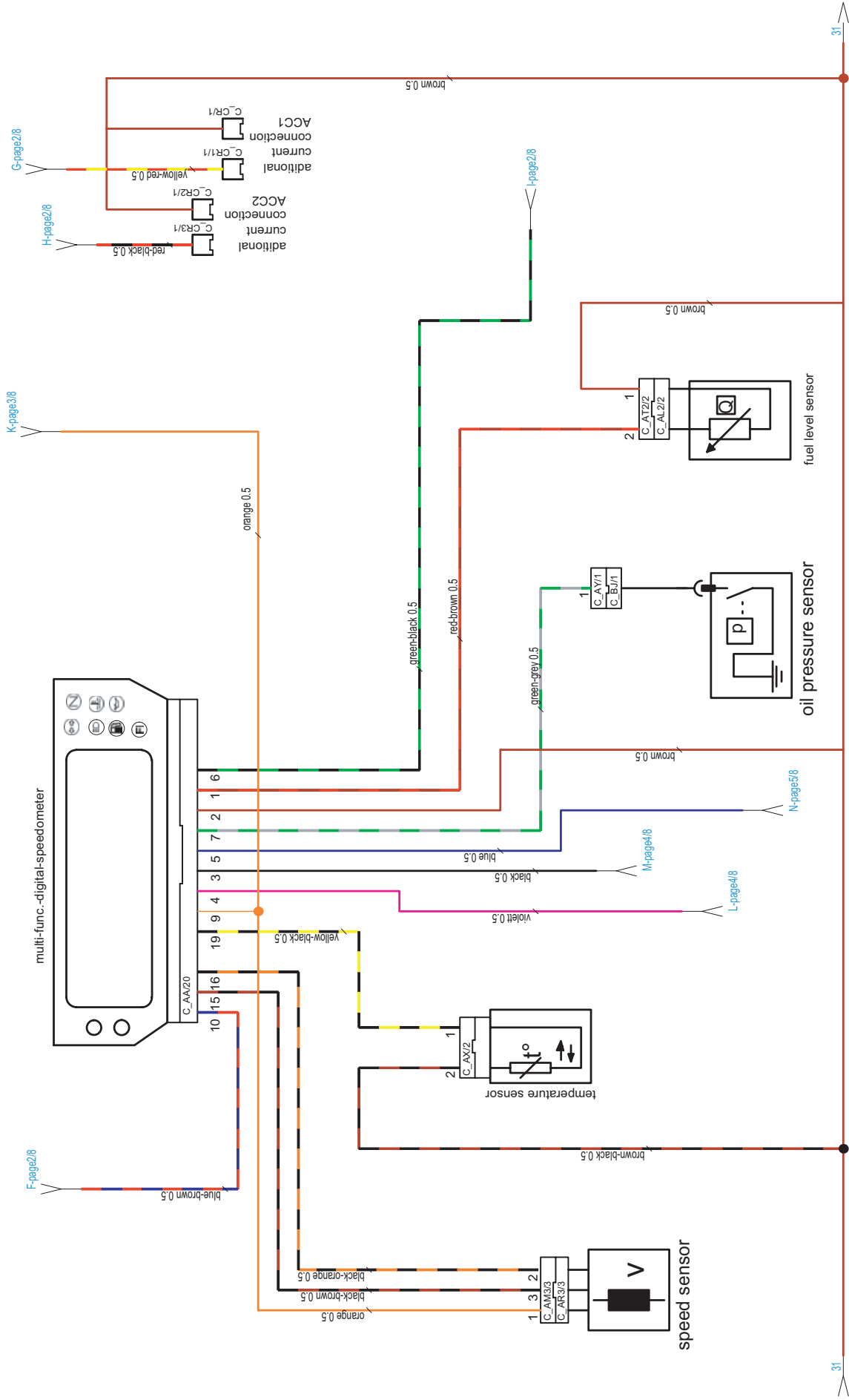

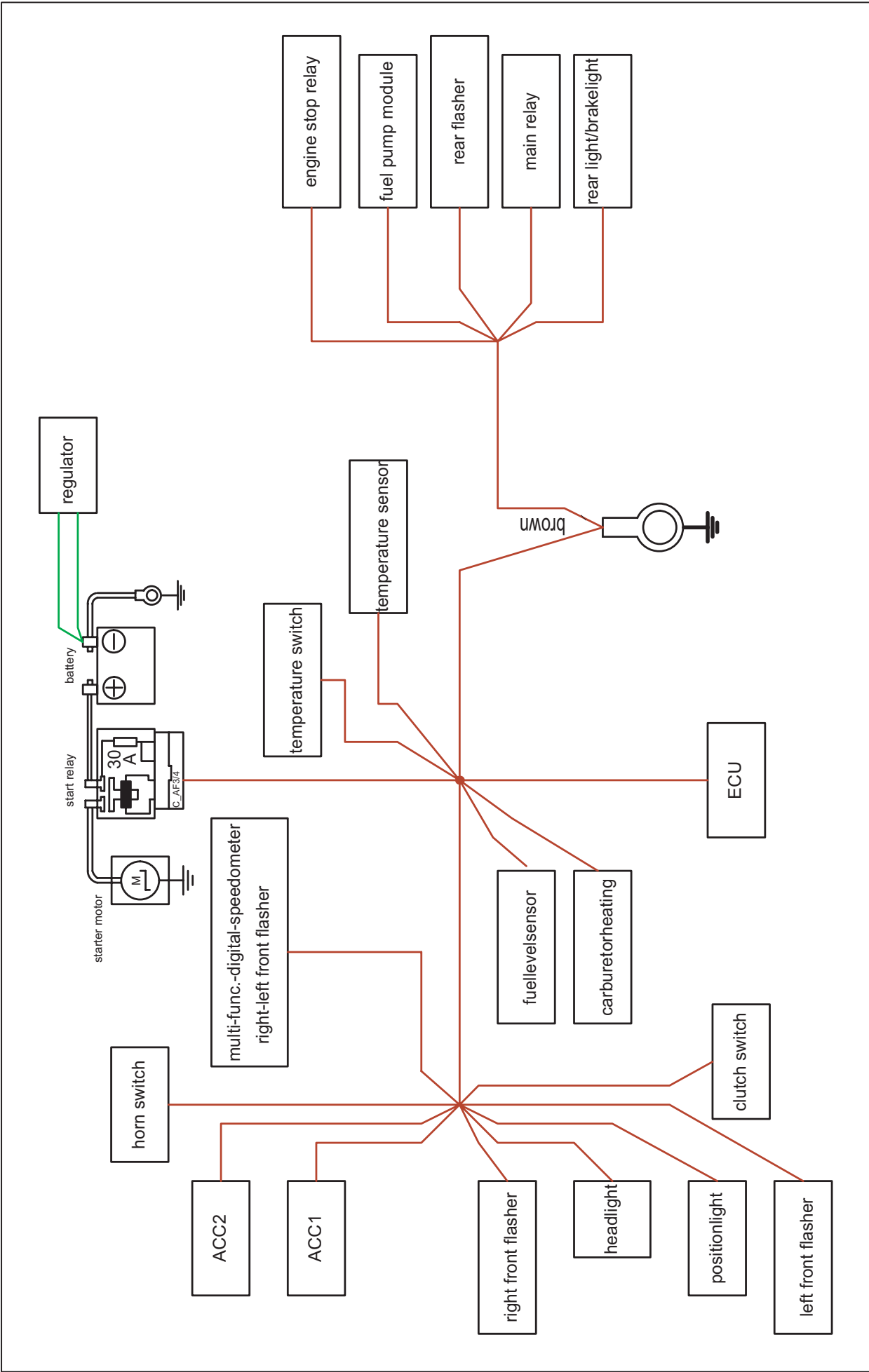

950 Super Enduro

instruments-tachometer



	<p>950 Super Enduro</p>	<p>ground connection</p>	<p>7/8</p>
---	-------------------------	--------------------------	------------

