

# 990 SUPERDUKE 2012





**SPARE PARTS MANUAL: ENGINE**

ART.NO.: 3CM089820LEN

ENGLISH

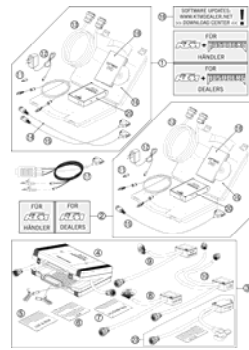
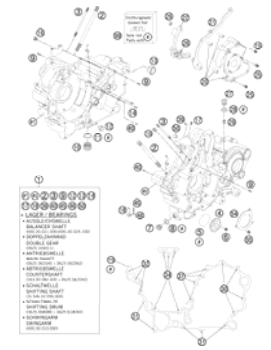
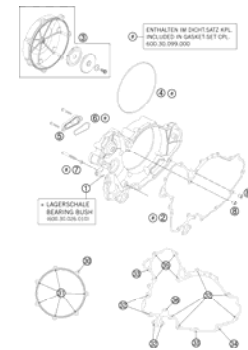
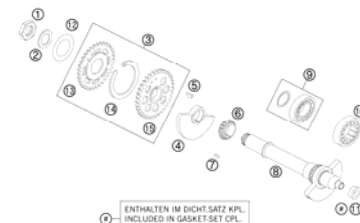
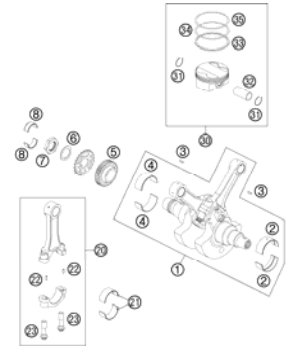
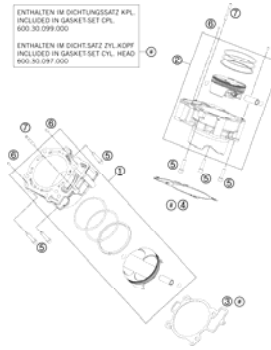
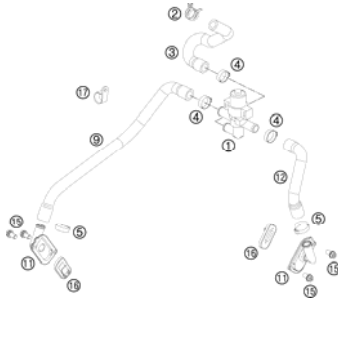
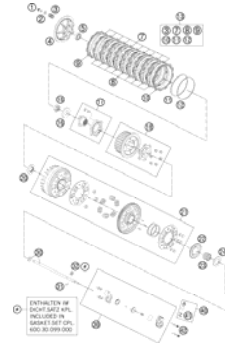

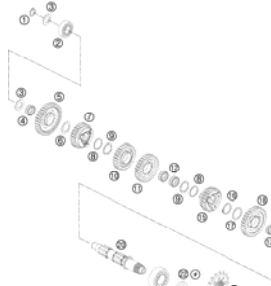

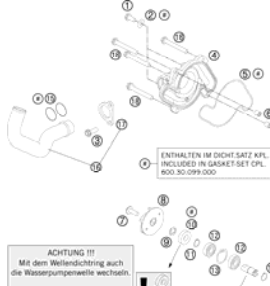
<p><b>DIAGNOSTIC TOOL</b></p>  <p>SOFTWARE UPDATES FROM HANDBLER OR IN DOWNLOAD CENTER FOR HANDLE FOR DEALER</p> <p>3</p>	<p><b>ENGINE CASE</b></p>  <p>ENTHALTEN IM DICHTSATZ KPL. INCLUDED IN GASKET SET CPL. 600.30.099.000</p> <p>4</p>	<p><b>CLUTCH COVER</b></p>  <p>ENTHALTEN IM DICHTSATZ KPL. INCLUDED IN GASKET SET CPL. 600.30.099.000</p> <p>6</p>	<p><b>BALANCER SHAFT</b></p>  <p>ENTHALTEN IM DICHTSATZ KPL. INCLUDED IN GASKET SET CPL. 600.30.099.000</p> <p>7</p>
<p><b>CRANKSHAFT, PISTON</b></p>  <p>8</p>	<p><b>CYLINDER</b></p>  <p>ENTHALTEN IM DICHTUNGSSATZ KPL. INCLUDED IN GASKET SET CPL. 600.30.099.000</p> <p>ENTHALTEN IM DICHTSATZ ZYL. KOPF INCLUDED IN GASKET SET CYL. HEAD 600.30.099.000</p> <p>9</p>	<p><b>SECONDARY AIR SYSTEM SAS</b></p>  <p>10</p>	<p><b>CLUTCH</b></p>  <p>ENTHALTEN IM DICHTSATZ KPL. INCLUDED IN GASKET SET CPL. 600.30.099.000</p> <p>11</p>
<p><b>TRANSMISSION I - MAIN SHAFT</b></p>  <p>12</p>	<p><b>TRANSMISSION II - COUNTERSHAFT</b></p>  <p>ENTHALTEN IM DICHTSATZ KPL. INCLUDED IN GASKET SET CPL. 600.30.099.000</p> <p>13</p>	<p><b>SHIFTING MECHANISM</b></p>  <p>ENTHALTEN IM DICHTSATZ KPL. INCLUDED IN GASKET SET CPL. 600.30.099.000</p> <p>14</p>	<p><b>WATER PUMP</b></p>  <p>ENTHALTEN IM DICHTSATZ KPL. INCLUDED IN GASKET SET CPL. 600.30.099.000</p> <p>ACHTUNG !!! Mit dem Wellendichtring auch die Wasserpumpenwelle wechseln. CAUTION !!! With the shaft seal ring also change the water-pump shaft.</p> <p>16</p>

**COOLING SYSTEM**

**17**

**VALVE DRIVE**

EXHAUST INTAKE

Markierungsrille  
Marking groove

Ventilfedern sind gelb-blau markiert  
Valve springs have yellow and blue marking

ENTHALTEN IM DICHTUNGSSATZ KPL.  
INCLUDED IN GASKET-SET CPL.  
600.30.099.000  
ENTHALTEN IM DICHTSATZ ZYL. KOPF  
INCLUDED IN GASKET-SET CYL. HEAD  
600.30.097.000

**19**

**TIMING DRIVE**

ENTHALTEN IM DICHTUNGSSATZ KPL.  
INCLUDED IN GASKET-SET CPL.  
600.30.099.000  
ENTHALTEN IM DICHTSATZ ZYL. KOPF  
INCLUDED IN GASKET-SET CYL. HEAD  
600.30.097.000

**20**

**CYLINDER HEAD FRONT**

DICHTUNGSSATZ KPL. 600.30.099.000  
INHALT DICHTSATZ ZYL. KOPF 600.30.097.000  
GASKET-SET CPL. 600.30.099.000  
INCL. GASKET-SET CYL. HEAD 600.30.097.000

ENTHALTEN IM DICHTUNGSSATZ KPL.  
INCLUDED IN GASKET-SET CPL.  
600.30.099.000  
ENTHALTEN IM DICHTSATZ ZYL. KOPF  
INCLUDED IN GASKET-SET CYL. HEAD  
600.30.097.000

ZYLINDER VORNE  
CYLINDER FRONT

**21**

**CYLINDER HEAD REAR**

DICHTUNGSSATZ KPL. 600.30.099.000  
ENTHALT DICHTSATZ ZYL. KOPF 600.30.097.000  
GASKET-SET CPL. 600.30.099.000  
INCL. GASKET-SET CYL. HEAD 600.30.097.000

Dichtungssatz Zylinder  
Gasket set Cylinder  
-ZYL. KOPF  
-KOPF  
-KOPF  
-KOPF

ZYLINDER HINTEN  
CYLINDER REAR

**23**

**LUBRICATING SYSTEM**

ENTHALTEN IM DICHTSATZ KPL.  
INCLUDED IN GASKET-SET CPL.  
600.30.099.000

**24**

**IGNITION SYSTEM**

ENTHALTEN IM DICHTSATZ KPL.  
INCLUDED IN GASKET-SET CPL.  
600.30.099.000

ENTHALTEN IM DICHTSATZ KPL.  
INCLUDED IN GASKET-SET CPL.  
600.30.099.000

ENTHALTEN IM DICHTSATZ KPL.  
INCLUDED IN GASKET-SET CPL.  
600.30.099.000

ENTHALTEN IM DICHTSATZ KPL.  
INCLUDED IN GASKET-SET CPL.  
600.30.099.000

ENTHALTEN IM DICHTSATZ KPL.  
INCLUDED IN GASKET-SET CPL.  
600.30.099.000

**26**

**ELECTRIC STARTER**

ENTHALTEN IM DICHTSATZ KPL.  
INCLUDED IN GASKET-SET CPL.  
600.30.099.000

**27**

**THROTTLE BODY**

**28**

**!**

All information contained is without obligation. KTM-Sportmotorcycle AG particularly reserves the right to modify any equipment, technical specifications, prices, colors, shapes, materials, services, service work, constructions, equipment and the like so as to adapt them to local conditions or to cancel any of the above items, all without previous announcement and without giving reasons. KTM may stop manufacturing certain models without previous notice. KTM shall not be held liable for any deviations of availability and/or ability to deliver, illustrations, descriptions, printing and/or other errors. The illustrated models partly contain extra equipment, which is not applied to standard models. © by KTM-SPORTMOTORCYCLE AG, Mattighofen AUSTRIA; All rights reserved; Reprint, also in extracts, with written allowance of KTM-SPORTMOTORCYCLE AG, Mattighofen only.

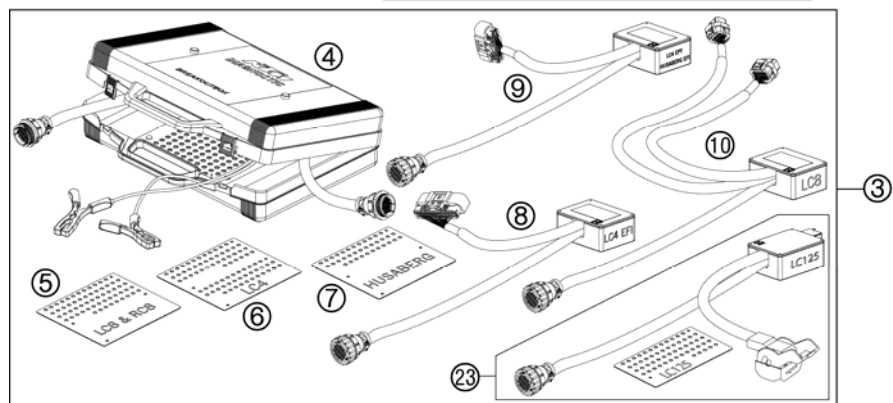
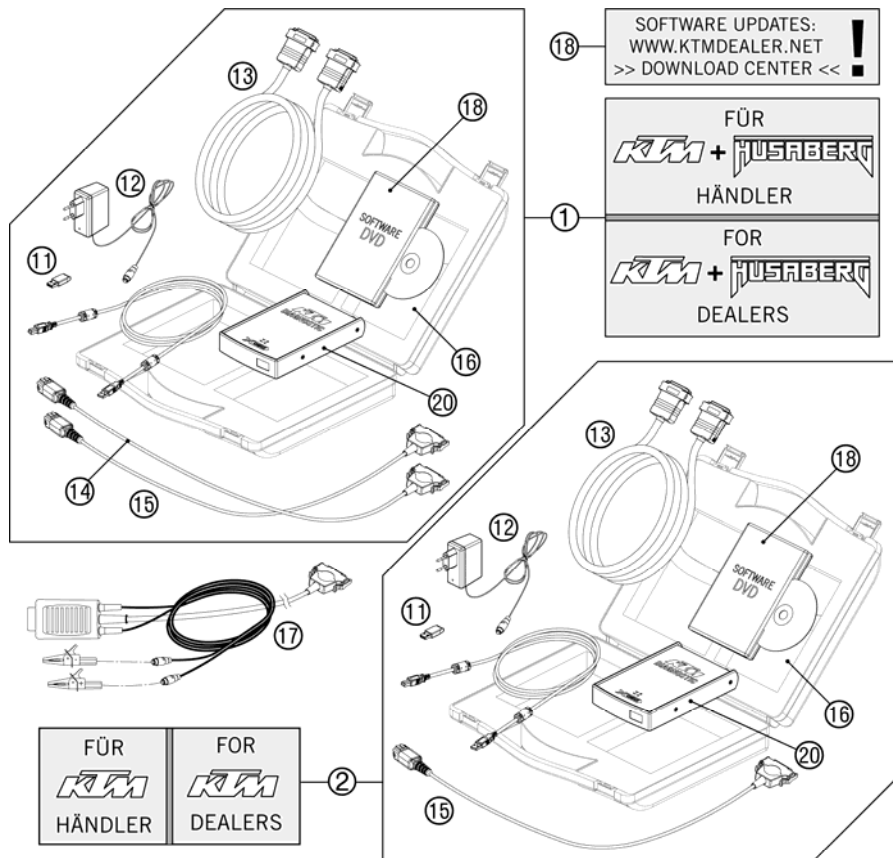

FIG	PART NUMBER	DESCRIPTION	QTY
1	00029096200	DIAGNOSTIC TOOL HUSABERG/KTM	1
2	00029096100	DIAGNOSTIC TOOL KTM	1
3	00029095000	BREAKOUT-BOX KPL.	1
4	00029095001	BREAKOUT-BOX	1
5	00029095005	TEMPLATE LC8 / RC8	1
6	00029095006	TEMPLATE LC4	1
7	00029095007	TEMPLATE HUSABERG	1
8	00029095003	ADAPTER LC4 EFI	1
9	00029095004	ADAPTER LC4 EPT/HUSABERG EFI	1
10	00029095002	ADAPTER LC8	1
11	00029096006	DIAGNOSTIC HASP DONGLE XC1	2
12	00029096003	POWERSUPPLY 220V/12V FOR AVL	2
13	00029096002	EXTENSION CABLE	2
14	00029096001	DIAGNOSTIC CABLE HUSABERG	1
15	00029096009	DIAGNOSTIC CABLE KTM	2
16	00029096004	CASE FOR DIAGNOSTIC-TOOL	1
17	00029096010	DIAGN. CABLE EXT. POWER SUPPLY	1
18	00029096007	DVD KTM XC-1 UPDATE V2.0	2
20	00029096011	FRAME XC_1 SCANBOX KTM	1
23	00029095009	ADAPTER LC125	1

100002921 / C100002921

\* NEW PART

X AS REQUIRED

# ENGINE CASE

# 990 SUPERDUKE 2012

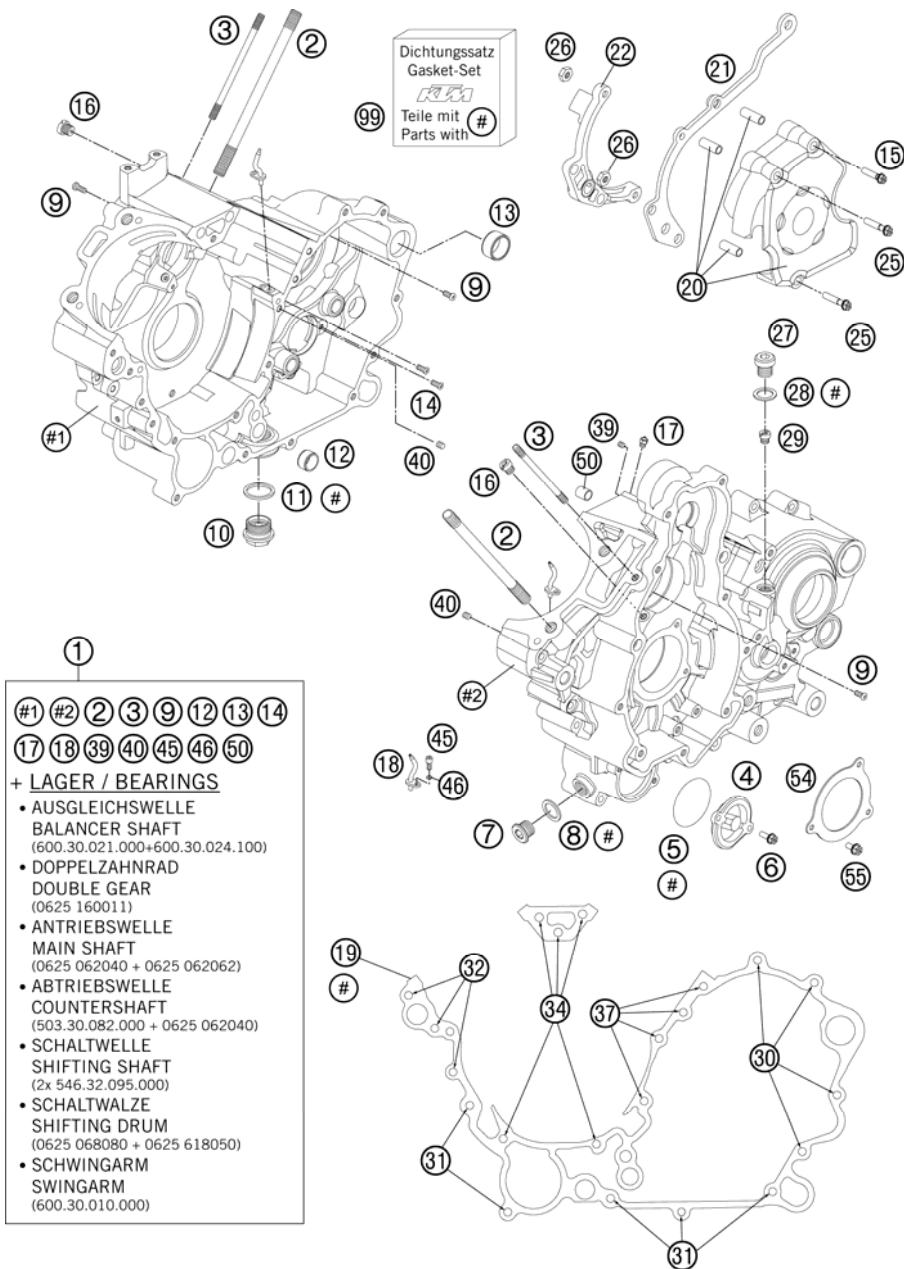

FIG	PART NUMBER	DESCRIPTION	QTY
1	6003000014423	ENGINE CASE CPL. 05	1
2	60030043100	STUD M10X161 06	8
3	60030043010	STUD M 6X101 10.9 03	2
4	75038041200	OILFILTER CAP	1
5	07700390261	O-RING 39,34X2,62	1
6	0025050166	HH COLLAR SCREW M5X16 TX30	2
7	60038033050	PLUG SCREW M14X1,5 ALU AH	1
8	0603142016	CU-SEAL RING 14X20X1,5 LC8 02	1
9	0018050103	INT. TORX OVAL HEAD M 5X10 8.8	3
10	58038019050	DRAIN PLUG W. MAGNET	1
11	58038017100	CU-SEAL RING DIN7603-22X27X2	1
12	58330023000	DOWEL 17 X 14 X 9,5	1
13	60030023000	DOWEL 20,1X24X12 03	1
14	0019050103	INT. TORX FLAT HEAD M 5X10 8.8	2
15	0025060306	HH COLLAR SCREW M6X30 TX30	1
16	59030054000	JET 60 DELLORTO M6X0,75	2
17	60030063070	OIL JET 70 M5	2
18	60030064000	OIL INJECT.TUBE CURVED "70" 05	2
19	60030039100	ENGINE CASE GASKET 0,5MM 05	1
20	60030060044	CHAIN SPROCKET COVER CPL. 03	1
21	60030047000	CHAIN FAIL. PROTECTION LC8 03	1
22	60032063000	ADAPTER F. HYDR. CLUTCH 03	1
25	0025060356	HH COLLAR SCREW M6X35 TX30	2
26	0985060003	SELF LOCK. NUT DIN0985-M 6	2
27	49030029000	OIL DRAIN PLUG M10X1,5 AH-WS=6	1
28	0603100141	COPPER GASKET DIN7603-10X14X1	1
29	60038029200	REDUCING JET "30" M6X0,75	1
30	0025060406	HH COLLAR SCREW M6X40 TX30	4
31	0025060606	HH COLLAR SCREW M6X60 TX30	5
32	0025060656	HH COLLAR SCREW M6X65 TX30	3
34	0025060706	HH COLLAR SCREW M6X70 TX30	5
37	0025060906	HH COLLAR SCREW M6X90 TX30	4
39	0916050042	THREAD PIN DIN916 M5X4-45H	2
40	0551060050	THREAD PIN DIN0551-M 6X 5	2
45	0912040103	AH.SCREW DIN0912-M 4X10	2

116113010 / C116113010

\* NEW PART

X AS REQUIRED

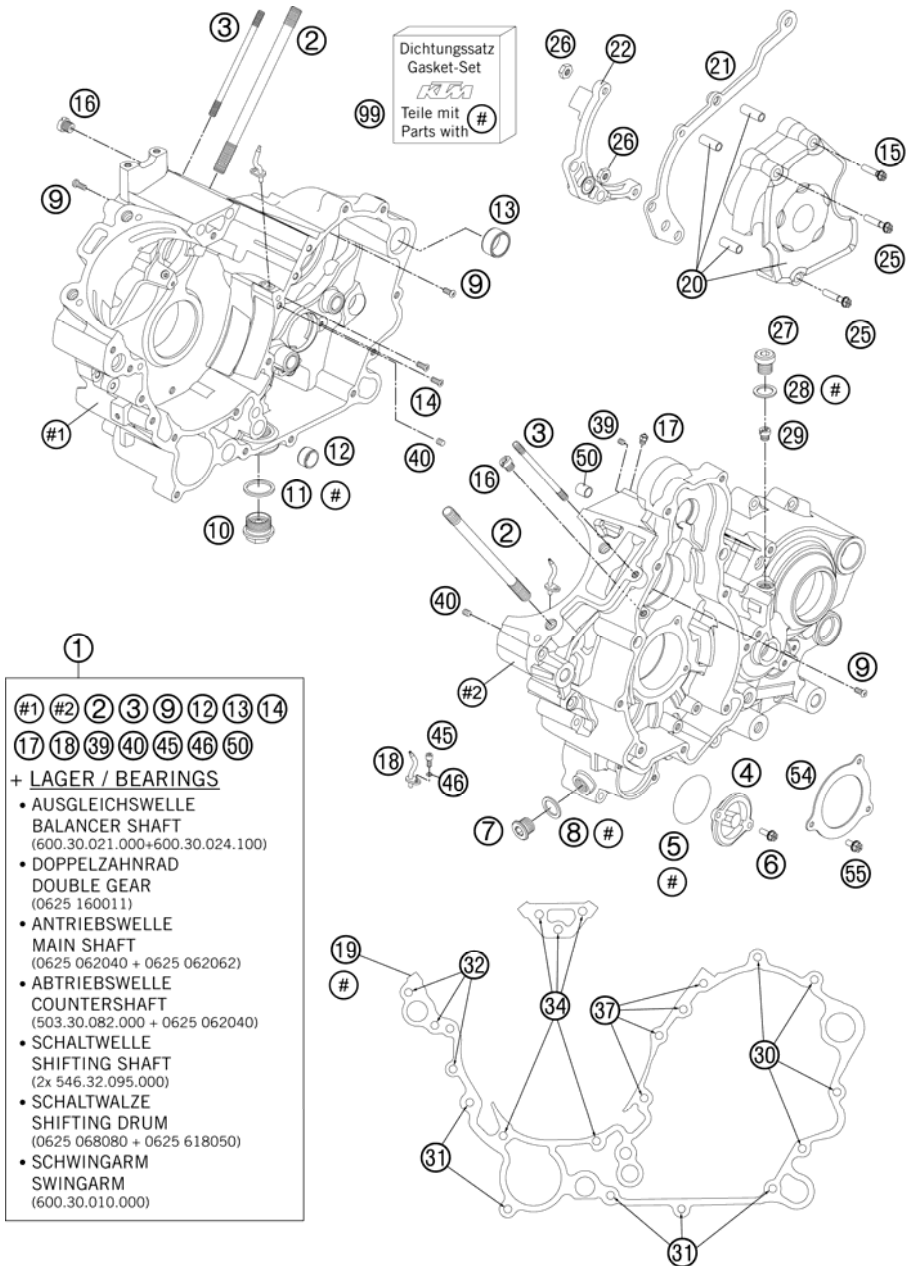

FIG	PART NUMBER	DESCRIPTION	QTY
46	0770035020	O-RING 3,5X2,00 NBR	2
50	49030090000	DOWEL 9,8 X 7 X 10	2
54	60030084000	BRACKET FOR BEARING INSERT 05	2
55	0025050126	HH COLLAR SCREW M5X12 TX30	6
99	60030099000	GASKET SET CPL. 03	1

116113010 / C116113010

\* NEW PART

X AS REQUIRED

# CLUTCH COVER

990 SUPERDUKE 2012

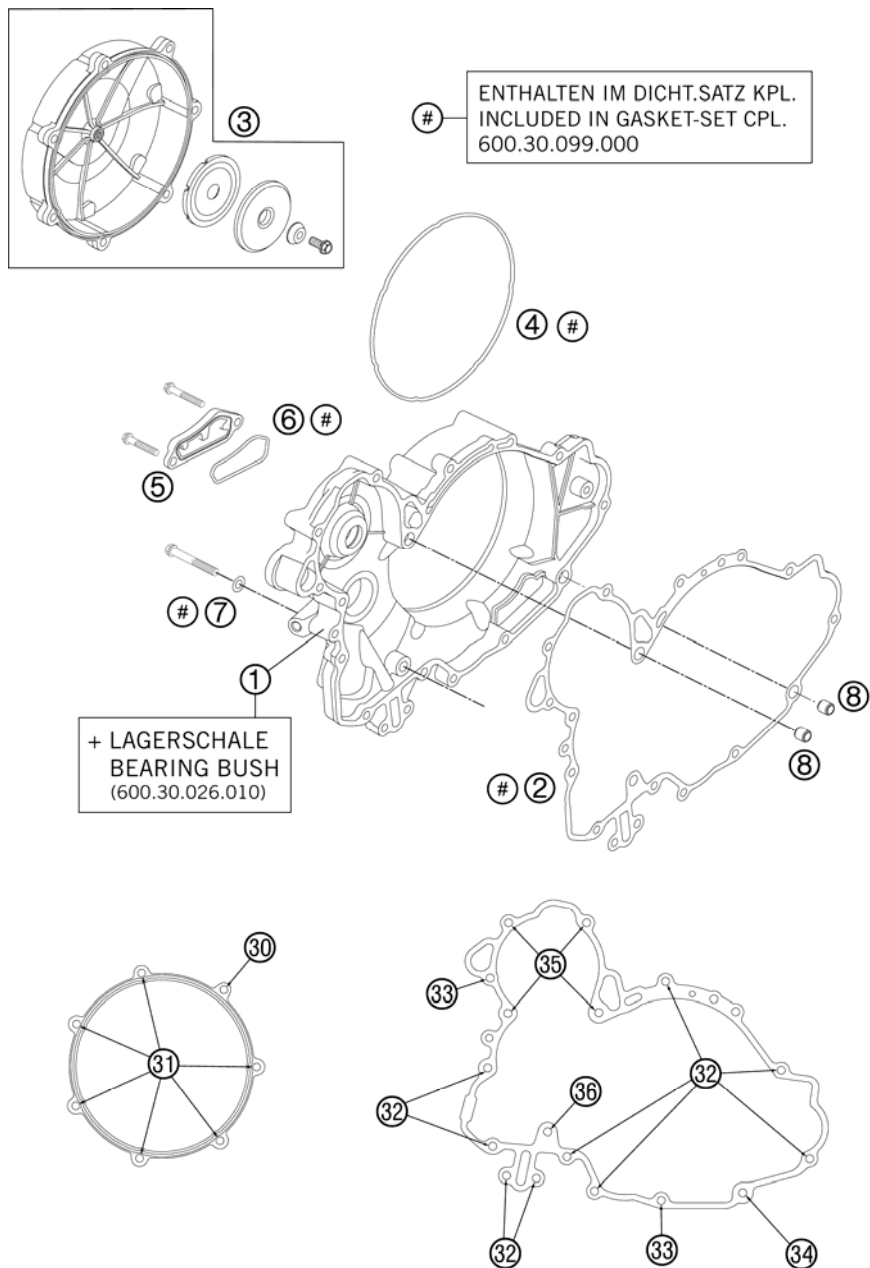

FIG	PART NUMBER	DESCRIPTION	QTY
1	6003000114423	CLUTCH COVER LC8 CPL.08	1
2	60030025000	CLUT.COV. GASK. INSIDE KLI.SIL	1
3	6003012614423	CLUTCH OUTSIDE COVER CPL. 06	1
4	60030027000	GASKET RING CLUTCH 2X3,1 VAMAC	1
5	60030012100	CLOS. COVER OIL SCR. MILLED 03	1
6	60030012050	MOLDED RING 1,8X2,5 VAMAC 03	1
7	0603082131	COPPER GASK.DIN7603- 8,2X13X1	1
8	49030090000	DOWEL 9,8 X 7 X 10	2
30	0025060856	HH COLLAR SCREW M6X85 TX30	1
31	0025060256	HH COLLAR SCREW M6X25 TX30	6
32	0025060306	HH COLLAR SCREW M6X30 TX30	9
33	0025060356	HH COLLAR SCREW M6X35 TX30	2
34	0025060406	HH COLLAR SCREW M6X40 TX30	1
35	0025060606	HH COLLAR SCREW M6X60 TX30	4
36	0025080606	HH COLLAR SCREW M8x60 TX40	1

116113020 / C116113020

\* NEW PART

X AS REQUIRED



# BALANCER SHAFT

990 SUPERDUKE 2012

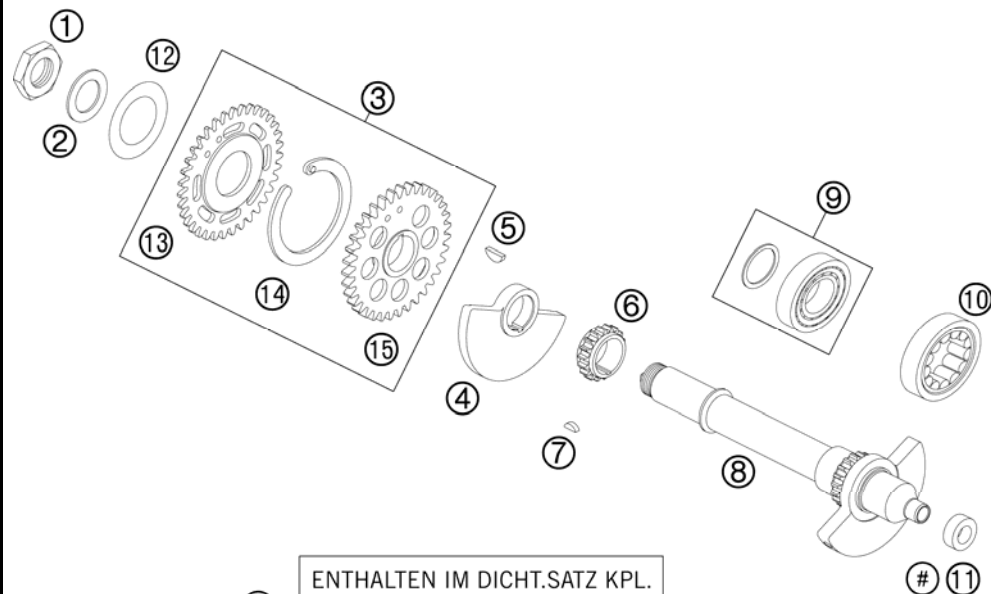

# ENTHALTEN IM DICHT.SATZ KPL.  
INCLUDED IN GASKET-SET CPL.  
600.30.099.000

FIG	PART NUMBER	DESCRIPTION	QTY
1	60036073150	HEXAGON NUT M20X1,5 H=6MM 05	1
2	60033043000	STOP DISK 20,2 X 34 X 1	1
3	60036081000	SPREAD TRANSMISSION 05	1
4	61036074050	BALANCER WEIGHT R/S 05	1
5	0888040050	WOODRUFF KEY DIN6888 4X5X13	1
6	60036014018	TIMING GEAR 18-T 03	1
7	0888030037	WOODRUFF KEY DIN6888-3X3,7	1
8	61036073000	TIMING VALVE JACKSHAFT CPL.	1
9	60030024100	CYL. ROLLER BEAR. NUP 204E	1
10	60030021000	CYL.ROLLER BEARING 26,5X47X14	1
11	0760122050	SHAFT SEAL RING 12X20X5 B	1
12	0093463006	SPRING WASH. 30,5X46,5X0,6-1,5	1
13	60036083035	CLAMPING WHEEL 35-Z 05	1
14	60036081050	TENSION SPRING 05	1
15	60036082035	DRIVE WHEEL 35-T 05	1

116113030 / C116113030

\* NEW PART

X AS REQUIRED

# CRANKSHAFT, PISTON

990 SUPERDUKE 2012

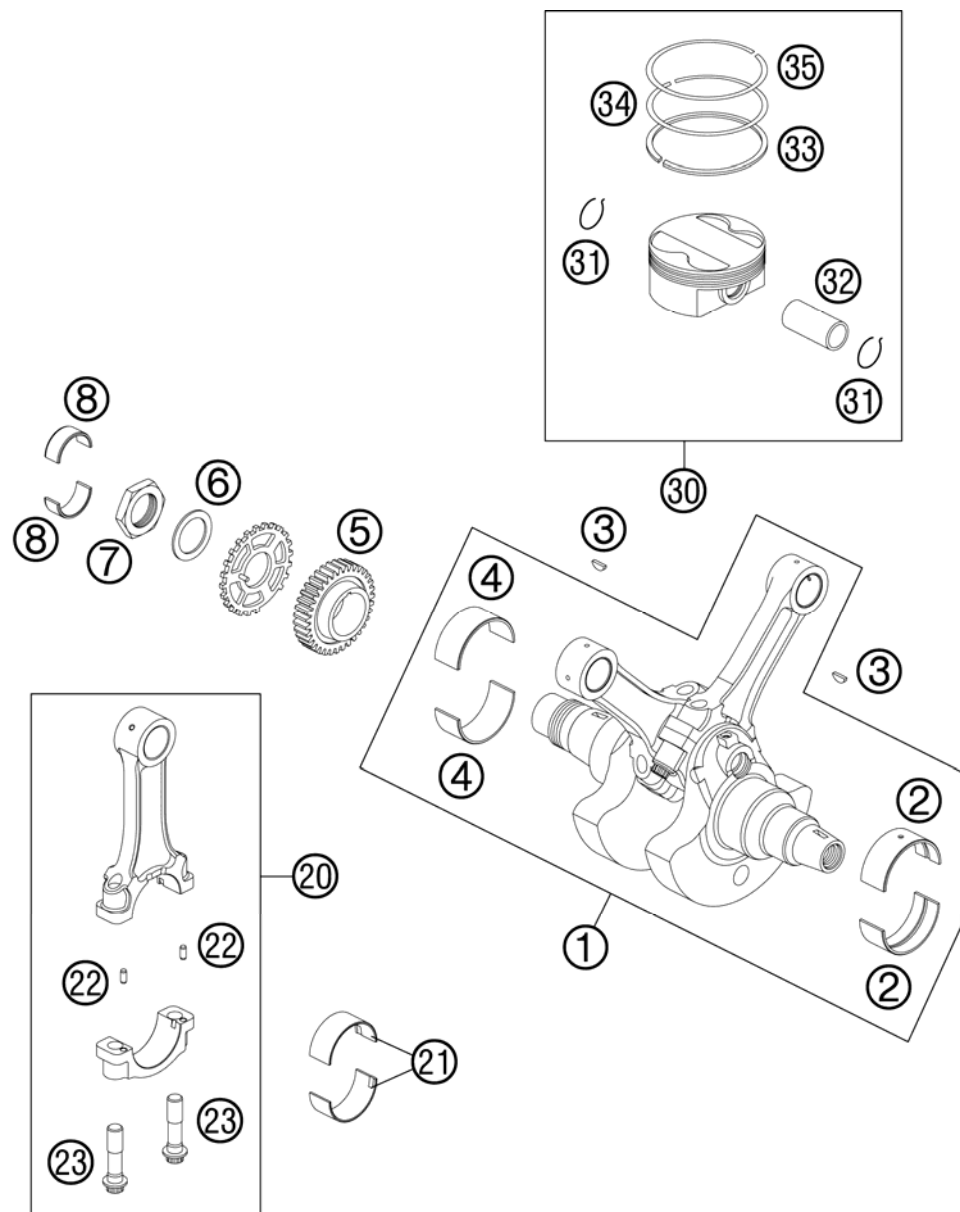

FIG	PART NUMBER	DESCRIPTION	QTY
1	61030018100	CRANKSHAFT KPL.	1
2	60030082000 1	SPLIT BEAR.BUSH SIZE 1 RED 03	x
2	60030082000 2	SPLIT BEAR.BUSH SIZE 2 BLUE 03	x
2	60030082000 3	SPLIT BEAR.BUSH SIZE 3 YELL.03	x
3	0888040050	WOODRUFF KEY DIN6888 4X5X13	2
4	60030182000 1	SPLIT BEAR.BUSH SIZE 1 RED 03	x
4	60030182000 2	SPLIT BEAR.BUSH SIZE 2 BLUE 03	x
4	60030182000 3	SPLIT BEAR.BUSH SIZE 3 YELL.03	x
5	60032023035	PRIMARY PINION 35 T 03	1
6	60032009040	WASHER 33,2X46X2 03	1
7	60032009050	HH-NUT M33X1,5 L/S WS46 03	1
8	60030026010	BUSHING BOWL 28X32X13 03	2
20	60030013244	CONNECTING ROD CPL. 06	2
21	60030013051	BUSH.BOWL PACK. SIZE 1 RED 03	x
21	60030013052	BUSH.BOWL PACK. SIZE 2 BLUE 03	x
21	60030013053	BUSH.BOWL PACK. SIZE 3 YELL.03	x
22	60030015061	CYLINDER PIN 03	4
23	60030015260	CONNECTING-ROD BOLT MJ10X1 06	4
30	61030007000 I	PISTON D=101 05	x
30	61030007000 II	PISTON D=101 05	x
31	77630074000	CIRCLIP	4
32	75030033000	PISTON PIN EB 22/72 d22x56	2
33	61030032000	OIL SCRAPER RING D=101MM	2
34	58330932100	TAP.COMPR.PISTON RING 101X1,25	2
35	61030030000	PISTON RING "L" D=101 H=1,25	2

116113060 / C116113060

\* NEW PART

X AS REQUIRED

# CYLINDER

990 SUPERDUKE 2012

ENTHALTEN IM DICHTUNGSSATZ KPL.  
INCLUDED IN GASKET-SET CPL.  
600.30.099.000

ENTHALTEN IM DICHT.SATZ ZYL.KOPF  
INCLUDED IN GASKET-SET CYL. HEAD  
600.30.097.000

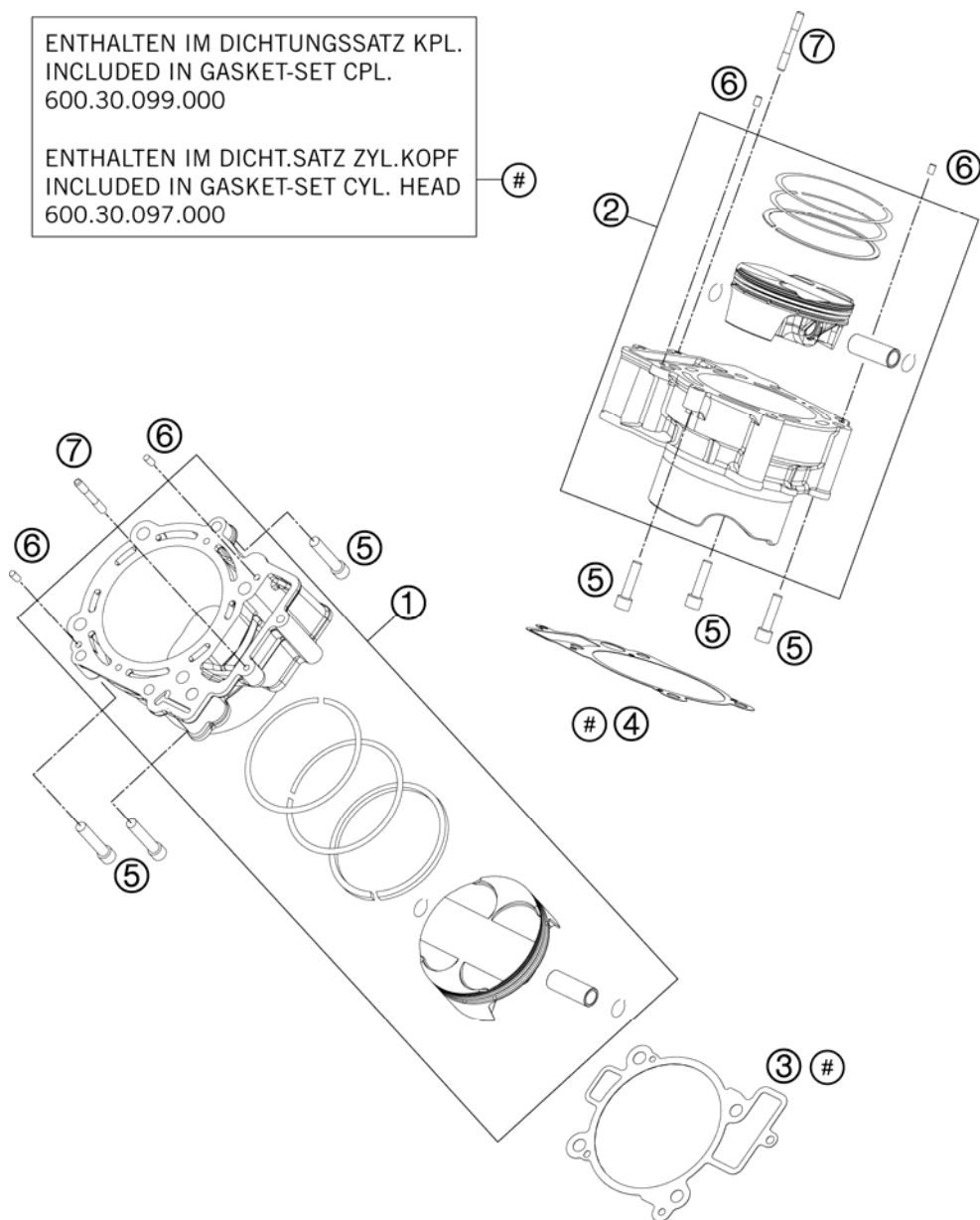

FIG	PART NUMBER	DESCRIPTION	QTY
1	6103003810023	CYLINDER + PISTON CPL. FRONT	1
2	6103013810023	CYLINDER + PISTON CPL. REAR	1
3	60030035000	CYLINDER-BASE GASKET FR 0,35MM	1
4	60030135000	CYLINDER-BASE GASKET RR 0,35MM	1
5	0912080353	AH SCREW DIN0912-M 8X35	6
6	0474050100	GROOVED PIN DIN1474 5X10	4
7	60030043020	STUD M6X47 03	2

116213040 / C116213040

\* NEW PART

X AS REQUIRED

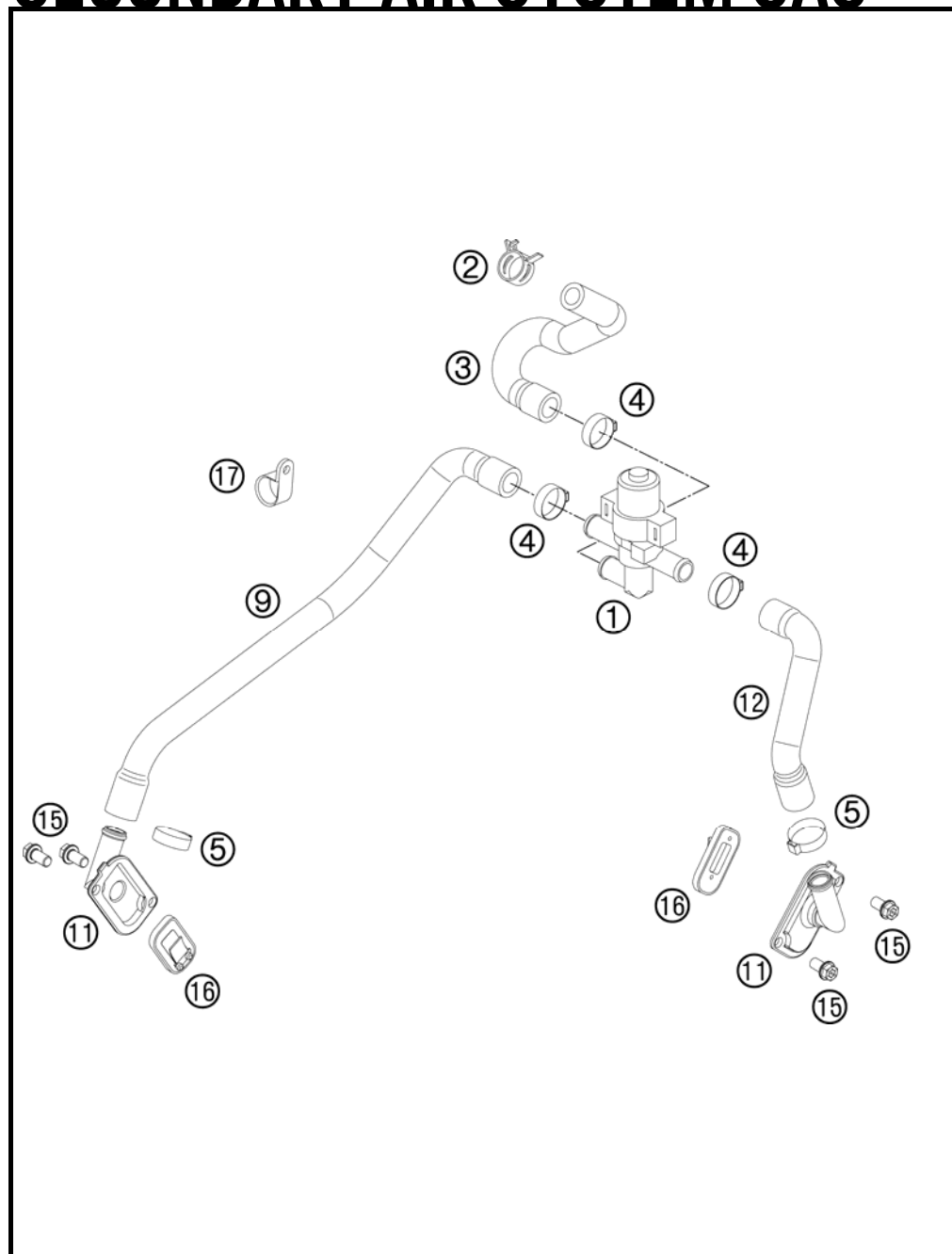

FIG	PART NUMBER	DESCRIPTION	QTY
1	61005026000	CONTROL VALVE SAS	05
2	00049190121	CLAMP STD DN19	1
3	61005035023	SAS HOSE AIRBOX	05
4	00050226706	VARIABLE ONE-EAR CLAMP 22,6MM	3
5	00050210706	VARIABLE ONE-EAR CLAMP 21,0MM	2
9	61005035021	SAS HOSE CYLINDER FRONT	05
11	60005022000	SAS FLANGE	03
12	61005035022	SAS HOSE CYLINDER REAR	05
15	0025060126	HH COLLAR SCREW M6X12 TX30	4
16	60005026000	SLS-VALVE	03
17	57013070400	PVC CLAMP 17,4MM HEYCO 3381	1

116113130 / C116113130

\* NEW PART

X AS REQUIRED

# CLUTCH

# 990 SUPERDUKE 2012

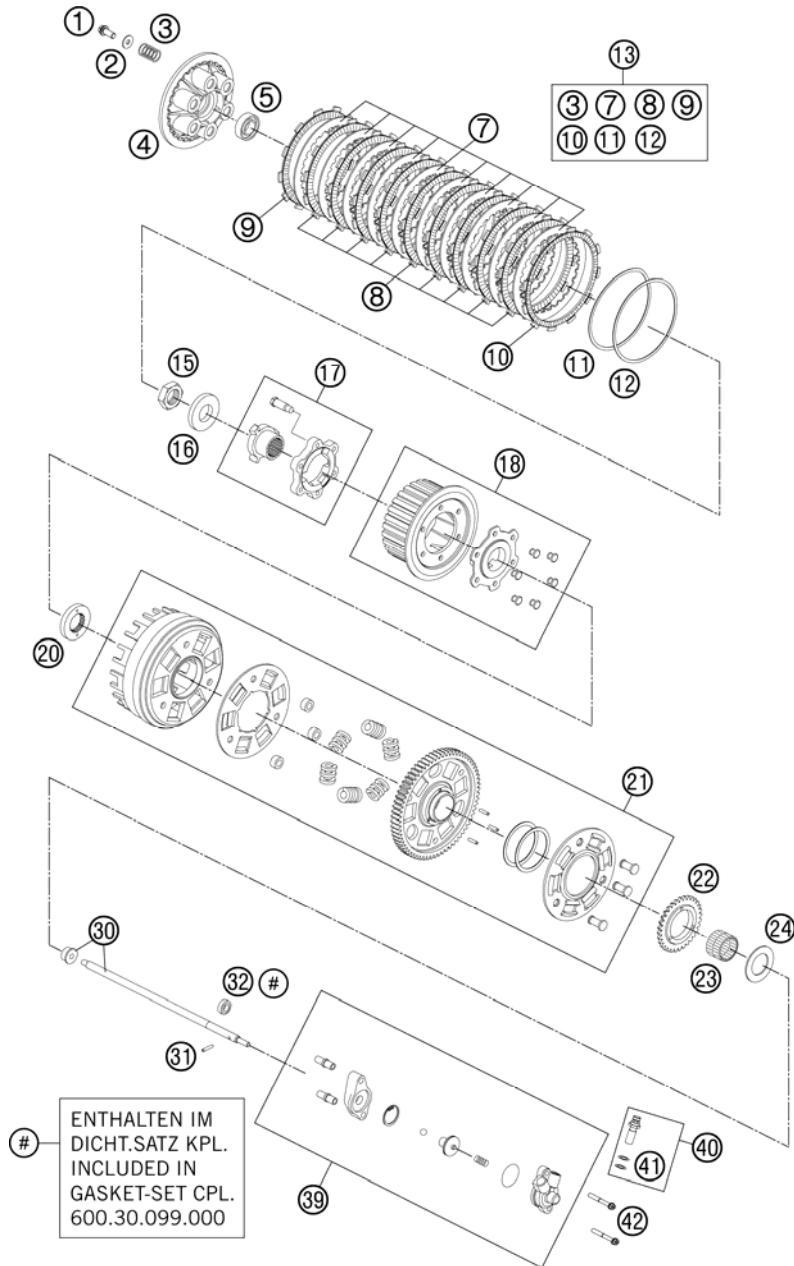

FIG	PART NUMBER	DESCRIPTION	QTY
1	0025060166	HH COLLAR SCREW M6X16 TX30	6
2	0021060003	WASHER DIN9021-A 6,4	6
3	60032005000	CLUTCH SPRING LC8 2003	6
4	60032003000	PRESSURE CAP LC8 2003	1
5	0625060032	BALL BEARING 6003 JR2 C4	1
7	60032010000	STEEL DISC 2MM	10
8	60032011000	LINING DISK 2,8MM	9
9	60032111000	LINING DISK OUTSIDE 2,8MM	03
10	60032012000	LINING DISK TURN OUT 2,8MM	03
11	60032034000	BELLEVILLE SPRING 2003	1
12	60032035000	THRUST WASHER 2003	1
13	60032011010	CLUTCH KIT LC8 03-11	1
15	0936220155	HEXAGON NUT DIN0936-M22X1,5 R.	1
16	0126220373	% WASHER DIN0126 22X37X3 MM	1
17	60032080000	CLUTCH BOOSTER UNIT CPL. 03	1
18	60032002000	INNER CLUTCH HUB CPL. 03	1
20	60032021000	SECTION WASHER 03	1
21	60032001144	OUT.CLUTCH HUB CPL. 67-T 2004	1
22	60038001132	OIL PUMP GEAR WHEEL 32-T 07	1
23	0618303526	NEEDLE BUSH HK 30X35X26	1
24	60032020000	STOP DISK 30,2/50/2	1
30	60032054400	PUSH ROD CPL.	1
31	0402031780	NEEDLE ROL.DIN5402 NRB 3X17,8	1
32	0760091862	SHAFT SEAL RING 9X18X06 B-NBR	1
39	60032061244	CYLINDER CPL. LC8 08	1
40	50332062000	HOLLOW SCREW CPL. M 10X1 '98	1
41	0603100141	COPPER GASKET DIN7603-10X14X1	2
42	0025060506	HH COLLAR SCREW M6X50 TX30	2

116113210 / C116113210

\* NEW PART

X AS REQUIRED

# TRANSMISSION I - MAIN SHAFT

990 SUPERDUKE 2012

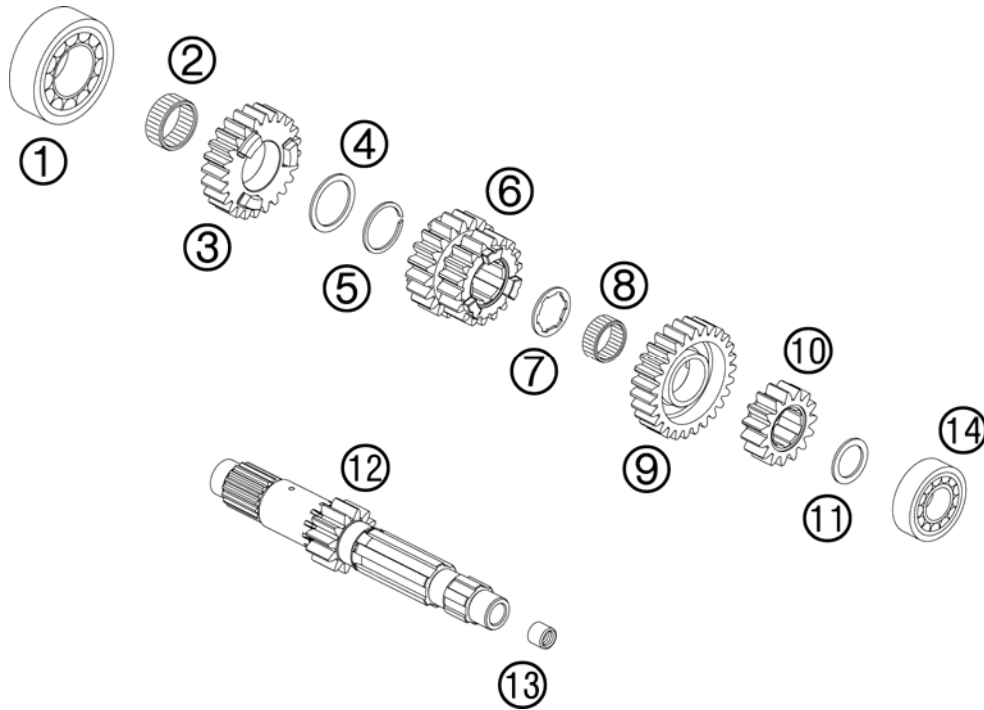

FIG	PART NUMBER	DESCRIPTION	QTY
1	0625062062	BALL BEARING 6206 C3 J1 NSK	1
2	0405263113	NEEDLE BEAR. K 26-31-13	1
3	61033005000	IDLER 5. GEAR 05	1
4	60033042000	STOP DISK 28,3/35,75/1,5	1
5	0417280150	LOCK RING DIN5417-WS28	1
6	61033003000	SLIDING GEAR 3/4 GEAR 05	1
7	60033041000	STOP DISK 22,2/30,2/1,5	1
8	0405222613	NEEDLE BEAR. K 22X26X13 TN	1
9	61033006000	IDLER 6. GEAR 05	1
10	61033002100	2ND GEAR MAINSHAFT 610 2P16-1	1
11	60033040015	STOP DISK 20,2X28X1,5	x
11	60033040016	STOP DISK 20,2/28/1,6	x
11	60033040017	STOP DISK 20,2/28/1,7	x
11	60033040018	STOP DISK 20,2/28/1,8	x
11	60033040019	STOP DISK 20,2/28/1,9	x
11	60033040020	STOP DISK 20,2/28/2,0	x
11	60033040021	STOP DISK 20,2/28/2,1	x
11	60033040022	STOP DISK 20,2/28/2,2	x
12	61033001000	MAIN SHAFT 05	1
13	0618091312	NEEDLE BUSH HK0912 9/13/12 03	1
14	0625062040	BALL BEARING 6204 DU J1 C3	1

116113330 / C116113330

\* NEW PART

X AS REQUIRED

# TRANSMISSION II - COUNTERSHAFT

990 SUPERDUKE 2012

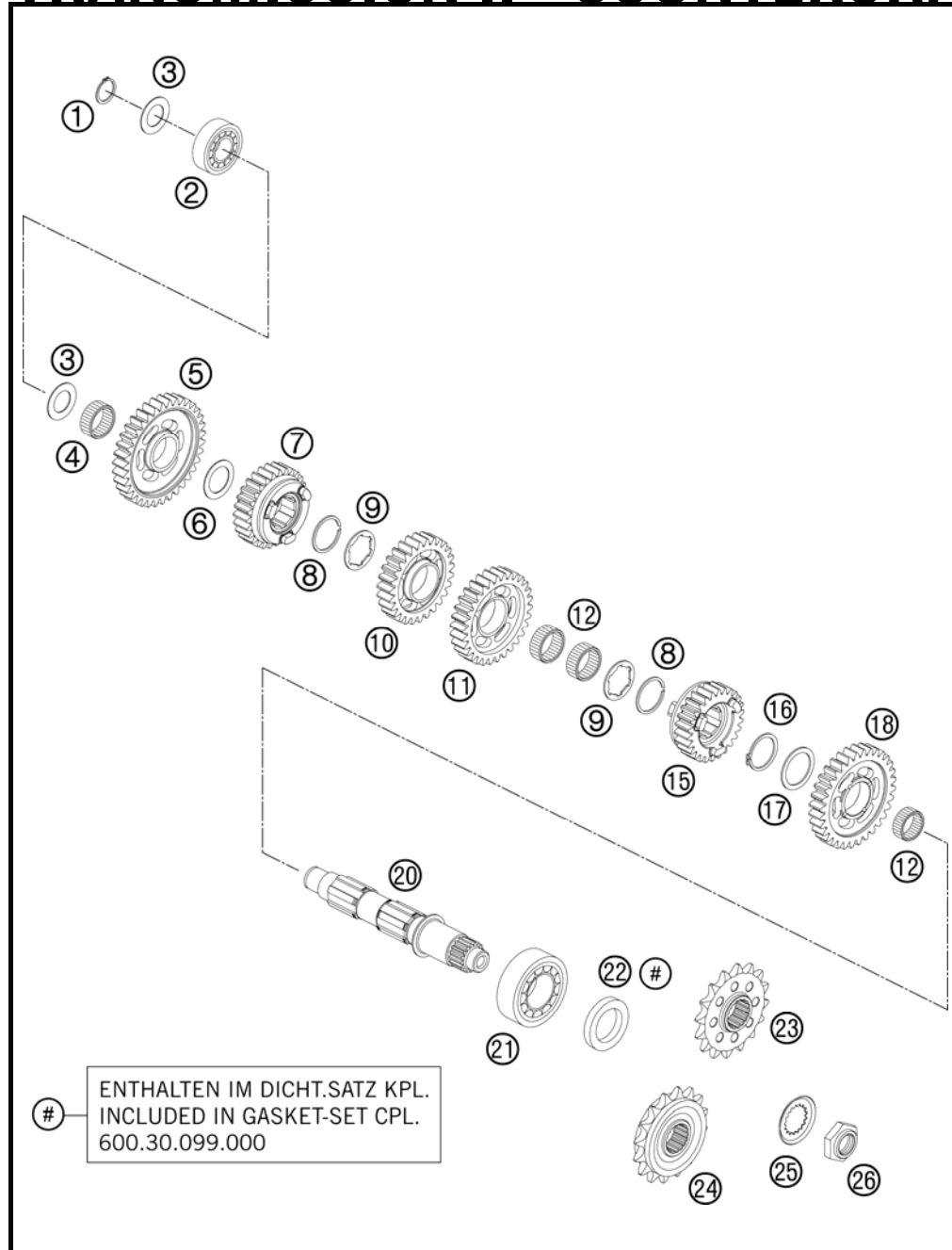

FIG	PART NUMBER	DESCRIPTION	QTY
1	0471200120	CIRCLIP DIN471 20X1,2	1
2	0625062040	BALL BEARING 6204 DU J1 C3	1
3	60033043000	STOP DISK 20,2 X 34 X 1	2
4	0405242813	NEEDLE BEAR. K 24X28X13 TN	1
5	61033011000	IDLER 1. GEAR 05	1
6	60033044000	STOP DISK 24,3/35,75/1	1
7	61033015000	5TH GEAR MAINSHAFT 05	1
8	0417300151	LOCK RING WS 30	2
9	60033045000	STOP DISK 26,2/36/1,5	2
10	61033014000	IDLER GEAR 4TH G 05	1
11	61033013000	IDLER 3. GEAR 05	1
12	0405263113	NEEDLE BEAR. K 26-31-13	3
15	61033016000	6th gear mainshaft 05	1
16	0471300151	CIRCLIP DIN0471-30X1,5 NIRO	1
17	60033046000	STOP DISK 30,2/39/1,5	1
18	61033012000	IDLER 2. GEAR 05	1
20	60033010000	COUNTERSHAFT 03	1
21	50330082000	CYL.ROLLER BEAR.NJ206 ET2XCS46	1
22	0760304772	SH.SEAL RING 30X47X7 BSL VITON	1
23	60033029017	CHAIN SPROCKET 17-T 03	x
24	60033129016	CHAIN SPROCKET 16-T DAMP 03	1
24	60033129017	CHAIN SPROCKET 17-T DAMPED 03	x
25	60033034000	SECURING PLATE TOOTHED 03	1
26	60033035000	HEXAGON NUT M20X1,5 03	1

116113360 / C116113360

\* NEW PART

X AS REQUIRED



# SHIFTING MECHANISM

990 SUPERDUKE 2012

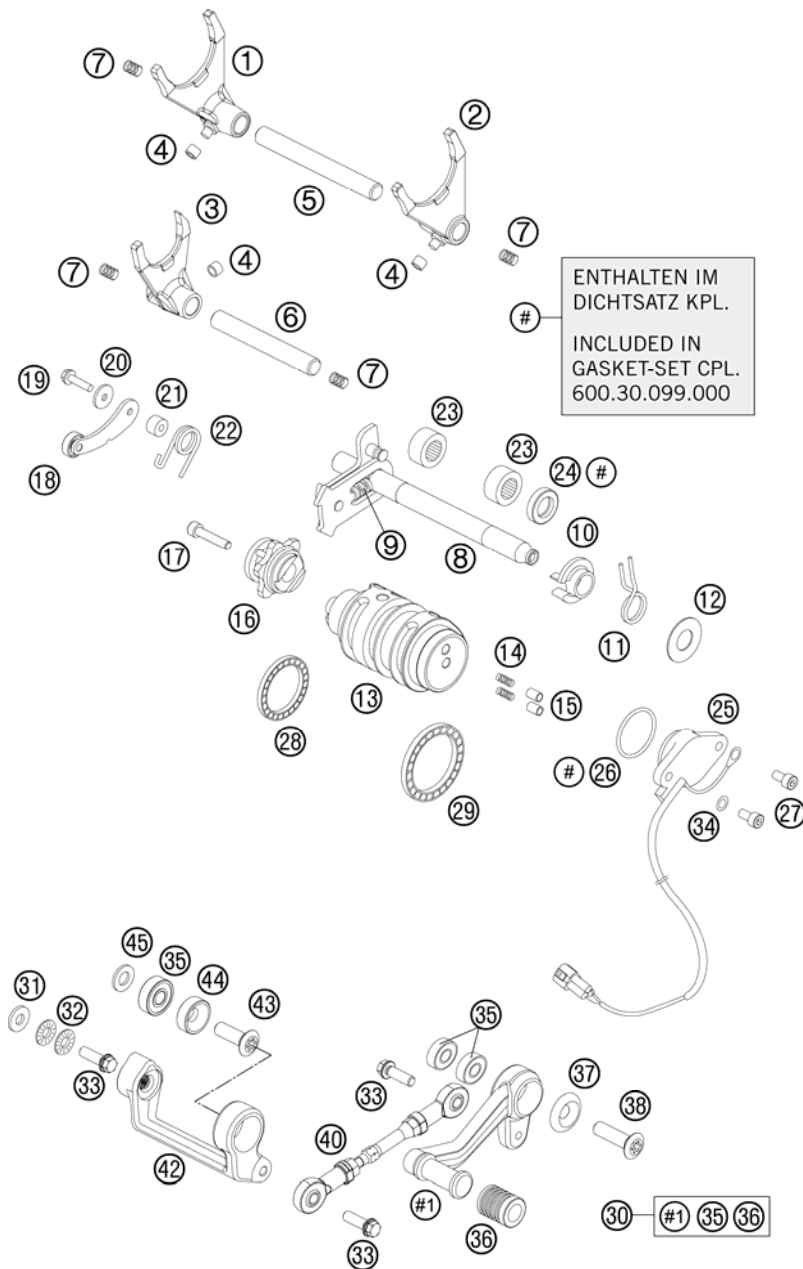

FIG	PART NUMBER	DESCRIPTION	QTY
1	60034001100	SHIFT FORK 1-4 GEAR	1
2	60034002100	SHIFT FORK 2-3 GEAR	1
3	60034003100	SHIFT FORK 5-6 GEAR	1
4	50334018100	SHIFTING ROLLER 6X8X5,2	3
5	59034020000	SHIFT RAIL 11,8X105MM	1
6	59034019000	SHIFT RAIL 11,8X89MM	1
7	58038023200	PRESSURE SPRING 0,9MM	4
8*	60034105044	SHIFT SHAFT CPL.	1
9*	56534113100	TENSIONING SPRING 0,8MM	1
10*	54634120000	SPRING GUIDE	1
11	54634014100	RETURN SPRING 2,2MM '95	1
12	54634050000	STOP DISK 14X30X1	1
13	60034012300	SHIFT ROLLER CPL.	06
14	60034014000	CONTACT SPRING	03
15	60034037000	CONTACT BOLT	03
16	60034015044	SHIFT ARRESTING CPL.	03
17	0912060303	AH SCREW DIN0912-M 6X30	1
18	60034024044	ARRESTING LEVER CPL.	03
19	0025050206	HH COLLAR SCREW M5X20 TX30	1
20	0349000050	WASHER DIN7349-5X15X2	1
21	54634052300	SLEEVE FOR LOCKING LEVER	1
22	60034023000	ARRESTING LEVER SPRING	03
23	54632095000	NEEDLE BEAR.HK 1412 14X20X12	2
24	0760142460	SHAFT SEAL RING 14X24X6 B	1
25	60011023100	GEAR-POSITION SENSOR	06
26	0770275025	O-RING 27,5X2,5 NBR	1
27	0912050123	AH SCREW DIN0912-M 5X12	2
28	0625618050	BALL BEARING 61805 C3	1
29	0625068080	GROOVED BALL BEARING 6808 JRC3	1
30	6103403104433S	SHIFT LEVER CPL. BLACK	07
31	50232050001	STEEL WASHER 6,4X17X3	1
32	50233041000	PAIR OF WASHERS M 6 NORDLOCK	1
33	59009062019	SPECIAL SCREW M6X19 WS=8 10.9	3
34	0125050003	WASHER DIN0125-A 5,3	1
35	0625006087	GROOVED BALL BEAR. 608 2RS C3	3

116113410 / C126113410

\* NEW PART

X AS REQUIRED



# SHIFTING MECHANISM

990 SUPERDUKE 2012

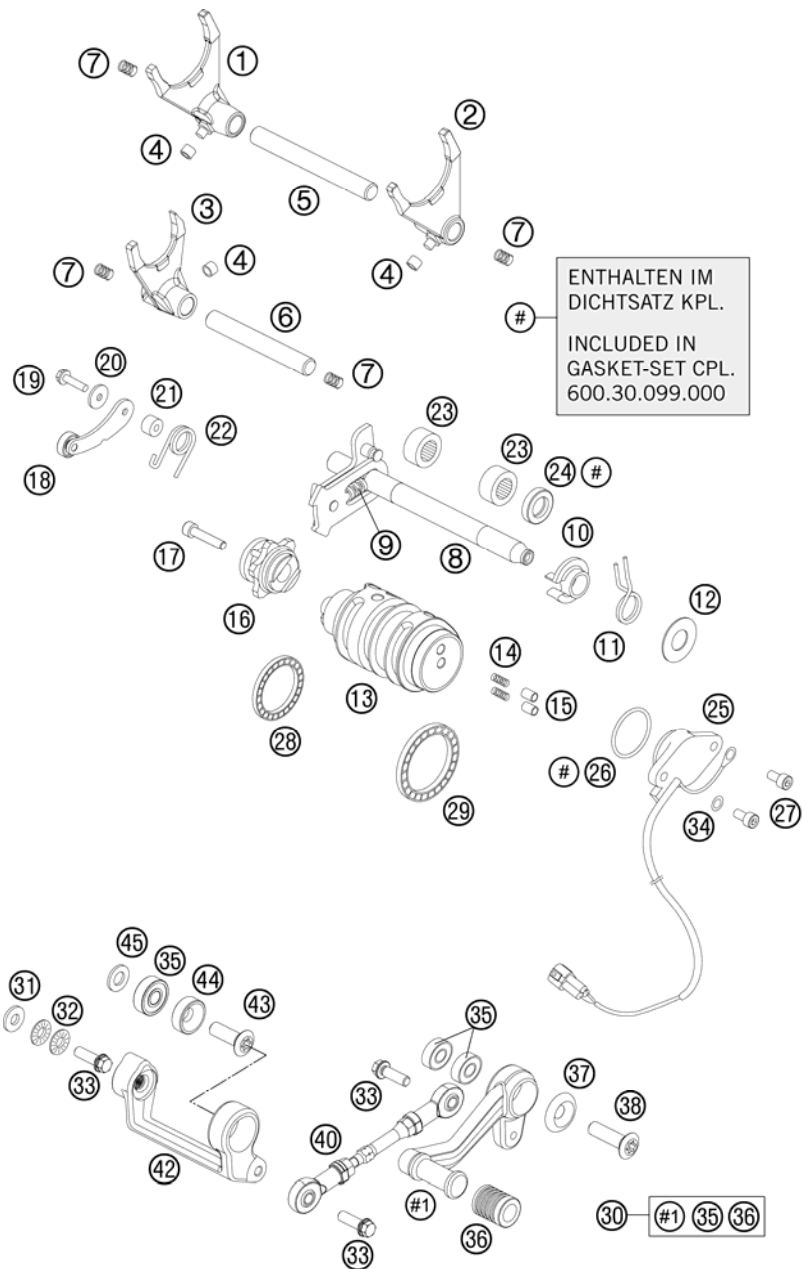

FIG	PART NUMBER	DESCRIPTION	QTY
36	61034035000	RUBBER FOR SHIFT LEVER 05	1
37	58303061200	SPECIAL WASHER ALU 8X24 MM	1
38	0019080306S	COUNTER-SUNK SCREW ISA45 M8X30	1
40	69034036044	SHIFT ROD CPL.	1
42	6103403000033S	RELAY LEVER BLACK 07	1
43	0019080266S	COUNTER-SUNK SCREW ISA45 M8X26	1
44	61034030050	WASHER COUNT. 8,5X21X7,804	1
45	0125080003	WASHER DIN0125-A 8,4	1

116113410 / C126113410

\* NEW PART

X AS REQUIRED

# WATER PUMP

990 SUPERDUKE 2012

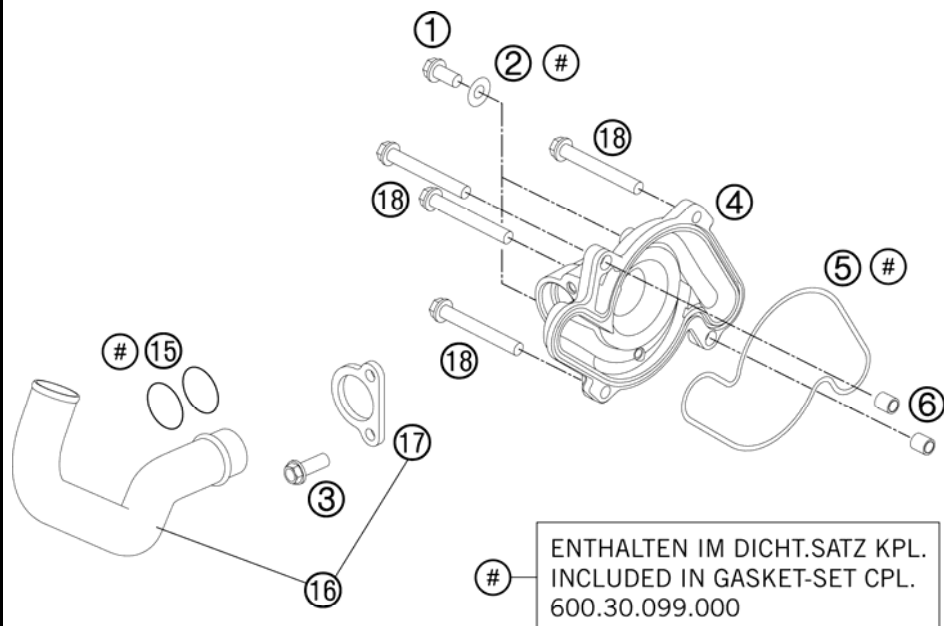
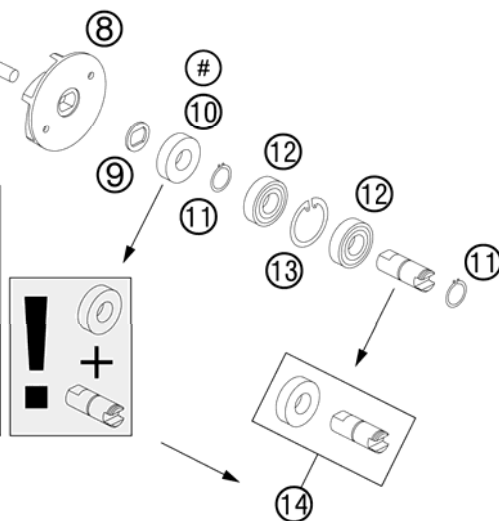

FIG	PART NUMBER	DESCRIPTION	QTY
1	0025060106	HH COLLAR SCREW M6X10 TX30	2
2	0603061001	CU-SEAL RING DIN7603-6X10X1	2
3	0025060166	HH COLLAR SCREW M6X16 TX30	2
4	6003505210023	WATERPUMP COVER	1
5	60035053000	WATER-PUMP GASKET 03	1
6	59030023000	DOWEL 6X8X11,5	2
7	0024060156	HH COLLAR SCREW M6X15 TX30	1
8	60035055100	WATER-PUMP WHEEL LC8 03	1
9	60035055150	FORM WASHER 16X1 NIRO 03	1
10	0760123073	SHAFT SEAL RING 12X30X7 PTFE DOUBLE-LIP	1
11	0471120010	CIRCLIP DIN0471-12X1	2
12	0625069010	GROOVED BALL BEARING 6901V C3	2
13	0472240120	CIRCLIP DIN472 D=24X1,2	1
14	60035054144	WATER PUMP SHAFT W/ SEAL RING INCL. SHAFT SEAL RING	1
15	0770250030	O-RING 25,00X3,00 NBR 70	2
16	60035021000	ALUMINUM TUBE WATER-PUMP+CLAMP	1
17	60035021050	FIXING CLAMP WATER-P. TUBE 03	1
18	0025060606	HH COLLAR SCREW M6X60 TX30	4

**ACHTUNG !!!**  
Mit dem Wellendichtring auch die Wasserpumpenwelle wechseln.

**CAUTION !!!**  
With the shaft seal ring also change the water-pump shaft.



116113510 / C116113510

\* NEW PART

X AS REQUIRED

# COOLING SYSTEM

990 SUPERDUKE 2012

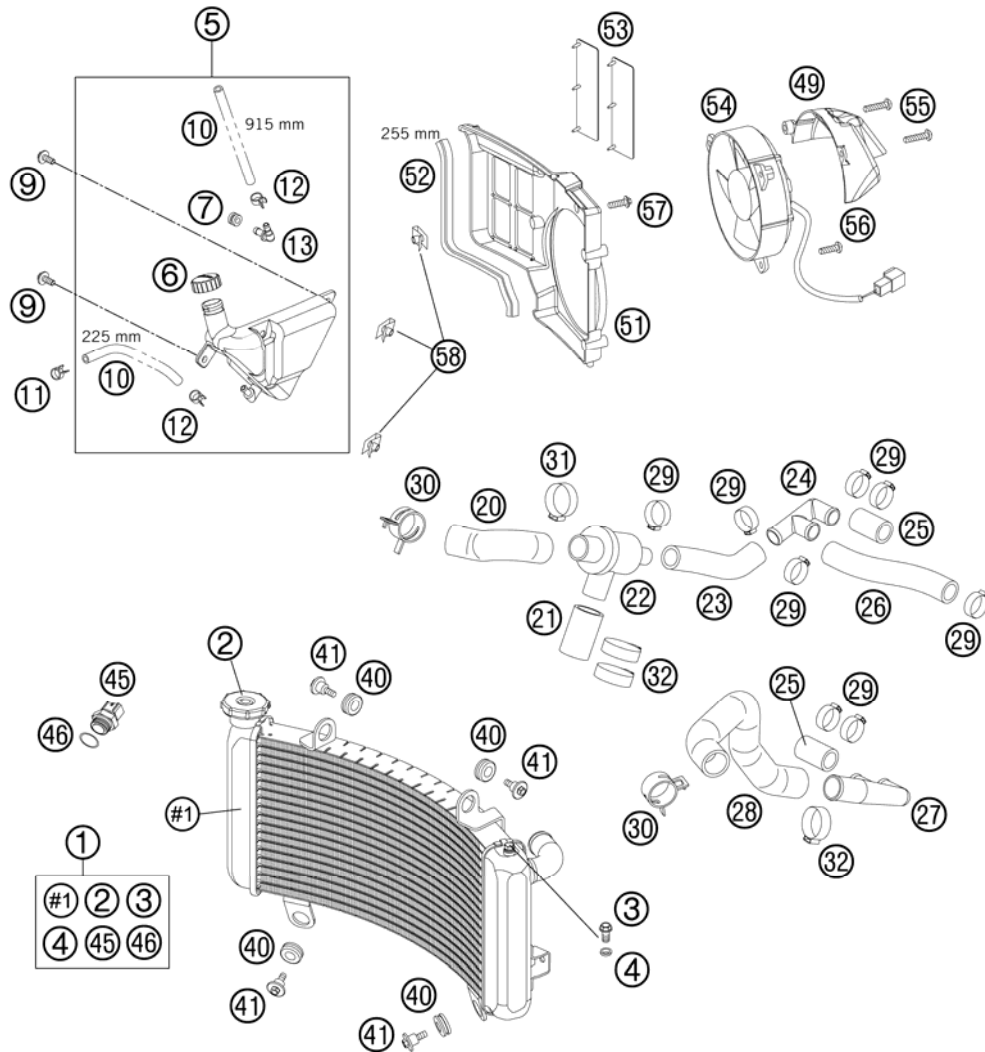

FIG	PART NUMBER	DESCRIPTION	QTY
1	61035110000	RADIATOR 990 DUKE 09	1
2	61035016000	RADIATOR CAP 990 DUKE 05	1
3	0025060106	HH COLLAR SCREW M6X10 TX30	1
4	60035048000	ALU-GASKET 6X10X1.5	1
5	61035065000	EXPANSION TANK CPL. 05	1
6	60035066000	PLUG F. EXPANSION TANK	1
7	58214069051	RUBBER GROMMET 16X10,8X3 02	1
9	0024060156	HH COLLAR SCREW M6X15 TX30	2
10	60035067001	HOSE 6X10 EPDM 03	x
11	50231005000	HOSE CLAMP YDNAC 10119 11MM	1
12	58007117000	YDNAC-CLAMP 10107 10MM	2
13	60035068000	ANGLE CONNECTION EXPANS. TANK	1
20	60035031000	RADIATOR HOSE THERM./RAD.	1
21	60035030000	RADIATOR HOSE THERM./PUMP 03	1
22	60035017000	THERMOSTAT 75° CPL. W. CASE 03	1
23	60035025000	RADIATOR HOSE THERM./DISTR. 03	1
24	60035019000	DISTRIBUTOR R/S 18/18/18MM 03	1
25	60035026000	RADIATOR HOSE CYL./DISTR. 03	2
26	60035027000	RADIATOR HOSE DISTR./DISTR. 03	1
27	60035028000	DISTRIBUTOR L/S 18/18/25MM 03	1
28	60035024000	RADIATOR HOSE RADIATOR L/S 03	1
29	00050271708	VARIABLE ONE-EAR CLAMP 27,1MM	8
30	00049320121	CLAMP STD DN32	2
31	00050346706	VARIABLE ONE-EAR CLAMP 34,6MM	1
32	00050331706	VARIABLE ONE-EAR CLAMP 33,1MM	3
40	41001052000	RUBBER SLEEVE D=12MM	4
41	60035001000	SPECIAL SCREW M6X21 WS=8	4
45	60035045000	THERMOSWITCH LC8 102DG '03	1
46	0770017015	O-RING 17X1,5 NB75	1
49	61035044050	FAN CAP 05	1
51	60035044000	FAN COWL L/S 03	1
52	58312085100	EDGE PROTECTOR PER METER	x
53	62635044050	FAN CLACK RUBBER 08	2
54	60035041000	FAN L/S 03	1
55	0017060303	SPECIAL SCREW T60 6X30 WS=6	2

116113530 / C116113530

\* NEW PART

X AS REQUIRED

# COOLING SYSTEM

990 SUPERDUKE 2012

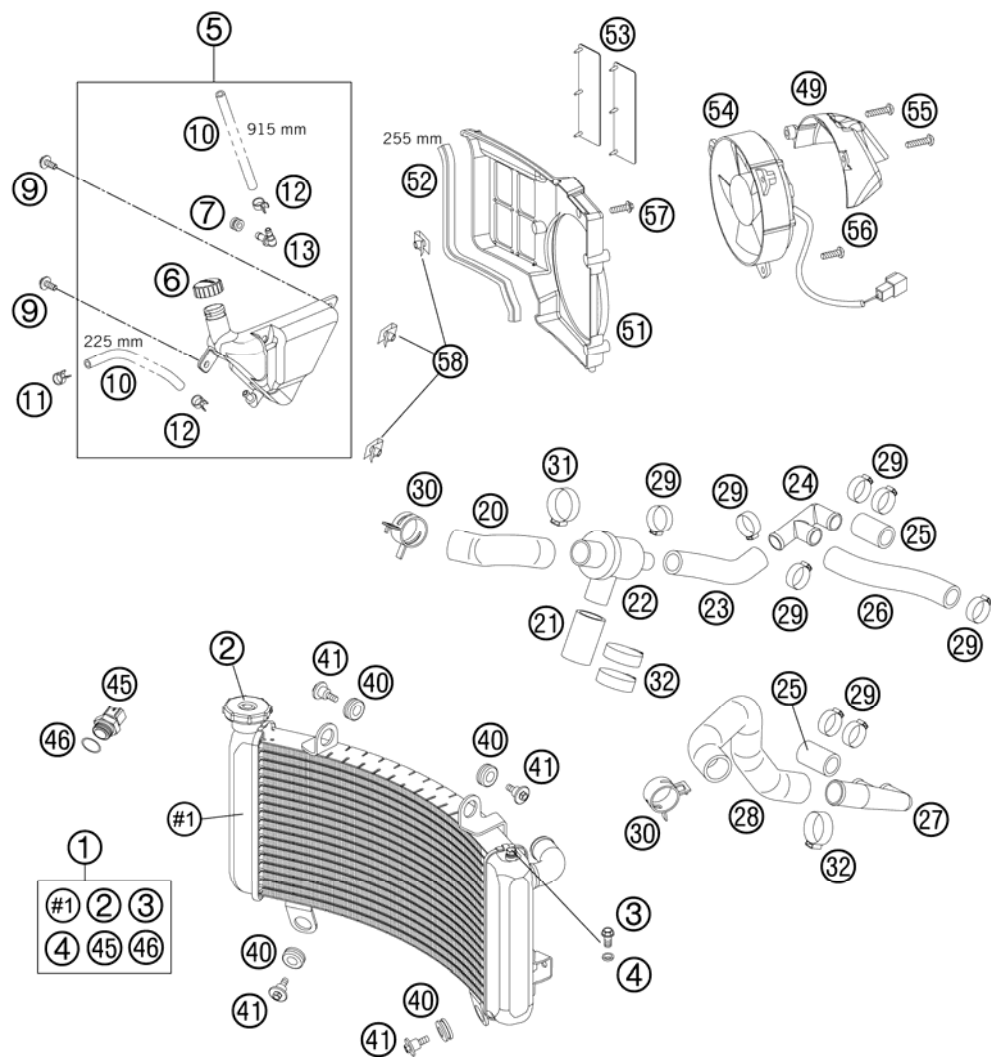

FIG	PART NUMBER	DESCRIPTION	QTY
56	0017060203	EJOT PT SCREW K60X20 WS=6	1
57	0024060206	HH COLLAR SCREW M6X20 TX30	1
58	54603048100	RANGE CHANGE METAL NUT M6	3

116113530 / C116113530

\* NEW PART

X AS REQUIRED

EXHAUST

INTAKE

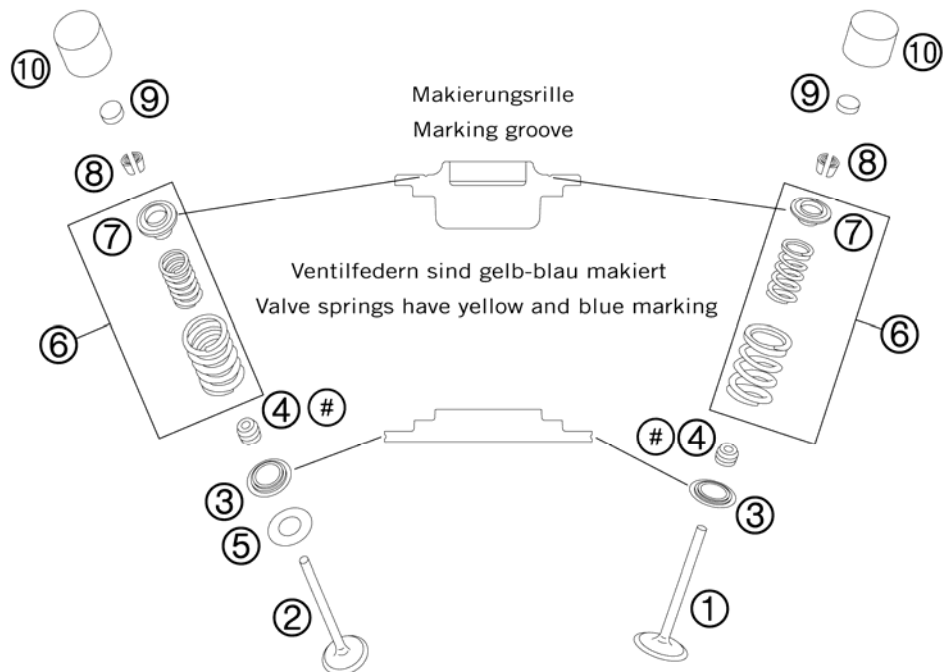

FIG	PART NUMBER	DESCRIPTION	QTY
1	60036030000	INTAKE VALVE 03	4
2	60036031100	EXHAUST VALVE 05	4
3	61036036000	VALVE SPRING HOLDER 05	8
4	59036027000	VALVE-STEM SEALING RACING	8
5	54634050000	STOP DISK 14X30X1 EXHAUST	4
6	61036029044	VALVE SPRING SET CPL. 05	8
7	61036032000	VALVE SPRING RETAINER STEEL 05	8
8	60036033000	VALVE COLLET MK6 03	16
9	60036035200	SHIM D=10/2,00 03	x
9	60036035205	SHIM D=10/2,05 03	x
9	60036035210	SHIM D=10/2,10 03	x
9	60036035215	SHIM D=10/2,15 03	x
9	60036035220	SHIM D=10/2,20 03	x
9	60036035225	SHIM D=10/2,25 03	x
9	60036035230	SHIM D=10/2,30 03	x
9	60036035235	SHIM D=10/2,35 03	x
9	60036035240	SHIM D=10/2,40 03	x
9	60036035245	SHIM D=10/2,45 03	x
9	60036035250	SHIM D=10/2,50 03	x
9	60036035255	SHIM D=10/2,55 03	x
9	60036035260	SHIM D=10/2,60 03	x
9	60036035265	SHIM D=10/2,65 03	x
9	60036035270	SHIM D=10/2,70 03	x
9	60036035275	SHIM D=10/2,75 03	x
9	60036035280	SHIM D=10/2,80 03	x
9	60036035285	SHIM D=10/2,85 03	x
9	60036035290	SHIM D=10/2,90 03	x
9	60036035295	SHIM D=10/2,95 03	x
9	60036035300	SHIM D=10/3,00 03	x
9	60036035305	SHIM D=10/3,05 03	x
9	60036035310	SHIM D=10/3,10 03	x
9	60036035315	SHIM D=10/3,15 03	x
9	60036035320	SHIM D=10/3,20 03	x
10	61036034000	BUCKET TAPPET 05	8

116113610 / C116113610

\* NEW PART

X AS REQUIRED

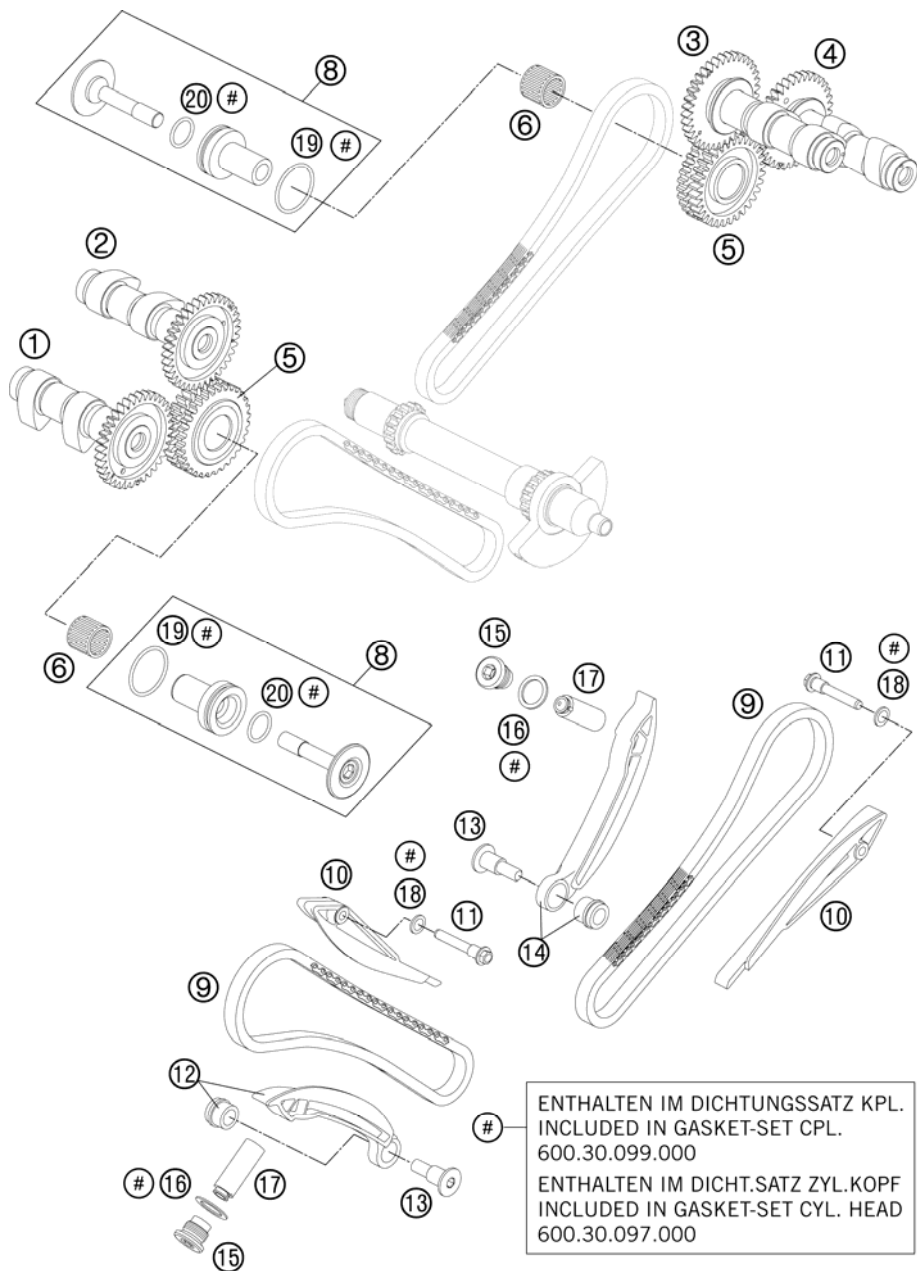

FIG	PART NUMBER	DESCRIPTION	QTY
1	61136010000	CAMSHAFT OUTLET FRONT	1
2	61136009000	CAMSHAFT INTAKE FRONT	1
3	61136109000	CAMSHAFT INTAKE REAR	1
4	61136110000	CAMSHAFT OUTLET REAR	1
5	60036070000	TIMING GEARS 32-T CPL. 03	2
6	0405182420	NEEDLE BEARING K18/24/20	2
8	60036071100	BEARING BOLT	2
9	60036013000	TOOTH CHAIN 88 LINK 6,35PITCH	2
10	60036001000	GUIDE RAIL 03	2
11	60036002160	SPECIAL SCREW M8X29 WS=8	2
12	60036002000	TENSIONER RAIL CPL. FRONT 03	1
13	60036002150	SPECIAL SCREW M8X29 WS=6	2
14	60036102000	TENSIONER RAIL CPL. REAR 03	1
15	60036008000	SCREW PLUG M16X1,5 03	2
16	0603162013	CU SEAL-RING DIN7603 16X20X1,3	2
17	60036003000	TIMING-CH.TENS. HYDR.(75YM) 03	2
18	0603082121	SEAL RING CU DIN7603- 8X12X1	2
19	0770290020	O-RING 29X2 VITON	2
20	0770160021	O-RING 16,00X2,00 VITON	2

ENTHALTEN IM DICHTUNGSSATZ KPL.  
INCLUDED IN GASKET-SET CPL.  
600.30.099.000  
ENTHALTEN IM DICHT.SATZ ZYL.KOPF  
INCLUDED IN GASKET-SET CYL. HEAD  
600.30.097.000

116113620 / C116113620

\* NEW PART

X AS REQUIRED

# CYLINDER HEAD FRONT

990 SUPERDUKE 2012

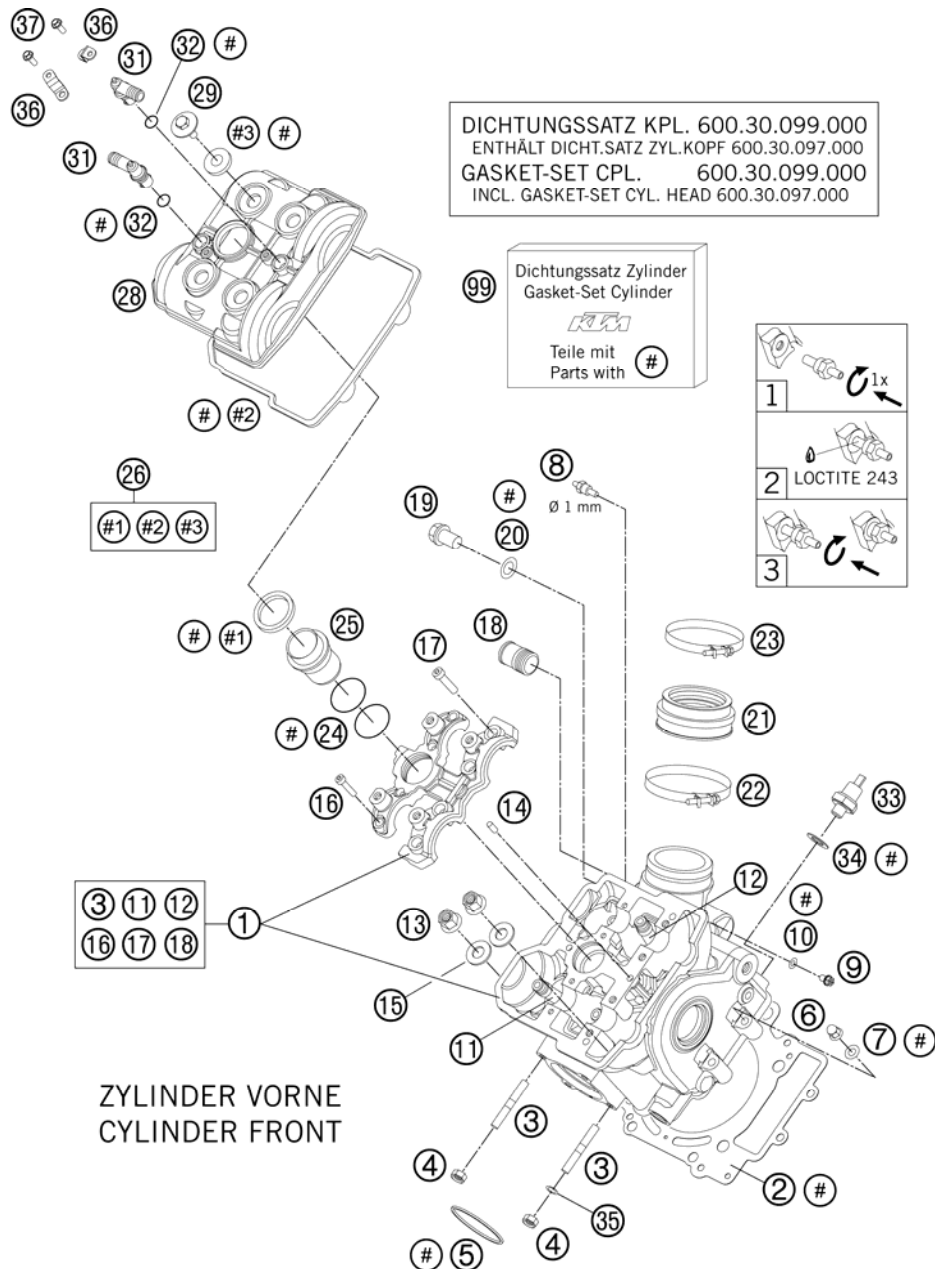

FIG	PART NUMBER	DESCRIPTION	QTY
1	6113602004423	CYLINDER HEAD CPL. FRONT 07	1
2	60030036000	CYLINDER HEAD GASKET 0,5 101MM	1
3	0835080256	STUD DIN0835-M 8X25 10.9	2
4	51010086100	SELF LOCKING NUT M 8 CU	2
5	61005005000	EXHAUST GASKET 05	1
6	61230045000	CAP NUT M6 STAINLESS STEEL	2
7	0125060003	WASHER DIN0125-A 6,4	2
8	61036023100	VACUUM CONNECTION 2006	1
9	0025060106	HH COLLAR SCREW M6X10 TX30	1
10	0603061001	CU-SEAL RING DIN7603-6X10X1	1
11	60036026101	VALVE GIUDE EXHAUST	2
12	60036025101	VALVE GIUDE INTAKE	2
13	60036078200	COLLAR NUT M 10 WS=13 05	4
14	0402050980	NEEDLE ROLLER DIN5402 5X9,8	2
15	60036078050	SHIM 10,2X19X1,5MM 05	4
16	0912060255	AH SCREW DIN0912-M 6X25 10.9	4
17	0984080305	AH SCREW DIN7984-M 8X30 10.9	4
18	58030010200	SCREW IN NOZZLE M20X1,5	1
19	0908120153	PLUG DIN0908-M12X1,5	1
20	58038022000	CU-SEAL RING DIN7603-12X18X1,5	1
21	61036044000	RUBBERSLEEVE INTAKE FLANGE 05	1
22	61036048000	HOSE CLAMP GEMI 66MM 05	1
23	61036047000	HOSE CLAMP GEMI 63MM 05	1
24	0770298178	O-RING 29,87X1,78 VITON	2
25	61136075000	INSERT SPARK-PLUG SHAFT 08	1
26	60036099000	VALVE COVER GASKET SET FR+RR	1
28	6003605210023	VALVE COVER FRONT	1
29	60036052020	COLLAR SCREW M 6 WS=10 03	4
31	60038082000	ANGLE CONNECTOR LC8 03	2
32	0770080020	O-RING 8X2 SILICONE	2
33	60038091100	OIL-PRESSURE SWITCH LC8 04	1
34	0603100141	COPPER GASKET DIN7603-10X14X1	1
35	61005009000	SPACER BUSH. 8,5X15X7,5 05	1
36	60038082050	%ANGLE CONNECTOR BRACKET PANEL	2
37	0009050106	EJOT SPIRAL SCREW SF M5X10-K	2

116113650 / C116113650

\* NEW PART

X AS REQUIRED

# CYLINDER HEAD FRONT

990 SUPERDUKE 2012

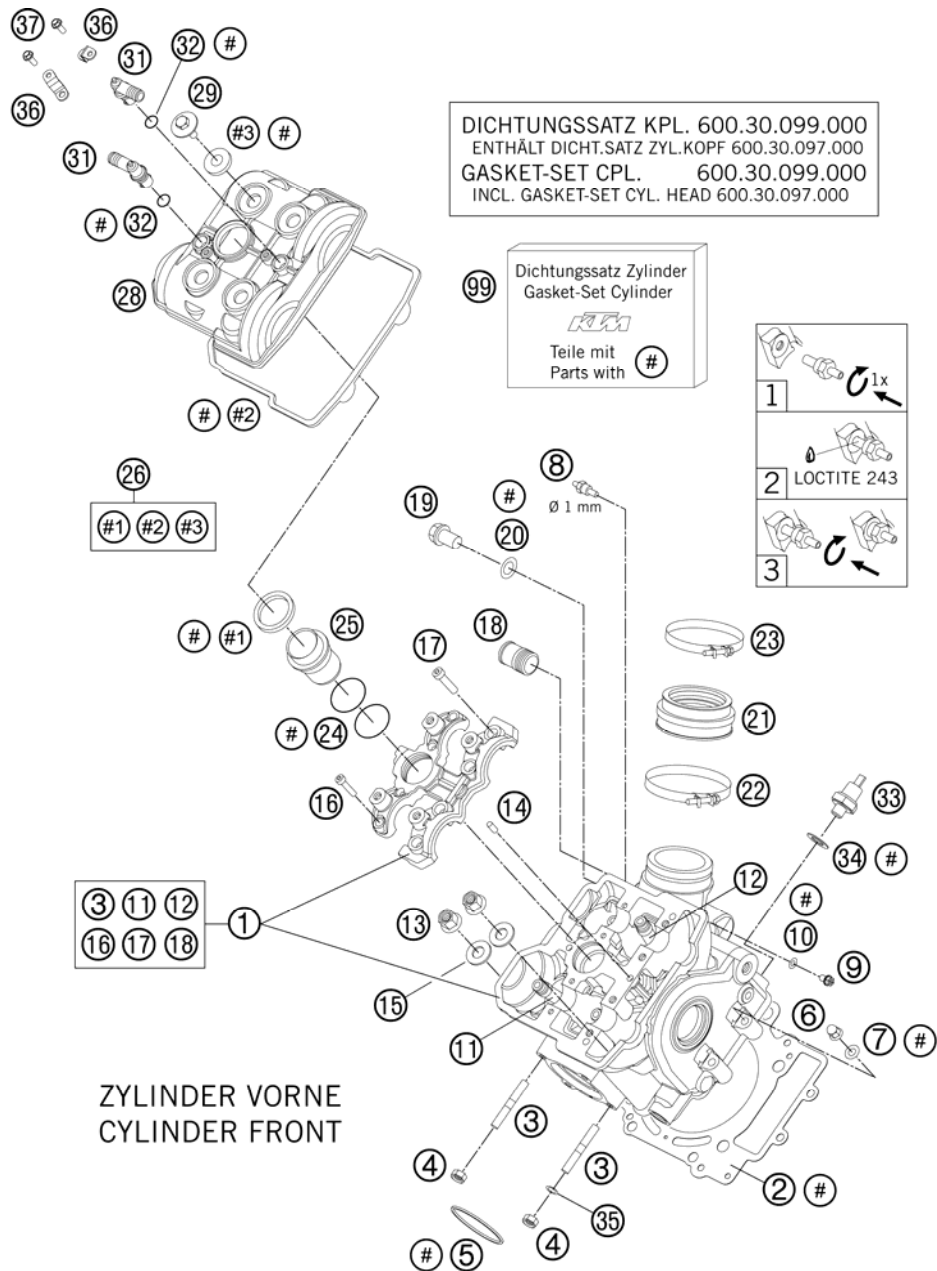

FIG	PART NUMBER	DESCRIPTION	QTY
99	60030097000	GASKET SET CYL. HEAD KPL. 03 CYLINDER FRONT + REAR	1

116113650 / C116113650

\* NEW PART

X AS REQUIRED



# CYLINDER HEAD REAR

990 SUPERDUKE 2012

DICHTUNGSSATZ KPL. 600.30.099.000  
 ENTHÄLT DICHT.SATZ ZYL.KOPF 600.30.097.000  
 GASKET-SET CPL. 600.30.099.000  
 INCL. GASKET-SET CYL. HEAD 600.30.097.000

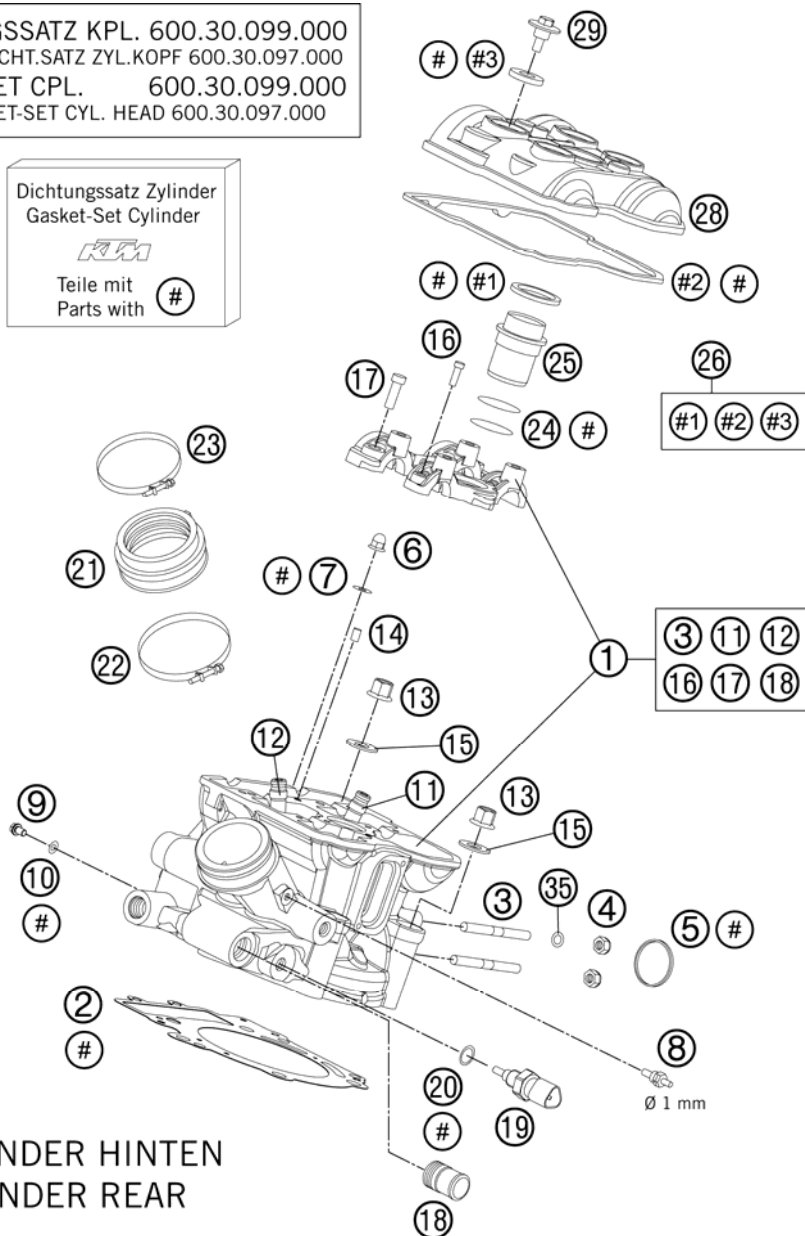

FIG	PART NUMBER	DESCRIPTION	QTY
1*	6203612004423	CYLINDER HEAD REAR CPL.	11
2	60030036000	CYLINDER HEAD GASKET 0,5 101MM	1
3	0835080256	STUD DIN0835-M 8X25 10.9	2
4	51010086100	SELF LOCKING NUT M 8 CU	2
5	61005005000	EXHAUST GASKET	05
6	61230045000	CAP NUT M6 STAINLESS STEEL	2
7	0125060003	WASHER DIN0125-A 6,4	2
8	61036023100	VACUUM CONECTION	2006
9	0025060106	HH COLLAR SCREW M6X10 TX30	1
10	0603061001	CU-SEAL RING DIN7603-6X10X1	1
11	60036026101	VALVE GIUDE EXHAUST	2
12	60036025101	VALVE GIUDE INTAKE	2
13	60036078200	COLLAR NUT M 10 WS=13 05	4
14	0402050980	NEEDLE ROLLER DIN5402 5X9,8	2
15	60036078050	SHIM 10,2X19X1,5MM	05
16	0912060255	AH SCREW DIN0912-M 6X25 10.9	4
17	0984080305	AH SCREW DIN7984-M 8X30 10.9	4
18	58030010200	SCREW IN NOZZLE M20X1,5	1
19	75035047000	TEMPERATURE SENSOR WATER	07
20	0770100020	O-RING 10,00X2,00 SILCONE	1
21	61036044000	RUBBERSLEEVE INTAKE FLANGE	05
22	61036047000	HOSE CLAMP GEMI 63MM	05
23	61036048000	HOSE CLAMP GEMI 66MM	05
24	0770298178	O-RING 29,87X1,78 VITON	2
25*	60136075100	INSERT SPARK-PLUG SHAFT	1
26	60036099000	VALVE COVER GASKET SET FR+RR	1
28	6003615210023	VALVE COVER REAR	1
29	60036052020	COLLAR SCREW M 6 WS=10	03
35	61005009000	SPACER BUSH. 8,5X15X7,5	05
99	60030097000	GASKET SET CYL. HEAD KPL. CYLINDER FRONT + REAR	03

116213640 / C116213640

\* NEW PART

X AS REQUIRED

# LUBRICATING SYSTEM

990 SUPERDUKE 2012

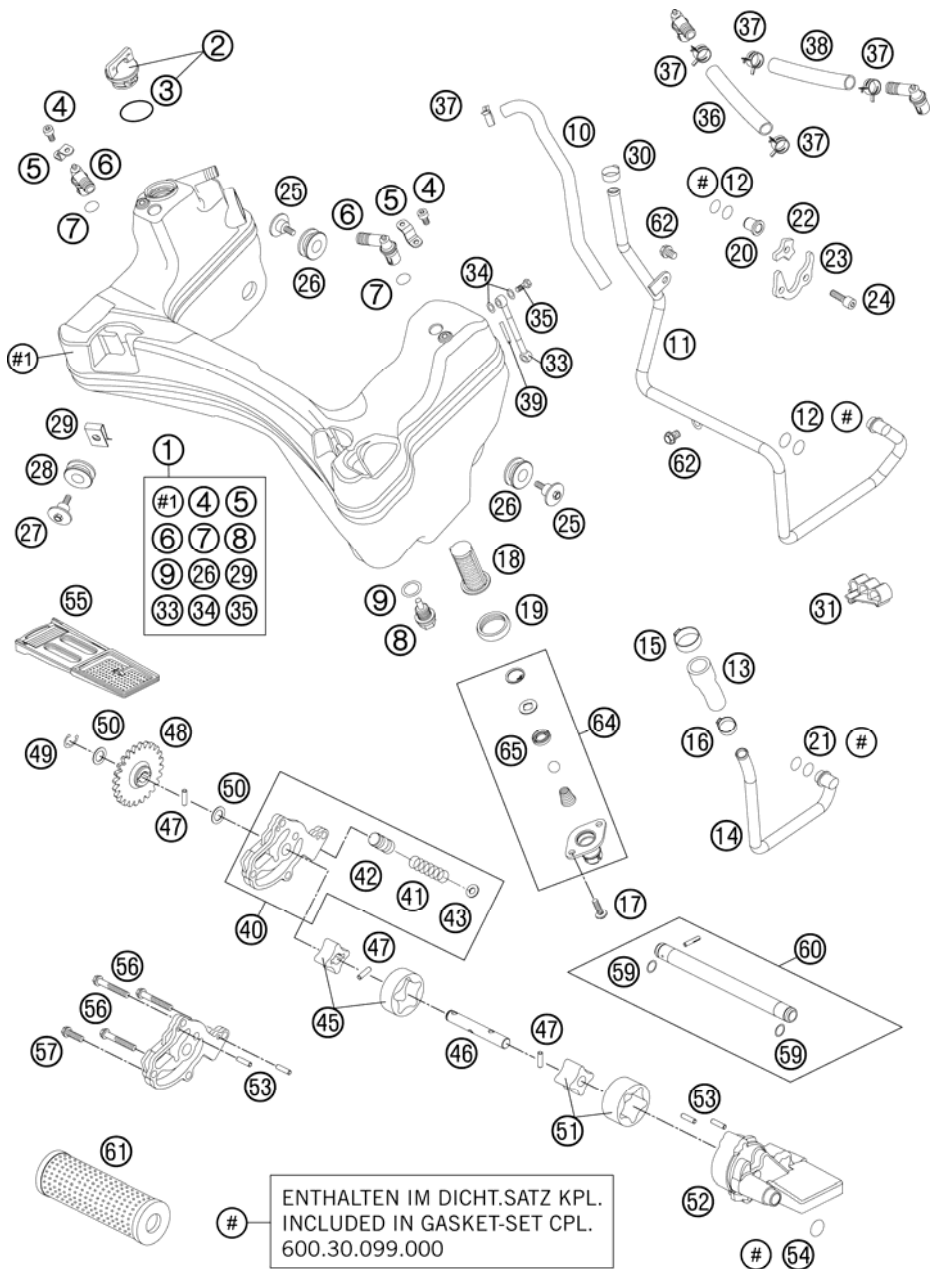

FIG	PART NUMBER	DESCRIPTION	QTY
1	61038081233	OIL TANK CPL.	1
2	58030020100	PLUG CPL. M24X3	1
3	0770191015	O-RING 19,00X3,00 NBR	1
4	0912050103	AH SCREW DIN0912-M 5X10	2
5	69006015050	BRACKET F. EFI-PLUG	2
6	60038082000	ANGLE CONNECTOR LC8 03	2
7	0770080020	O-RING 8X2 SILICONE	2
8	58030021000	OILDRAIN PLUG W.MAG. M 12X1,5	1
9	58038022000	CU-SEAL RING DIN7603-12X18X1,5	1
10	60038061203	PREFORMED HOSE D9X3,5	1
11	60038061044	OIL PIPE "B"	1
12	0770090021	O-RING 9X2 VITON	4
13	61038034000	OIL HOSE PIPE A 05	1
14	60038060044	OIL PIPE "A"	1
15	00050226706	VARIABLE ONE-EAR CLAMP 22,6MM	1
16	00050198706	VARIABLE ONE-EAR CLAMP 19,8MM	1
17	0025060166	HH COLLAR SCREW M6X16 TX30	2
18	60038017000	OIL SCREEN FINISHED 03	1
19	60038018000	GASKET FOR OIL FILTER HNBR 03	1
20	60038024000	PLUG 10MM LC8 03	1
21	0770110021	O-RING 11X2 VITON	2
22	60038037000	RETAINING PLATE 2 LC8 03	1
23	60038036000	RETAINING PLATE 1 LC8 03	1
24	0912060203	AH SCREW DIN0912-M 6X20	3
25	60038083000	SCREW OIL TANK FIXING 03	3
26	54605068000	EXHAUST BRACKET RUBBER BLACK	3
27	60035001000	SPECIAL SCREW M6X21 WS=8	2
28	41001052000	RUBBER SLEEVE D=12MM	2
29	54603048100	RANGE CHANGE METAL NUT M6	2
30	00050185706	VARIABLE ONE-EAR CLAMP 18,5MM	1
31	61011093000	WIRING HOLDER 05	x
33	61038084100	OIL RISING PIPE CPL.	1
34	0603082121	SEAL RING CU DIN7603- 8X12X1	4
35	58038029000	BANJO BOLT M8X1	2
36	60038059130	OIL TANK BREATHING HOSE R/S	1

116113810 / C126113810

\* NEW PART

X AS REQUIRED

# LUBRICATING SYSTEM

990 SUPERDUKE 2012

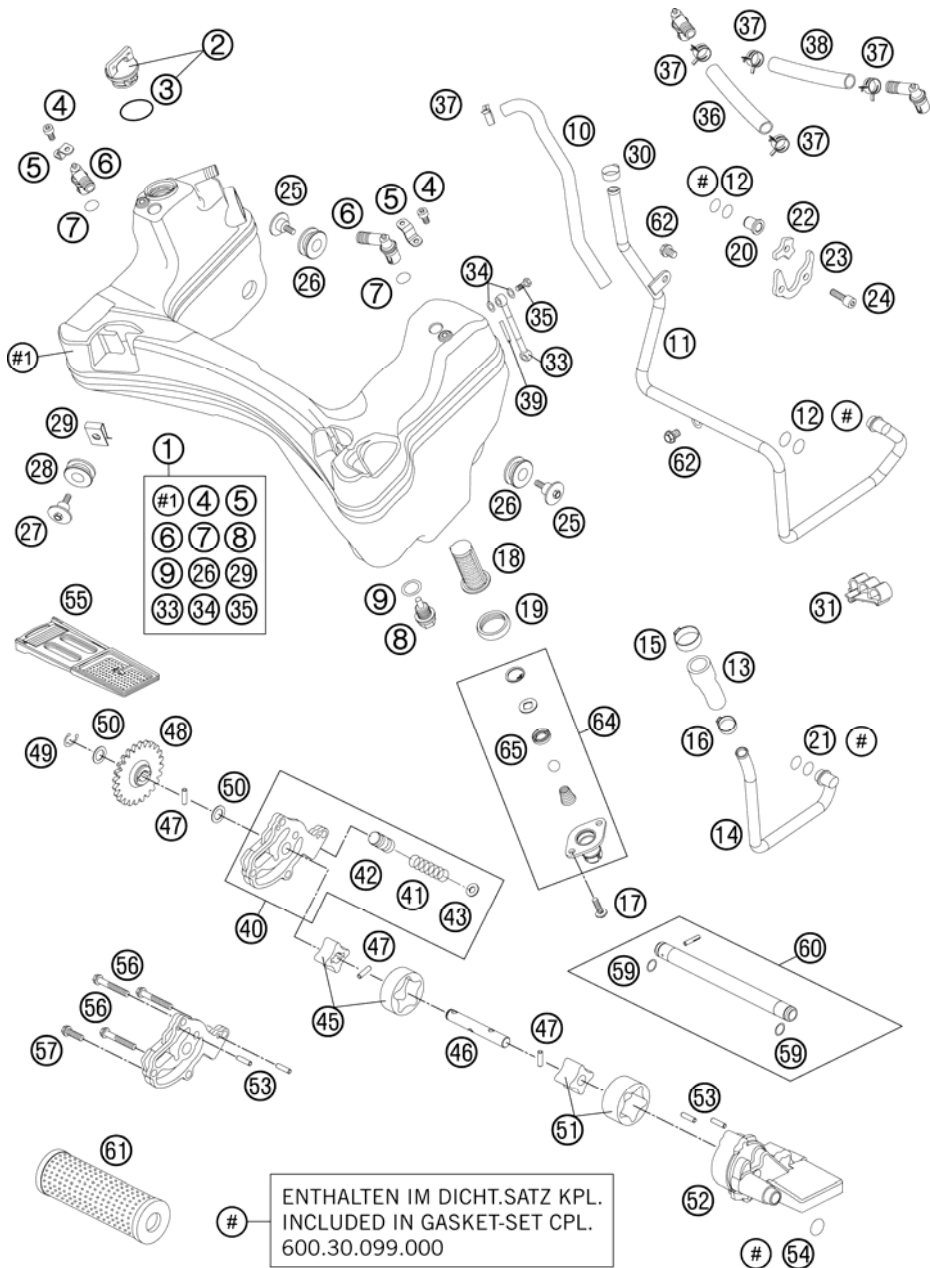

FIG	PART NUMBER	DESCRIPTION	QTY
37	00049160121	CLAMP STD DN16	5
38	60038059083	OIL TANK BREATHING HOSE L/S	1
39	61038085000	STICKER "OIL LEVEL" 05	1
40	60038010133	PRESSURE PUMP HOUSING CPL. 10	1
41	60038026000	CONTROL SPRING LC8 3,5 BAR	1
42	60038028000	CONTROL PISTON LC8 03	1
43	50337073000	SHIM	1
45*	60038011100	OIL PUMP ROTOR SET 14MM	1
46	60038002000	OIL PUMP SHAFT 03	1
47	0402041580	NEEDLE ROLLER NRB 4X15,8 G2	3
48	60038001124	OIL PUMP GEAR 24-T	1
49	0799080000	TAB WASHER DIN6799 RS8	1
50	60038007010	WASHER 10X16X0,5 03	2
51*	60038009100	OIL PUMP ROTOR COMPL. 19MM	1
52	60038008000	SUCTION PUMP CASE 03	1
53	0402040980	NEEDLE ROL.DIN5402 NRB 4X9,8	4
54	0770133024	O-RING 13,3X2,4 VITON	1
55	60038016000	OIL SCREEN 03	1
56	0025060406	HH COLLAR SCREW M6X40 TX30	3
57	0025060206	HH COLLAR SCREW M6X20 TX30	1
59	0770010010	O-RING 10,00X1,00 NBR 70 SH	2
60	60030065100	OIL INJECTION TUBE GEAR 05	1
61	60038015000	OIL FILTER 03	1
62	0025060106	HH COLLAR SCREW M6X10 TX30	2
64	60038060102	OIL TANK VALVE CPL.	1
65*	0760101844	SHAFT SEAL RING 10X18X4 BSL V.	1

116113810 / C126113810

\* NEW PART

X AS REQUIRED

# IGNITION SYSTEM

990 SUPERDUKE 2012

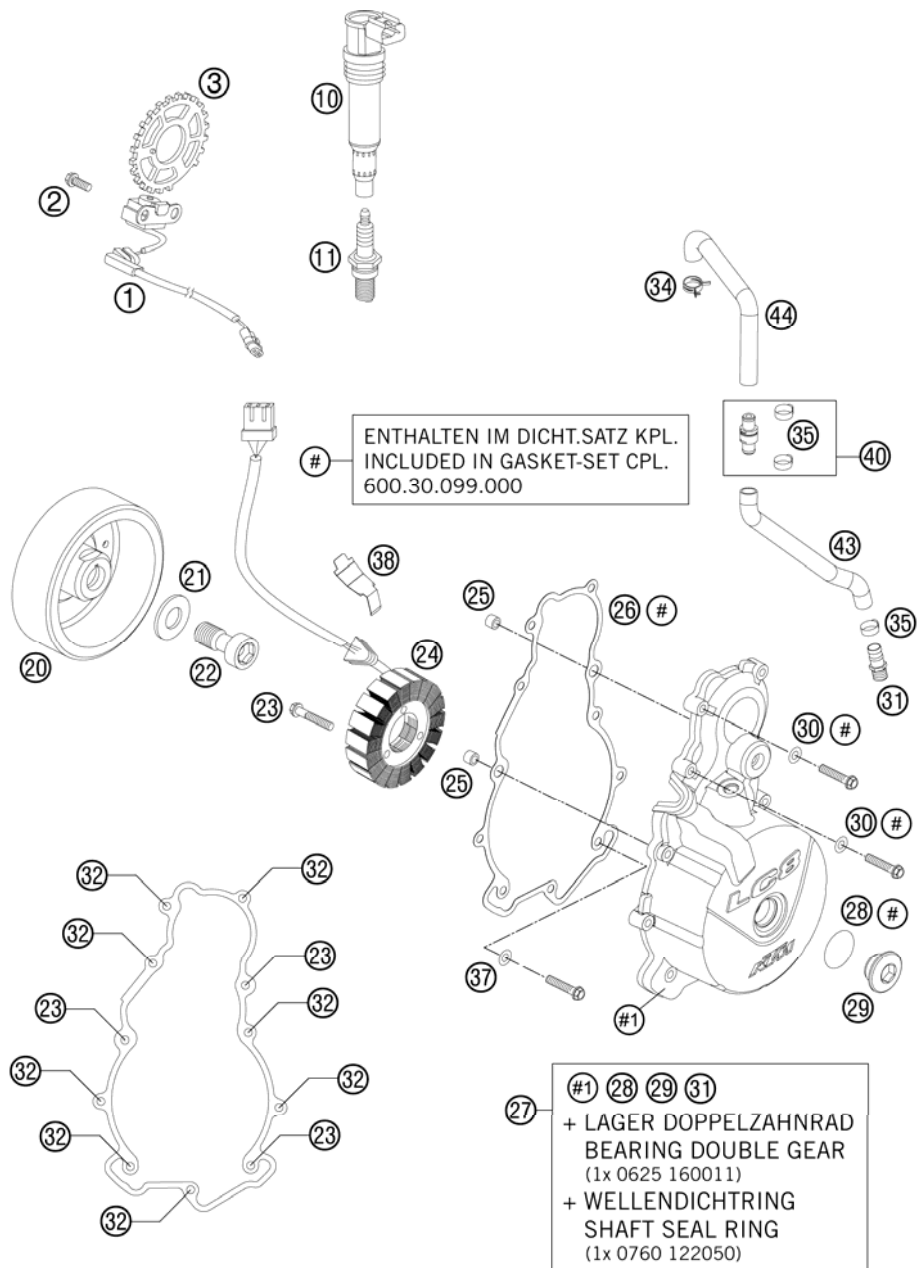

FIG	PART NUMBER	DESCRIPTION	QTY
1	60039034100	PULSE GENERATOR LC8 04	1
2	0025060166	HH COLLAR SCREW M6X16 TX30	2
3	61039020000	COIL SPROKET 22Z O. CYL. PIN	1
10	60039006000	STICK COIL 03	2
11	61139093000	SPARK PLUG KR8DI	2
20	60039005100	IGNITION ROTOR 04 INCL. FREEWHEEL	1
21	60039040010	WASHER 17X32X4 03	1
22	60039003100	AH EXPAND. SCREW M16X1,5 05	1
23	0025060356	HH COLLAR SCREW M6X35 TX30	6
24	60039004000	STATOR 03	1
25	49030090000	DOWEL 9,8 X 7 X 10	2
26	60030040100	IGNIT. COVER GASK.MATRI.CS0,5MM	1
27	6003000214423	IGNITION COVER CPL. 06	1
28	07700240251	O-RING 24X2,5 VITON	1
29	6003009400023	SCREW PLUG M24X1,5 PA 6.6	1
30	0603061001	CU-SEAL RING DIN7603-6X10X1	2
31	60030022000	VENTILATION CONNECTOR M16X1,5	1
32	0025060306	HH COLLAR SCREW M6X30 TX30	8
34	00049220121	CLAMP STD DN22	1
35	00050226706	VARIABLE ONE-EAR CLAMP 22,6MM	3
37	0125060003	WASHER DIN0125-A 6,4	1
38	60039040020	CABLE SUPPORT GENERATOR 03	1
40	60030090344	BACK-PRESSURE VALVE CPL.	1
43	60030087101	ENGINE BREATHER HOSE BOTTOM	1
44	60030087102	ENGINE BREATHER HOSE TOP	1

116113910 / C116113910

\* NEW PART

X AS REQUIRED

# ELECTRIC STARTER

990 SUPERDUKE 2012

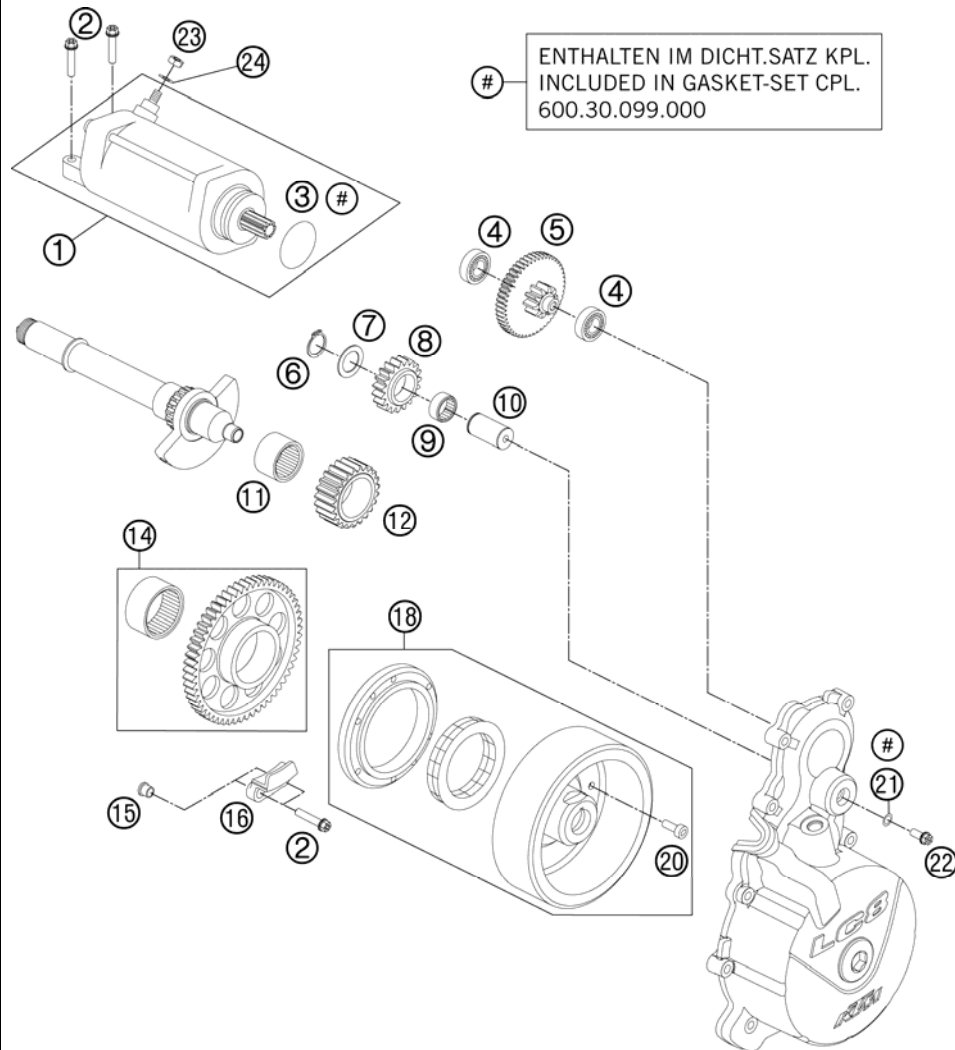

FIG	PART NUMBER	DESCRIPTION	QTY
1	60040001000	E-STARTER ENGINE CPL. LC8-E 03	1
2	0025060256	HH COLLAR SCREW M6X25 TX30	4
3	0770335030	O-RING 33,5X3 VITON	1
4	0625160011	GROOV.BALL BEAR. 16001 JRX C3	2
5	60040017000	TORQUE LIMITER	1
6	0471170010	CIRCLIP DIN0471-17X1	1
7	50333041000	STOP DISC 17,2X26X1 B	1
8	60040022219	IDLER GEAR 1 19Z	1
9	0405172110	NEEDLE BEARING K 17X21X10	1
10	60040023100	BEARING BOLT	1
11	0618253220	NEEDLE BUSH HK2520 25/32/20 02	1
12	60040022023	IDLER GEAR 2 23-T 03	1
14	60040020000	FREEWHEEL GEAR WH. 57-T CPL.03	1
15	60040027050	SUPPORTING SLEEVE 03	2
16	60040027000	FREEWHEEL HOLDER 03	1
18	60039005100	IGNITION ROTOR 04 INCL. FREEWHEEL	1
20	0984060166	AH SCREW DIN6912 M6X16 10.9	6
21	0603061001	CU-SEAL RING DIN7603-6X10X1	1
22	0025060166	HH COLLAR SCREW M6X16 TX30	1
23	0985060003	SELF LOCK. NUT DIN0985-M 6	1
24	0125060003	WASHER DIN0125-A 6,4	1

116114010 / C116114010

\* NEW PART

X AS REQUIRED

# THROTTLE BODY

990 SUPERDUKE 2012

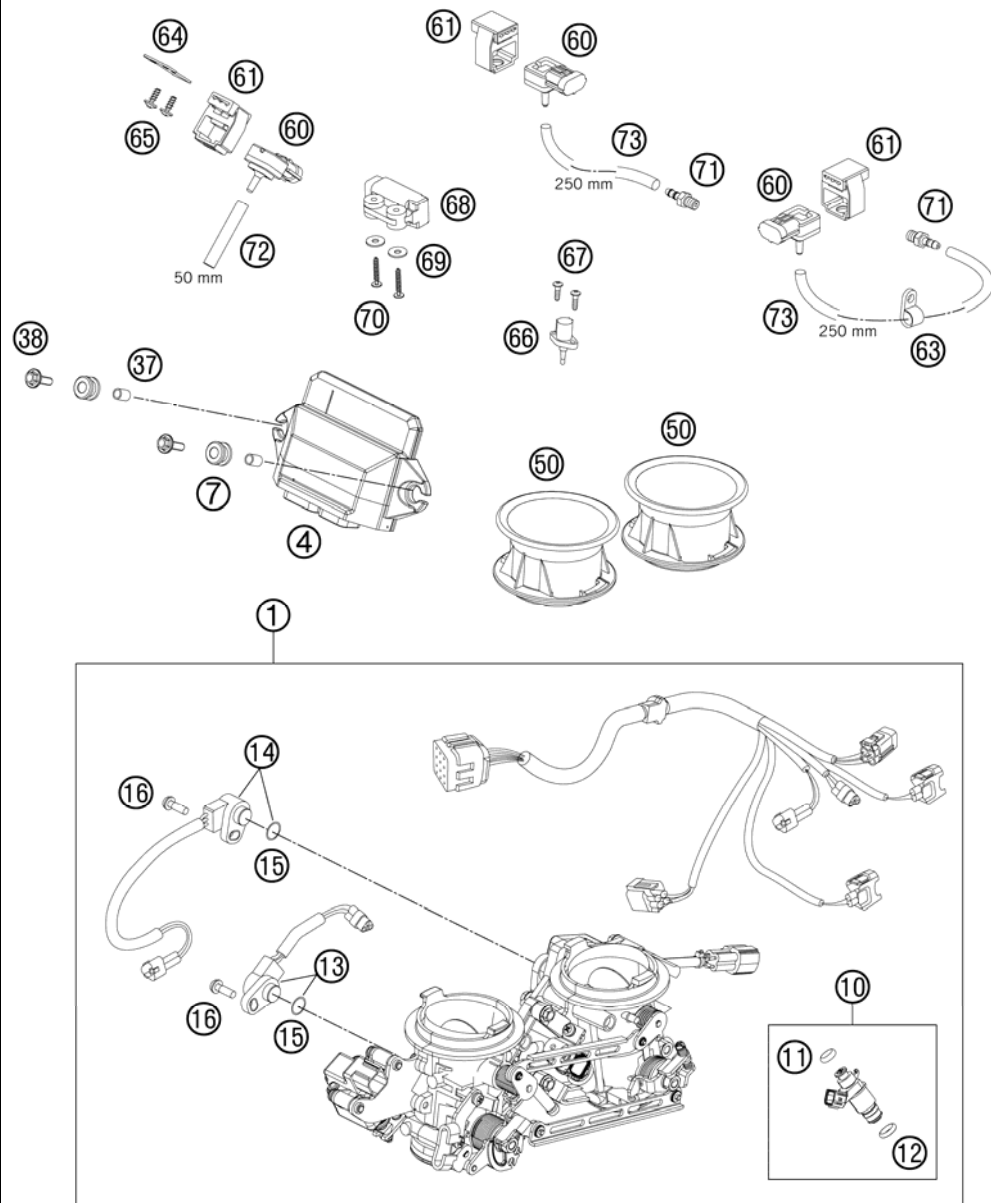

FIG	PART NUMBER	DESCRIPTION	QTY
1	61041001000	THROTTLE BODY CPL. 05	1
4	61041031200	TIMING CHARGER EFI 08	1
7	60039030000	VIBRATION DAMPER DIGITALBOX 03	2
10	61041023044	INJECTOR CPL. 2	2
11	61041023010	O-RING INJECTOR 2	2
12	61041023020	O-RING INJECTOR 2	2
13	61041077000	THROTTLE POS. SENSOR CPL. 1	1
14	61041177000	THROTTLE POS. SENSOR CPL. 1	1
15	61041077010	O-RING THROTTLE POS. SENSOR 2	2
16	61041077020	SCREW THROTTLE POS. SENSOR 2	2
37	61141028000	SPACER BUSHING 6,3X8,5X11 07 2	2
38	0024060206	HH COLLAR SCREW M6X20 TX30 2	2
50	61041040000	INTAKE TRUMPET 05 2	2
60	61041085100	PRESSURE SENSOR 06 3	3
61	61041085150	RUBBER SUPP. PRESSURE SENS. 06 3	3
63	57013070100	PVC-CLAMP 7,9 MM HEYCO 3355 1	1
64	61041085060	SUPPORT PRESSURE SENSOR 05 1	1
65	0081050121	SCREW FOR PLASTIC K50X12 T20 2	2
66	61041080000	AMBIENT-AIR TEMPERATURE SENSOR 1	1
67	0081050181	SCREW FOR PLASTIC K50X18 T20 2	2
68	61041088000	ROLLOVER SENSOR 05 1	1
69	61041088050	SHIM 4,3X15X1,25MM GALVANIZED 2	2
70	0081400253	PLASTIC SCREW KA40X25WN1412 2	2
71	61036023100	VACUUM CONECTION 2006 2	2
72	61041095050	HOSE 3,2X8,5 L=50 MM 05 1	1
73	61041095250	HOSE 3,2X8,5 L= 250 MM 05 2	2

116114110 / C116114110

\* NEW PART

X AS REQUIRED





KTM-Sportmotorcycle AG  
A-5230 Mattighofen  
[www.ktm.at](http://www.ktm.at)

KTM Group Partner



3CM089820LEN



Art.Nr.: 3CM089820LEN 12/2011