

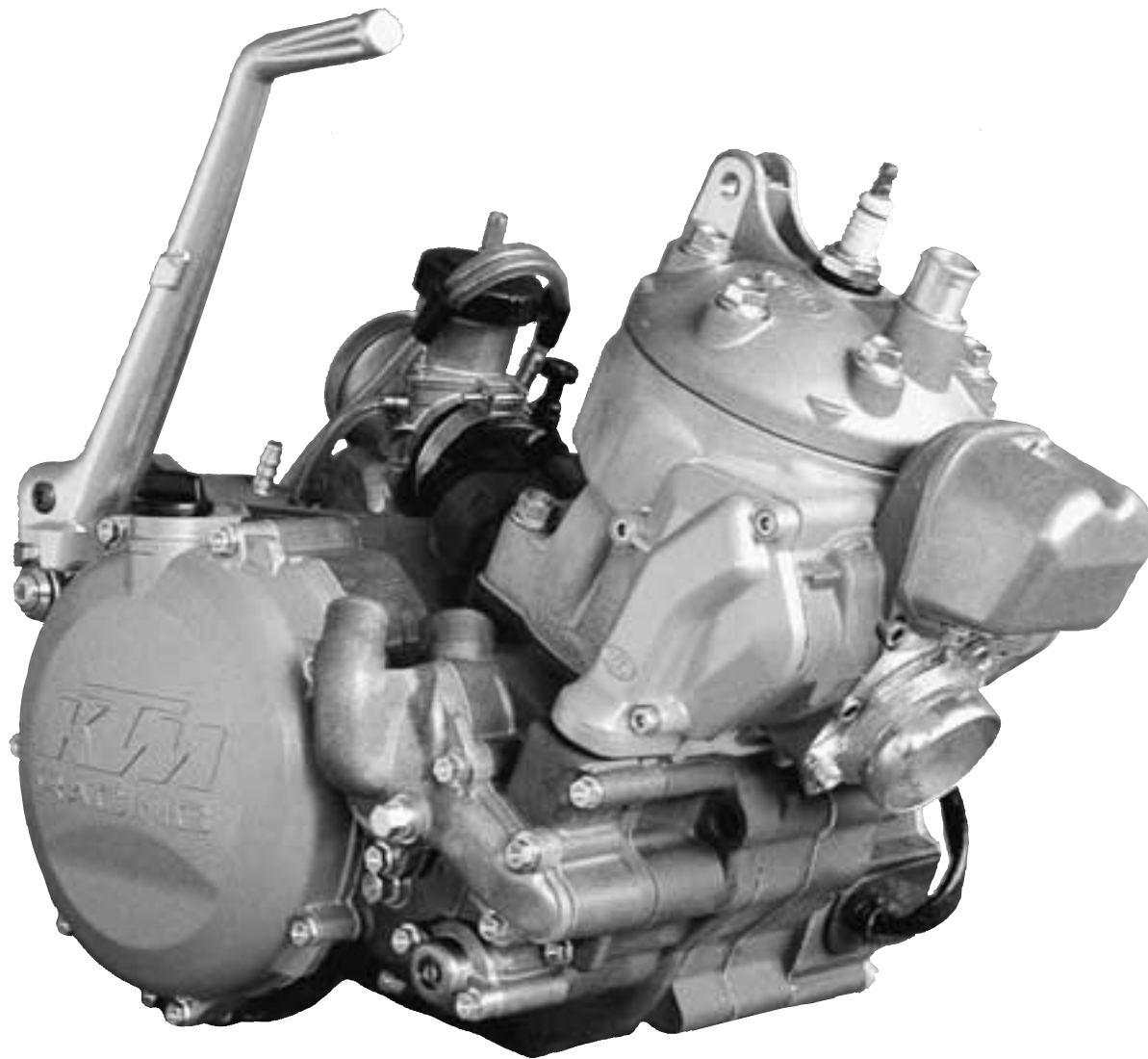

ERSATZTEILKATALOG '98

SPARE PARTS MANUAL



MOTOR ENGINE

250/300 380

TECHNISCHE DATEN / TECHNICAL DATA

ART.NR. 3.204.19
7.97



INHALTSVERZEICHNIS

INDEX

MOTERGEHÄUSE ENGINE CASE

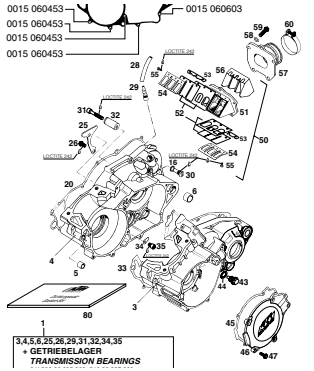

SEITE
Page
3

KUPPLUNGSDECKEL CLUTCH COVER

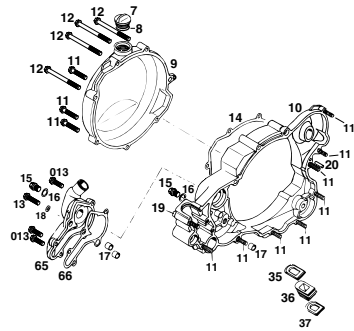

SEITE
Page
4

KURBELWELLE, KOLBEN CRANKSHAFT, PISTON

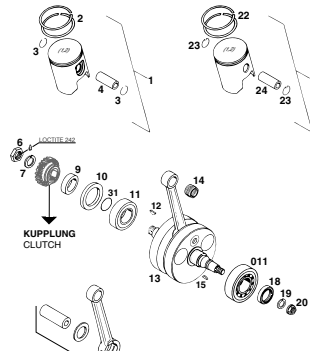

SEITE
Page
5

ZYLINDER CYLINDER

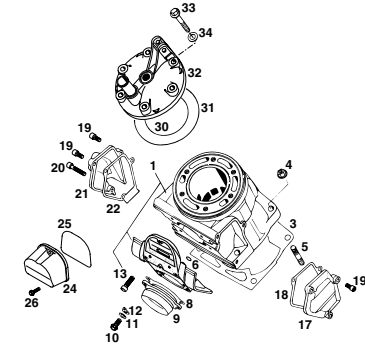

SEITE
Page
6

AUSLASSTEUERUNG TWIN VALVE CONTROL

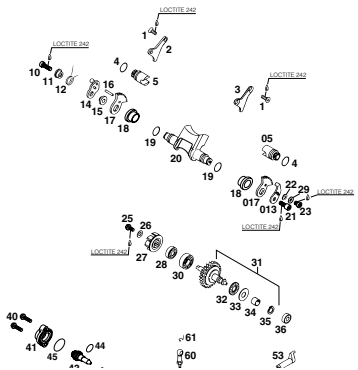

SEITE
Page
7

VERGASER KEIHIN PWK 38 VERGASER KEIHIN PWK 38

ACHTUNG !!!
Vor dem Einbau des Vergasers, Bedüsung kontrollieren.
CAUTION !!!
Before mounting the carburetor, check the jetting.

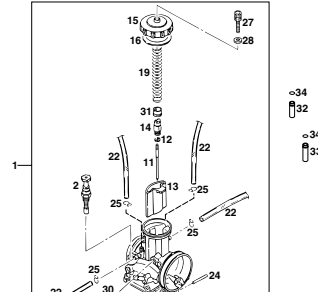

SEITE
Page
9

ZÜNDANLAGE KOKUSAN IGNITION SYSTEM KOKUSAN

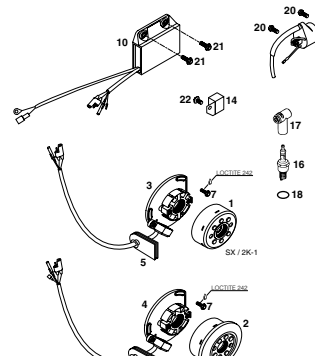

SEITE
Page
11

ZÜNDANLAGE SEM IGNITION SYTEM SEM

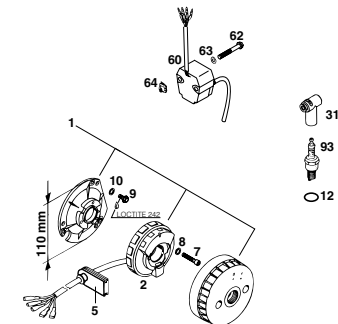

SEITE
Page
12

KUPPLUNG CLUTCH

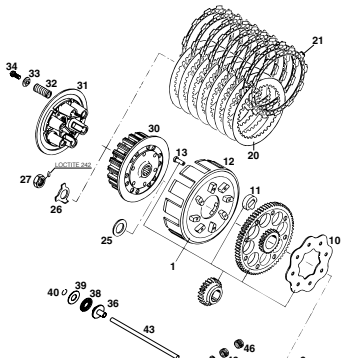

SEITE
Page
13

KICKSTARTER KICKSTARTER

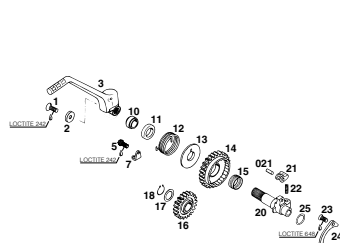

SEITE
Page
14

GETRIEBE I TRANSMISSION I

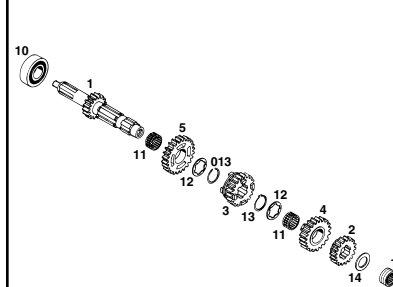

SEITE
Page
15

GETRIEBE II TRANSMISSION II

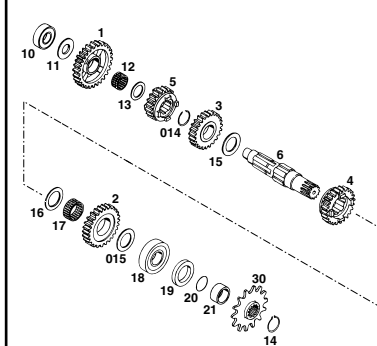

SEITE
Page
16



INHALTSVERZEICHNIS

INDEX

SCHALTUNG SHIFTING MECHANISM

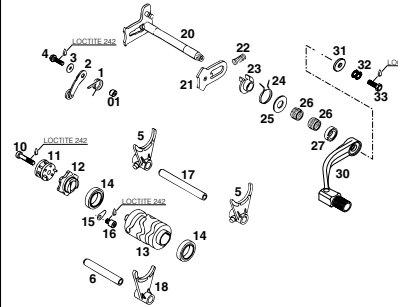

SEITE
Page
17

KÜHLSYSTEM COOLING SYSTEM

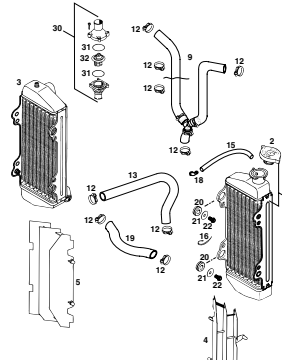

SEITE
Page
18

SPEZIALWERKZEUG SPECIAL TOOLS

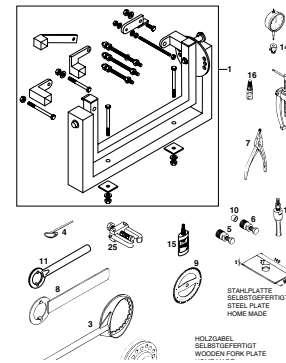

SEITE
Page
19

TECHNISCHE DATEN MOTOR TECHNICAL DATA ENGINE

TECHNISCHE DATEN - MOTOR 250/300/380			
	250 SX	250 EXC, EGS	300 EXC, EGS
Motor			
Bozart	250 SX	Flüssigkeitskühlter Einzylinder-Zweiventil-Motor mit KTM Top-Motiv-Cam	
Hälraum	249 cm ³	297 cm ³	
Bohrung / Hub	87,5 / 40,5 mm	72 / 72 mm	
Kurbel	Spezialschiff R02 95 Blech, mit hochwertigen Zweiventil je		
Mischungsverhältnis	1,50 - 1,60 bei Verwendung von hochwertigen Zweitaktölen. Im Zweifelsfall setzen Sie sich bitte mit		
Kurbelwellenlager	1 Kurbelwellenlager / 1 Zylinderkopf		
Pleuelager	Nadellager		
Kurbelwellenlager	Nadellager		
Kollen	Schmiedestücken		
Kollenring	2 Rechteckringe		
Maß "X" Dimension	0 ± 0,1 mm		
Zylinderbohrung	1,9 mm (17 Grad) vor OT	1,2 mm (13,5 Grad) vor OT	1,2 mm (13,5 Grad) vor OT
Zylinderkerze	NGK BR 8 ECA		
Pleuellagerabstand	0,60 mm		
Pleuellager	46 mm		
TVC Verstelllager	5300/min		
TVC Verstellring	2750/min		
Pleuellager	Gewebe verzahnte Steindrücker, Pleuellagerung 23/72		
Pleuellager	Mehrscheibenkupplung im Ölbad		
Pleuellager	Motorengehäuse 5-Gang-Getriebe		
Pleuellager	0,8 Material 20W-40 (Shell Advor)		
Pleuellager	14,50 / 14,50 / 15,40 / 15,40 / 13,50 4,50 / 15,48 / 13,40		
Pleuellager	122 / 482 / 112 104 mm 104		
Pleuellager	382 / 402 / 452 / 482 / 502 / 522		
Pleuellager	1,3 Liter, Mischungsverhältnis 40% Frischöl, 60% W		
Pleuellager	KÜHLSTAN 2K1 20W-40		

SEITE
Page
21



KONSTRUKTIONS- UND AUSFÜHRUNGSÄNDERUNGEN VORBEHALTEN

SPECIFICATIONS/MODIFICATIONS ARE SUBJECT TO CHANGE WITHOUT NOTICE

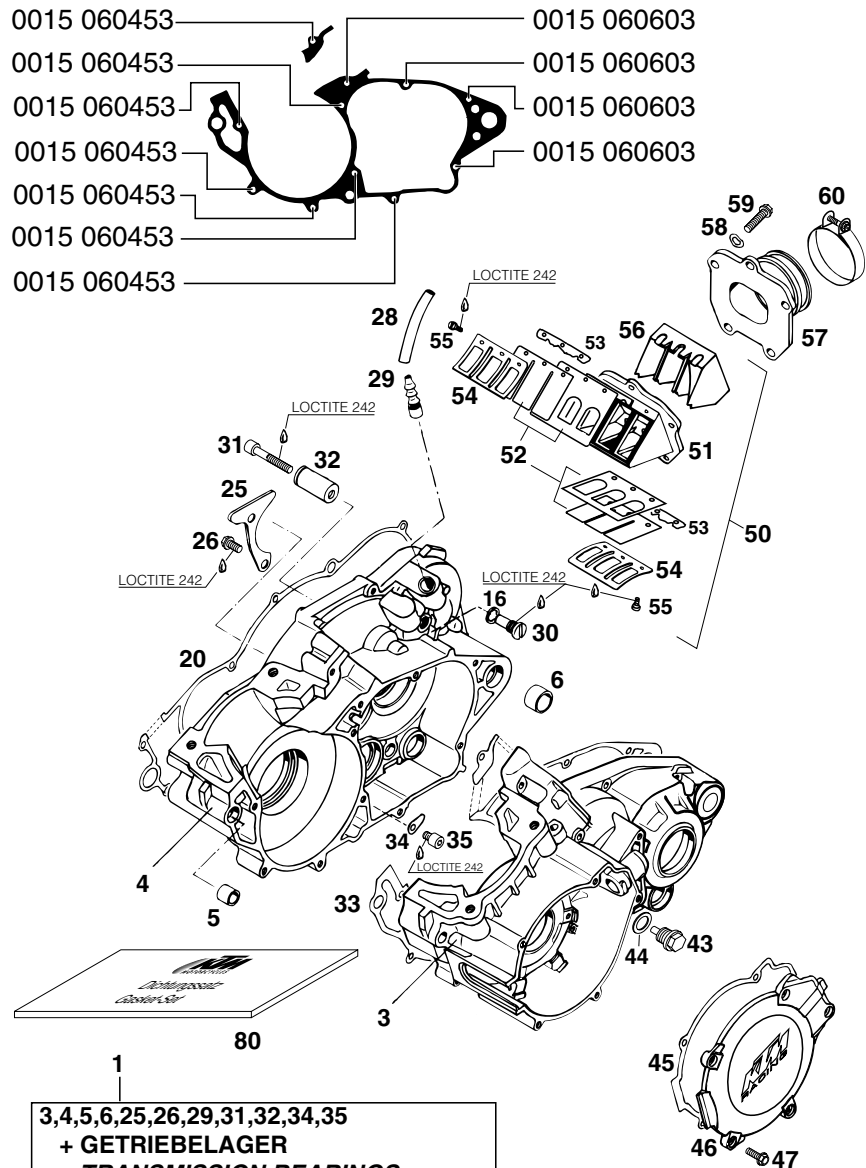

3,4,5,6,25,26,29,31,32,34,35
+ GETRIEBELAGER
TRANSMISSION BEARINGS
 2 X 502.32.095.000, 546.33.027.000
 2 X 0991 060122, 0625 201029, 565.33.093.000,
 0625 062031, 0625 613742, 2 X 0625 618050

FIG	TEILNR/PARTNR	BEZEICHNUNG	DESCRIPTION	QTY
1*	546.30.000.944	MOTERGEHÄUSE KPL. MIT LAGER'98	ENGINE CASE CPL.W.TRAN.BEAR'98	1
5	546.30.027.000	PASSBÜCHSE 13,8X11X12	DOWEL BUSHING 13,8X11X12	1
6	501.30.027.000	PASSHÜLSE 19 X15,1X12	DOWEL 19 X15,1X12	1
16	580.38.032.110	CU-DICHRING 9 X 13 X 1	CU-SEAL RING 9 X 13 X1	1
20	546.30.025.100	KUPPLUNGSDECKELDICHTUNG	CLUTCHCOVER GASKET	1
25	546.30.017.000	HALTEBLECH	RETAINING PLATE	1
26	0015 060123	SK.BUNDSCHRAUBE M 6X12 SW=8	HH COLLAR SCREW M 6X12 WS=8	2
28	550.07.016.001	SCHLAUCH 7X10 PER METER	PVC-HOSE 7X10 PER METER	0,25
29	546.30.022.000	ENTLÜFTUNGSSTUTZEN '94	BLEEDER FLANGE '94	1
30	545.30.001.150	FLACHKOPFSCHRAUBE M.ZAPFEN	FLAT HEAD SCREW WITH PIN	1
31	0912 060404	ISK.SCHRAUBE DIN0912-M 6X40	AH SCREW DIN0912-M 6X40	1
32	546.33.018.400	LAGERZAPFEN F. STARTERZW.RAD	BEARING PIN	1
33*	546.30.039.200	GEHÄUSEDICHT. 0,5MM 250-380'98	CASE GASKET 0,5MM 250-380'98	1
34	546.34.049.000	HALTEBLECH	RETAINING PLATE	2
35	0912 060083	ISK.SCHRAUBE DIN0912-M 6X 8	AH SCREW DIN0912-M 6X 8	2
43	580.30.021.000	ÖLABLASSCHR.B.M.MAGNET M12X1,5	OILDRAIN PLUG W.MAGNET M12X1,5	1
44	580.38.022.000	CU-DICHRING 12 X 18 X 1,5	CU-SEAL RING 12 X 18 X 1,5	1
45	546.30.040.300	ZÜNDDECKELDICHTUNG '92	IGNITION COVER GASKET '92	1
46*	546.30.002.300	ZÜNDUNGSDECKEL 250-380 '98	IGNITION COVER 250-380 '98	1
47	0015 050163	SK.BUNDSCHRAUBE M 5X16 SW=8	HH COLLAR SCREW M 5X16 WS=8	5
50	546.30.051.344	MEMBRANGEHÄUSE KPL. 250-360'96	REED VALVE HOUSING 250-360'96	1
51	544.30.051.000	MEMBRANGEHÄUSE LOSE	REED VALVE CASE LOOSE	1
52	546.30.052.600	MEMBRANE KPL. 250/300/360 '96	REED VALVE CPL. 250/300/360'96	1
53	542.30.056.000	UNTERLEGSTREIFEN	PAPER STRIP	2
54	546.30.053.000	ANSCHLAGBLECH	STOP PLATE TOP	2
55	0084 040083	ZYL.SCHRAUBE DIN0084-M 4X 8 A	CYL.HEAD SCREW DIN0084-M 4X 8	6
56	546.30.054.000	MEMBRANEINSATZ	VELOCITY INSERT	1
57	546.30.050.000	ANSAUGFLANSCH	INTAKE FLANGE	1
58	0137 060000	FEDERSCHEIBE DIN0137-B 6	SPRING WASHER DIN0137-B 6	5
59	0015 060253	SK.BUNDSCHRAUBE M 6X25 SW=8	HH COLLAR SCREW M 6X25 WS=8	5
60	543.30.061.000	SCHELLE 52/12 GEMI	CLAMP 52/12 GEMI	1
80	546.30.100.000	DICHTUNGSSATZ 250-380 '90-'98	GASKET SET 250-380 '90-'98	1

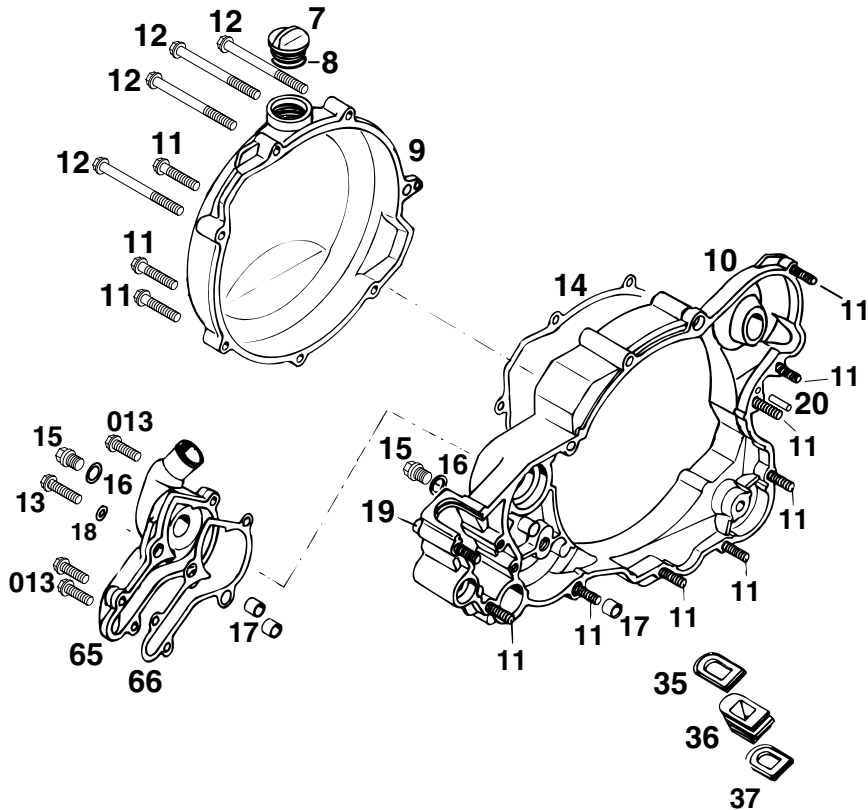

FIG	TEILNR/PARTNR	BEZEICHNUNG	DESCRIPTION	QTY
7	580.30.020.000	ÖLEINFÜLLSCHRAUBE M24 X 3	PLUG M24 X 3	1
8	0770 160030	O-RING 16,00X3,00 NBR 70	O-RING 16,00X3,00 NBR 70	1
9*	546.30.101.000/90	KUPPLUNGSAUSSENDECKEL '98	OUTER CLUTCH COVER '98	1
10	546.30.001.300	KUPPLUNGSDECKEL 250/300/360'96	CLUTCH COVER 250/300/360 '96	1
11	0015 060303	SK.BUNDSCHRAUBE M 6X30 SW=8	HH COLLAR SCREW M 6X30 WS=8	11
12	0015 060703	SK.BUNDSCHRAUBE M 6X70 SW=8	HH COLLAR SCREW M 6X70 WS=8	4
13	0015 060253	SK.BUNDSCHRAUBE M 6X25 SW=8	HH COLLAR SCREW M 6X25 WS=8	2
013	0015 060203	SK.BUNDSCHRAUBE M 6X20 SW=8	HH COLLAR SCREW M 6X20 WS=8	3
14	546.30.025.050	KUPPLUNGSAUSSENDECKELDICHTUNG	OUTER CLUTCH COVER GASKET	1
15	0910 100003	VERSCHL.SCHR. DIN0910-M10X1	PLUG DIN0910-M10X1	2
16	420.13.226.000	CU-DICHTRING DIN7603-10X16X1	CU-SEAL RING DIN7603-10X16X1	2
17	490.30.090.000	PASSHÜLSE 9,8 X 7 X 10	DOWEL 9,8 X 7 X 10	3
18	580.36.065.000	CU-DICHTRING 6 X 10 X 1	CU-SEAL RING 6 X 10 X 1	2
19	0015 060453	SK.BUNDSCHRAUBE M 6X45 SW=8	HH COLLAR SCREW M 6X45 WS=8	1
20	0007 050160	ZYLINDERSTIFT DIN0007- 5X16	CYLINDER PIN DIN0007- 5X16	1
35	546.37.207.000	DICHTELEMENT OBEN	SEALING ELEMENT TOP	1
36	546.37.007.000	ABDICHTUNG	GASKET	1
37	546.37.107.000	DICHTELEMENT UNTEN	SEALING ELEMENT BOTTOM	1
65	546.35.001.000	WASSERPUMPENDECKEL	WATER PUMP COVER	1
66	546.35.003.200	WASSERPUMPENDECKELDICHTUNG	WATER PUMP COVER GASKET	1

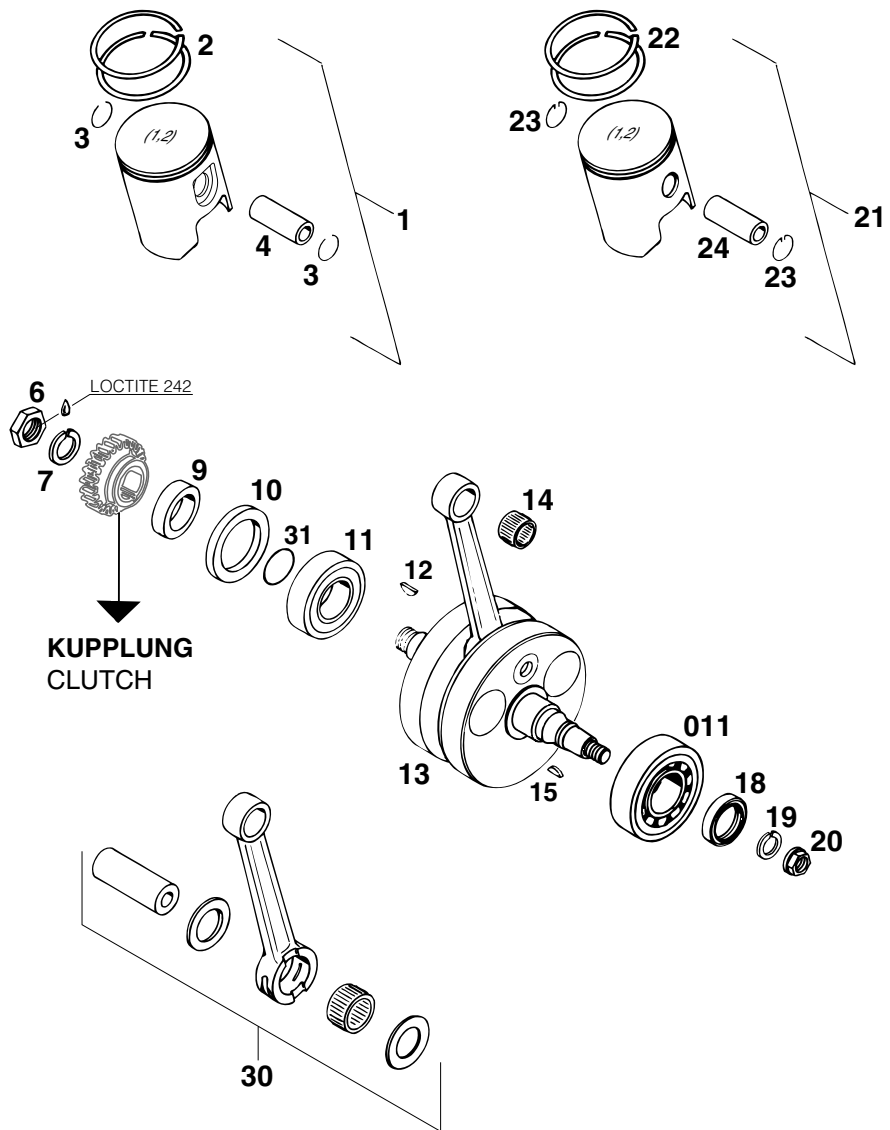

FIG	TEILNR/PARTNR	BEZEICHNUNG	DESCRIPTION	QTY
1*	546.30.007.500/ I	KOLBEN I KPL. 67,5MM 250'98	PISTON I CPL. 67,5MM 250'98	1
1*	546.30.007.500/ II	KOLBEN II KPL. 67,5MM 250'98	PISTON II CPL. 67,5MM 250'98	1
1*	547.30.007.200/ I	KOLBEN I KPL. 78,0MM 380'98	PISTON I CPL. 78,0MM 380'98	1
1*	547.30.007.200/ II	KOLBEN II KPL. 78,0MM 380'98	PISTON II CPL. 78,0MM 380'98	1
2	546.30.032.000	R-RING 67,5X1 250 CC	SQUARE RING 67,5X1 250 CC	2
2	547.30.032.000	R-RING 78,0X1,25 360/380 CC	SQUARE R. 78,0X1,25 360/380 CC	2
3*	540.30.074.000	DRAHTSPRENGRING C18X1,5	WIRE LOCK RING C18X1,5	2
4	547.30.033.000	KOLBENBOLZEN 18 X 48	PISTON PIN 18 X 48	1
6	546.30.029.000	SK-MUTTER M18X1,5-LINKS	HEX.NUT L/SH M18X1,5	1
7	581.32.072.000	SPERRKANTRING VSK 18	LOCK WASHER VSK 18	1
9	546.30.016.400	DISTANZHÜLSE 28X38X11,5	SPACER SLEEVE 28X38X11,5	1
10	0760 385273	WELLENDICHTRING 38X52X7 BTSL	SHAFT SEAL RING 38X52X7BTSL	1
11	0625 622064	RILLENKUGELLAGER 62206.803107	BALL BEARING 62206.803107	1
011	565.30.123.100	ZYLINDERROLLENLAGER NJ207 NSK	CYLIND.ROLLER BEARING NJ207NSK	1
12	0888 050650	SCHEIBENFEDER DIN6888-5X6,5	WOODRUFF KEY DIN6888-5X6,5	1
13	546.30.018.400	KURBELWELLE HUB 69,5 „250“	CRANKSHAFT STROKE 69,5 „250“	1
13	546.30.318.400	KURBELWELLE HUB 73 „300“	CRANKSHAFT STROKE 73 „300“	1
13*	547.30.018.500	KURBELWELLE HUB 77 „380“	CRANKSHAFT STROKE 77 „380“	1
14	544.30.034.000	NADELLAGER KBK 18X22X20	NEEDLE BEARING KBK 18X22X20	1
15	0888 030050	SCHEIBENFEDER DIN6888-3X5X13	WOODRUFF KEY DIN6888-3X5X13	1
18	0760 253570	WELLENDICHTRING 25X35X7 BTSL	SHAFT SEAL RING 25X35X7 BTSL	1
19	502.30.029.012	SPERRKANTRING VSK 12	LOCKING RING VSK 12	1
20	490.30.021.000	BUNDMUTTER M12X1 RECHTS	COLLAR NUT M12X1 R/S	1
21	546.30.307.400/ I	KOLBEN I KPL. 72,0MM 300'96	PISTON I CPL. 72,0MM 300'96	1
21	546.30.307.400/ II	KOLBEN II KPL. 72,0MM 300'96	PISTON II CPL. 72,0MM 300'96	1
22	546.30.332.000	R-RING 72,0X1,25 300 CC	SQUARE RING 72,0X1,25 300 CC	2
23	543.30.074.000	DRAHTSPRENGRING SKA 18	WIRE LOCK RING SKA 18	2
24	546.30.033.000	KOLBENBOLZEN 18 X 44	PISTON PIN 18 X 44	1
30	546.30.015.044	PLEUEL-REP.SATZ 250/300 '96	CONROD REPAIR KIT 250/300 '96	1
30	547.30.015.000	PLEUEL-REP. SATZ 360/380 '97	CON.ROD REPAIR KIT 360/380 '97	1
31	0770 250015	O-RING 25,00X1,50 NBR 70	O-RING 25,00X1,50 NBR 70	1

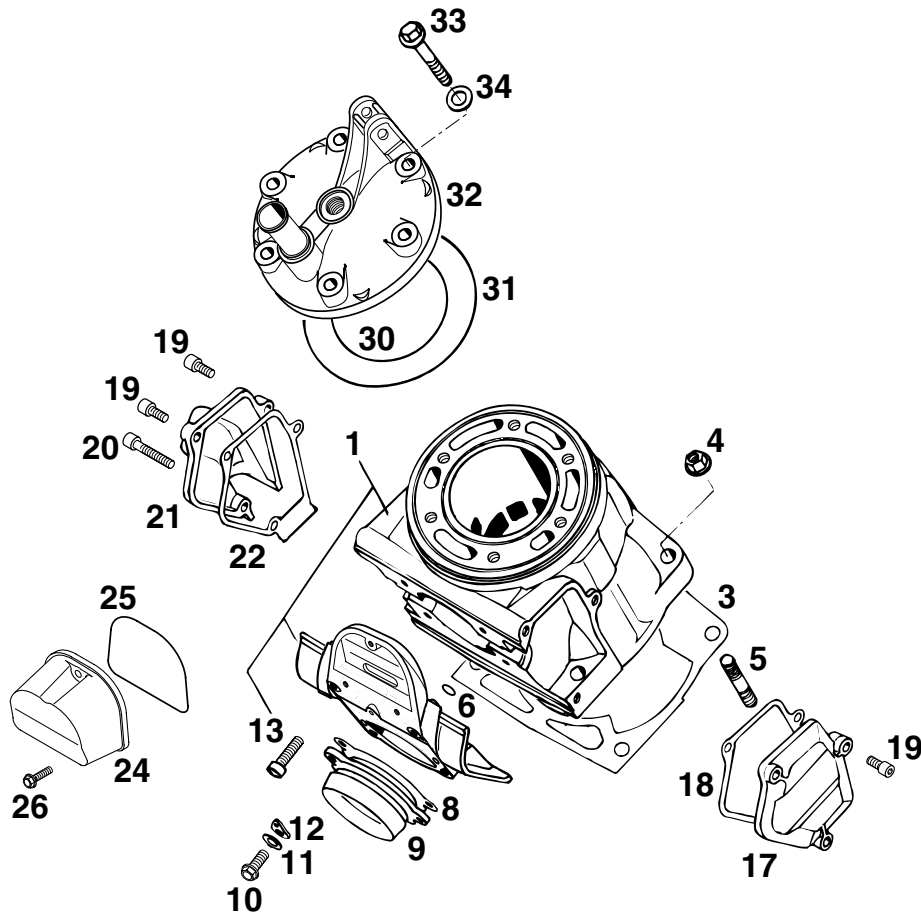

FIG	TEILNR/PARTNR	BEZEICHNUNG	DESCRIPTION	QTY
1*	546.30.105.144	ZYLINDER KPL.M.FLANSCH 250'98	CYLINDER CPL.W.FLANGE 250'98	1
1*	546.30.405.144	ZYLINDER KPL.M.FLANSCH 300'98	CYLINDER CPL.W.FLANGE 300'98	1
1*	547.30.005.244	ZYLINDER KPL.M.FLANSCH 380'98	CYLINDER CPL.W.FLANGE 380'98	1
3	546.30.030.102	ZYL.FUSSDICHTUNG 0,20MM '96	CYLINDER BASE GASKET 0,20MM'96	X
3*	546.30.030.104	ZYL.FUSSDICHTUNG 0,40MM '98	CYLINDER BASE GASKET 0,40MM'98	X
3	546.30.030.105	ZYL.FUSSDICHTUNG 0,50MM '96	CYLINDER BASE GASKET 0,50MM'96	X
3	546.30.030.107	ZYL.FUSSDICHTUNG 0,75MM '96	CYLINDER BASE GASKET 0,75MM'96	X
4	546.30.044.000	BUNDMUTTER M10 SW=13	COLLAR NUT M10 WS=13	4
5	0835 100351	STIFTSCHRAUBE DIN0835-M10X35 250/300	STUD DIN0835-M10X35 250/300	4
5	0835 100403	STIFTSCHRAUBE DIN0835-M10X40 380	STUD DIN0835-M10X40 380	4
6	0770 116241	O-RING 11,3 X2,4 SILICON	O-RING 11,3 X2,4 SILICON	4
8	546.30.046.000	AUSPUFFSTUTZENDICHTUNG	EXHAUST FLANGE GASKET	1
9	546.05.073.000	AUSPUFFFLANSCH	EXHAUST FLANGE	1
10	0015 060163	SK.BUNDSCHRAUBE M 6X16 SW=8	HH COLLAR SCREW M 6X16 WS=8	3
11	0137 060000	FEDERSCHEIBE DIN0137-B 6	SPRING WASHER DIN0137-B 6	3
12	510.05.074.000	FEDERLASCHE	RETAINING PLATE	3
13	0912 060303	ISK.SCHRAUBE DIN0912-M 6X30	AH SCREW DIN0912-M 6X30	4
17	546.37.105.000	SEITENDECKEL LINKS	CONTROL COVER L/S	1
18	546.37.106.000	DICHTUNG FÜR SEITENDECKEL	GASKET FOR SIDE COVER	1
19	0912 050123	ISK.SCHRAUBE DIN0912-M 5X12	AH SCREW DIN0912-M 5X12	5
20	0912 050303	ISK.SCHRAUBE DIN0912-M 5X30	AH SCREW DIN0912-M 5X30	1
21	546.37.005.000	STEUERUNGSDECKEL RECHTS	CONTROL COVER R/S	1
22	546.37.006.100	DICHTUNG FÜR STEUERUNGSDECKEL	GASKET FOR CONTROL COVER	1
24*	547.37.010.000	ZWISCHENFLANSCHDECKEL KTC '98	FLANGE COVER KTC '98	1
25*	0770 690020	O-RING 69,00X2,00 NBR 70	O-RING 69,00X2,00 NBR 70	1
26	0015 050203	SK.BUNDSCHRAUBE M 5X20 SW=8	HH COLLAR SCREW M 5X20 WS=8	3
30	0770 740021	O-RING 74,00X2,00 SILICON	O-RING 74,00X2,00 SILICON	1
30	0770 780021	O-RING 78,00X2,00 SILICON	O-RING 78,00X2,00 SILICON	1
30	0770 840021	O-RING 84,00X2,00 SILICON	O-RING 84,00X2,00 SILICON	1
31	0770 114020	O-RING 114,00X2,00 SILICON	O-RING 114,00X2,00 SILICON	1
32	546.30.006.600	ZYLINDERKOPF „2501“ 250'96	CYLINDER HEAD „2501“ 250'96	1
32	546.30.306.600	ZYLINDERKOPF „3001“ 300'96	CYLINDER HEAD „3001“ 300'96	1
32	547.30.006.100	ZYLINDERKOPF „3602“ 360/380'97	CYLINDER HEAD „3602“360/380'97	1
33	565.30.079.000	BUNDSCHRAUBE M8X42-10.9	SPECIAL SCREW M8X42-10.9	6
34	565.30.080.000	CU-DICHRING 8 X 16 X 1	CU-SEAL RING 8 X 16 X 1	6

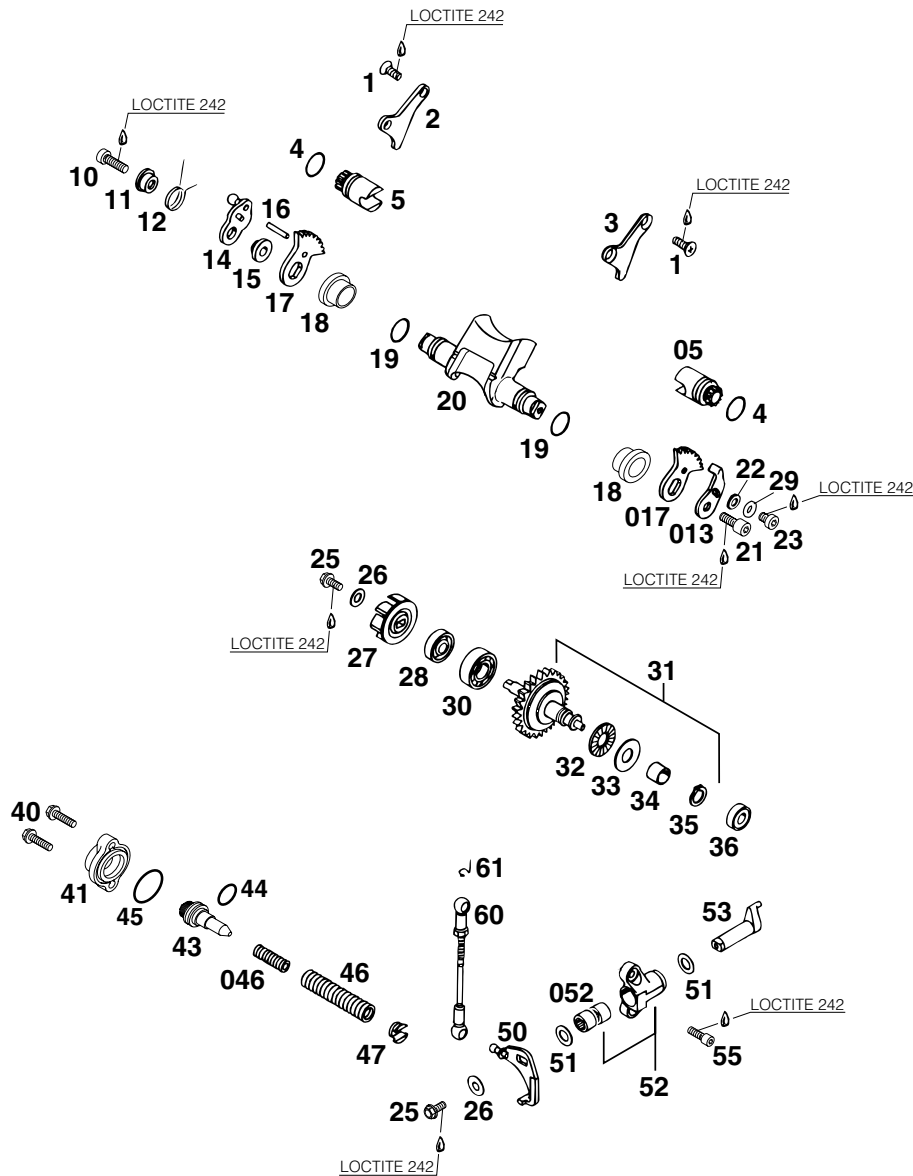

FIG	TEILNR/PARTNR	BEZEICHNUNG	DESCRIPTION	QTY
1	0965 050103	SENKSCHRAUBE DIN0965-M 5X10	FLAT HEAD SCREW DIN0965-M 5X10	4
2	546.37.062.000	HALTEBLECH RECHTS 250	RETAINING PLATE R/S 250	1
2	546.37.362.000	HALTEBLECH RECHTS 300/360/380	RETAINING PLATE R/S 300/360/380	1
3	546.37.063.000	HALTEBLECH LINKS 250	RETAINING PLATE L/S 250	1
3	546.37.363.000	HALTEBLECH LINKS 300/360/380	RETAINING PLATE L/S 300/360/380	1
4	0770 160021	O-RING 16,00X2,00 SILICON	O-RING 16,00X2,00 SILICON	2
05	546.37.061.444	STEUERW. KPL. LINKS „L“ 250'96	CONTROL ROLLER L/S „L“ 250'96	1
05	546.37.361.444	STEUERW. KPL.LI.„L“300/360/380	CONTR. VALVE L/S „L“300/360/380	1
5	546.37.061.544	STEUERWALZE KPL. RECHTS 250'96	CONTROL ROLLER CPL. R/S 250'96	1
5	546.37.361.544	STEUERWALZE KPL.RE.300/360/380	CONTROL VALVE R/S 300/360/380	1
10	0984 060203	ZYL.SCHRAUBE DIN6912-M 6X20	AH SCREW DIN6912-M 6X20	1
11	546.37.067.000	FEDERHÜLSE	SPRING SLEEVE	1
12	546.37.066.000	ÜBERLASTFEDER	OVERLOAD SPRING	1
013	546.37.085.300	ANSCHLAGBLECH STEUERKLAPPE '92	RETAIN.PLATE CONTROL FLAP '92	1
14	546.37.065.000	EINSTELLHEBEL	CONTROL LEVER WITH BALL TYPE	1
15	546.37.068.100	LAGERHÜLSE	BEARING SLEEVE	1
16	0007 050160	ZYLINDERSTIFT DIN0007- 5X16	CYLINDER PIN DIN0007- 5X16	1
17	546.37.064.000	ZAHNSEGMENT RECHTS 250	GEAR SEGMENT R/S 250	1
017	546.37.064.050	ZAHNSEGMENT LINKS M6 250	GEAR SEGMENT L/S M6 250	1
17	546.37.364.000	ZAHNSEGMENT RECHTS 300/360/380	GEAR SEGMENT R/S 300/360/380	1
017	546.37.364.050	ZAHNSEGMENT LI. M6 300/360/380	GEAR SEGM. L/S M6 300/360/380	1
18	547.37.019.000	LAGERHÜLSE FÜR STEUERKLAPPE '97	BEAR. SLEEVE F.CONTROL FLAP '97	2
19	0770 150151	O-RING 15,00X1,50 SILICON	O-RING 15,00X1,50 SILICON	2
20*	546.37.020.700	STEUERKLAPPE „2503“ 250'98	CONTROL FLAP „2503“ 250'98	1
20*	546.37.320.700	STEUERKLAPPE „3003“ 300'98	CONTROL FLAP „3003“ 300'98	1
20*	547.37.020.200	STEUERKLAPPE „3603“ 380'98	CONTROL FLAP „3603“ 380'98	1
21	0912 060163	ISK.SCHRAUBE DIN0912-M 6X16	AH SCREW DIN0912-M 6X16	1
22	546.37.056.000	SCHEIBE 6,5X11X2 ALU	WASHER 6,5X11X2 ALU	1
23	0984 060063	ZYL.SCHRAUBE DIN7984-M 6X 6	AH SCREW DIN7984-M 6X 6	1
25	0015 050123	SK.BUNDSCHRAUBE M 5X12 SW=8	HH COLLAR SCREW M 5X12 WS=8	2
26	0349 000050	SCHEIBE DIN7349- 5X15X2	WASHER DIN7349- 5X15X2	2
27	546.35.005.000	WASSERPUMPENRAD	WATER PUMP WHEEL	1
28	0760 082472	WELLENDICHTRING 8X24X7 A-DUO	SHAFT SEAL RING 8X24X7 A-DUO	1
29	0137 060000	FEDERSCHEIBE DIN0137-B 6	SPRING WASHER DIN0137-B 6	X
30	0625 160026	RILLENKUGELLAGER 16002	BALL BEARING 16002	1

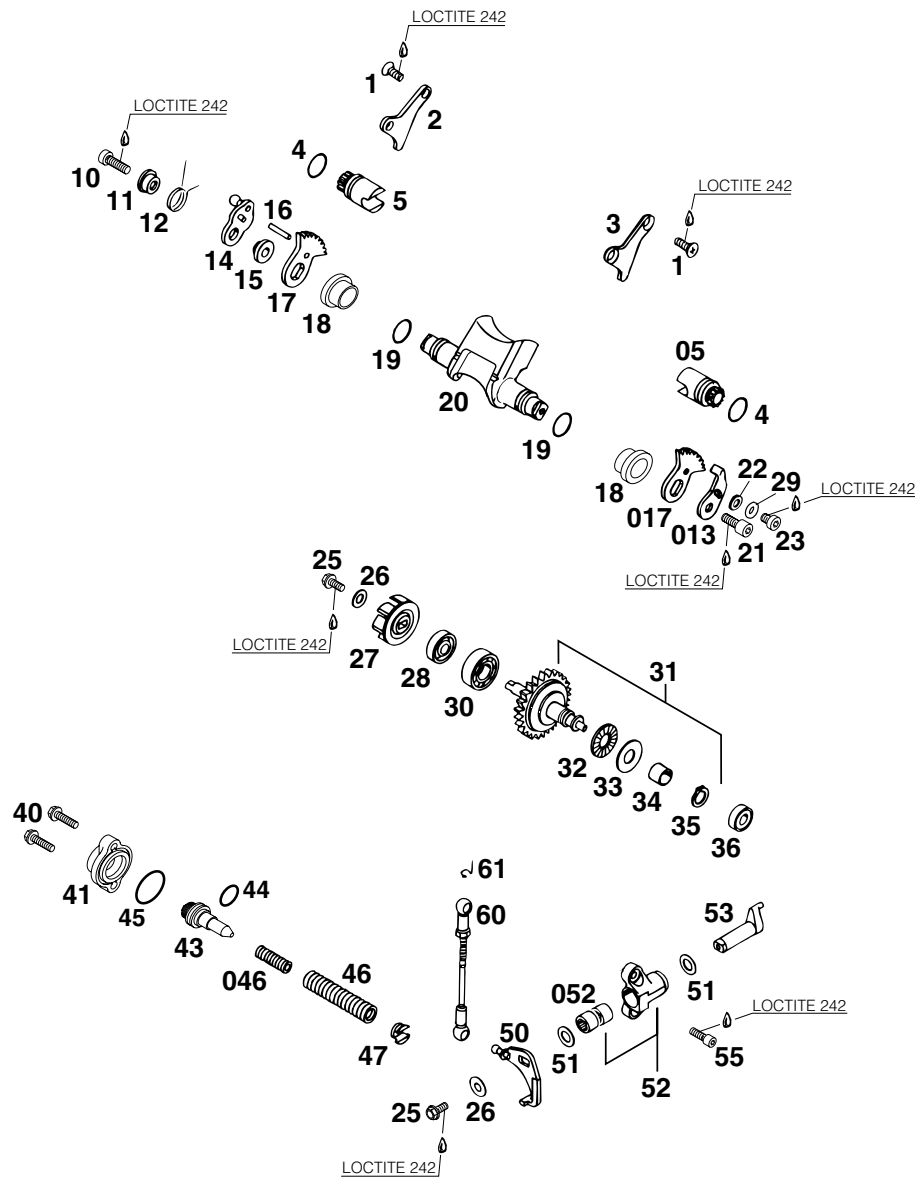

FIG	TEILNR./PARTNR	BEZEICHNUNG	DESCRIPTION	QTY
31	546.37.050.344	FLIEHKRAFTVERSTELLER KOMPLETT	CENTRIFUGAL TIMER CPL.	1
32	546.37.097.200	AXIALLAGER AXK 1226	AXIAL NEEDLE BEARING 1226 AXK	1
33	546.37.098.200	AXIALSCHEIBE AS1226 12X26X1	AXIAL WASHER AS1226 12X26X1	1
34	546.37.054.300	DISTANZRING 12X15X9	SPACER RING 12X15X9	1
35	0471 120010	SICHERUNGSRING DIN0471-12X1	CIRCLIP DIN0471-12X1	1
36	546.37.098.000	RILLENKUGELLAGER 626.2RS1.C3	GROOVED BALL BEAR. 626.2RS1.C3	1
40	0015 050203	SK.BUNDSCHRAUBE M 5X20 SW=8	HH COLLAR SCREW M 5X20 WS=8	2
41*	546.37.070.100	VERSCHLUSSDECKEL 250-380'98	COVER LID 250-380'98	1
43*	546.37.075.100	FEDERWIDERLAGER 250-380'98	SPRING GUIDE 250-380'98	1
44*	0770 021120	O-RING 12,37X2,62 NBR70	O-RING 12,37X2,62 NBR70	1
45*	0770 240020	O-RING 24,00X2,00 NBR70	O-RING 24,00X2,00 NBR70	1
46	546.37.072.100	EINSTELLFEDER '96	ADJUSTMENT SPRING '96	1
046	546.37.072.300	HILFSFEDER '95	AUXILIARY SPRING '95	1
47	546.37.071.200	FEDEREINSATZ '91	SPRING INSERT '91	1
50	546.37.055.244	WINKELHEBEL KPL. '91	ANGLE LEVER CPL. '91	1
51	0988 101610	PASSSCHEIBE DIN0988-10X16X1	SHIM WASHER DIN988 10X16X1,0	2
52	546.37.059.244	LAGERBOCK KPL.	BEARING SUPPORT CPL.	1
052	546.37.096.000	NADELHÜLSE HK 1010	NEEDLE SLEEVE HK 1010	2
53	546.37.057.200	VERSTELLHEBEL '91	CONTROL LEVER '91	1
55	0912 050163	ISK.SCHRAUBE DIN0912-M 5X16	AH SCREW DIN0912-M 5X16	2
60	546.37.095.344	GESTÄNGE KPL. 250/300/360/380	CONNECT.ROD 250/300/360/380	1
61	502.37.195.055	SICHERUNG FÜR KUGELGLENK M5	SECURING BALL JOINT M 5	2

ACHTUNG !!!
 Vor dem Einbau des Vergasers, Bedüsung kontrollieren.
CAUTION !!!
 Before mounting the carburetor, check the jetting.

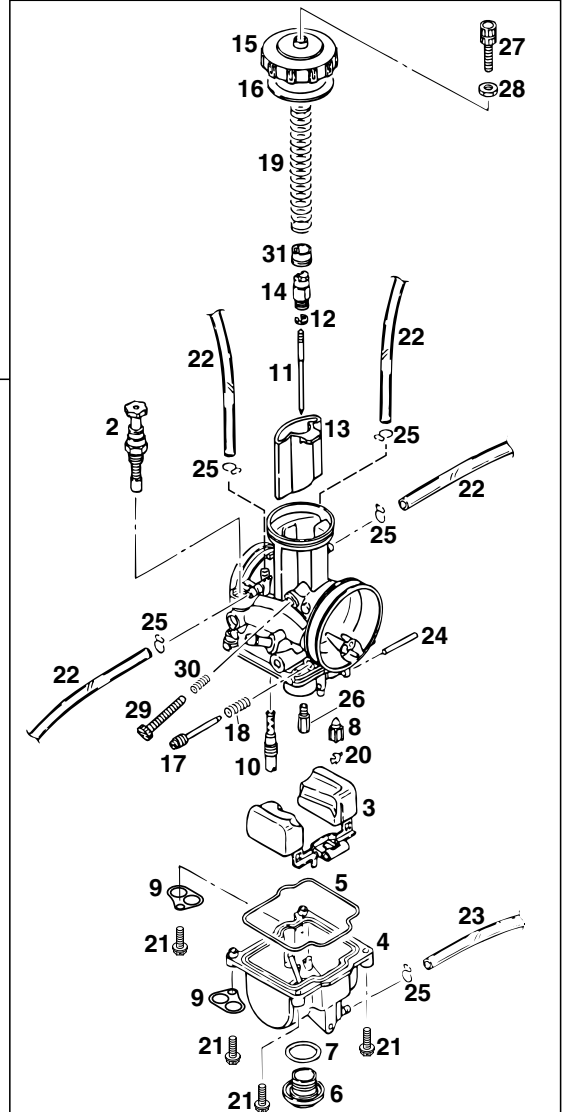

FIG	TEILNR/PARTNR	BEZEICHNUNG	DESCRIPTION	QTY
1	▲ 546.31.201.044	VERGASER KEIHIN PWK 38 '93 85 / 45 / 175 / N85D III	CARBURETOR KEIHIN PWK 38 '93 85 / 45 / 175 / N85D III	1
2	546.31.245.000	STARTKOLBEN KPL.	STARTER PISTON CPL.	1
3	546.31.209.000	SCHWIMMER R-39	FLOAT R-39	1
4	546.31.211.000	SCHWIMMERGEHÄUSE	FLOAT CHAMBER	1
5	545.31.610.000	DICHTUNG SCHWIMMERGEHÄUSE	GASKET FLOAT CHAMBER	1
6	545.31.699.000	VERSCHLUSSSCHRAUBE M18X1	PLUG M18X1 KEIHIN	1
7	0770 180230	O-RING 18,00X2,30 NBR 70	O-RING	1
8	546.31.220.000	SCHWIMMERNADEL	FLOAT NEEDLE 1062-814-2100	1
9	545.31.612.100	HALTEBLECH F. ENTLÜFTUNGSSCHL.	RETAINING PLATE FOR BLEEDER	2
10	545.31.607.035	LEERLAUFDÜSE GR.35 KEIHIN	IDLE JET 35 KEIHIN	X
10	545.31.607.038	LEERLAUFDÜSE GR.38 KEIHIN	IDLE JET 38 KEIHIN	X
10	545.31.607.040	LEERLAUFDÜSE GR.40 KEIHIN	IDLE JET 40 KEIHIN	X
10	545.31.607.042	LEERLAUFDÜSE GR.42 KEIHIN	IDLE JET 42 KEIHIN	X
10	545.31.607.045	LEERLAUFDÜSE GR.45 KEIHIN	IDLE JET 45 KEIHIN	1
10	545.31.607.048	LEERLAUFDÜSE GR.48 KEIHIN	IDLE JET 48 KEIHIN	X
10	545.31.607.050	LEERLAUFDÜSE GR.50 KEIHIN	IDLE JET 50 KEIHIN	X
10	545.31.607.052	LEERLAUFDÜSE GR.52 KEIHIN	IDLE JET 52 KEIHIN	X
10	545.31.607.054	LEERLAUFDÜSE GR.54 KEIHIN	IDLE JET 54 KEIHIN	X
10	545.31.607.055	LEERLAUFDÜSE GR.55 KEIHIN	IDLE JET 55 KEIHIN	X
10	545.31.607.058	LEERLAUFDÜSE GR.58 KEIHIN	IDLE JET 58 KEIHIN	X
10	545.31.607.060	LEERLAUFDÜSE GR.60 KEIHIN	IDLE JET 60 KEIHIN	X
10	545.31.607.062	LEERLAUFDÜSE GR.62 KEIHIN	IDLE JET 62 KEIHIN	X
10	545.31.607.065	LEERLAUFDÜSE GR.65 KEIHIN	IDLE JET 65 KEIHIN	X
10	545.31.607.070	LEERLAUFDÜSE GR.70 KEIHIN	IDLE JET 70 KEIHIN	X
10	545.31.607.075	LEERLAUFDÜSE GR.75 KEIHIN	IDLE JET 75 KEIHIN	X
10	545.31.607.080	LEERLAUFDÜSE GR.80 KEIHIN	IDLE JET 80 KEIHIN	X
11	545.31.636.851	DÜSENNADEL N 85 A KEIHIN	JET NEEDLE N 85 A KEIHIN	X
11	545.31.636.852	DÜSENNADEL N 85 B KEIHIN	JET NEEDLE N 85 B KEIHIN	X
11	545.31.636.853	DÜSENNADEL N 85 C KEIHIN	JET NEEDLE N 85 C KEIHIN	1
11	545.31.636.854	DÜSENNADEL N 85 D KEIHIN	JET NEEDLE N 85 D KEIHIN	1
11	545.31.636.855	DÜSENNADEL N 85 E KEIHIN	JET NEEDLE N 85 E KEIHIN	X
11	545.31.636.004	DÜSENNADEL NOZ D KEIHIN	JET NEEDLE NOZ D KEIHIN	X
11	545.31.636.005	DÜSENNADEL NOZ E KEIHIN	JET NEEDLE NOZ E KEIHIN	X
11	545.31.636.006	DÜSENNADEL NOZ F KEIHIN	JET NEEDLE NOZ F KEIHIN	X
11	545.31.636.007	DÜSENNADEL NOZ G KEIHIN	JET NEEDLE NOZ G KEIHIN	1
11	545.31.636.008	DÜSENNADEL NOZ H KEIHIN	JET NEEDLE NOZ H KEIHIN	1

ACHTUNG !!!
 Vor dem Einbau des Vergasers, Bedüsung kontrollieren.
CAUTION !!!
 Before mounting the carburetor, check the jetting.

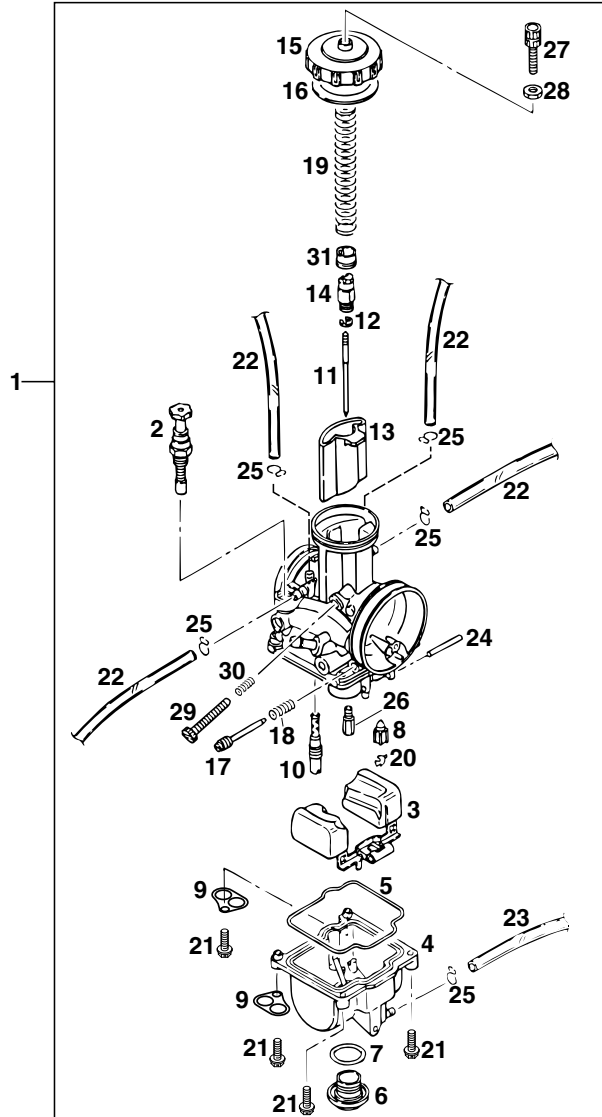

FIG	TEILNR/PARTNR	BEZEICHNUNG	DESCRIPTION	QTY
11	545.31.636.009	DÜSENNADEL NOZ I KEIHIN	JET NEEDLE NOZ I KEIHIN	X
12	545.31.629.000	KLEMMFEDER	CLIP FOR JET NEEDLE	1
13	546.31.235.006	GASSCHIEBER 6	THROTTLE VALVE 6	1
14	546.31.232.000	NIPPEL	NIPPLE 1101-804-2001	1
15	546.31.227.000	VERGASERDECKEL	CARBURETOR COVER	1
16	545.31.628.000	GUMMIDICHTRING 40X46X1	RUBBER SEAL RING 40X46X1	1
17	545.31.617.000	STELLSCHRAUBE	ADJUSTMENT SCREW	1
18	545.31.615.000	FEDER FÜR STELSCHRAUBE	SPRING FOR ADJUSTMENT SCREW	1
19	546.31.230.000	SCHIEBERFEDER	SLIDING SPRING	1
20	545.31.621.000	KLAMMER	CLAMP	1
21	0016 040163	SK.BUNDSCHRAUBE M 4X16 SW=6	HH COLLAR SCREW M4X16 SW6	4
22	310.07.007.001	PVC-SCHLAUCH 5 X 8 MM	PVC-HOSE 5 X 8 MM	1,92
23	520.31.137.001	PVC-SCHLAUCH 3 X 6 MM	PVC-HOSE 3 X 6 MM	0,39
24	545.31.608.000	STIFT 2,5X25	STUD 2,5X25	1
25	545.31.696.000	KLAMMER 6 MM	CLAMP 6 MM	X
26	545.31.623.150	HAUPTDÜSE GR.150 KEIHIN	MAIN JET 150 KEIHIN	X
26	545.31.623.158	HAUPTDÜSE GR.158 KEIHIN	MAIN JET 158 KEIHIN	X
26	545.31.623.160	HAUPTDÜSE GR.160 KEIHIN	MAIN JET 160 KEIHIN	X
26	545.31.623.165	HAUPTDÜSE GR.165 KEIHIN	MAIN JET 165 KEIHIN	X
26	545.31.623.170	HAUPTDÜSE GR.170 KEIHIN	MAIN JET 170 KEIHIN	X
26	545.31.623.172	HAUPTDÜSE GR.172 KEIHIN	MAIN JET 172 KEIHIN	X
26	545.31.623.175	HAUPTDÜSE GR.175 KEIHIN	MAIN JET 175 KEIHIN	1
26	545.31.623.178	HAUPTDÜSE GR.178 KEIHIN	MAIN JET 178 KEIHIN	X
26	545.31.623.180	HAUPTDÜSE GR.180 KEIHIN	MAIN JET 180 KEIHIN	X
26	545.31.623.182	HAUPTDÜSE GR.182 KEIHIN	MAIN JET 182 KEIHIN	X
26	545.31.623.185	HAUPTDÜSE GR.185 KEIHIN	MAIN JET 185 KEIHIN	X
26	545.31.623.188	HAUPTDÜSE GR.188 KEIHIN	MAIN JET 180 KEIHIN	X
26	545.31.623.190	HAUPTDÜSE GR.190 KEIHIN	MAIN JET 190 KEIHIN	X
26	545.31.623.195	HAUPTDÜSE GR.195 KEIHIN	MAIN JET 195 KEIHIN	X
27	545.31.625.000	STELLSCHRAUBE M6X0,75	ADJUSTMENT SCREW M6X0,75	1
28	520.31.126.000	SK.MUTTER M6X0,75 DIN0439	HEXAGON NUT M6X0,75 DIN0439	1
29	546.31.219.100	STELLSCHRAUBE M5	ADJUSTMENT SCREW M5	1
30	546.31.118.000	FEDER	SPRING	1
31	546.31.231.000	FEDERTASSE	SPRING CAP	1
32*	503.31.029.031	SCHIEBERANSCHLAG L=31MM	SLIDE STOP L=31MM	X
33*	503.31.029.036	SCHIEBERANSCHLAG L=36MM	SLIDE STOP L=36MM	X
34*	0770 060020	O-RING 6,00X2,00 NBR 70	O-RING 6,00X2,00 NBR 70	X

* = NEUTEIL / NEW PART X = NACH BEDARF / AS REQUIRED

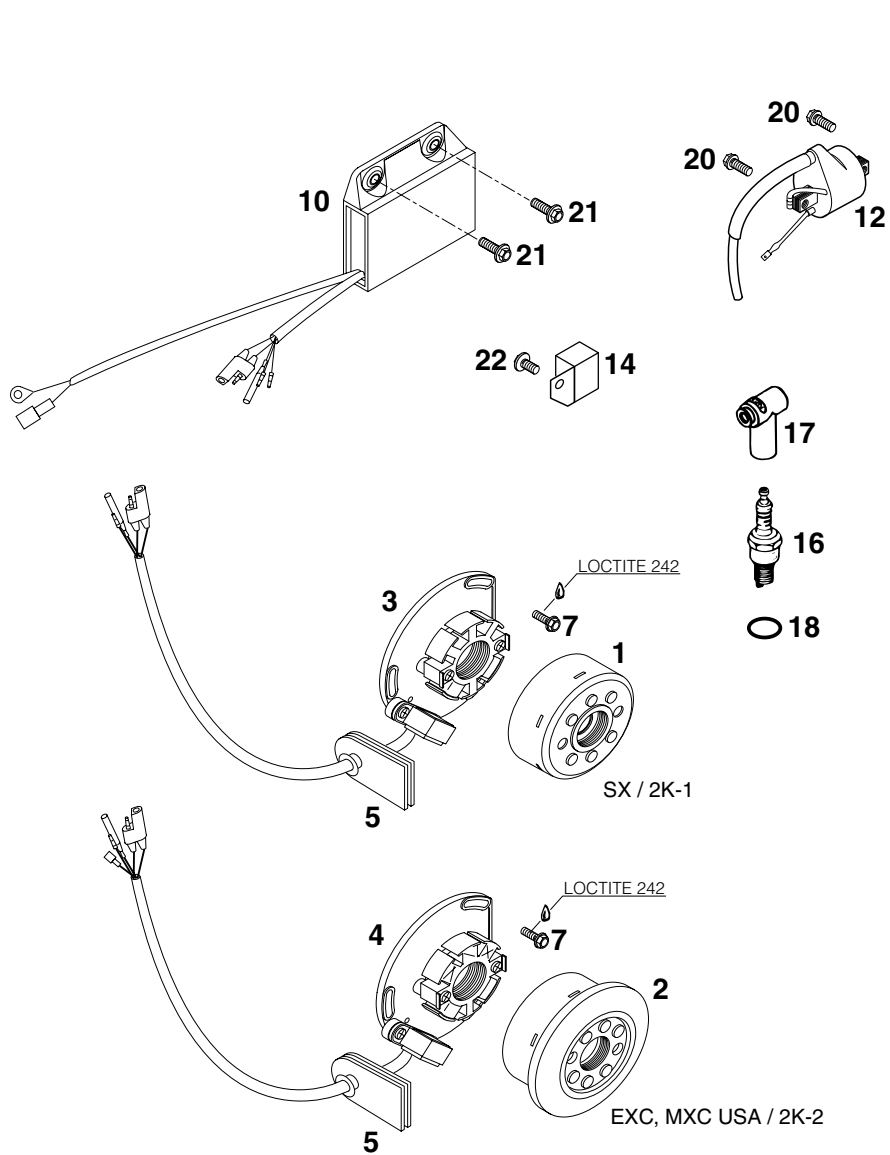
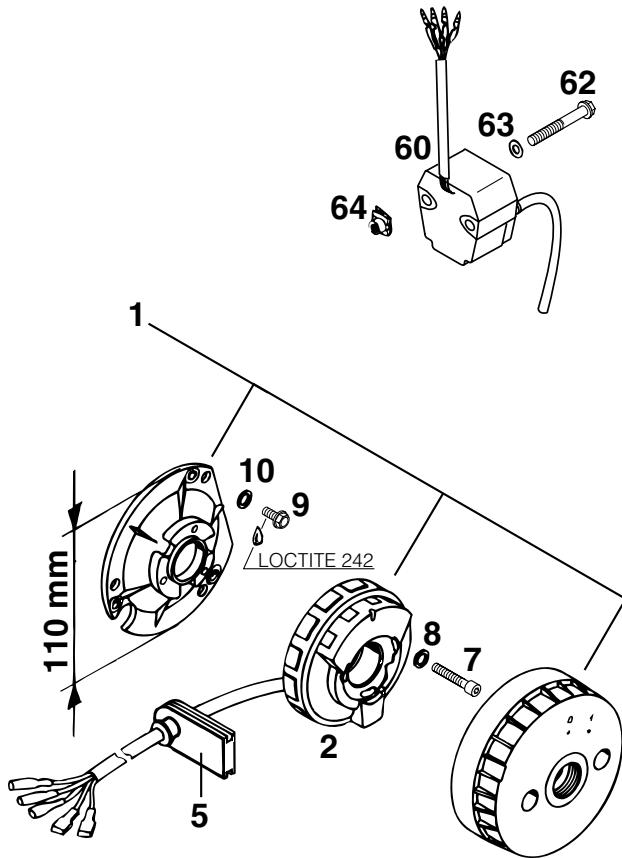

FIG	TEILNR/PARTNR	BEZEICHNUNG	DESCRIPTION	QTY
1	547.39.005.000	ROTOR KOKUSAN 2K-1 '97	FLYWHEEL KOKUSAN 2K-1 '97	1
2	547.39.005.144	ROTOR KOKUSAN 2K-2 KPL. '97	FLYWHEEL KOKUSAN 2K-2 CPL. '97	1
3	547.39.004.000	STATOR KOKUSAN 2K-1 '97 250/380 SX	STATOR KOKUSAN 2K-1 '97 250/380 SX	1
4	547.39.004.100	STATOR KOKUSAN 2K-2 '97 250/300/380 MXC,EXC USA	STATOR KOKUSAN 2K-2 '97 250/300/380 MXC,EXC USA	1
5	546.31.004.300	GUMMIDURCHFÜHRUNG	RUBBER PASSAGE	1
7	0015 050163	SK.BUNDSCHRAUBE M 5X16 SW=8	HH COLLAR SCREW M 5X16 WS=8	3
10	546.39.031.100	DIGITALBOX KOKUSAN 250SX/EXC 250 SX EU/USA,250 MXC/EXC USA	DIGITAL BOX KOKUSAN '97 250 SX EU/USA.250 MXC/EXC USA	1
10*	547.39.031.200	DIGITALBOX KOKUSAN '98 300/380 SX/MXC/EXC USA, SX EU	DIGITAL BOX KOKUSAN '98 300/380 SX/MXC/EXC USA, SX EU	1
12*	503.39.006.000	ZÜNDSPULE KOKUSAN 125-380 '98	IGNITION COIL KOKU. 125-380'98	1
14	547.11.034.000	SPANNUNGSREGLER KOKUSAN EXC 250/300/380 EXC USA	VOLTAGE REGULATOR KOKUSAN EXC 250/300/380 EXC USA	1
16	543.31.093.410	ZÜNDKERZE NGK BR8ECM	SPARK PLUG NGK BR8ECM	1
17	545.31.010.000	KERZENSTECKER LB05EMH NGK	SPARK PLUG CAP LB05EMH NGK	1
18	0770 150040	O-RING 15,00X4,00 NBR 70	O-RING 15,00X4,00 NBR 70	1
20	0015 060163	SK.BUNDSCHRAUBE M 6X16 SW=8	HH COLLAR SCREW M 6X16 WS=8	2
21	0014 060203	SK.BUNDSCHRAUBE M 6X20 SW=8	HH COLLAR SCREW M 6X20 WS=8	2
22	0014 060103	SK.BUNDSCHRAUBE M 6X10 SW=8	HH COLLAR SCREW M 6X10 WS=8	1

FIG	TEILNR/PARTNR	BEZEICHNUNG	DESCRIPTION	QTY
1	546.31.602.300	ZÜNDANLAGE K11 KPL. '92	IGNITION K11 CPL. '92	1
2	546.31.602.351	STATOR LOSE „19“	STATOR LOOSE „19“	1
5	546.31.004.300	GUMMIDURCHFÜHRUNG	RUBBER PASSAGE	1
7	0912 050303	ISK.SCHRAUBE DIN0912-M 5X30	AH SCREW DIN0912-M 5X30	3
8	0125 050003	UNTERLEGSCHIEBE DIN0125-A 5,0	WASHER DIN0125-A 5,0	3
9	0015 050123	SK.BUNDSCHRAUBE M 5X12 SW=8	HH COLLAR SCREW M 5X12 WS=8	3
10	0125 050003	UNTERLEGSCHIEBE DIN0125-A 5,0	WASHER DIN0125-A 5,0	3
12	0770 150040	O-RING 15,00X4,00 NBR 70	O-RING 15,00X4,00 NBR 70	1
31	545.31.010.000	KERZENSTECKER LB05EMH NGK	SPARK PLUG CAP LB05EMH NGK	1
60	546.31.606.100	ZÜNDMODUL TM 14-07	IGNITION MODUL TM 14-07	1
62	0015 060453	SK.BUNDSCHRAUBE M 6X45 SW=8	HH COLLAR SCREW M 6X45 WS=8	2
63	0125 060003	UNTERLEGSCHIEBE DIN0125-A 6,4	WASHER DIN0125-A 6,4	2
64	502.35.033.300	KLIPS-MUTTERNHALTER M6 KP142	SNAP-NUT HOLDER M6 KP142	2
93	543.31.093.410	ZÜNDKERZE NGK BR8ECM	SPARK PLUG NGK BR8ECM	1



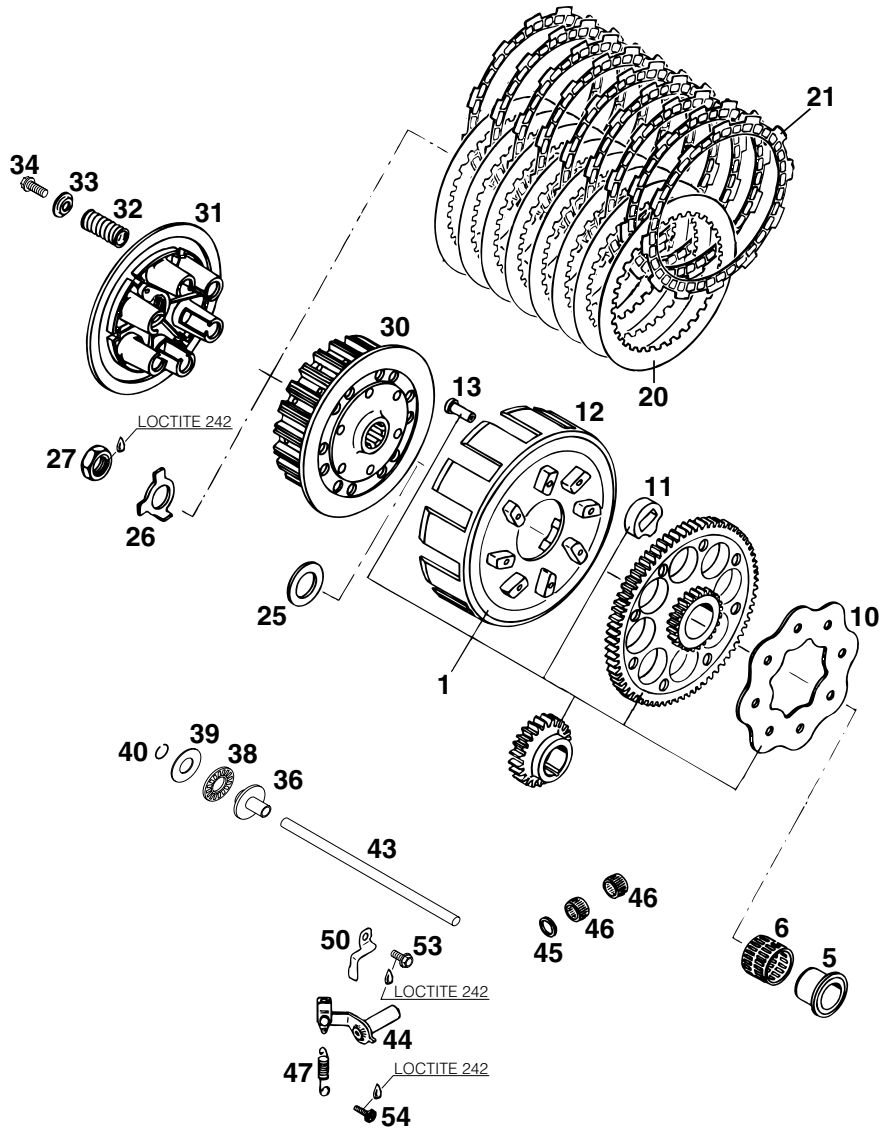

FIG	TEILNR./PARTNR	BEZEICHNUNG	DESCRIPTION	QTY
1	546.32.001.272	KUPPLUNGSKORB 72-Z M.PRIM.25-Z 250/300 CC	OUTER CLUTCH HUB 72T PRIM. 25T 250/300 CC	1
1	546.32.001.372	KUPPLUNGSKORB 72-Z M.PRIM.26-Z 380 CC	OUTER CLUTCH HUB 72T PRIM. 26T 380 CC	1
5	503.32.070.000	INNENRING MIT BUND	INNER RING WITH COLLAR	1
6	565.32.095.000	NADELKRANZ K 26X30X22 ZW.KSE	NEEDLE BEARING K26X30X22ZW.KSE	1
10	581.32.028.000	HALTEBLECH	RETAINING PLATE	1
11	581.32.026.000	DÄMPFERELEMENT	DAMPING ELEMENT	8
12	546.32.001.200	KUPPLUNGSKORB LOSE	OUTER CLUTCH HUB LOOSE	1
13	0733 060150	KUPPLUNGSNIET DIN7338- 6X15	CLUTCH RIVET DIN7338- 6X15	8
20	546.32.012.000	STAHLLELLE 1,2 MM	STEEL DISK 1,2 MM	8
21	546.32.011.300	BELAGLELLE 2,7 MM '96	LINING DISK 2,7 MM '96	9
25	575.32.013.000	STÜTZSCHEIBE 22,2X35X3 GEHÄRT.	SUPPORTWASHER 22,2X35X3 HARDE.	1
26	565.32.018.000	SICHERUNGSBLECH	LOCK WASHER	1
27	0936 181505	SK.MUTTER DIN0936-M18X1,5	HEXAGON NUT DIN0936-M18X1,5	1
30	546.32.002.200	MITNEHMER	INNER CLUTCH HUB	1
31*	581.32.003.200	DRUCKKAPPE '98	PRESSURE PLATE '98	1
32	546.32.080.000	KUPPLUNGSFEDER 2,5X43 8,5W	CLUTCH SPRING 2,5X43 8,5W	6
33	581.32.081.000	FEDERTELLER 6,2 X 20 X 3,2	SPRING RETAINER 6,2 X 20 X 3,2	6
34	0015 060163	SK.BUNDSCHRAUBE M 6X16 SW=8	HH COLLAR SCREW M 6X16 WS=8	6
36*	503.32.054.051	DRUCKPILZ 125-380 '98	PRESSURE PIECE 125-380 '98	1
38*	546.37.097.200	AXIALLAGER AXK 1226	AXIAL NEEDLE BEARING 1226 AXK	1
39*	546.37.098.200	AXIALSCHEIBE AS1226 12X26X1	AXIAL WASHER AS1226 12X26X1	1
39*	546.37.098.300	AXIALSCHEIBE 12,5X25,8X1,5	AXIAL WASHER AS1226 12X26X1,5	X
40*	0993 012000	SPRENGRING DIN7993-RW12	CIRCLIP DIN7993A-RW12	1
43*	546.32.054.000	DRUCKSTANGE L=216MM D=7MM '98	PUSH ROD L=216MM D=7MM '98	1
44	546.32.014.544	AUSRÜCKWELLE '93	CLUTCH RELEASE SHAFT '93	1
45	546.32.090.000	DICHTRING DH/GR 12X16X3	SEAL RING DH/GR 12X16X3	1
46	502.32.095.000	NADELHÜLSE HK 1210	NEEDLE BEARING HK 1210	2
47	546.32.050.500	AUSRÜCKHEBELFEDER L=33MM '93	RELEASE LEVER SPRING L=33MM'93	1
50	546.32.016.500	AUSRÜCKHALTEBLECH '93	RELEASE RETAINING PLATE '93	1
53	0015 050123	SK.BUNDSCHRAUBE M 5X12 SW=8	HH COLLAR SCREW M 5X12 WS=8	1
54	0985 050103	LINSENSCHRAUBE DIN7985-M 5X10	OVAL HEAD SCR. DIN7985-M 5X10	1

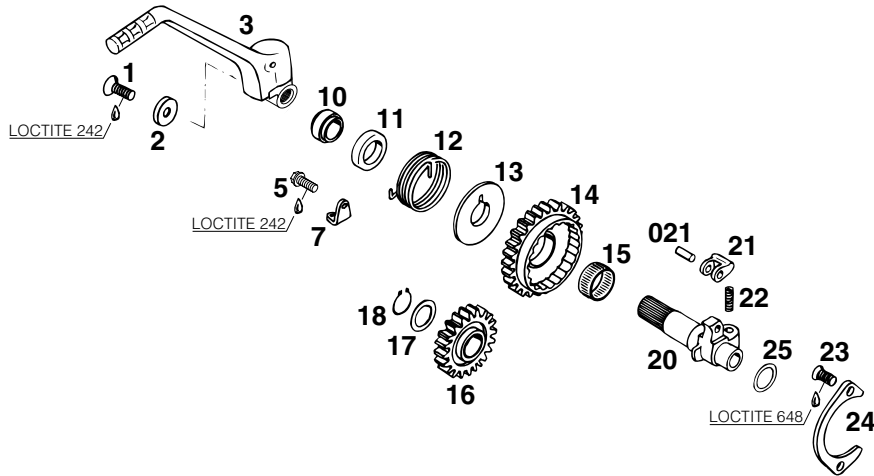

FIG	TEILNR/PARTNR	BEZEICHNUNG	DESCRIPTION	QTY
1	546.10.052.000	KETTENRADSCHRAUBE-ISK M 8X20	SPROCKET SCREW-AH M 8X20	1
2	546.33.037.000	FASSONSCHLEIBE 8 MM	WASHER D=8MM	1
3*	547.33.070.044	KICKSTARTER KPL. 250-380 '98	KICKSTARTER CPL. 250-380 '98	1
3	546.33.036.344	KICKSTARTER KPL 250/VI '92	KICKSTARTER CPL.250 VI '92	X
5	0015 060163	SK.BUNDSCHRAUBE M 6X16 SW=8	HH COLLAR SCREW M 6X16 WS=8	1
7	546.33.074.000	FEDERLASCH	SPRING HANGER	1
10	546.33.038.000	DISTANZBÜCHSE	SPACER BUSHING ZINC PLATED	1
11	0760 193070	WELLENDICHTRING 19X30X7 B	SHAFT SEAL RING 19X30X7B	1
12	546.33.025.000	KICKSTARTERFEDER	KICKSTARTER SPRING	1
13	546.33.026.000	MITNEHMERNABE	DRIVING HUB	1
14	546.33.022.000	STARTERRAD 34 Z MODUL 2	KICKSTARTER GEAR 34 T MODUL 2	1
15	565.33.098.000	NADELKRANZ K 22 X 26 X 13 H	NEEDLE BEARING K 22 X 26 X 13	1
16	546.33.024.200	STARTERZWISCHENRAD 24 Z	KICKST.INTERMEDIATE GEAR 24 T	1
17	546.33.090.000	ANLAUFSCHLEIBE 17,2X25X1	STOP DISK 17,2X24X1	1
18	0471 170010	SICHERUNGSRING DIN0471-17X1	CIRCLIP DIN0471-17X1	1
20	546.33.021.200	KICKSTARTERWELLE	KICKSTARTER SHAFT	1
021	0402 061480	NADELROLLE DIN5402 NRB 6X14,8	NEEDLE ROLLER DIN5402 6X14,8	1
21	546.33.023.200	SPERRKLINKE	LOCKING PAWL	1
22	546.33.028.200	KLINKENFEDER	RATCHET SPRING	1
23	0991 060122	SENKSCHRAUBE DIN7991-M 6X12	FLAT HEAD SCREW DIN7991-M 6X12	2
24	546.33.027.000	AUSRÜCKBLECH	RELEASE PLATE	1
25	0988 172405	PASSSCHLEIBE DIN0988-17X24X0,5	SHIM WASHER DIN0988-17X24X0,5	1

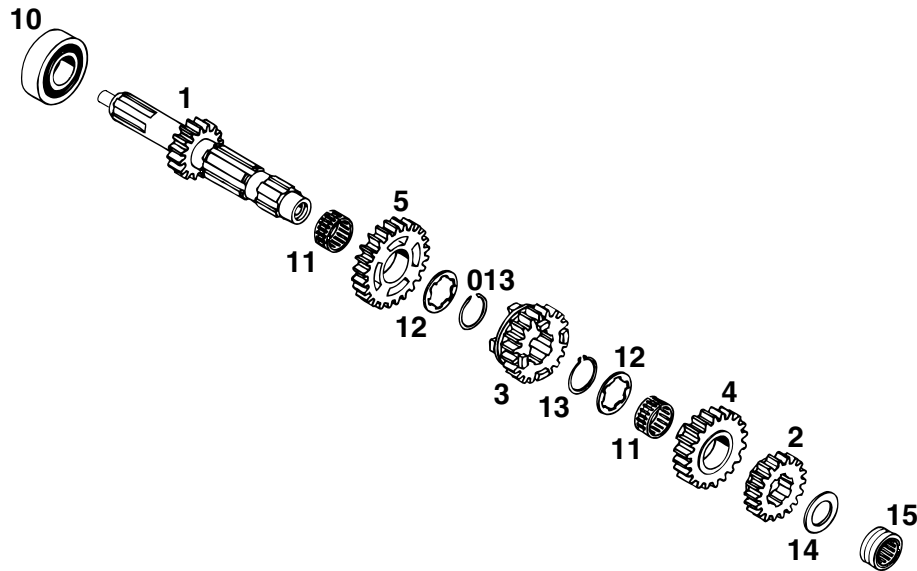

FIG	TEILNR/PARTNR	BEZEICHNUNG	DESCRIPTION	QTY
1*	546.33.002.500	ANTRIEBSWELLE 15-Z '98	MAIN SHAFT 15-T '98	1
2	546.33.010.000	FESTRAD 2.G 17-Z SX 250 „440“ 250 SX/MXC	2ND GEAR MAINSHAFT 17-T „440“ 250 SX/MXC	1
2	546.33.110.000	FESTRAD 2.G 18-Z SX/GS „445“ 250-380 EXC/EGS, 380 SX	2ND GEAR MAINSHAFT 18-T „445“ 300/380 MXC	1
3	546.33.006.300	SCHIEBERAD 3.G 19-Z SX „462“ 250/380 SX, 250/300/380 MXC	3RD GEAR MAINSHAFT 19-T „462“ 250/380 SX, 250/300/380 MXC	1
3	546.33.106.300	SCHIEBERAD 3.G 19-Z GS „467“ 250-380 EXC,EGS	3RD GEAR MAINSHAFT 19-T „467“ 250-380 EXC,EGS	1
4	546.33.008.000	LOSRAD 4.G 21-Z SX „480“ 250/380 SX, 250/300/380 MXC	4TH GEAR MAINSHAFT 21-T „480“ 250/380 SX, 250/300/380 MXC	1
4	546.33.108.000	LOSRAD 4.G 21-Z GS „485“ 250-380 EXC,EGS	4TH GEAR MAINSHAFT 21-T „485“ 250-380 EXC,EGS	1
5	546.33.004.000	LOSRAD 5.G 23-Z SX „500“ 250/380 SX, 250/300/380 MXC	5TH GEAR MAINSHAFT 23-T „500“ 250/380 SX, 250/300/380 MXC	1
5	546.33.104.000	LOSRAD 5.G 23-Z GS „505“ 250-380 EXC,EGS	5TH GEAR MAINSHAFT 23-T „505“ 250-380 EXC,EGS	1
10	0625 201029	RILLENKUGELLAGER 201029 C4	BALL BEARING 201029 C4	1
11	565.33.099.000	NADELKRANZ K22X26X13 GETEILT	NEEDLE BEAR. K22X26X13 DIVIDED	2
12	546.33.016.000	ANLAUFSCHIEBE 22,4X25,7X32X1,5	STOP DISK 22,5X25,7X32X1,5	2
13	520.33.096.000	SICH.RING DIN0471-25X1,64SD	LOCK RING DIN0471-25X1,64SD	1
013	546.33.096.000	AXIALSICHERUNG 25X1,64	AXIAL-CIRCLIP 25X1,64	1
14	546.33.015.000	ANLAUFSCHIEBE 20,2X33X1,5	STOP DISK 20,2X33X1,5	1
15	565.33.093.000	NADELLAGER RNA 4902 KSE	NEEDLE BEARING RNA 4902 KSE	1

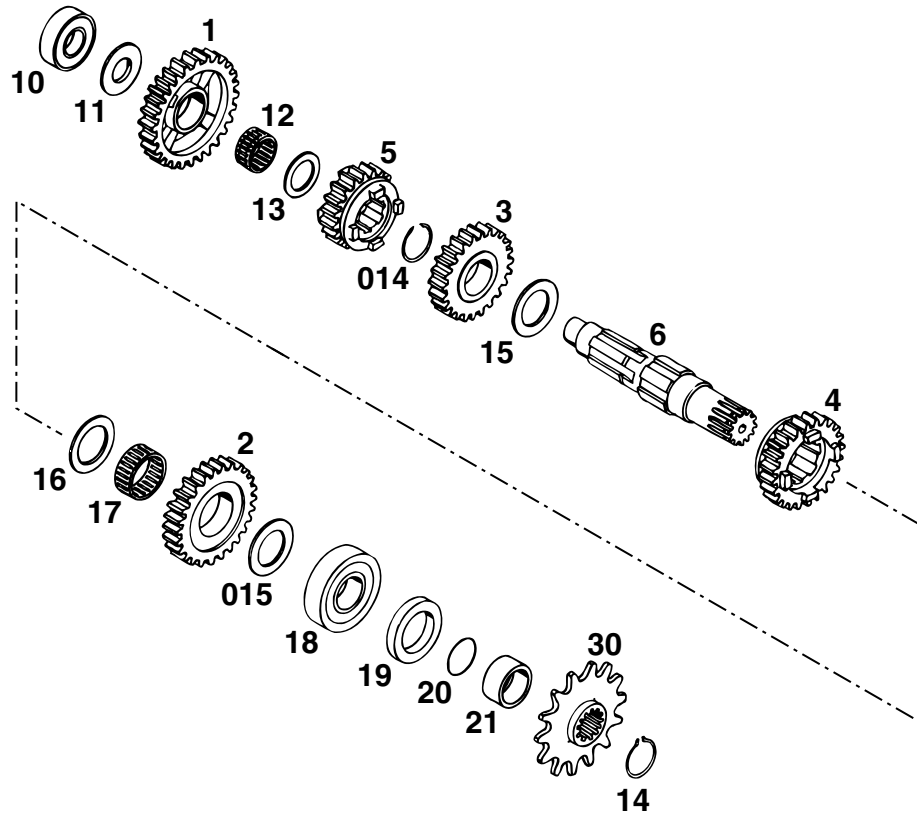

FIG	TEILNR/PARTNR	BEZEICHNUNG	DESCRIPTION	QTY
1	546.33.005.000	LOS RAD 1.G 29-Z SX/GS „430“	1ST GEAR COUNTERSH.29-T „430“	1
2	546.33.013.000	LOS RAD 2.G 27-Z SX 250 „450“ 250 SX/MXC	2ND GEAR COUNTERSH.27-T „450“ 250 SX/MXC	1
2	546.33.113.000	LOS RAD 2.G 26-Z „455“ 250-380 EXC/EGS, 380 SX	2ND GEAR COUNTERSH.26-T „455“ 300/380 MXC	1
3	546.33.009.000	LOS RAD 3.G 25-Z SX 250 „470“ 250 SX/MXC	3RD GEAR COUNTERSH.25-T „470“ 250 SX/MXC	1
3	546.33.009.100	LOS RAD 3.G 24-Z SX „472“ 380 SX, 300/380 MXC	3RD GEAR COUNTERSH.24 T „472“ 380 SX, 300/380 MXC	1
3	546.33.109.000	LOS RAD 3.G 22-Z GS „475“ 250-380 EXC,EGS	3RD GEAR COUNTERSH.22-T „475“ 250-380 EXC,EGS	1
4	546.33.011.000	SCHIEBERAD 4.G 23-Z SX „490“ 250/380 SX, 250/300/380 MXC	4TH GEAR COUNTERSH.23-T „490“ 250/380 SX, 250/300/380 MXC	1
4	546.33.111.000	SCHIEBERAD 4.G 20-Z GS „495“ 250-380 EXC,EGS	4TH GEAR COUNTERSH.20-T „495“ 250-380 EXC,EGS	1
5	546.33.007.300	SCHIEBERAD 5.G 21-Z SX „512“ 250/380 SX, 250/300/380 MXC	5TH GEAR COUNTERSH.21-T „512“ 250/380 SX, 250/300/380 MXC	1
5	546.33.107.300	SCHIEBERAD 5.G 18-Z GS „517“ 250-380 EXC,EGS	5TH GEAR COUNTERSH.18-T „517“ 250-380 EXC,EGS	1
6	546.33.003.400	ABTRIEBSWELLE '93	COUNTER SHAFT '93	1
10	0625 062031	RILLENKUGELLAGER 6203 TN9.C3	BALL BEARING 6203 TN9.C3	1
11	546.33.018.000	ANLAUFSCHIEBE 17,2X34X1,5	STOP DISK 17,2X34X1,5	1
12	565.33.099.000	NADELKRANZ K22X26X13 GETEILT	NEEDLE BEAR. K22X26X13 DIVIDED	1
13	546.33.017.000	ANLAUFSCHIEBE 22,2X33X1,5	STOP DISK 22,2X33X1,5	1
14	520.33.096.000	SICH.RING DIN0471-25X1,64SD	LOCK RING DIN0471-25X1,64SD	1
014	546.33.196.000	AXIALSICHERUNG 25X2,0	AXIAL CIRCLIP 25X2,0	1
15	546.33.020.400	ANLAUFSCHIEBE 26X40X1,5	STOP DISK 26X40X1,5	1
015	546.33.020.000	ANLAUFSCHIEBE 25,7X40X1,5	STOP DISK 25,2X40X1,5	1
16	546.33.019.000	ANLAUFSCHIEBE 28,2X40X1,5	STOP DISK 28,2X42X1,5	1
17	546.33.098.000	NADELKRANZ K 28X33X13 FV	NEEDLE BEARING K 28X33X13 FV	1
18	0625 613742	RILLENKUGELLAGER 613742 C4	BALL BEARING 613742 C4	1
19	0760 324271	WELLENDICHRING 32X42X7 BSL	SHAFT SEAL RING 32X42X7 BSL	1
20	0770 250020	O-RING 25,00X2,00 NBR 70	O-RING 25,00X2,00 NBR 70	1
21	546.33.014.100	DISTANZBÜCHSE 12MM	SPACER BUSHING 12 MM	1
30	500.33.029.013	KETTENRAD 13-Z	SPROCKET 13-T	1
30	500.33.029.014	KETTENRAD 14-Z	SPROCKET 14-T	1
30	500.33.029.015	KETTENRAD 15-Z	SPROCKET 15-T	1

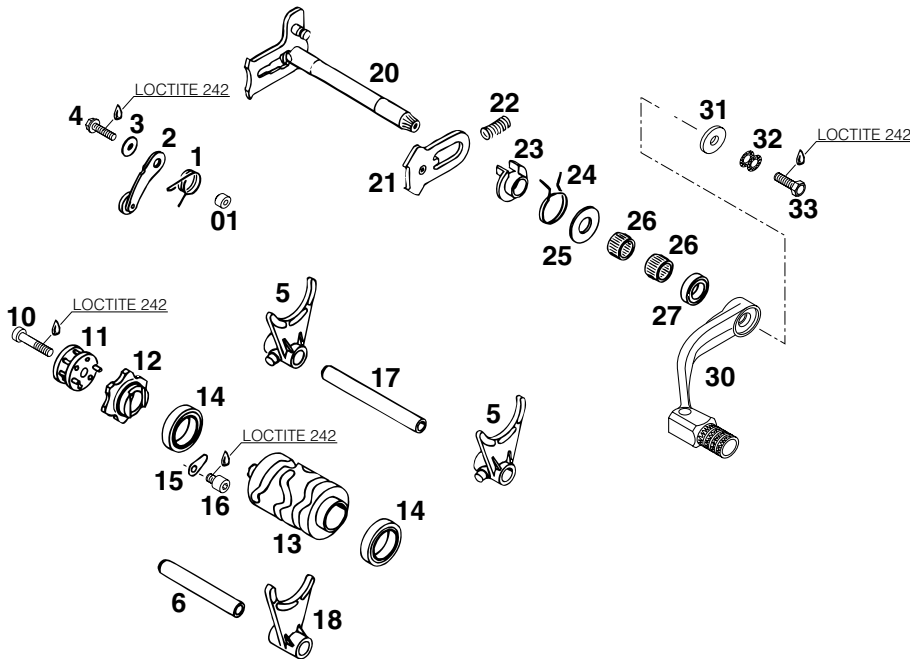

FIG	TEILNR/PARTNR	BEZEICHNUNG	DESCRIPTION	QTY
1	546.34.023.300	ARRETIERHEBELFEDER '96	LOCKING LEVER SPRING D=2,3MM96	1
01	546.34.052.300	HÜLSE FÜR ARRETIERHEBEL	SLEEVE FOR LOCKING LEVER	1
2	546.34.024.144	ARRETIERHEBEL KPL. '96	LOCKING LEVER CPL '96	1
3	0021 050003	SCHEIBE DIN9021-A 5,3	WASHER DIN9021-A 5,3	1
4	0015 050203	SK.BUNDSCHRAUBE M 5X20 SW=8	HH COLLAR SCREW M 5X20 WS=8	1
5	546.34.002.100	SCHALTGABEL 1./3.GANG + 2.G.	SHIFTING FORK 1ST/3RD GEAR+2ND	2
6	546.34.003.000	SCHALTSCHIENE ANTRIEBSWELLE	SHIFTING RAIL CRANKSHAFT	1
10	0984 060300	ZYL.SCHRAUBE DIN7984-M 6X30	AH SCREW DIN6912 M6X30	1
11	546.34.013.044	WALZENMITNEHMER KPL.MIT NADELN	DRIVER F.SHIFT ROLLER W.NEEDLE	1
12	546.34.015.000	WALZENARRETIERUNG	LOCKING ROLLER	1
13	546.34.012.400	SCHALTWALZE ALU 250/300/360'95	SHIFTROLLER ALU 250/300/360'95	1
14	0625 618050	RILLENKUGELLAGER 61805 C3	BALL BEARING 61805 C3	2
15	546.34.049.000	HALTEBLECH	RETAINING PLATE	2
16	0912 060083	ISK.SCHRAUBE DIN0912-M 6X 8	AH SCREW DIN0912-M 6X 8	2
17	546.34.004.000	SCHALTSCHIENE ABTRIEBSWELLE	SHIFTING RAIL CRANKSHAFT	1
18	546.34.001.100	SCHALTGABEL 4./5. GANG	SHIFTING FORK 4TH/6TH GEAR	1
20	546.34.005.044	SCHALTWELLE	SHIFTING SHAFT CPL	1
21	546.34.008.000	GLEITBLECH	SLIDING PLATE	1
22	565.34.013.100	SPANNFEDER 0,8MM	SPANNER SPRING 0,8MM	1
23	546.34.020.000	FEDERFÜHRUNG	SPRING GUIDE	1
24	546.34.014.100	RÜCKHOLFEDER 2,2MM '95	RETURN SPRING 2,2MM '95	1
25	546.34.050.000	ANLAUFSCHLEIBE 14X30X1	STOP DISK 14X30X1	1
26	546.32.095.000	NADELHÜLSE HK 1412	NEEDLE BEAR.HK 1412 14,6X20X12	2
27	0760 142460	WELLENDICHTRING 14X24X6 B	SHAFT SEAL RING 14X24X6 B	1
30	546.34.031.044	SCHALTHEBEL KPL. 2-TAKT	SHIFT LEVER CPL. 2-STROKE	1
31	502.32.050.001	STAHSCHLEIBE 6X17X3	STEEL WASHER 6X17X3	1
32	502.33.041.000	NORDLOCK SCHEIBEN M6 (PAAR)	PAIR OF WASHERS M6 NORDLOCK	1
33	0933 060203	SK.SCHRAUBE DIN0933-M 6X20	HH SCREW DIN0933-M 6X20	1

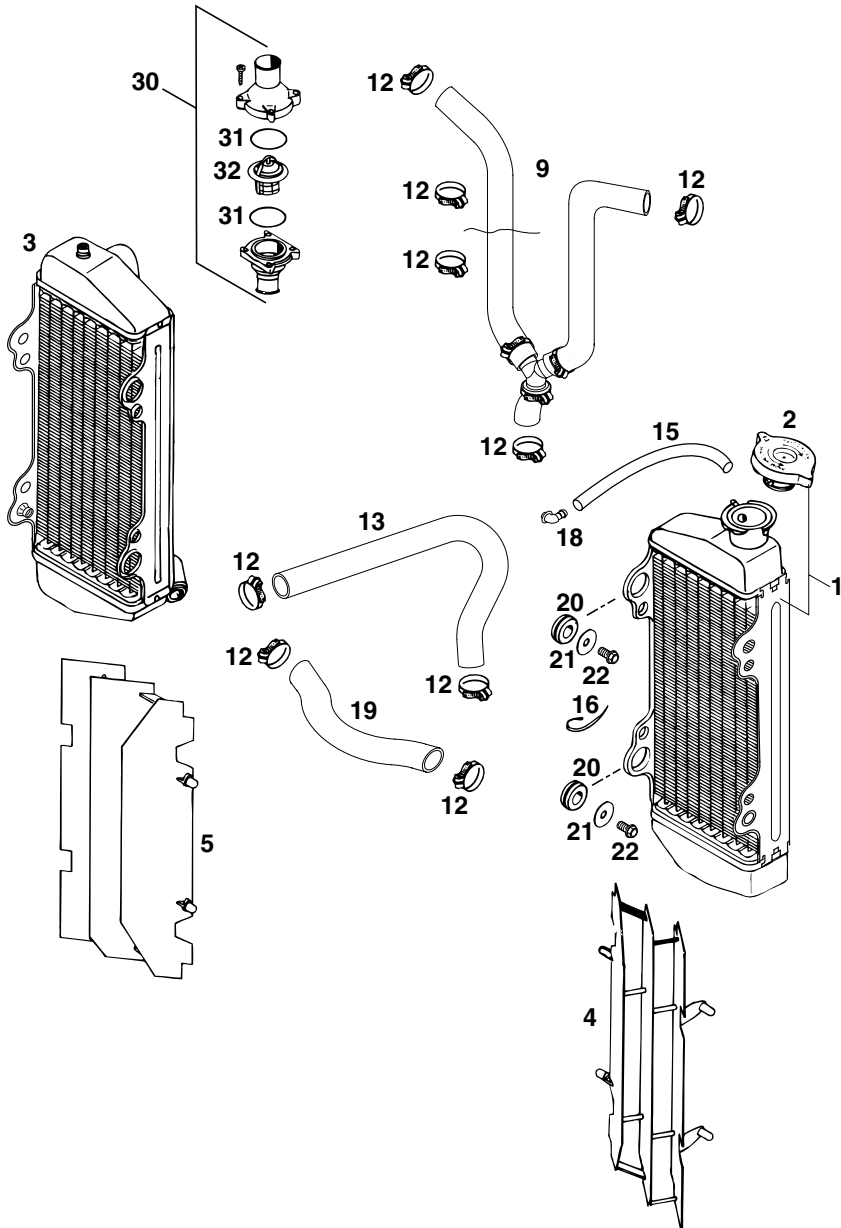

FIG	TEILNR/PARTNR	BEZEICHNUNG	DESCRIPTION	QTY
1*	503.35.007.000	KÜHLER LINKS NATUR (45286) '98	RADIATOR L/S NATURE (45286)'98	1
2	580.35.016.000	KÜHLERVERSCHLUSS KLEIN 1,4 BAR	RADIATOR CAP SMALL 1,4 BAR	1
3*	547.35.008.000	KÜHLER RECHTS NATUR (45287)'98	RADIATOR R/S NATURE (45287)'98	1
4	546.35.034.200	KÜHLERSCHUTZ LINKS FARBLOS '95	RADIATOR PROTECT. L/S WHITE'95	1
5	546.35.134.200	KÜHLERSCHUTZ RECHTS FARBLOS'95	RADIATOR PROTECT. R/S WHITE'95	1
9*	503.35.026.000	KÜHLERSCHLAUCH KPL. 125-380'98	RADIATOR HOSE CPL. 125-380'98	1
12	100.01.020.000	SCHLAUCHKLEMME GEMI 16/27	HOSE CLAMP GEMI 16/27	X
13*	547.35.027.000	FORMSCHLAUCH 18X25 250-380'98 WASSERPUMPE - KÜHLER	RADIATOR HOSE 18X25 250-380'98 WATER PUMP - RADIATOR	1
15	550.07.016.001	SCHLAUCH 7X10 PER METER	PVC-HOSE 7X10 PER METER	0,2
16	440.11.076.200	KABELBAND 200MM	CABLE TIE 200MM	X
18	503.03.089.000	WINKELSTÜCK '97	ANGEL PIECE '97	1
19*	547.35.025.000	FORMSCHLAUCH 18X25 125-380'98 KÜHLER - KÜHLER	RADIATOR HOSE 18X25 250-380'98 RADIATOR - RADIATOR	1
20	410.01.052.000	KABELTÜLLE D=12MM	RUBBER SLEEVE D=12MM	4
21	510.06.097.000	SCHEIBE 6,4X22X1	WASHER 6,4X22X1	4
22	0015 060123	SK.BUNDSCHRAUBE M 6X12 SW=8	HH COLLAR SCREW M 6X12 WS=8	4
30*	546.35.013.144	THERMOSTATGEH. KPL. 55GRAD '98	THERMOSTATCASE CPL. 55DEG. '98	1
31	0770 320020	O-RING 32,00X2,00	O-RING 32,00X2,00	2
32	546.35.017.000	THERMOSTAT 55 GRAD '94	THERMOSTAT 55 DEGREES '94	1

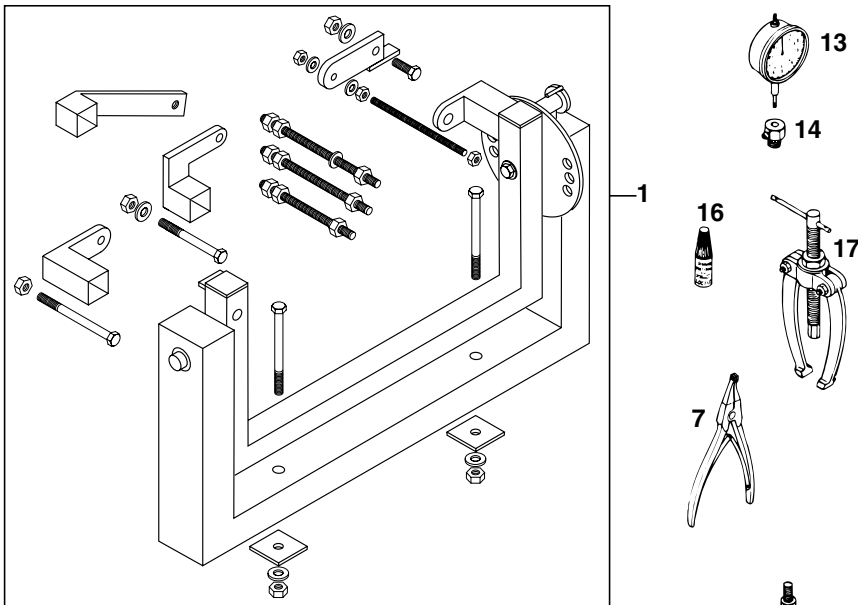
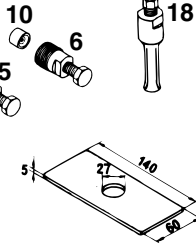
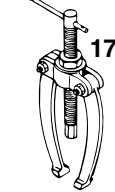
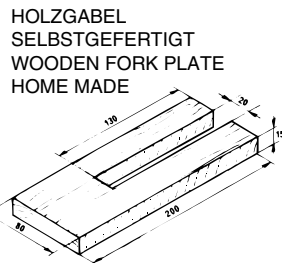

FIG	TEILNR/PARTNR	BEZEICHNUNG	DESCRIPTION	QTY
1	560.12.001.000	UNIVERSALMONTAGEBOCK '96	UNIVERSAL MOUNTING RACK '96	1
3	546.29.003.000	KUPPLUNGSHALTER 250'90	CLUTCH HOLDER 250 '90	1
4	560.12.004.000	ZAHNRADSEGMENT	GEAR WHEEL SEGMENT	1
5	546.29.009.044	MAGNETABZIEHER M27X1 KOKUSAN	MAGNETIC PULLER M27X1 KOKUSAN	1
6	6 276 807	MAGNETABZIEHER M26X1,5 SEM/MOT	PULLER M26X1,5 SEM/MOT	1
7	510.12.011.000	SEEGERRINGZANGE VERKEHRT	SPECIAL CIRCLIP PLIER	1
8	544.12.012.000	HALTESCHLÜSSEL FÜR ROTOR SEM	HOLDING SPANNER FOR FLYWHEEL	1
9	510.12.014.000	GRADSCHIEBE	TIMING DEGREE DISC	1
10	510.12.016.000	SCHUTZKAPPE F. KURBELWELLE M12	PROTECTION CAP CRANKSHAFT M12	1
11	546.29.012.000	HALTESCHLÜSSEL ROTOR 2K-1/2K-2	HOLD. SPANNER ROTOR 2K-1/2K-2	1
13	501.12.013.000	MESSUHR 0-10 MM	DIAL GAUGE 0-10MM	1
14	501.12.030.000	MESSUHRHALTER	DIAL GAUGE SUPPORT	1
16	6 899 785	LOCTITE 242 BLAU 6CCM	LOCTITE 242 BLUE 6CCM	1
17	151.12.017.000	LAGERAUSZIEHER	BEARING EXTRACTOR	1
18	151.12.018.100	EINSATZ 18-23 MM	INTERN.BEAR.PULLER 18-23 MM	1
18	151.12.018.000	EINSATZ 12-16 MM	INTERN.BEAR.PULLER 12-16 MM	1
18	151.12.018.200	EINSATZ 5-7 MM	INTERN.BEAR.PULLER 5-7 MM	1
19	546.29.027.000	NIETWERKZEUG FÜR KUPPLUNG	RIVETTING TOOL FOR CLUTCH	1
25	0276 179 000	ABZIEHER FÜR PRIMÄRRAD	EXTRACTOR PR.GEAR	1



STAHLPLATTE
SELBSTGEFERTIGT
STEEL PLATE
HOME MADE



HOLZGABEL
SELBSTGEFERTIGT
WOODEN FORK PLATE
HOME MADE

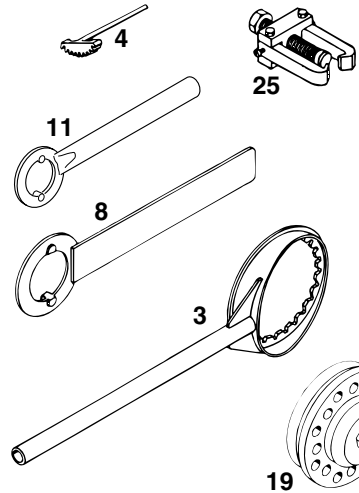

TECHNISCHE DATEN – MOTOR 250/300/380 SX/EXC/EGS '98

Motor	250 SX	250 EXC, EGS	300 EXC, EGS	380 SX	380 EXC, EGS
Bauart	Flüssigkeitsgekühlter Einzylinder-Zweitakt-Ottomotor mit KTM Twin Valve Control Auslaßsteuersystem und KTM Torque Chamber				
Hubraum	249 cm ³		297 cm ³	368 cm ³	
Bohrung / Hub	67,5 / 69,5 mm		72 / 73 mm	78 / 77 mm	
Kraftstoff	Superkraftstoff ROZ 95 bleifrei, mit hochwertigem Zweitaktöl gemischt (Shell Advance Racing X)				
Mischungsverhältnis	1:50–1:60 bei Verwendung von hochwertigen Zweitaktölen. Im Zweifelsfall setzen Sie sich bitte mit Ihrem Importeur in Verbindung oder mischen Sie vorsichtshalber 1:40				
Kurbelwellenlagerung	1 Rillenkugellager / 1 Zylinderrollenlager				
Pleuellager	Nadellager				
Kolbenbolzenlager	Nadellager				
Kolben	Gußkolben		Schmiedekolben	Gußkolben	
Kolbenring	2 Rechteckringe				
Maß "X" <small>(Kolbenoberkante-Zylinderoberkante)</small>	0 + 0,1 mm				
Zündzeitpunkt	1,9 mm (17 Grad) vor OT	1,2 mm (13,5 Grad) vor OT	1,2 mm (13,5 Grad) vor OT	2,1 mm (17 Grad) vor OT	1,4 mm (14,5 Grad) vor OT
Zündkerze	NGK BR 8 ECM				
Elektrodenabstand	0,60 mm				
Maß "Z" <small>(Höhe der Steuerklappe)</small>	48 mm		46 mm	50,5 mm	
TVC Verstellbeginn	5400/min		5300/min	5200/min	
TVC Verstellende	7550/min		7750/min	7200/min	
Primärtrieb	Gerade verzahnte Stirnräder, Primärübersetzung 25:72			Gerade verzahnte Stirnräder, Primärübersetzung 26:72	
Kupplung	Mehrscheibenkupplung im Ölbad				
Getriebe	Klauengeschaltetes 5-Gang-Getriebe				
Getriebeübersetzung					
1. Gang	15:29		15:29	15:29	15:29
2. Gang	17:27		18:26	18:26	18:26
3. Gang	19:25		19:22	19:24	19:22
4. Gang	21:23		21:20	21:23	21:20
5. Gang	23:21		23:18	23:21	23:18
Getriebeschmierung	0,8 l Motoröl 20W-40 (Shell Advance VSX4)				
Übersetzung Hinterrad	14:50	14:50 / 15:48 / 15:40 / 13:50	4:50 / 15:48 / 15:40	14:50	13:50 / 15:40
Lieferbare Kettenritzel	13Z / 14Z / 15Z für Kette ⁵ / ₈ x ¹ / ₄ "				
Lieferbare Kettenräder	38Z / 40Z / 42Z / 45Z / 48Z / 50Z / 52Z für Kette ⁵ / ₈ x ¹ / ₄ "				
Kühlflüssigkeit	1,3 Liter, Mischungsverhältnis 40% Frostschutz, 60% Wasser, mindestens -25° C				
Zündanlage	KOKUSAN 2K-1	SEM K11		KOKUSAN 2K-1	SEM K11
Generatorleistung	kein Generator	12V 130W		kein Generator	12V 130W
Vergaser	Flachschieber-Vergaser, Einstellung siehe Tabelle 3				
Luftfilter	Schaumstoff-Naßluftfilter-Einsatz				

TOLERANZEN-EINBAUSPIELE	
Kolbeneinbauspiel	0,05 mm (250) 0,06 mm (300) 0,08 mm (380)
Kolbenring – Stoßspiel	0,3–0,4 mm
Pleuellager – Radialspiel	0,021–0,032 mm
Getriebewellen – Axialspiel	0,1–0,2 mm
Kupplungsdruckfedern – Länge	Ø 2,5 neu = 43 mm, Mindestlänge = 42 mm

DICHTUNGSSTÄRKEN	
Motorgehäuse	0,5 mm
Kupplungsdeckel	0,5 mm
Zylinderfußdichtung	nach Bedarf
Lieferbare Fußdichtungen	0,2/0,4/0,5/0,7 mm
Zylinderkopfdichtung	O-Ringe

ANZUGSDREHMOMENTE		
Bundschrauben-Zylinderkopf	M 8	35 Nm
Bundmuttern-Zylinderfuß	M 10	35 Nm
Bundmutter-Schwungrad	M 12x1	60 Nm
Mutter für Primärrad (Linksgewinde)	M 18x1,5	150 Nm
Mutter für Kupplungsmitnehmer	M 18x1,5	100 Nm
Motorgehäuse und Deckelschrauben	M 6	8 Nm
Schwingarmbolzen	M 14	100 Nm
Bundmutter Steckachse hinten	M 20x1,5	80 Nm
Restliche Schrauben	M 6	10 Nm
	M 8	30 Nm
	M 10	50 Nm

VERGASER-GRUNDEINSTELLUNG						
TABELLE 3		250 EGS AUSTRALIEN	250 SX EUROPA 250 EXC EUROPA 250 EGS FRANKREICH	300 EXC EUROPA 300 EGS AUSTRALIEN 300 EGS FRANKREICH	380 EGS AUSTRALIEN	380 SX, EXC EUROPA
		Vergasertyp	Keihin PWK 38	Keihin PWK 38	Keihin PWK 38	Keihin PWK 38
	Regulierungsnummer	240496	280495	210495	300596	200596
	Hauptdüse	175 (170/180)	175 (170)	175 (170)	175 (170/165)	175 (165/170)
	Leerlaufdüse	45 (42/48)	45 (42)	45 (42/48)	45 (42/40)	45 (42/48)
	Startdüse	85	85	85	85	85
	Düsennadel	N85C (N85D)	N85D (N85E)	N85C	NOZG (NOZH/NOZI)	NOZH (NOZI)
	Nadelposition von oben	III	III	III	II	II
	Schieber	6	6	6	6	6
	Luftregulierschr. offen	1,5 Umdr.	1,5 Umdr.	1,5 Umdr.	1,5 Umdr.	1,5 Umdr.

TECHNICAL DATA - ENGINE 250/300/380 SX/MXC/EXC '98 (only USA)

Engine	250 SX	250 EXC, MXC	300 EXC, MXC	380 SX	380 EXC, MXC		
Design	Liquid-cooled single-cylinder two-stroke engine with KTM Twin Valve Control exhaust system and KTM Torque Chamber						
Piston displacement	249 ccm		297 ccm		368 ccm		
Bore / stroke	67.5 / 69.5 mm (2.66 / 2.74 in)		72 / 73 mm (2.84 / 2.88 in)		78 / 77 mm (3 / 2.98 in)		
Fuel	SUPER fuel, research octane no 95, mixed with high-grade two stroke oil (Shell Advance Racing X)						
Oil / gasolin ratio	1:50 - 1:60 when using high grade two stroke oil. When in dought, please contact your importer or use 1:40 mix ratio to be on the safe side						
Crankshaft bearing	1 deep-groove ball bearing / 1 cylinder roller bearing						
Connecting rod bearing	needle bearing						
Piston pin bearing	needle bearing						
Piston	cast piston		forged piston		cast piston		
Piston ring	two plain compression rings						
Dimension "X" <small>(upper edge piston - upper edge cylinder)</small>	0 +0.1 mm (0 + 0.004 in)						
Ignition timing	1.8 mm (0.07 in) (17 °) BTDC		2.0 mm (0.08 in) (17°) BTDC		2.2 mm (0.09 in) (17 °) BTDC		
Spark plug	NGK BR 8 ECM						
Electrode gap	0.6 mm (0.024 in)						
Dimension "Z" <small>(height of the control flap)</small>	48 mm (1.9 in)		46 mm (1.7 in)		50.5 mm (1.99 in)		
TVC start open	5400/min		5300/min		5200/min		
TVC fully open	7550/min		7750/min		7200/min		
Primary drive	straight cut spur gears, primary ratio 25:72			straight cut spur gears, primary ratio 26:72			
Clutch	multiple disc clutch in oil bath						
Transmission	5 speed, claw actuated						
Gear ratio			EXC	M-XC		EXC	MXC
1 st Gear	15:29	15:29	15:29	15:29	15:29	15:29	15:29
2 nd Gear	17:27	18:26	18:26	18:26	18:26	18:26	18:26
3 rd Gear	19:25	19:22	19:22	19:24	19:24	19:22	19:24
4 th Gear	21:23	21:20	21:20	21:23	21:23	21:20	21:23
5 th Gear	23:21	23:18	23:18	23:21	23:21	23:18	23:21
Gear lubrication	0.8 l engine oil 20W-40 (Shell Advance VSX4)						
Rear wheel ratio	14:50	14:52			14:50	14:52	
Available chain sprockets	13t / 14t / 15t for chain 5/8 x 1/4"						
Available final sprockets	38t / 40t / 42t / 45t / 48t / 50t / 52t for chain 5/8 x 1/4"						
Coolant	1.3 litres, 40% anti freeze, 60% water, at least -25 °C (-13 °F)						
Ignition system	KOKUSAN 2K-1	KOKUSAN 2K-2			KOKUSAN 2K-1	KOKUSAN 2K-2	
Generator output	no generator	12V 40W			no generator	12V 40W	
Carburetor	flat-slide carburetor, carburetor setting see table 3						
Air-filter	wet foam type air filter insert						

TOLERANCES AND FITTING CLEARANCES			
Piston fitting clearance	0.05 mm (250)	0.06 mm (300)	0.08 mm (380)
Piston ring end gap	0.3–0.4 mm		
Connecting rod bearing - radial clearance	0.021–0.032 mm		
Transmission shafts end float	0.1–0.2 mm		
Clutch springs - length	Ø 2.5 new = 43 mm, minimum length = 42 mm		

GASKET THICKNESSES	
Crankcase	0.5 mm
Clutch cover	0.5 mm
Cylinder bottom gasket	as required
Available cylinder bottom gaskets	0.2/0.4/0.5/0.7 mm
Cylinder-head gasket	O-rings

BASIC CARBURETOR SETTING			
TABLE 3		250 SX/MXC/EXC USA 300 MXC/EXC USA	380 SX/MXC/EXC USA
	Carburetor	Keihin PWK 38	Keihin PWK 38
	Carburetor setting number	240496	200597
	Main jet	175 (170/180)	175 (165/170/180)
	Idling jet	45 (42/48)	45 (42/48)
	Starting jet	85	85
	Jetneedle	N85C (N85D)	NOZG (NOZH)
	Needle position from top	III	III
	Throttle valve	6	6
	Air adjustment screw open	1,5 turn	1,5 turn

TIGHTENING TORQUES			
Flange bolts - cylinder-head	M 8	35 Nm	(25 ft.lb)
Nuts-cylinder base	M 10	35 Nm	(25 ft.lb)
Flywheel collar nut	M 12x1	60 Nm	(44 ft.lb)
Nut for primary sprocket (LH thread)	M 18x1.5	150 Nm	(110 ft.lb)
Nut for inner clutch hub	M 18x1.5	100 Nm	(74 ft.lb)
Crankcase and cover bolts	M 6	8 Nm	(6 ft.lb)
Swingarm pivot	M 14	100 Nm	(74 ft.lb)
Collar nut rear wheel spindle	M 20x1.5	80 Nm	(60 ft.lb)
Other screws	M 6	10 Nm	(7 ft.lb)
	M 8	30 Nm	(22 ft.lb)
	M 10	50 Nm	(37 ft.lb)

TECHNICAL DATA - ENGINE 250/300/380 SX/MAXC/EXC/EGS '98 (all models out of USA)

Engine	250 SX	250 EXC, EGS	300 EXC, EGS	380 SX	380 EXC, EGS
Design	Liquid-cooled single-cylinder two-stroke engine with Twin Valve Control exhaust system and KTM Torque Chamber				
Piston displacement	249 ccm		297 ccm	368 ccm	
Bore / stroke	67.5 / 69.5 mm (2.66 / 2.74 in)		72 / 73 mm (2.84 / 2.88 in)	78 / 77 mm (3 / 2.98 in)	
Fuel	SUPER fuel, research octane no 95, mixed with high-grade two stroke oil (Shell Advance Racing X)				
Oil / gasoline ratio	1:50 - 1.60 when using high grade two stroke oil. When in doubt, please contact your importer or use 1:40 mix ratio to be on the safe side				
Crankshaft bearing	1 deep-groove ball bearing / 1 cylinder roller bearing				
Connecting rod bearing	needle bearing				
Piston pin bearing	needle bearing				
Piston	cast piston		forged piston	cast piston	
Piston ring	two plain compression rings				
Dimension "X" <small>(upper edge piston - upper edge cylinder)</small>	0 + 0.1 mm (0 + 0.004 in)				
Ignition timing	1,9 mm (0.07 in) (17 °) BTDC	1.2 mm (0.05 in) (13.5 °) BTDC	1.2 mm (0.05 in) (13.5 °) BTDC	2.1 mm (0.08 in) (17 °) BTDC	1.4 mm (0.06 in) (13 °) BTDC
Spark plug	NGK BR 8 ECM				
Electrode gap	0.6 mm (0.024 in)				
Dimension "Z" <small>(height of the control flap)</small>	48 mm (1.9 in)		46 mm (1.7 in)	50.5 mm (1.99 in)	
TVC start open	5400/min		5300/min	5200/min	
TVC fully open	7550/min		7750/min	7200/min	
Primary drive	straight cut spur gears, primary ratio 25:72			straight cut spur gears, primary ratio 26:72	
Clutch	multiple disc clutch in oil bath				
Transmission	5 speed, claw actuated				
Gear ratio					
1 st Gear	15:29		15:29	15:29	15:29
2 nd Gear	17:27		18:26	18:26	18:26
3 rd Gear	19:25		19:22	19:24	19:22
4 th Gear	21:23		21:20	21:23	21:20
5 th Gear	23:21		23:18	23:21	23:18
Gear lubrication	0,8 l engine oil 20W-40 (Shell Advance VSX4)				
Rear wheel ratio	14:50	14:50 / 15:48 / 15:40 / 13:50	14:50 / 15:48 / 15:40	14:50	13:50 / 15:40
Available chain sprockets	13t / 14t / 15t for chain $\frac{5}{8} \times \frac{1}{4}$ "				
Available final sprockets	38t / 40t / 42t / 45t / 48t / 50t / 52t for chain $\frac{5}{8} \times \frac{1}{4}$ "				
Coolant	1.3 litres, 40% anti freeze, 60% water, at least -25 °C (-13 °F)				
Ignition system	KOKUSAN 2K-1	SEM K11		KOKUSAN 2K-1	SEM K11
Generator output	no generator	12V 130W		no generator	12V 130W
Carburetor	flat-slide carburetor, carburetor setting see table 3				
Air-filter	wet foam type air filter insert				

TOLERANCES AND FITTING CLEARANCES	
Piston fitting clearance	0.05 mm (250) 0.06 mm (300) 0.08 mm (360)
Piston ring end gap	0.3–0.4 mm
Connecting rod bearing - radial clearance	0.021–0.032 mm
Transmission shafts end float	0.1–0.2 mm
Clutch springs - length	∅ 2.5 mm new = 43 mm, minimum length = 42 mm

GASKET THICKNESSES	
Crankcase	0.5 mm
Clutch cover	0.5 mm
Cylinder bottom gasket	as required
Available cylinder bottom gaskets	0.2/0.4/0.5/0.7 mm
Cylinder-head gasket	O-rings

TIGHTENING TORQUES			
Flange bolts - cylinder-head	M 8	35 Nm	(25 ft.lb)
Nuts-cylinder base	M 10	35 Nm	(25 ft.lb)
Flywheel collar nut	M 12x1	60 Nm	(44 ft.lb)
Nut for primary sprocket (LH thread)	M 18x1.5	150 Nm	(110 ft.lb)
Nut for inner clutch hub	M 18x1.5	100 Nm	(74 ft.lb)
Crankcase and cover bolts	M 6	8 Nm	(6 ft.lb)
Swingarm pivot	M 14	100 Nm	(74 ft.lb)
Collar nut rear wheel spindle	M 20x1.5	80 Nm	(60 ft.lb)
Other screws	M 6	10 Nm	(7 ft.lb)
	M 8	30 Nm	(22 ft.lb)
	M 10	50 Nm	(37 ft.lb)

BASIC CARBURETOR SETTING						
TABLE 3		250 EGS AUSTRALIA	250 SX EUROPE 250 EXC EUROPE 250 EGS FRANCE	300 EXC EUROPE 300 EGS AUSTRALIA 300 EGS FRANCE	380 EGS AUSTRALIA	380 SX, EXC EUROPE
		Carburetor	Keihin PWK 38	Keihin PWK 38	Keihin PWK 38	Keihin PWK 38
	Carburetor setting number	240496	280495	210495	300596	200596
	Main jet	175 (170/180)	175 (170)	175 (170)	175 (170/165)	175 (165/170)
	Idling jet	45 (42/48)	45 (42)	45 (42/48)	45 (42/40)	45 (42/48)
	Starting jet	85	85	85	85	85
	Jetneedle	N85C (N85D)	N85D (N85E)	N85D	NOZG (NOZH/NOZI)	NOZH (NOZI)
	Needle position from top	III	III	III	II	II
	Throttle valve	6	6	6	6	6
	Air adjustment screw open	1.5 turn	1.5 turn	1.5 turn	1.5 turn	1.5 turn

K T M - S P O R T M O T O R C Y C L E A G
A-5230 Mattighofen • Postfach 91 • Austria
Internet: <http://www.ktm.co.at>
FN 102019 d - Landesgericht Ried im Innkreis

Gedruckt auf chlorfrei gebleichtem, umweltfreundlichen Papier. - dunmayer-druck-mattighofen

