

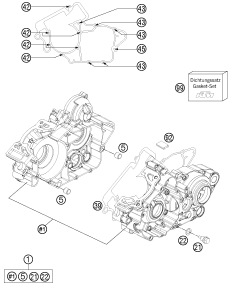

200 EXC / 200 XC-W 2015

ART.-NR.: 3CM0820350EN

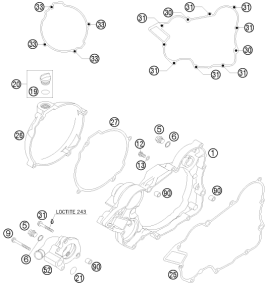
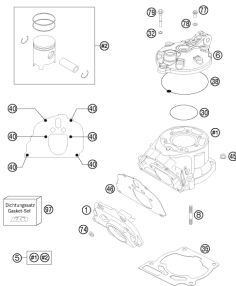
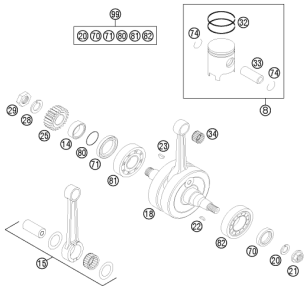
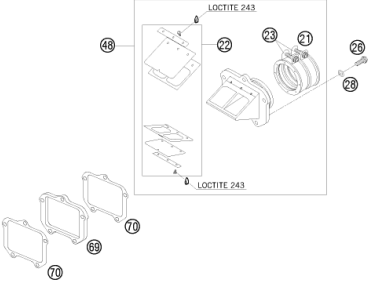
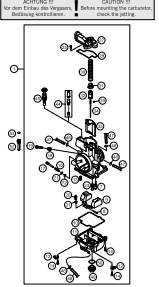
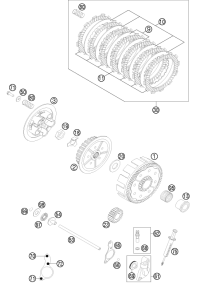
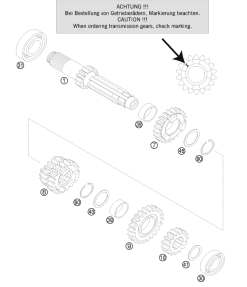
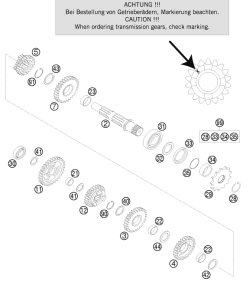
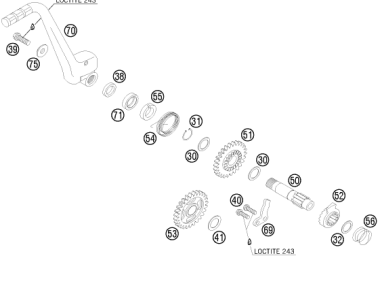
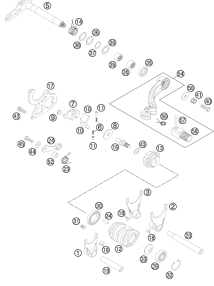
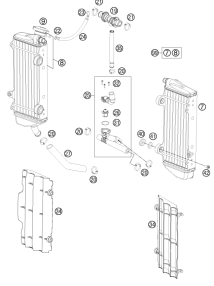
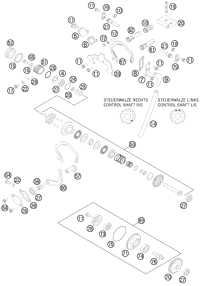
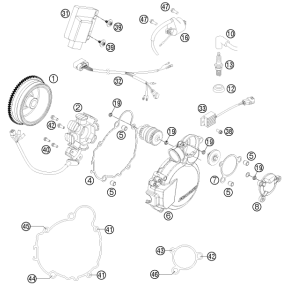
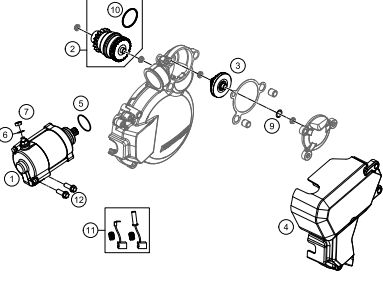

<p>ENGINE CASE</p>  <p style="text-align: right;">3</p>	<p>CLUTCH COVER</p>  <p style="text-align: right;">4</p>	<p>CYLINDER, CYLINDER HEAD</p>  <p style="text-align: right;">5</p>	<p>CRANKSHAFT, PISTON</p>  <p style="text-align: right;">6</p>
<p>REED VALVE CASE</p>  <p style="text-align: right;">7</p>	<p>CARBURETOR</p>  <p style="text-align: right;">8</p>	<p>CLUTCH</p>  <p style="text-align: right;">10</p>	<p>TRANSMISSION I - MAIN SHAFT</p>  <p style="text-align: right;">11</p>
<p>TRANSMISSION II - COUNTERSHAFT</p>  <p style="text-align: right;">12</p>	<p>KICK STARTER</p>  <p style="text-align: right;">13</p>	<p>SHIFTING MECHANISM</p>  <p style="text-align: right;">14</p>	<p>COOLING SYSTEM</p>  <p style="text-align: right;">16</p>

<p>EXHAUST CONTROL</p>  <p style="text-align: right;">17</p>	<p>IGNITION SYSTEM</p>  <p style="text-align: right;">19</p>	<p>ELECTRO STARTER</p>  <p style="text-align: right;">20</p>	
	<div style="display: flex; align-items: center;">  <p> All information contained is without obligation. KTM Sportmotorcycle GmbH particularly reserves the right to modify any equipment, technical specifications, prices, colors, shapes, materials, services, service work, constructions, equipment and the like so as to adapt them to local conditions or to cancel any of the above items, all without previous announcement and without giving reasons. KTM may stop manufacturing certain models without previous notice. KTM shall not be held liable for any deviations of availability and/or ability to deliver, illustrations, descriptions, printing and/or other errors. The illustrated models partly contain extra equipment, which is not applied to standard models. © by KTM Sportmotorcycle GmbH, Mattighofen AUSTRIA; All rights reserved; Reprint, also in extracts, with written allowance of KTM Sportmotorcycle GmbH, Mattighofen only. </p> </div>		

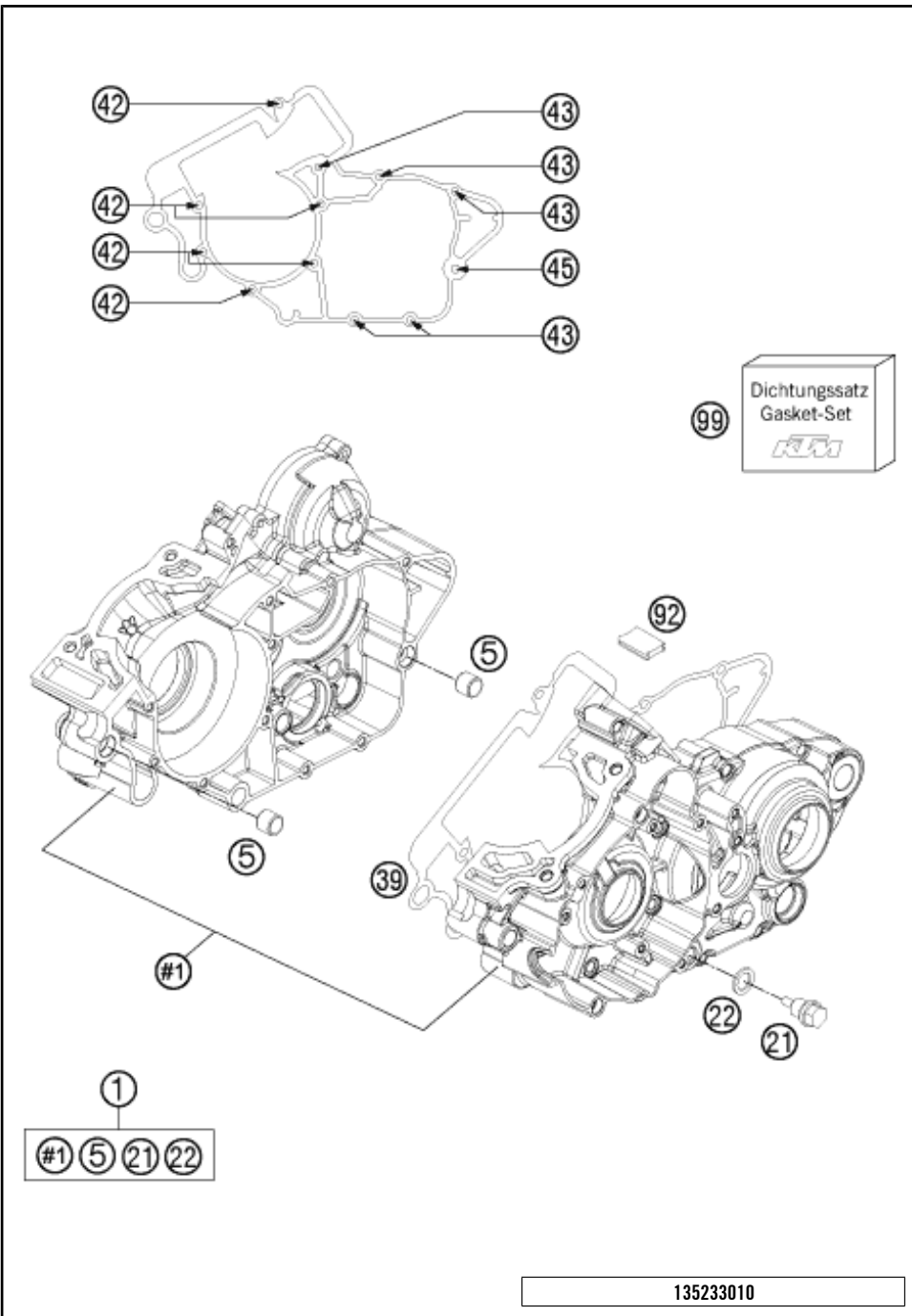

POS	PARTNUMBER	PARTNAME	PIECE
1	5243000033	ENGINE CASE KPL. 125-200 13	1
5	54630027000	DOWEL BUSHING 13,8X11X12	2
21	58030021000	OILDRAIN PLUG W.MAG. M 12X1,5	1
22	58038022000	CU-SEAL RING DIN7603-12X18X1,5	1
39	50330039000	ENGINE CASE GASKET 0,5MM '98	1
42	0025060506	HH COLLAR SCREW M6X50 TX30	6
43	0025060556	HH COLLAR SCREW M6X55 TX30	5
45	0025060606	HH COLLAR SCREW M6X60 TX30	1
92	50330092000	OIL GUARD GROMMET 25X31 '98	1
99*	50330099201	GASKET SET	1

135233010

C145243010

* NEW PART X ON DEMAND

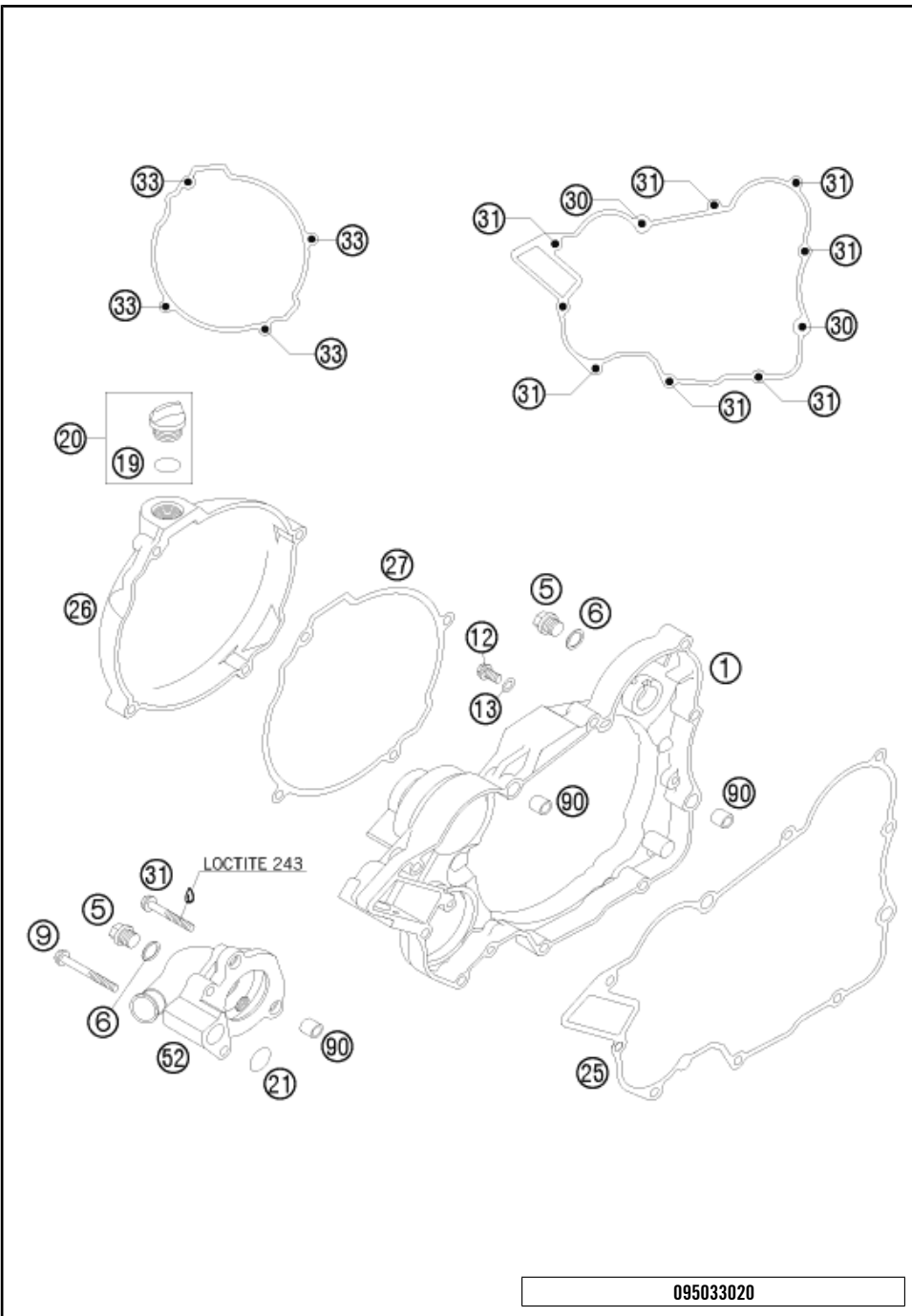

POS	PARTNUMBER	PARTNAME	PIECE
1	5033000114415	CLUTCH COVER CPL. 125/200 09	1
5	0910100003	PLUG DIN0910-M 10X1	2
6	0603100141	COPPER GASKET DIN7603-10X14X1	2
9	0025060506	HH COLLAR SCREW M6X50 TX30	2
12	0025060126	HH COLLAR SCREW M6X12 TX30	1
13	0603061001	CU-SEAL RING DIN7603-6X10X1	1
19	0770191015	O-RING 19,00X3,00 NBR	1
20	58030120000	OIL FILLER CAP M24x3 WITH O-R	1
21	0770160030	O-RING 16,00X3,00 NBR 70	1
25	50330025000	CLUTCH COVER GASKET 0,5MM	1
26	5033002610015	CLUTCH OUTSIDE COVER	1
27	50330027000	CLUTCH OUTS.COVER GASKET 1MM	1
30	0025060406	HH COLLAR SCREW M6X40 TX30	2
31	0025060356	HH COLLAR SCREW M6X35 TX30	9
33	0025060306	HH COLLAR SCREW M6X30 TX30	4
52	50335052000	% WATER PUMP COVER 125/200 98	1
90	49030090000	DOWEL 9,8 X 7 X 10	4

095033020

C105033020

* NEW PART X ON DEMAND

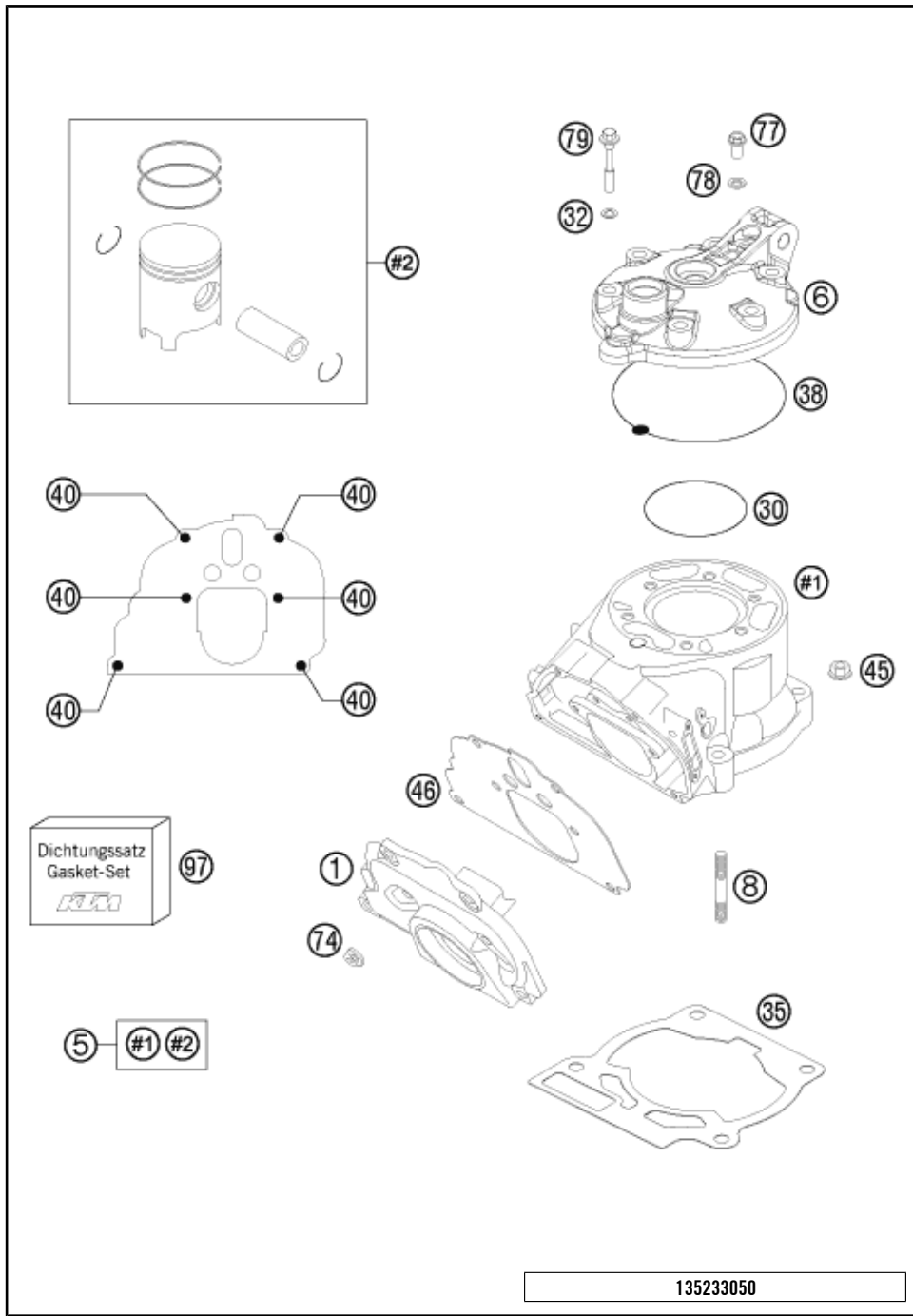

POS	PARTNUMBER	PARTNAME	PIECE
1	52337001200	INTERMEDIATE FLANGE 200 2000	1
5	52330038300	CYLINDER + PISTON CPL.	1
6	52330006300	CYLINDER HEAD EXC 200 MOD. 13	1
8	0835080355	STUD DIN0835-M 8X35 10.9	4
30	0770720021	O-RING 72,00X2,00 VITON	1
32	0603070121	CU-SEAL RING DIN7603- 7,3X12X1	6
35	50330035020	CYLINDER BASE GASKET 0,20MM	x
35	50330035025	CYLINDER BASE GASKET 0,25MM	x
35	50330035040	CYLINDER BASE GASKET 0,40MM	x
35	50330035050	CYLINDER BASE GASKET 0,50MM	x
35	50330035075	CYLINDER BASE GASKET 0,75MM	x
38	52330137000	CYL.HEAD SEAL RING 200 2003	1
40	0014050203	HH COLLAR SCREW M 5X20 WS=6	6
45	50330045000	HH COLLAR NUT M 8 WS=12	4
46	52337046100	INTERMED.GASKET 1,1MM 200 2000	1
74	51005074000	RETAINING PLATE	2
77	0025060106	HH COLLAR SCREW M6X10 TX30	1
78	0603061001	CU-SEAL RING DIN7603-6X10X1	1
79	50030079000	CYL. HEAD BOLT M 7X40 WS=10	6
97	50330097000	GASKET SET CYL. 125/200 98-11	1

* NEW PART X ON DEMAND

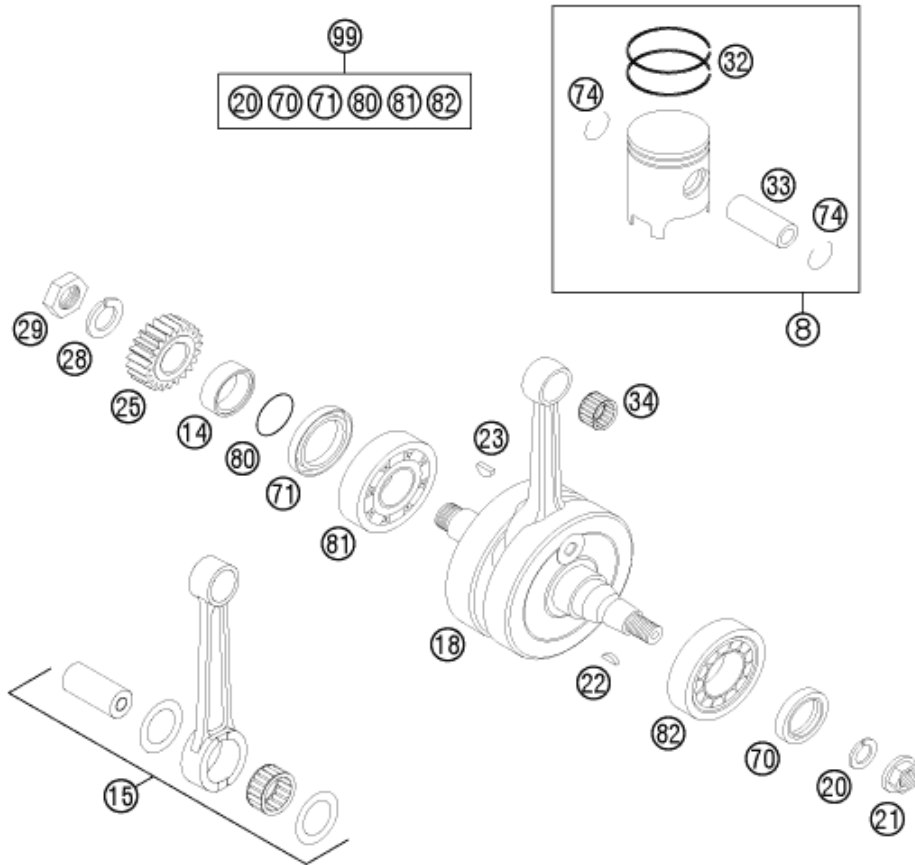

POS	PARTNUMBER	PARTNAME	PIECE
8	52330007300 I	PISTON I CPL. 64MM 200 2004	1
8	52330007300 II	PISTON II CPL. 64MM 200 2004	1
14	54633014100	SPACER BUSHING 12MM	1
15	52330015100	CON.ROD REPAIR KIT 200'07	1
18	52330018200	CRANKSHAFT CPL. 200 EXC 2007	1
20	50230029012	LOCKING RING VSK 12	1
21	49030021000	COLLAR NUT M12X1 R/S	1
22	0888030050	WOODRUFF KEY DIN6888-3X5X13	1
23	6946005	WOODRUFF KEY 5X6,5 HARDED	1
25	50332023123	PRIMARY PINION 23-T 125/200 06	1
28	50230029016	LOCKING RING VSK 16	1
29	50330029000	HEXAGON NUT M 16 X 1,5 - L/S	1
32	52330032100	SQUARE RING 64X1 200 2002	x
33	52330033100	PISTON PIN 11X16X46 200 02	1
34	52330034000	NEEDLE BEARING KV16X20X20 FN	1
70	0760253570	SHAFT SEAL RING 25X35X7 BTSL	1
71	0760324564	SHAFT SEAL RING 32X45X6,5 BT	1
74	52330074100	WIRE LOCK RING 16X1,2	2
80	0770250020	O-RING 25,00X2,00 NBR 70	1
81	0625063055	BALL BEARING 6305 JR2 CS36	1
82	50330082000	CYL.ROLLER BEAR.NJ206 ET2XCS46	1
99	00050002300	CRANKSHAFT REP. KIT 125-200	x

115033060

C115233060

* NEW PART

X ON DEMAND

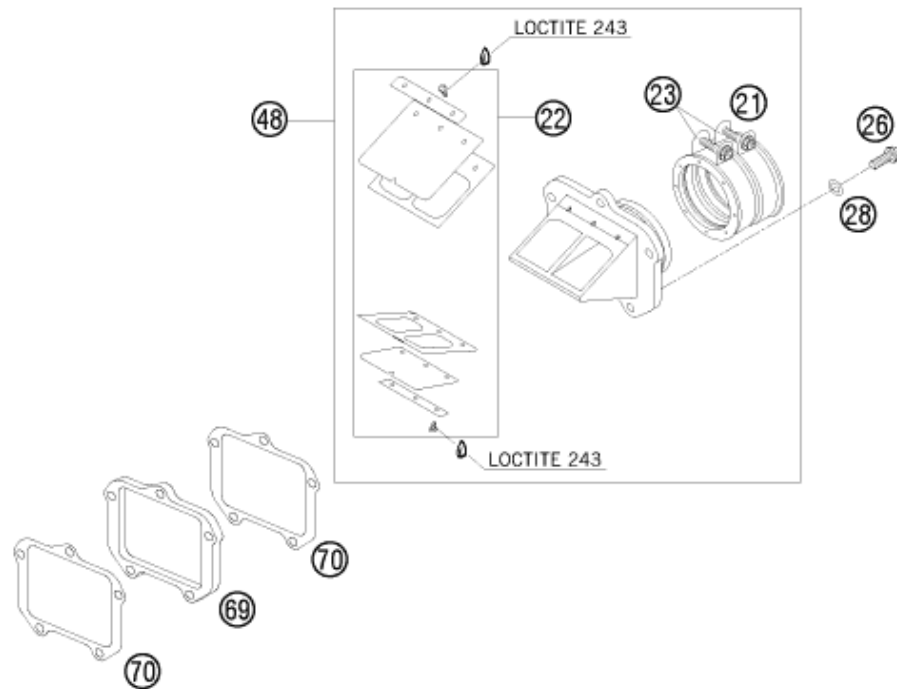

POS	PARTNUMBER	PARTNAME	PIECE
21	54736044000	RUBBER BOOT CPL. BOYESEN 2002	1
22	54730052000	REED VALVE CPL. BOYESEN 02	1
23	54830061000	CLAMP 54/09 MIXED	2
26	0025060256	HH COLLAR SCREW M6X25 TX30	5
28	0137060003	SPRING WASHER DIN0137-B 6	5
48	54730051044	REED VALVE ASSY CPL. 2000	1
69	54630098000	REED VALVE PLATE 6MM	1
70	50330098050	GASKET REED V.PLATE V-FORCE 04	2

085233070

C095233070

* NEW PART

X ON DEMAND

ACHTUNG !!! **CAUTION !!!**
 Vor dem Einbau des Vergasers, **!** Before mounting the carburetor,
 Bedüsung kontrollieren. **■** check the jetting.

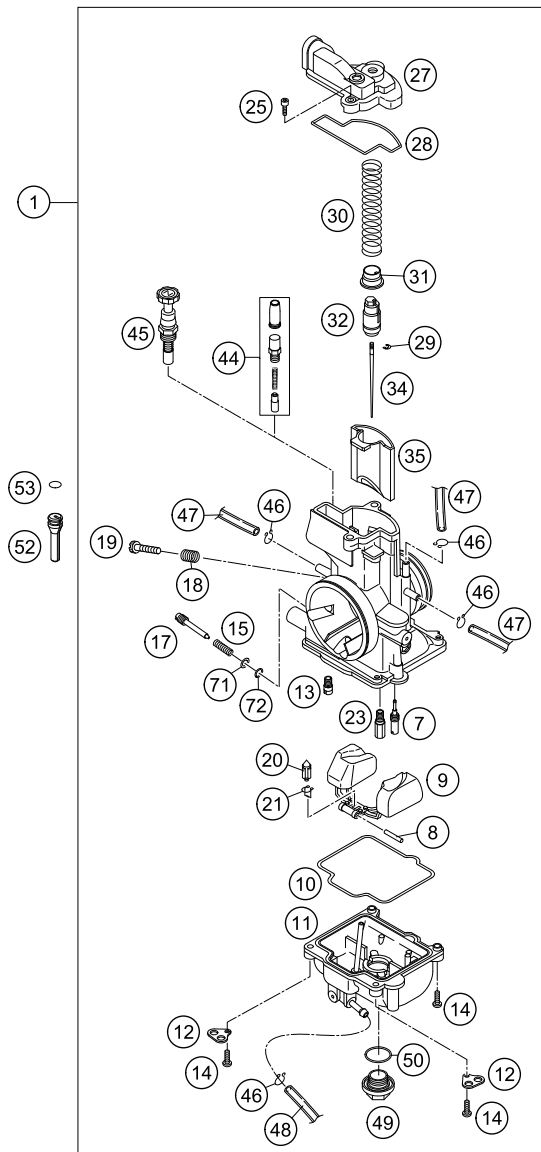

145243110

POS	PARTNUMBER	PARTNAME	PIECE
23	54531623175	MAIN JET 175 KEIHIN	x
25	54831025000	SPECIAL-AH-SCREW M 4X12	2
27	54831127000	CARBURETOR COVER PWK36-S AG	1
28	54831028000	GASKET FOR CARBURETOR COVER	1
29	54531629000	CLIP FOR JET NEEDLE	1
30	54831030000	SLIDING SPRING	1
31	54631231000	SPRING CAP	1
32	54631232000	NIPPLE	1
34	54531636030	JET NEEDLE NPRH KEIHIN	x
34	54831135000	JET NEEDLE KEIHIN N1EE 06	x
34	54831135100	JET NEEDLE KEIHIN N1EF 06	x
34	54831135200	JET NEEDLE KEIHIN N1EG 06	x
34	54831135300	JET NEEDLE KEIHIN N1EH 06	x
34	54831135500	JET NEEDLE KEIHIN N1EI 07	x
34	54831135600	JET NEEDLE KEIHIN N1EJ 07	x
34	54831135700	JET NEEDLE KEIHIN N1EK 07	x
35	54631035000	THROTTLE VALVE 7 FOR 38 PJ '00	1
44	58502096044	CONNECT. COLD START CABLE CPL. ONLY FOR EU	1
45	54631245000	STARTER PISTON CPL.	x
46	54531696000	CLAMP 6 MM	5
47	31007007101	PVC-HOSE 4X6MM	2
48	52031137001	PVC-HOSE 3X5MM	0
49	54531699000	PLUG M 18X1	1
50	0770180230	O-RING 18,00X2,30 NBR 70	1
52	52331029100	SLIDE STOP L=33 11 FOR EU	x
52	52331029000	SLIDE STOP L=36 08 FOR AUS	x
53	0770060018	O-RING 6,00X1,78	x
71	54831071000	WASHER ADJUSTING SCREW	1
72	54831072000	O-RING ADJUSTING SCREW	1

C155243110

* NEW PART X ON DEMAND

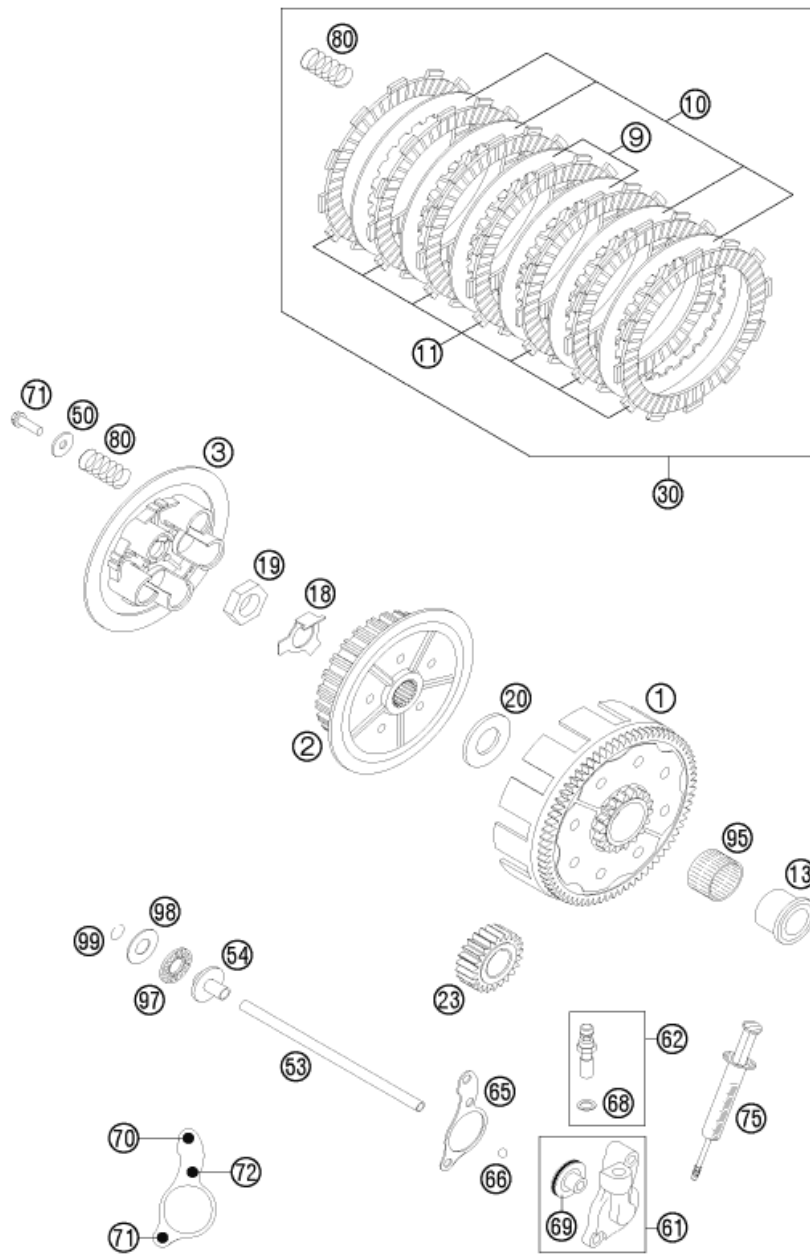

135233210

POS	PARTNUMBER	PARTNAME	PIECE
1	50332001044	OUTER CLUTCH HUB '98 WITHOUT PRIMARY PINION	1
2	50332002000	INNER CLUTCH HUB 125/200'98	1
3	50332003000	PRESSURE PLATE 125/200'98	1
9	50332010100	INTERMEDI. DISC STEEL 1,5MM'98	2
10	50332010400	INTERMEDIATE DISC 1,5MM	4
11	77032011000	LINING DISC 3,0MM 05	7
13	50332013000	INNER RING 20X26X25,9 '98	1
18	50332018000	SHEET METAL LOCK 1,5MM '98	1
19	0936181505	HEXAGON NUT DIN0936-M18X1,5 R.	1
20	50332020000	STOP DISK 20X39,6X3 '98	1
23	50332023023	PRIM. PINION 23-T 125/200'98	1
30	50332011210	CLUTCH KIT 125/200 06-14	1
50	50232050000	WASHER 6,2X18X2	5
53	50332017300	PUSH ROD L=178 125/200 2006	1
54	50332054051	% PRESSURE PIECE 125-380 '98	1
61	50332061044	CYLINDER CPL. 125/200'98	1
62	50332062000	HOLLOW SCREW CPL. M 10X1 '98	1
65	50332065051	CLUTCH RELEASE GASKET 0,3MM	x
65	50332065052	CLUTCH RELEASE GASKET 0,5MM	x
65	50332065053	CLUTCH RELEASE GASKET 0,75MM	x
66	0401070003	BALL DIN5401-7	1
68	42013226000	CU-SEAL RING DIN7603-10X16X1	1
69	50332066000	PISTON W. O-RING 125/200 2000	1
70	0025060406	HH COLLAR SCREW M6X40 TX30	1
71	0025060206	HH COLLAR SCREW M6X20 TX30	6
72	0025060256	HH COLLAR SCREW M6X25 TX30	1
75	50329050000	VENT INJEKTION HYDR. CLUTCH	1
80	52332005000	CLUTCH SPRING 2,4X40 200'98	5
95	56532095000	NEEDLE BEARING K26X30X22ZW.KSE	1
97	54637097200	AXIAL NEEDLE BEARING AXK 1226	1
98	54637098200	AXIAL WASHER AS1226 12X26X1	1
98	54637098300	AXIAL WASHER 12,5X25,8X1,5	x
99	0993012000	CIRCLIP DIN7993-RW12	1

C135233210

* NEW PART X ON DEMAND

ACHTUNG !!!
 Bei Bestellung von Getrieberädern, Markierung beachten.
CAUTION !!!
 When ordering transmission gears, check marking.

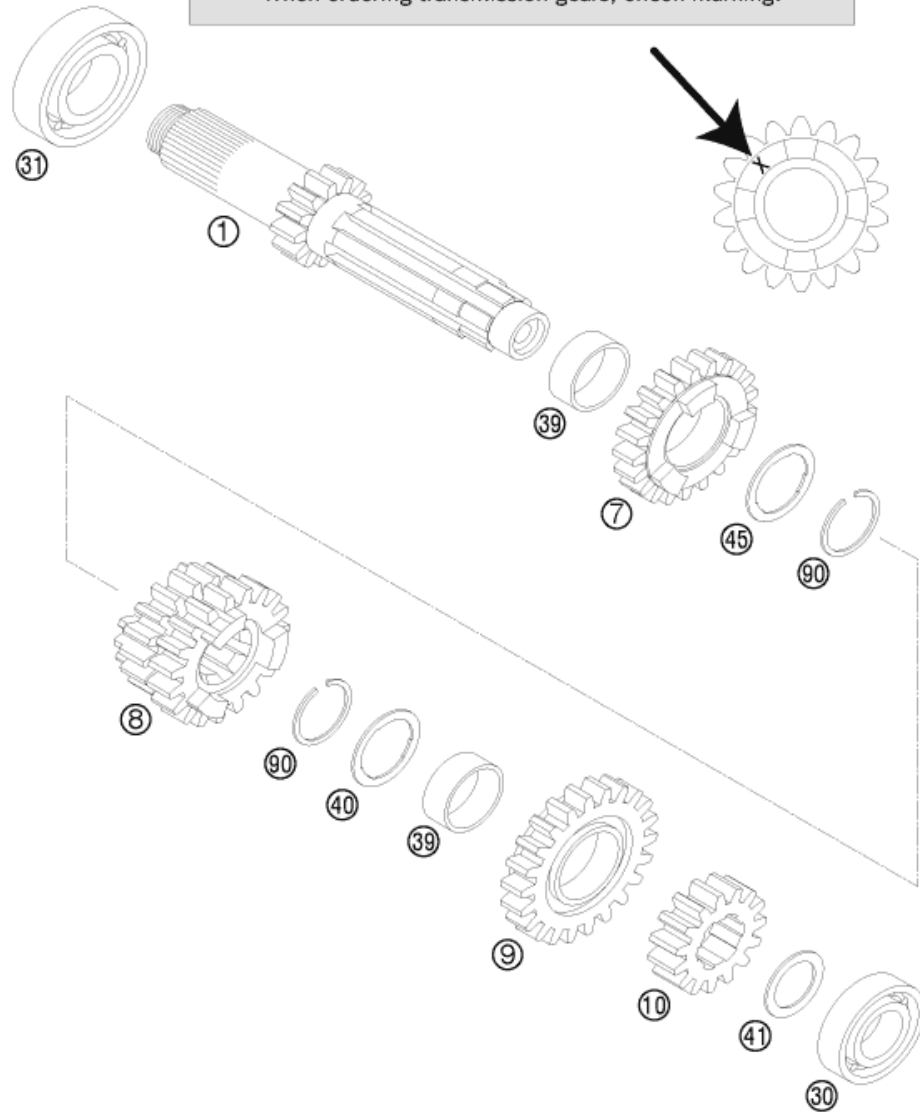

POS	PARTNUMBER	PARTNAME	PIECE
1	50333001144	MAIN SHAFT CPL. 12-T '98	1
7	52333007100	IDLER G. 5TH G.17-T "5G17H" 04	1
8	50333008100	SLIDING GEAR 3/4.G. 17/19-T 04 "3S17H"- "4S19H"	1
9	50333009400	IDLER G.6TH G. 22-T "6G22H" 04	1
10	50333010100	SOLID GEAR 2ND G.15-T"2S15" 03	1
30	0625160031	GROOVED BALL B. 16003 C4 J1	1
31	0625060042	BALL BEARING 6004 TN9 C4	1
39	50333020000	IDLER GEAR BUSH. 22X25X11,1 A	2
40	50333040000	STOP DISC 22,2X27,8X1 A	1
41	50333041000	STOP DISC 17,2X26X1 B	1
45	50333045000	STOP DISK 22,2X27,8X1	1
90	50133090000	LOCK RING 22X1,2	2

085233330

C085233331

* NEW PART

X ON DEMAND

ACHTUNG !!!
 Bei Bestellung von Getrieberädern, Markierung beachten.
CAUTION !!!
 When ordering transmission gears, check marking.

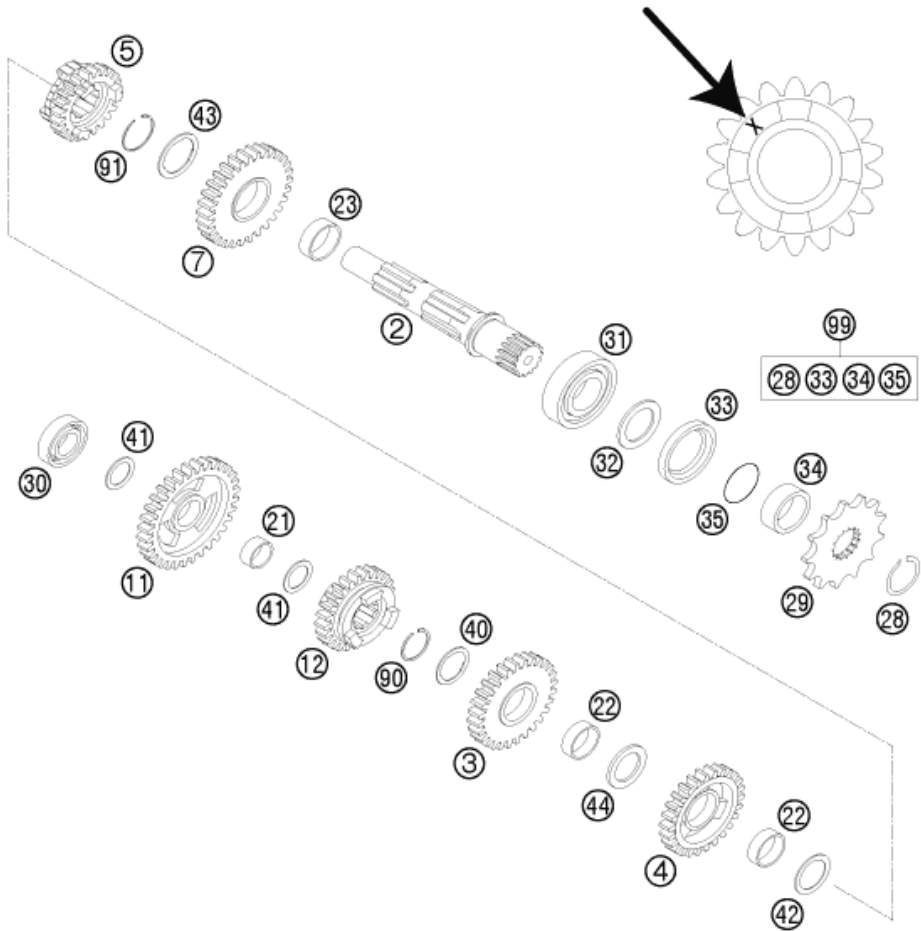

085233360

POS	PARTNUMBER	PARTNAME	PIECE
2	50333002000	COUNTER SHAFT 125/200 '98	1
3	50333003100	IDLE G.3RD G.28-T "3S28H" 04	1
4	50333004000	IDLE G.4TH G.26-T "4S26" '98	1
5	50333005500	SLIDING GEAR 6TH G. "6E20H" 04	1
7	50333006100	IDLER G. 2ND G. 31-T "2G31" '98	1
11	50333011300	IDLER G. 1ST G. 33-T "1G33" '98	1
12	52333012100	SLIDING G.5TH G.19-T"5G19H" 04	1
21	50333021000	IDLER GEAR BUSHING 17X20X9,7 B	1
22	50333022000	IDLER GEAR BUSHING 22X25X8,1 C	2
23	50333023000	IDLER GEAR BUSHING 25X28X9,7 D	1
28	52033096000	LOCK RING DINO471-25X1,64SD	1
29	50033029013	FRONT SPROCKET 13-T	x
29	50033029014	FRONT SPROCKET 14-T	1
30	0625060031	BALL BEARING 6003 TN9 C4	1
31	0625062054	BALL BEARING 6205 C3 NTN	1
32	56033020000	STOP RING	1
33	0760324571	SHAFT SEAL RING 32X45X7 BSLNBR	1
34	54633014100	SPACER BUSHING 12MM	1
35	0770230020	O-RING 23,00X2,00 NBR70	1
40	50333040000	STOP DISC 22,2X27,8X1 A	1
41	50333041000	STOP DISC 17,2X26X1 B	2
42	50333042000	STOP DISK 22,2X28X1 C	1
43	50333043000	STOP DISC 25,2X32X1	1
44	50333044000	STOP DISC 22,2X30X2,5	1
90	50133090000	LOCK RING 22X1,2	1
91	0417025000	CIRCLIP SW25	1
99	00050000943	COUNTER SHAFT REP.KIT 125-200	x

C145243360

* NEW PART X ON DEMAND

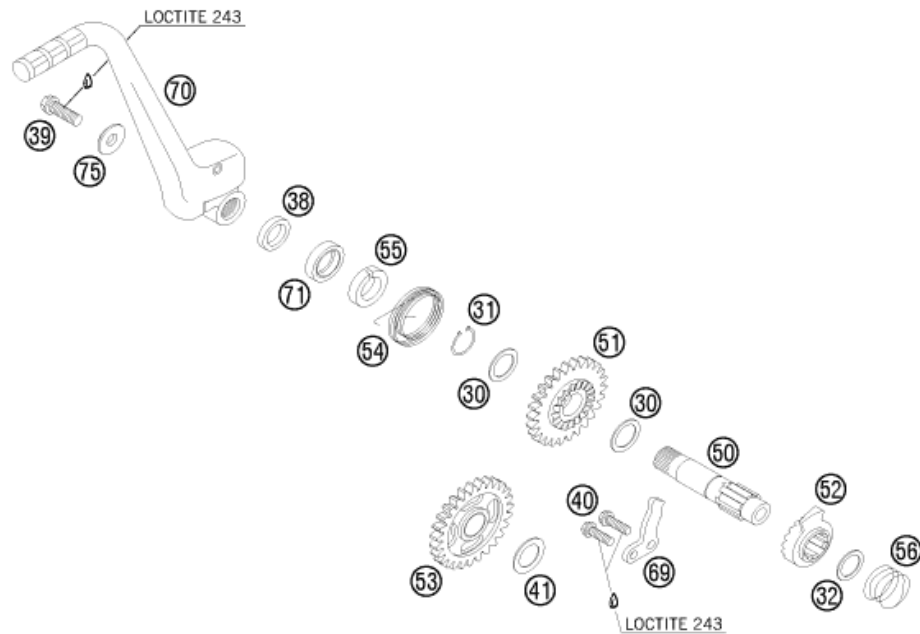

POS	PARTNUMBER	PARTNAME	PIECE
30	50333030000	STOP DISK 17,2X24X1	2
31	0471170010	CIRCLIP DIN0471-17X1	1
32	0988162210	THRUST WASHER DIN0988-16X22X1	1
38	50333038100	SPACER BUSHING 16X23X26X6,1	1
39	0025080206	HH COLLAR SCREW M8X20 TX40	1
40	0025060166	HH COLLAR SCREW M6X16 TX30	2
41	50333041000	STOP DISC 17,2X26X1 B	1
50	50333050000	KICKSTARTER SHAFT 125/200'98	1
51	50333051026	KICKSTART.GEAR 26-T 125/200'98	1
52	50333052000	KICKSTARTER RATCHET	1
53	50333053127	INTERMEDIATE GEAR 27-T 04	1
54	50333054000	KICKSTARTER SPRING 2,6MM '98	1
55	50333055000	DRIVING HUB 125/200'98	1
56	50333056000	SPRING 1,4MM '98	1
69	50333069000	STOP MET.SHEET 4MM 125/200'98	1
70	50333070244	KICK STARTER CPL.	1
71	0760172870	SHAFT SEAL RING 17X28X7 B	1
75	50333075000	WASHER 8,2X22X4,5 '98	1

085033390

C125033392

* NEW PART

X ON DEMAND

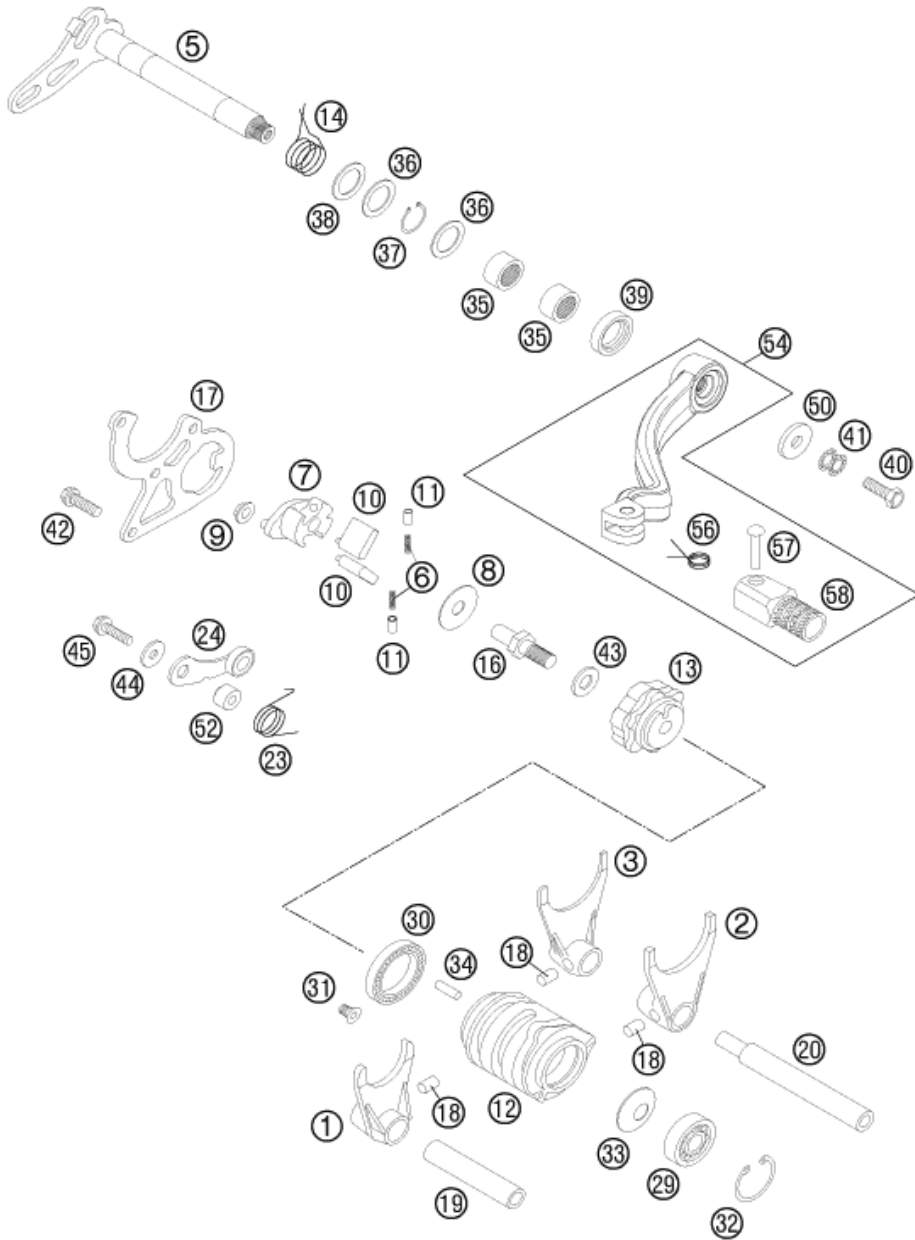

135233410

POS	PARTNUMBER	PARTNAME	PIECE
1	50334001200	SHIFTING FORK 5TH/6TH GEAR	1
2	50334002200	SHIFTING FORK 2ND/4TH GEAR	1
3	50334003200	SHIFTING FORK 1ST/3RD GEAR	1
5	50334005100	SHIFTING SHAFT CPL.	1
6	50334007052	SPRING FOR RATCHET 0,5X11,5	2
7	50334007000	RATCHET SUPPORT 125/200'98	1
8	50334007054	STOP DISK 8,2X26X0,7	1
9	50334007053	BUSHING 6X8X12X4,5	1
10	50334007150	SHIFTING RATCHET 125/200	2
11	50334007051	PRESSURE END PAD 4,1X5,6X8,4	2
12	50334012300	SHIFTING DRUM 06	1
13	50334013000	LOCATING DRUM 125/200'98	1
14	50334014000	RETURN SPRING 3MM	1
16	50334016000	SPECIAL SCREW M8X21,5 WS=12	1
17	50334017000	SHIFTING GATE 3MM 125/200'98	1
18	0402061000	NEEDLE ROLLER ZRB 6X10	3
19	50334019000	SHIFTING ROD DRIVE 11,8X67,5	1
20	50334020000	SHIFT. ROD DRIVE END 11,8X94,5	1
23	50334023000	LOCATING LEVER SPRING 2,5MM'98	1
24	50334024144	LOCATING LEVER CPL. 08	1
29	0625060006	BALL BEARING 6000 RS1 C3	1
30	0625618050	BALL BEARING 61805 C3	1
31	0991050102	FLAT H.SCEW DIN7991-M5X10 10.9	1
32	0472260120	LOCK RING DIN0472-26X1,2	1
33	0093251209	SPRING WASHER 12,2X25X0,9	1
34	0402040980	NEEDLE ROL.DIN5402 NRB 4X9,8	1
35	54632095000	NEEDLE BEAR.HK 1412 14X20X12	2
36	49033031000	STOP DISK 14,3X20X1	2
37	0471140100	LOCK WASHER DIN0471-14X1	1
38	49033031015	STOP DISK 14,2X22X1,5	1
39	0760142460	SHAFT SEAL RING 14X24X6 B	1
40	0025060166S	HH COLLAR SCREW M6X16 ISA 30	1
41	50233041000	PAIR OF WASHERS M 6 NORDLOCK	1
42	0025060166	HH COLLAR SCREW M6X16 TX30	3
43	0125080003	WASHER DIN0125-A 8 4	1
44	0349000050	WASHER DIN7349-5X15X2	1
45	0025050206	HH COLLAR SCREW M5X20 TX30	1
50	50232050001	STEEL WASHER 6,4X17X3	1

C155033411

* NEW PART

X ON DEMAND

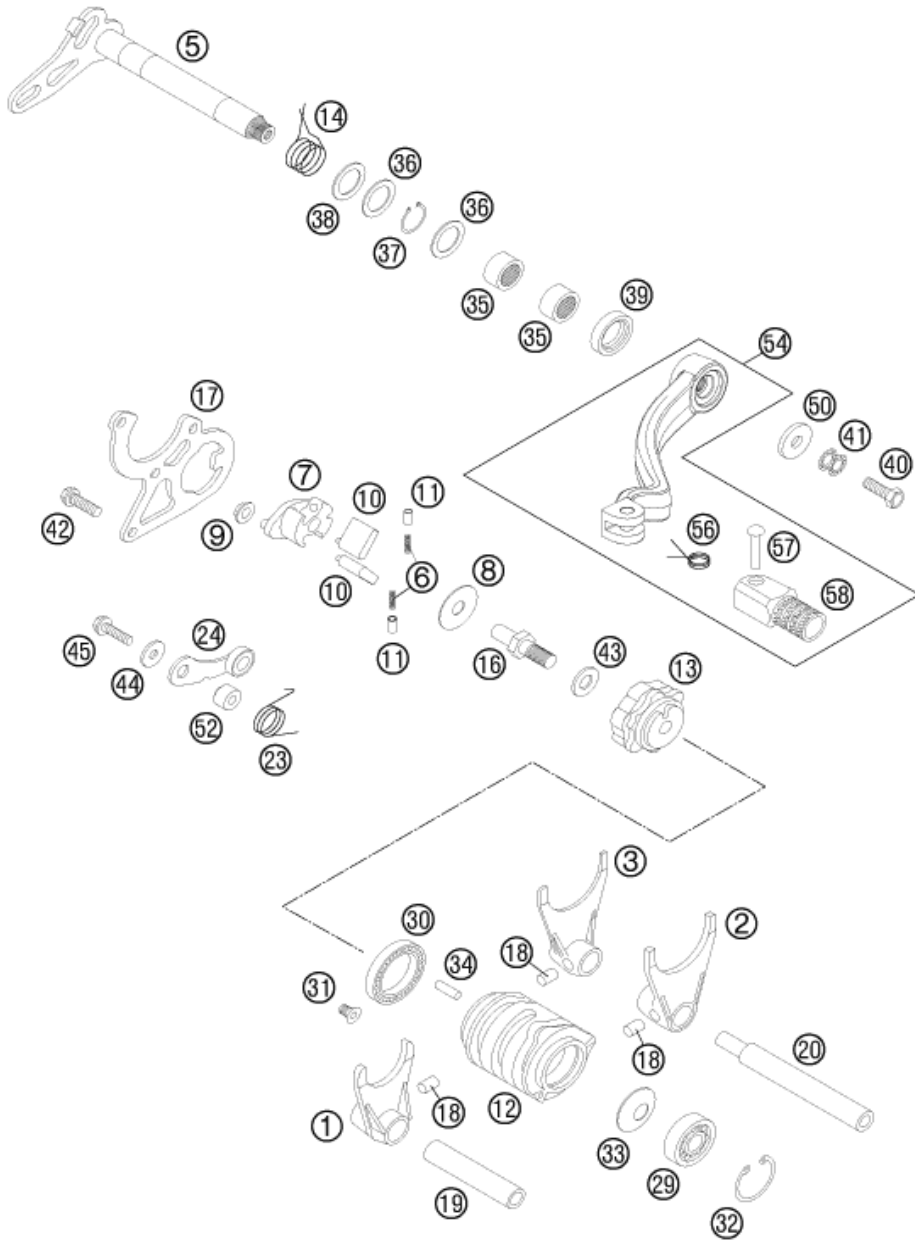

POS	PARTNUMBER	PARTNAME	PIECE
52	54634052300	SLEEVE FOR LOCKING LEVER	1
54	54734031000	SHIFT LEVER CPL. 2-STROKE 2001	1
56	54634032100	SHIFTING LEVER SPRING 250	1
57	54634031050	BOLT 6X25 FOR SHIFT LEVER	1
58	54634131000	STEP PLATE FOR SHIFT LEVER 250	1

135233410

C155033411

* NEW PART

X ON DEMAND

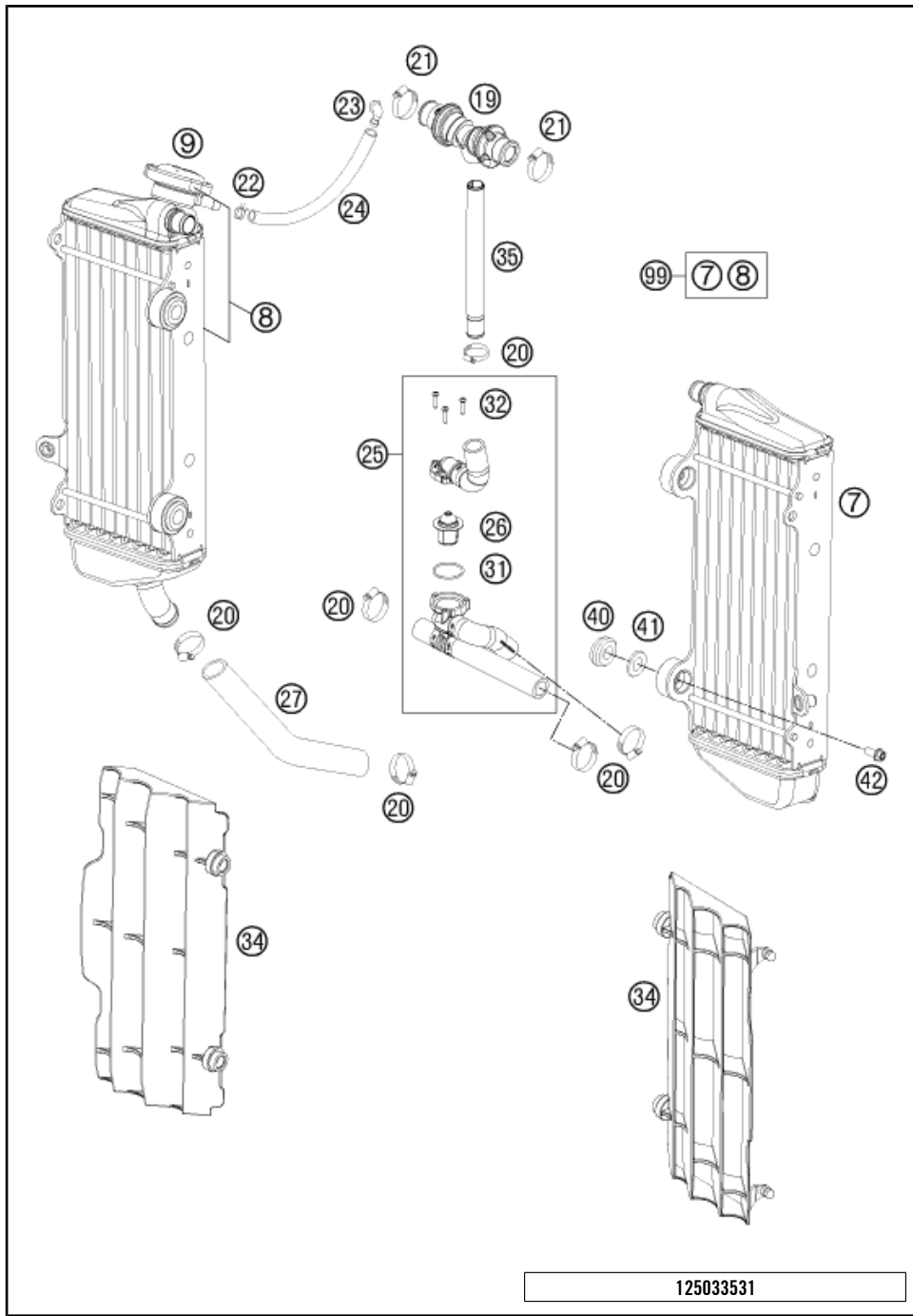

POS	PARTNUMBER	PARTNAME	PIECE
7	54835007400	RADIATOR L/S "15562U" 14	1
8	54835008600	RADIATOR R/S "15620U" 14	1
9	77335016000	RADIATOR CAP SMALL 1,8 BAR	1
19	77235071044	Y-CONNECTOR CPL.	1
20	10001020000	HOSE CLAMP GEMI 18-29	6
21	42013037400	HOSE CLAMP NORMA 14/24	2
22	59007017000	CLAMP YDNAC 10096F (9,6MM)	1
23	50303089000	ANGLE PIECE '97	1
24	50335030001	PVC-HOSE 6X9	x
25	52335626033	RADIATOR HOSE W. THERMO. '14	1
26	59435117000	% THERMOSTAT 70°C	1
27	50335027000	RADIATOR HOSE 18X25 125/200'98	1
31	0770320020	O-RING 32,00X2,00	1
32	0016040183	SCREW FOR PLASTIC D=4X18	3
34	7733503400030	RADIATOR PROTECTION BLACK 07	2
35	77235073000	HOSE CONNECTOR L=172,5	1
40	41001052000	RUBBER SLEEVE D=12MM	4
41	77335001000	WASHER FOR RADIATOR 08	4
42	0023060123	COLLAR SCREW M6X12 TX	4
99	00050000134	RADIATOR KIT 10-14	x

* NEW PART X ON DEMAND

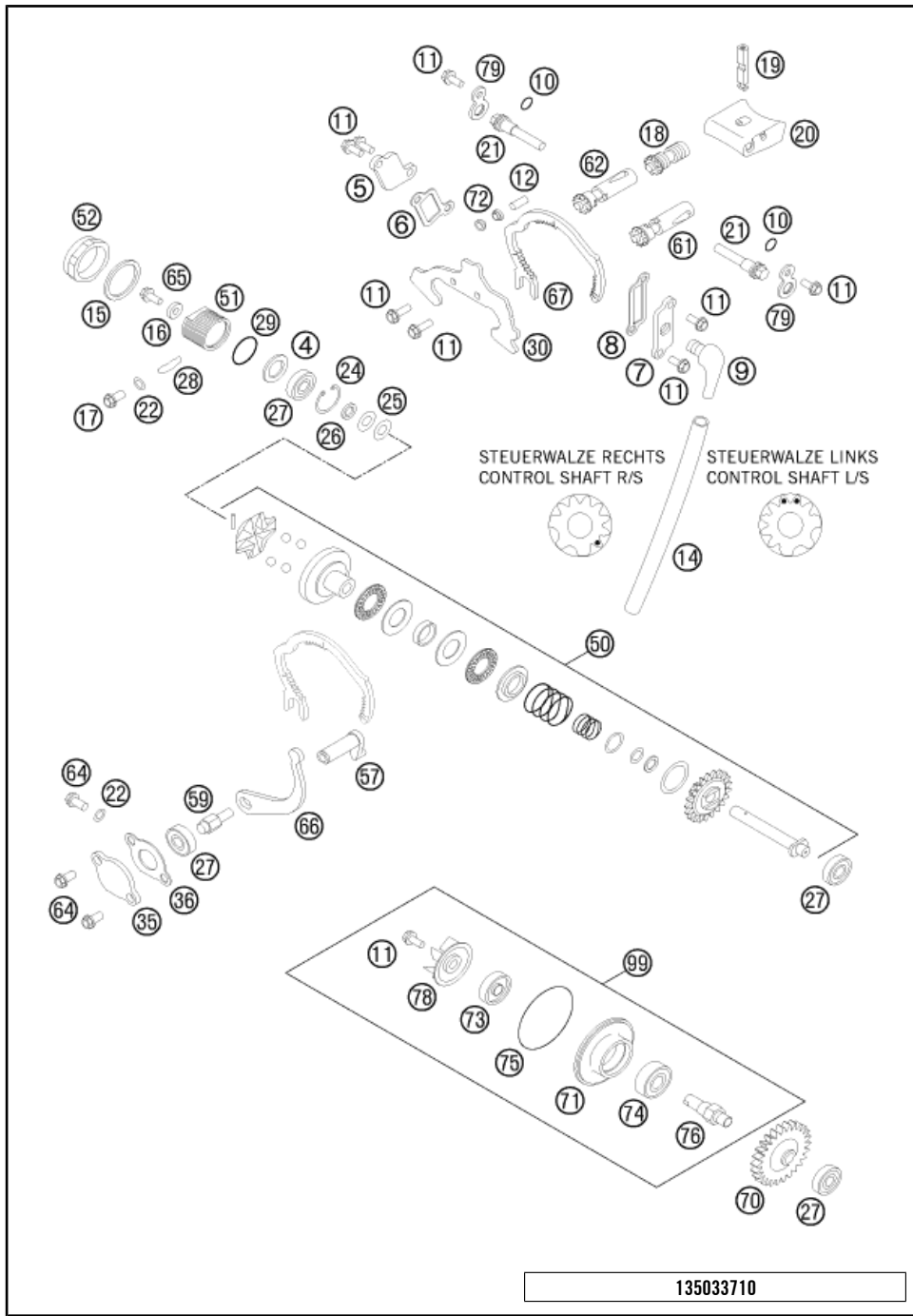

POS	PARTNUMBER	PARTNAME	PIECE
4	49033031015	STOP DISK 14,2X22X1,5	1
5	50337005000	SIDE COVER R/S '98	1
6	50337006000	GASKET SIDE COVER R/S	1
7	50337007100	SIDE COVER LEFT M10 2002	1
8	50337008000	GASKET SIDE COVER L/S	1
9*	51030022000	ANGLE PIECE 90 DEGREE M10X1	1
10	0770008020	O-RING 8,00X2,00 NBR	2
11	0014050123	HH COLLAR SCREW M 5X12 WS=6	9
12	0402051600	NEEDLE ROL. DIN5402 NRB 5X15,8	3
13	0025050126	HH COLLAR SCREW M5X12 TX30	1
14	50332095200	TUBE RUBBER 6X9 DVOH 200MM	1
15	0603262322	CU-SEAL RING DIN7603-26X32X2	1
16	50337050064	WASHER 5,2 X 12 X 3	1
17	0025060106	HH COLLAR SCREW M6X10 TX30	1
18	52337018044	ECCENTRIC FOR CRANKBOLT 200'98	1
19	52337019000	CRANK BOLT F.CONTROL FL.200'98	1
20	52337020000	CONTROL FLAP 200 '98	1
21	51237021000	AXLE FOR CONTRIL FLAP 01	2
22	0603061001	CU-SEAL RING DIN7603-6X10X1	3
24	0472022100	CIRCLIP DIN0472-22X1	1
25	0093821606	WASHER DIN2093-8,2X16X0,6	2
26	50337050063	SPACER BUSHING 8X12X2,3	1
27	0625006082	BALL BEARING 608 RS C3	4
28	00099300011	O-RINGSTRING 4MM NBR 70 PER/M	0
29	0770160030	O-RING 16,00X3,00 NBR 70	1
30	52337030000	SHEET METAL GUIDE 3MM 200'98	1
35	50337035000	CLOSING COVER '98	1
36	50337035050	CLOSING COVER GASKET 1MM	1
50	52337050044	CENTRIFUGAL TIMER CPL. 200'98	1
51	50337050062	BUSHING HOLDER M 26X1 '98	1
52	50337050061	CLOSING NUT M 26X1 WS=30	1
57	50337057000	CONTROL LEVER 125/200'98	1
59	50337059000	CONTROL SHAFT M 6 WS=10 '98	1
61	52337061144	CONTROL SHAFT CPL.L/S 200 2001	1
62	52337062144	CONTROL SHAFT CPL.R/S 200 2001	1
64	0025060126	HH COLLAR SCREW M6X12 TX30	4
65	0025050126	HH COLLAR SCREW M5X12 TX30	1
66	50337066000	LEVER F. CONTROL SEGMENT '98	1

135033710

C155243710

* NEW PART X ON DEMAND

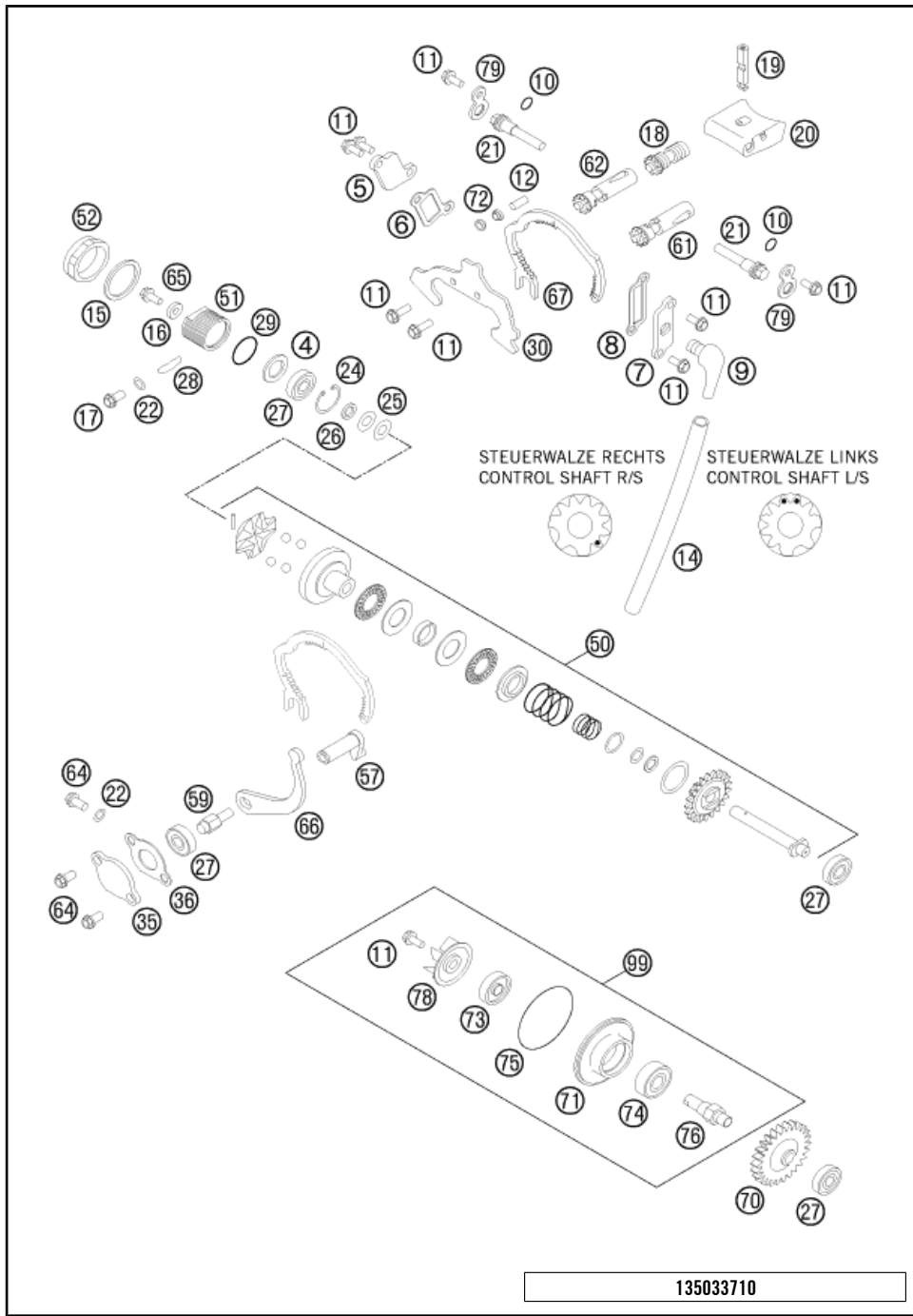

POS	PARTNUMBER	PARTNAME	PIECE
67	52337067000	CONTROL SHAFT SEGMENT 200'98	1
70	50335054026	DRIVE WHEEL 26-T 125/200'98	1
71	50335056000	BUSHING SUPPORT WATER PUMP '98	1
72	50337072000	ROLLER GUIDE 5X6,1X8X4 '98	6
73	0760082472	SHAFT SEAL RING 8X24X7 A DUO	1
74	0625060001	BALL BEARING 6000/C3	1
75	0770049025	O-RING 49,00X2,50 NBR	1
76	50335054150	WATER PUMP SHAFT	1
78	54835005000	WATER PUMP WHEEL 07	1
79	50337079000	LOCK METAL SHEET 2MM '98	2
99	54835055115	WATER PUMP REP. KIT SX 11-14	x

135033710

C155243710

* NEW PART X ON DEMAND

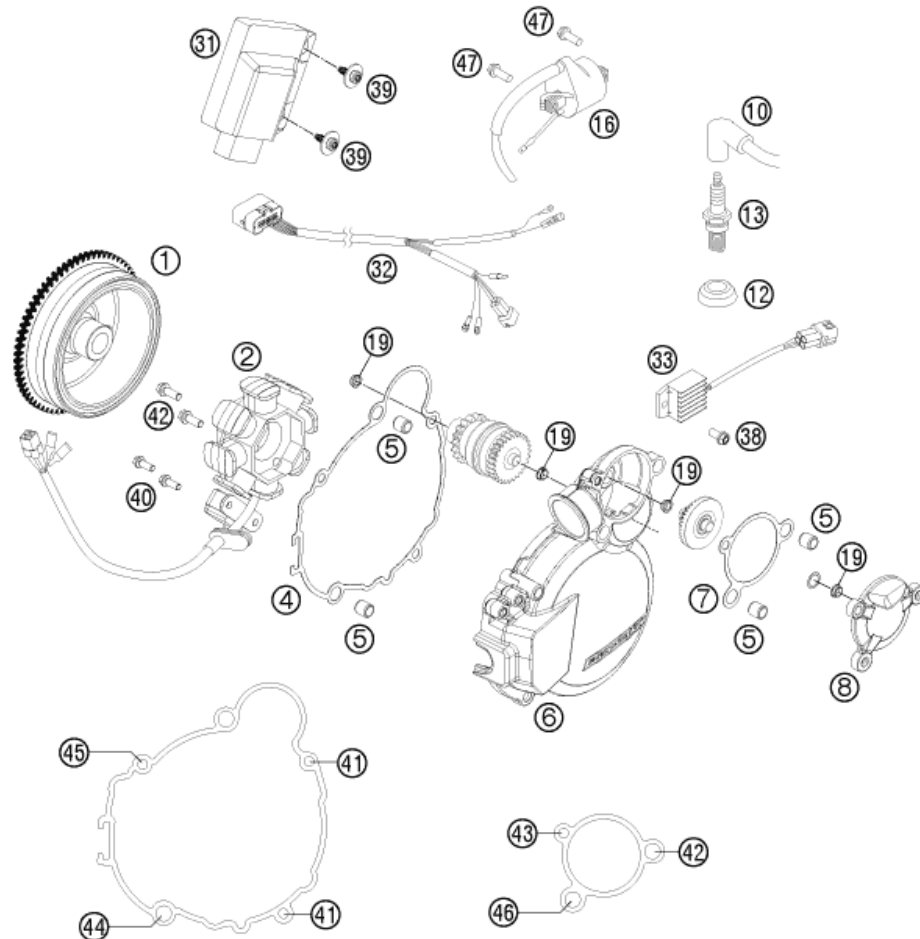

POS	PARTNUMBER	PARTNAME	PIECE
1	55139005000	FLYWHEEL KOKUSAN	1
2	55139004000	STATOR KOKUSAN	1
4	52430040000	GASKET IGNITION COVER E-START	1
5	49030090000	DOWEL 9,8 X 7 X 10	4
6	52430002000	IGNITION COVER E-START	1
7	52430041000	GASKET IGNITION COVER OUTSIDE	1
8	52430045000	IGNITION COVER OUTSIDE E-START	1
10	47039090000	SPARK PLUG CAP NGK REINFORC.04	1
12	50231012000	SEALING CUP FOR SPARK PLUG	1
13	54331093310	SPARK PLUG NGK BR8EG	1
16	59039006000	IGNITIONCOIL "IG5128"	1
19	55140030100	COLLAR BUSHING	4
31	52339131100	ELEKTRONICBOX 200 XC/EXC 12	1
32	54839032200	WIRING HARNESS FOR CDI 2-ST.07	1
33	80011034000	VOLTAGE REGULATOR 04	1
38	0023060123	COLLAR SCREW M6X12 TX	1
39	0081645121	EJOT DELTA PT SCREW 45X12-Z	2
40	0014050123	HH COLLAR SCREW M 5X12 WS=6	2
41	0025060206	HH COLLAR SCREW M6X20 TX30	2
42	0025060256	HH COLLAR SCREW M6X25 TX30	3
43	0025060306	HH COLLAR SCREW M6X30 TX30	1
44	0025060356	HH COLLAR SCREW M6X35 TX30	1
45	0025060556	HH COLLAR SCREW M6X55 TX30	1
46	0025060756	HH COLLAR SCREW M6X75 TX30	1
47	0026060186	COLLAR SCREW M6X18 ISA30	2

135233910

C145243910

* NEW PART

X ON DEMAND

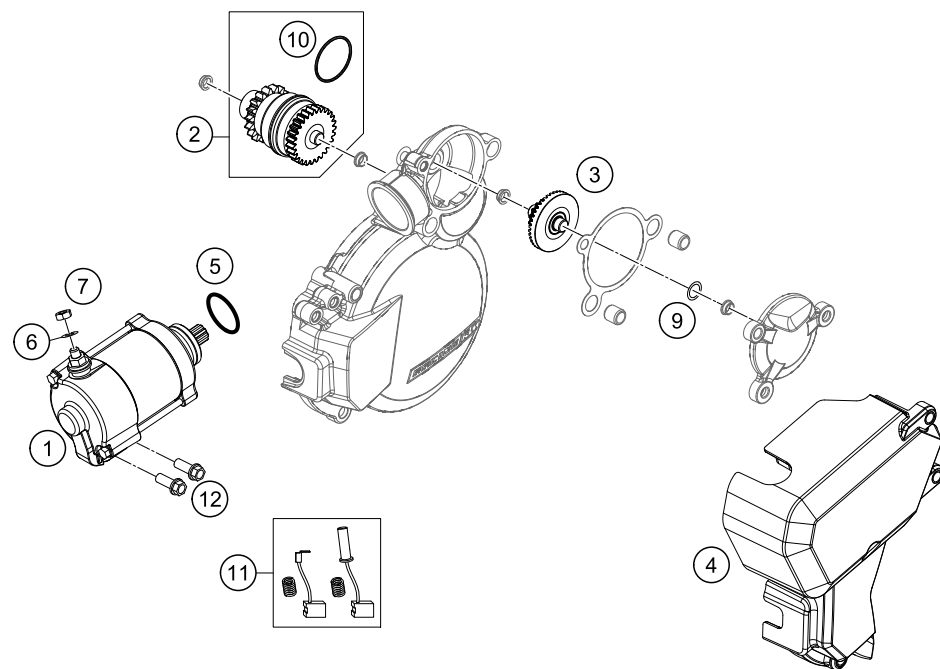

POS	PARTNUMBER	PARTNAME	PIECE
1	55140001100	STARTER MORIC	1
2	55140026100	BENDIX	1
3	55140022100	CROWN WHEEL E-STARTER	1
4	52440040000	STARTER DRIVE COVER CPL.	1
5	0770250030	O-RING 25,00X3,00 NBR 70	1
6	0125060003	WASHER DIN0125-A 6,4	1
7	0985060003	SELF LOCK. NUT DIN0985-M 6	1
9	0988081401	THRUST WASHER 8X14X0,1	x
9	0988081402	THRUST WASHER 8X14X0,2	x
9	0988081403	THRUST WASHER 8X14X0,3	x
9	0988081405	THRUST WASHER 8X14X0,5	x
10	55140027000	BENDIXSPRING	1
11	55140002144	BRUSH SET FOR STARTER ONLY FOR 55140001100	1
12	0025060256	HH COLLAR SCREW M6X25 TX30	2

155244010

C155244010

* NEW PART X ON DEMAND

WWW.KTM.COM



KTM Sportmotorcycle GmbH
5230 Mattighofen, Austria
www.ktm.com



KTM_POWERPARTS

KTM_POWERWEAR

KTM_ORIGINAL SPARE PARTS

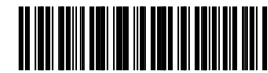

3CM0820350EN

Art. Nr.: 3CM0820350EN 5. Mai 2015