

450 SX-F 2016

ART.-NR.: 3CM089570PEN

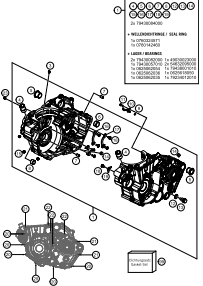
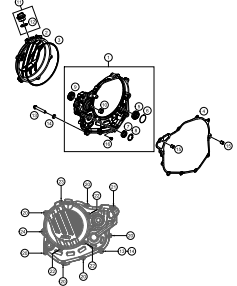
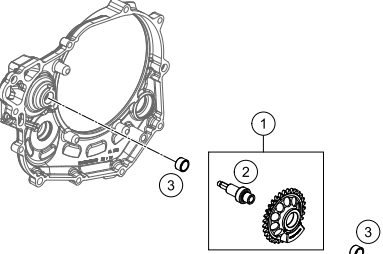
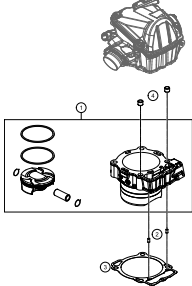
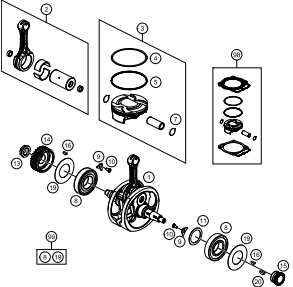
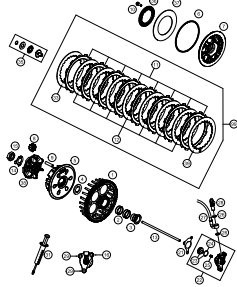
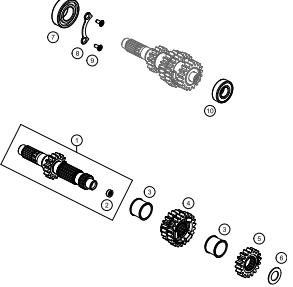
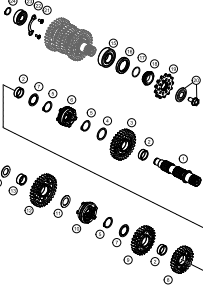
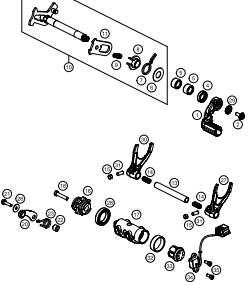
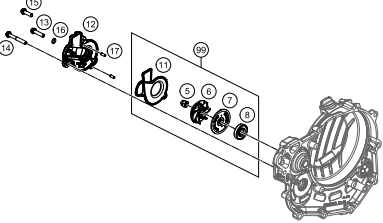
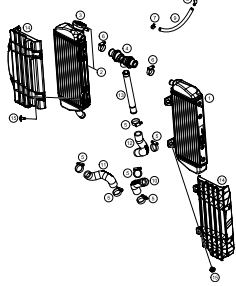
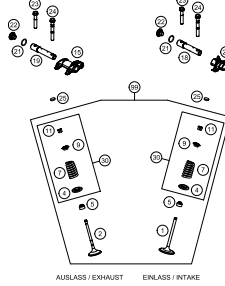
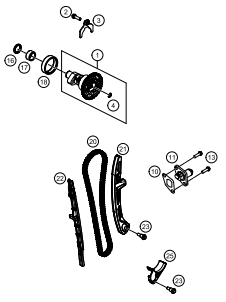
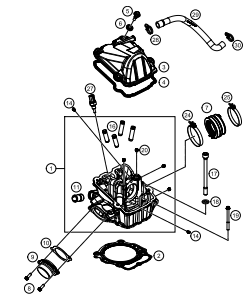
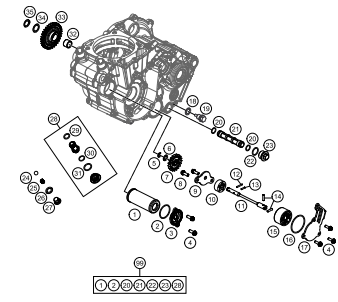
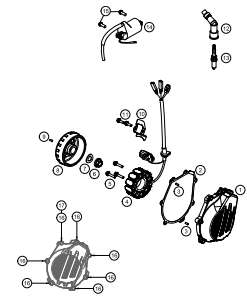
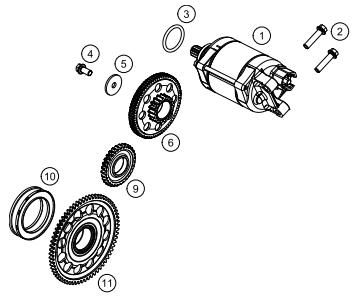
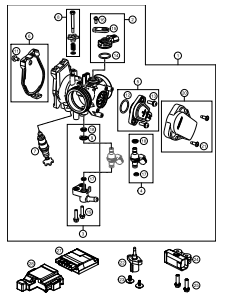

<p>ENGINE CASE</p>  <p>3</p>	<p>CLUTCH COVER</p>  <p>4</p>	<p>BALANCER SHAFT</p>  <p>5</p>	<p>CYLINDER</p>  <p>6</p>
<p>CRANKSHAFT, PISTON</p>  <p>7</p>	<p>CLUTCH</p>  <p>8</p>	<p>TRANSMISSION I - MAIN SHAFT</p>  <p>9</p>	<p>TRANSMISSION II - COUNTERSHAFT</p>  <p>10</p>
<p>SHIFTING MECHANISM</p>  <p>11</p>	<p>WATER PUMP</p>  <p>12</p>	<p>COOLING SYSTEM</p>  <p>13</p>	<p>VALVE DRIVE</p>  <p>14</p> <p>AUSLASS / EXHAUST EINLASS / INTAKE</p>

<p>TIMING DRIVE</p>  <p>16</p>	<p>CYLINDER HEAD</p>  <p>17</p>	<p>LUBRICATING SYSTEM</p>  <p>18</p>	<p>IGNITION SYSTEM</p>  <p>19</p>
<p>ELECTRIC STARTER</p>  <p>20</p>	<p>THROTTLE BODY</p>  <p>21</p>		
<div style="display: flex; align-items: center;"> <div style="background-color: #cccccc; width: 50px; height: 100px; display: flex; align-items: center; justify-content: center; margin-right: 20px;"> ! </div> <div> <p>All information contained is without obligation. KTM Sportmotorcycle GmbH particularly reserves the right to modify any equipment, technical specifications, prices, colors, shapes, materials, services, service work, constructions, equipment and the like so as to adapt them to local conditions or to cancel any of the above items, all without previous announcement and without giving reasons. KTM may stop manufacturing certain models without previous notice. KTM shall not be held liable for any deviations of availability and/or ability to deliver, illustrations, descriptions, printing and/or other errors. The illustrated models partly contain extra equipment, which is not applied to standard models.</p> <p>© by KTM Sportmotorcycle GmbH, Mattighofen AUSTRIA; All rights reserved; Reprint, also in extracts, with written allowance of KTM Sportmotorcycle GmbH, Mattighofen only.</p> </div> </div>			

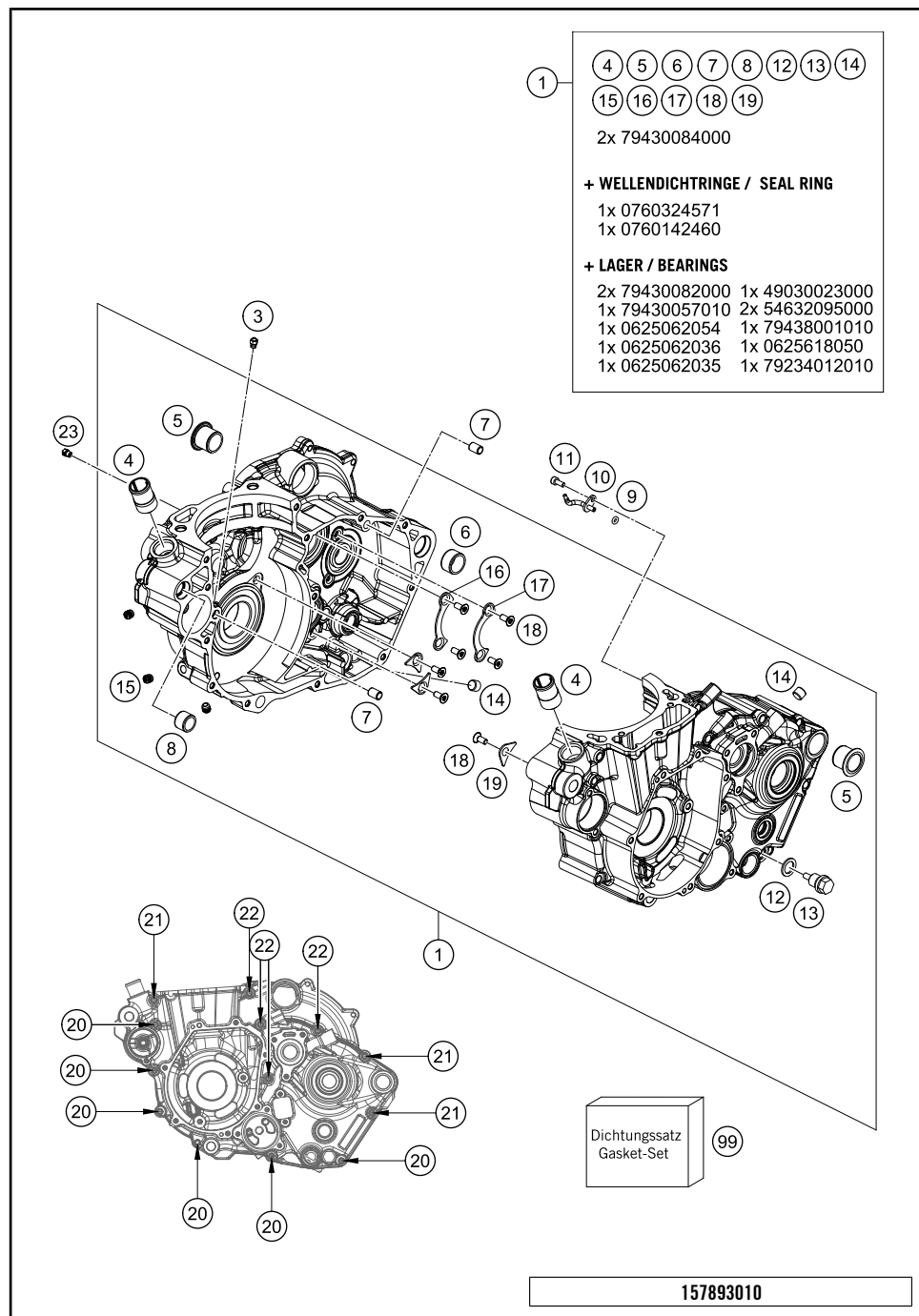

POS	PARTNUMBER	PARTNAME	PIECE
1*	79430000044	ENGINE CASE CPL.	1
3	60030063070	OIL JET 70 M5	1
4*	58030010200	SCREW IN NOZZLE M20X1,5	2
5	75030010100	CASE BUSH	2
6	54830027000	DOWEL 21X12 03	1
7	59030023000	DOWEL 6X8X11,5	2
8	51030026100	DOWEL 17 X 13 X 12	1
9	0770035020	O-RING 3,5X2,00 NBR	1
10	81230064000	OIL JET ANGLED 70	1
11	0912040103	AH.SCREW DIN0912-M 4X10	1
12	58038022000	CU-SEAL RING DIN7603-12X18X1,5	1
13	58030021000	OILDRAIN PLUG W.MAG. M 12X1,5	1
14*	0906100100	PLUG DIN0906-M10X1	2
15*	59030296000	SCREW PLUG	3
16	78033032000	TAB WASHER BEARING MAIN SHAFT	1
17	78033132000	TAB WASHER BEARING COUNT.SHAFT	1
18	0019050121S	INT. TORX FLAT HEAD M5X12 T25	7
19*	75030085000	RETAINING PLATE F. CS BEARING	3
20	0025060606	HH COLLAR SCREW M6X60 TX30	6
21*	0025060706	HH COLLAR SCREW M6X70 TX30	3
22	0025060806	HH COLLAR SCREW M6X80 TX30	4
23*	60030063050	OIL JET 50 05	1
99	79430099000	GASKET SET 450 SX-F	x

157893010

C167943010

* NEW PART X ON DEMAND

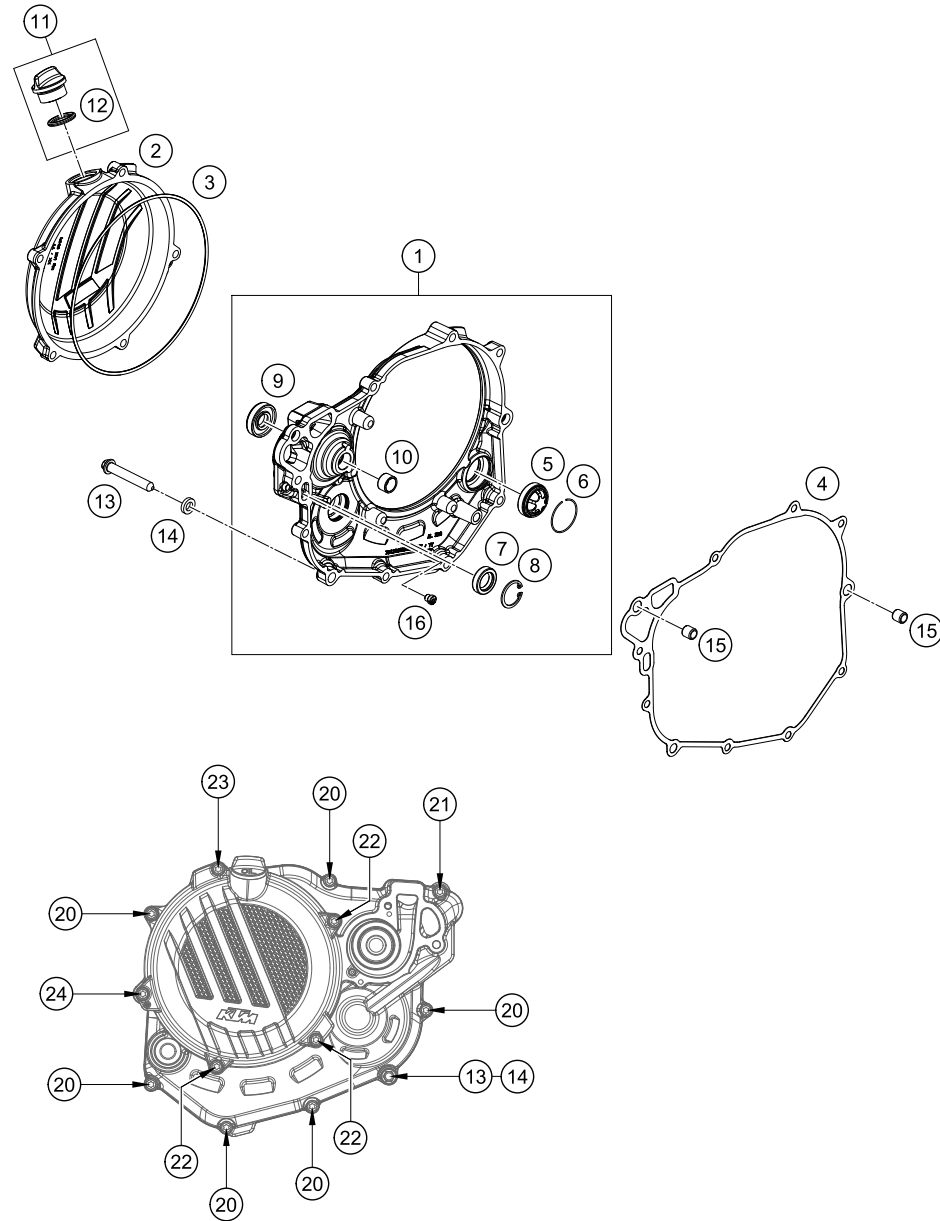

POS	PARTNUMBER	PARTNAME	PIECE
1*	79430001044	CLUTCH COVER CPL.	1
2*	7943002600015	OUTER CLUTCH COVER	1
3	78130027000	GASKET - CLUTCH OUTER COVER	1
4*	79430025000	INNER CLUTCH COVER GASKET	1
5*	59030019200	OIL SIGHT GLASS	1
6	61030019050	CIRCLIP OIL LEVEL GLASS O3	1
7	0760142460	SHAFT SEAL RING 14X24X6 B	1
8*	0472024120	CIRCLIP DIN0472-24X1.2	1
9	0760123073	SHAFT SEAL RING 12X30X7 PTFE	1
10*	79430057010	FRICTION BEAR. BUSH BALANC.SH.	1
11*	79430020033	OIL FILLER CAP M24x3 WITH O-R	1
12	0770191015	O-RING 19,00X3,00 NBR	1
13	78030080000	LOCATING SCREW	1
14	58030081000	CU-SEAL RING 8 X 14 X 3	1
15	49030090000	DOWEL 9,8 X 7 X 10	2
16	57031523145	MAIN JET 145	1
20	0025060256	HH COLLAR SCREW M6X25 TX30	6
21*	0025060306	HH COLLAR SCREW M6X30 TX30	1
22*	0025060206	HH COLLAR SCREW M6X20 TX30	3
23*	0025060456	HH COLLAR SCREW M6X45 TX30	1
24*	0025060506	HH COLLAR SCREW M6X50 TX30	1

157893020

C167943020

* NEW PART

X ON DEMAND

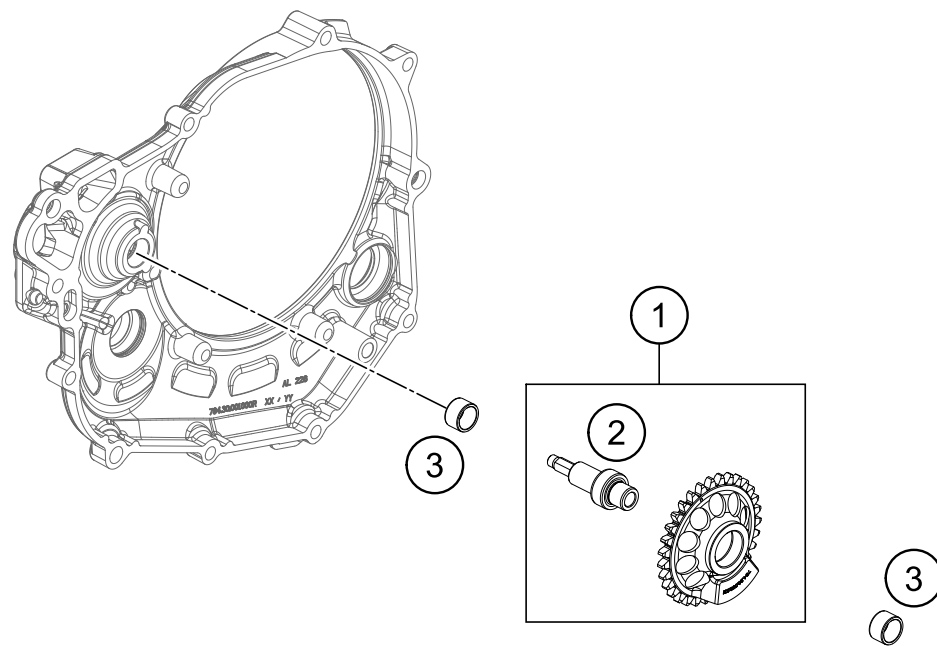

POS	PARTNUMBER	PARTNAME	PIECE
1*	79430057000	BALANCER SHAFT CPL.	1
2*	79430057001	BALANCER SHAFT	1
3*	79430057010	FRICTION BEAR. BUSH BALANC.SH.	2

157893030

C157893030

* NEW PART

X ON DEMAND

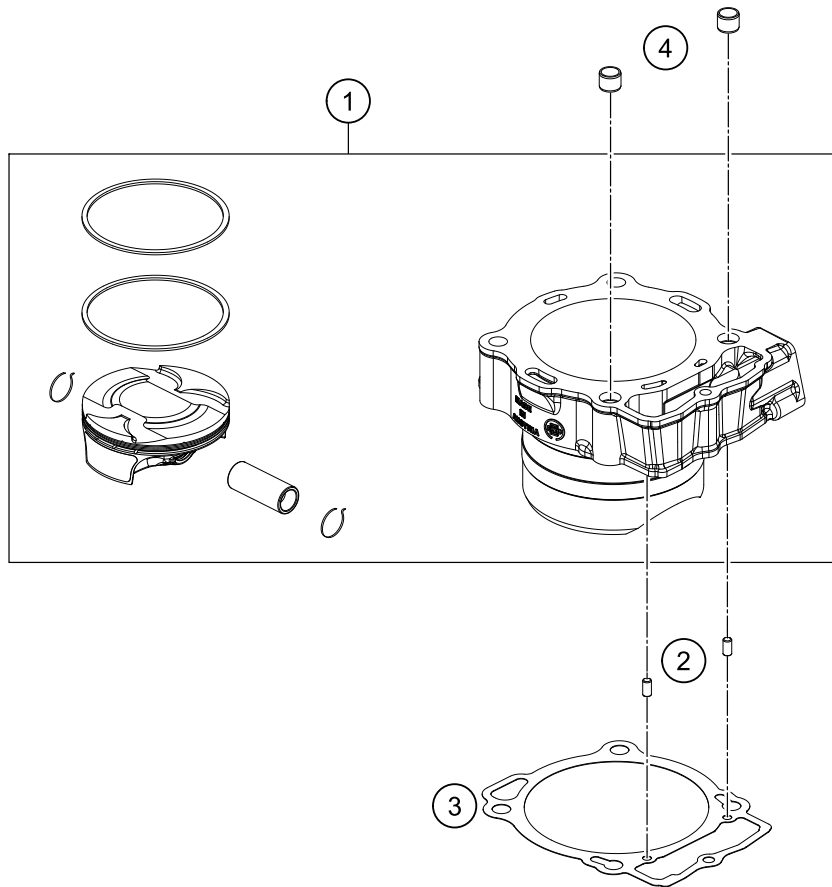
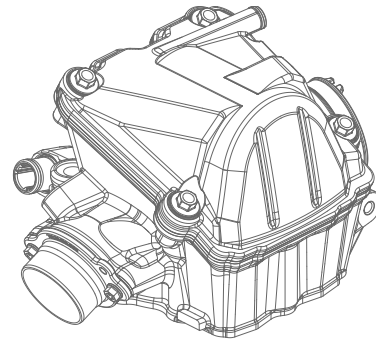

POS	PARTNUMBER	PARTNAME	PIECE
1*	79430038000	CYLINDER + PISTON CPL.	1
2*	0402050980	NEEDLE ROLLER DIN5402 5X9,8	2
3*	79430035000	CYLINDER BASE BASKET	1
4	58530014100	DOWEL BUSHING 10,2X12,5X10	2

157893040

C157893041

* NEW PART

X ON DEMAND

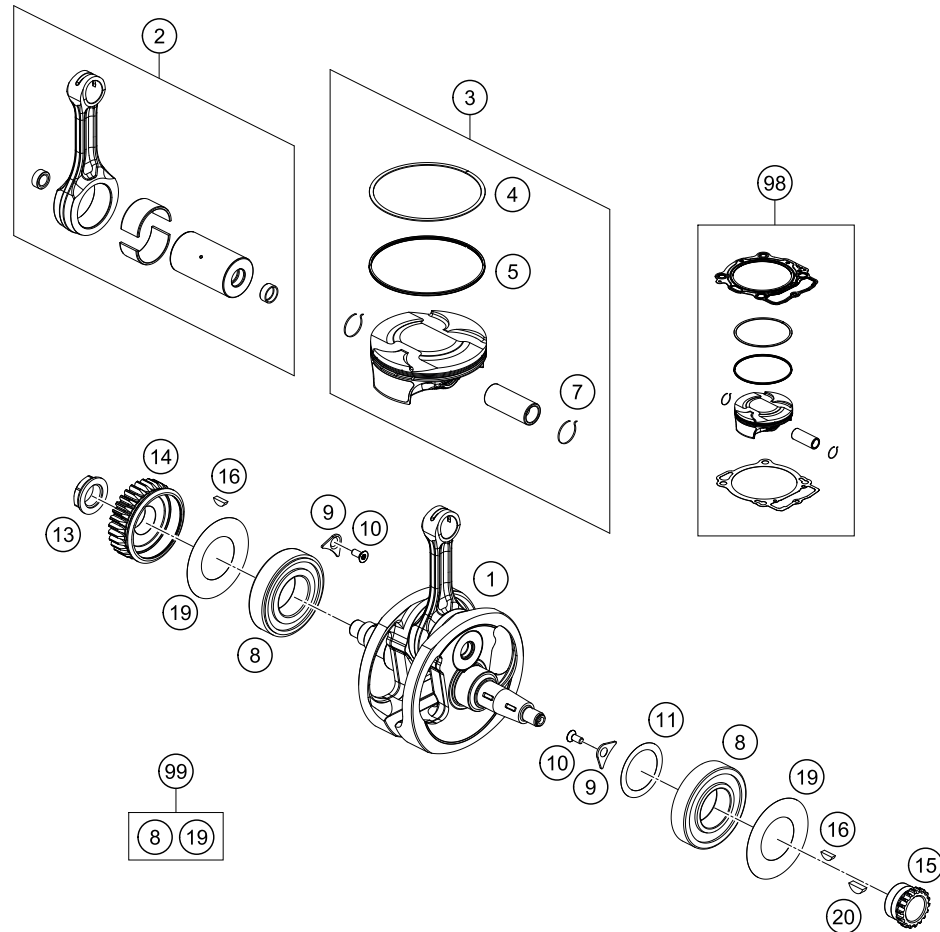

POS	PARTNUMBER	PARTNAME	PIECE
1*	79430018000	CRANKSHAFT CPL.	1
2*	79430015044	CON. ROD. REP. KIT	1
3*	78930007200 I	PISTON I D=95MM	1
3*	78930007200 II	PISTON II D=95MM	1
4	78930030000	COMPRESSION RING	1
5	78930032000	OIL SCRAPER RING	1
7	78930074000	CIRCLIP	2
8*	79430082000	CYLINDER ROLLER BEARING NJ207	2
9*	75030085000	RETAINING PLATE F. CS BEARING	2
10*	0019050121S	INT. TORX FLAT HEAD M5X12 T25	2
11*	56530081000	SHIM WASHER 36X48X0,10	x
11*	56530081100	SHIM WASHER 36X48X0,15	x
11*	56530081200	SHIM WASHER 36X48X0,20 STEEL	x
11*	56530081300	SHIM WASHER 36X48X0,30	x
13	78030029200	NUT PRIMARY WHEEL M20X1,5	1
14*	79432023031	PRIMARY GEAR 31T	1
15	78036014200	TIMING GEAR 18T.	1
16	0888030037	WOODRUFF KEY DIN6888-3X3,7	2
19*	79430084000	BEARING SEAL	2
20	0888030050	WOODRUFF KEY DIN6888-3X5X13	1
98	78930007210 I	PISTON KIT SIZE I 450 SX-F 15	x
98	78930007210 II	PISTON KIT SIZE II 450 SX-F 15	x
99	00050002315	CRANKSHAFT REP.KIT 450 SX-F 15	x

157893060

C157893061

* NEW PART

X ON DEMAND

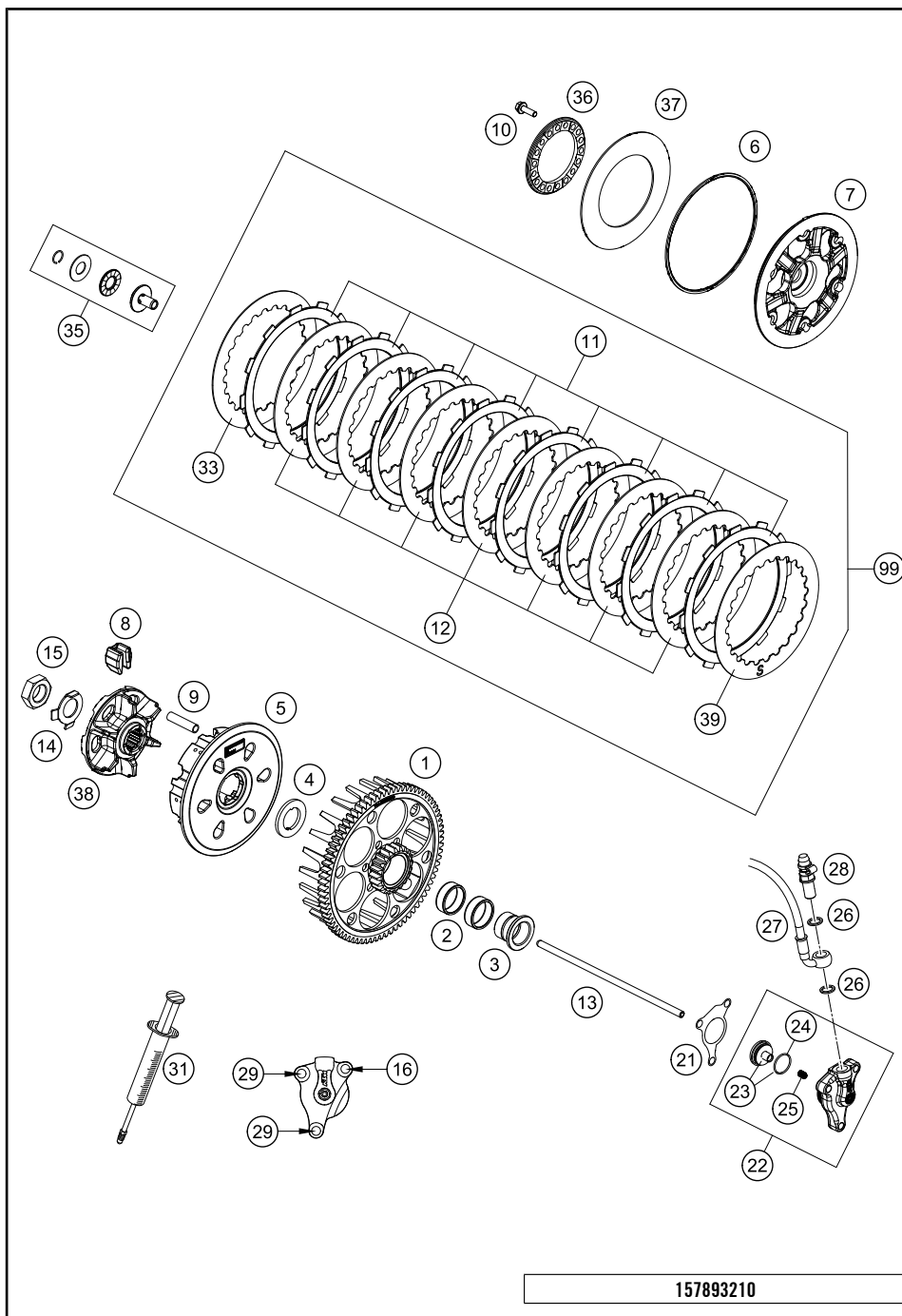

POS	PARTNUMBER	PARTNAME	PIECE
1*	79432001076	CLUTCH CAGE	1
2	0405252910	NEEDLE BEAR K 25X29X10	2
3	78132015100	COLLARSLEEVE	1
4	78932009000	WASHER 22 X 36,5 X 3	1
5*	78132002300	CLUTCH HUB	1
6	78132013000	WASHER 112X118X1.5	1
7*	79432003000	CLUTCH PRESSURE CAP	1
8	78132025100	DAMPING RUBBER	6
9*	77232004000	DRIVING SLEEVE D=7,95 L=38	6
10	0025050166	HH COLLAR SCREW M5X16 TX30	6
11	59032011100	LINING DISC 2MM 04	8
12	59032010200	INTERMEDIATE DISC 1,4MM 2002	7
13*	79432054000	PUSH ROD	1
14	78132018000	TAB WASHER	1
15	0936181505	HEXAGON NUT DIN0936-M18X1,5 R.	1
16	0025060306	HH COLLAR SCREW M6X30 TX30	1
21	59032065000	GASKET FOR SLAVE CYLINDER	1
22	54832061044	OUTPUT CYLINDER CPL. 06	1
23	54832066000	PISTON CPL.	1
24	54832067000	O-RING	1
25	54832069000	PRESSURE SPRING	1
26	0603100141	COPPER GASKET DIN7603-10X14X1	2
27	78132063000	CLUTCH PIPE	1
28	62513020000	BLEEDER SCREW CPL. 05	1
29	0025060206	HH COLLAR SCREW M6X20 TX30	2
31	50329050000	VENT INJEKTION HYDR. CLUTCH	1
33	59032010100	INTERMEDIATE DISC 1MM 2002	1
35	78132057144	PRESSURE PIECE CPL.	1
36	78132006100	SPRING RING	1
37	78932005000	BELLEV. SPR. 71X115X1,6IO=4.74	1
38	78132002111	HUB	1
39	78932010000	INTERMEDIATE DISC 1MM	1
99	78932010033	CLUTCH DISC KIT	1

157893210

C167943210

* NEW PART X ON DEMAND

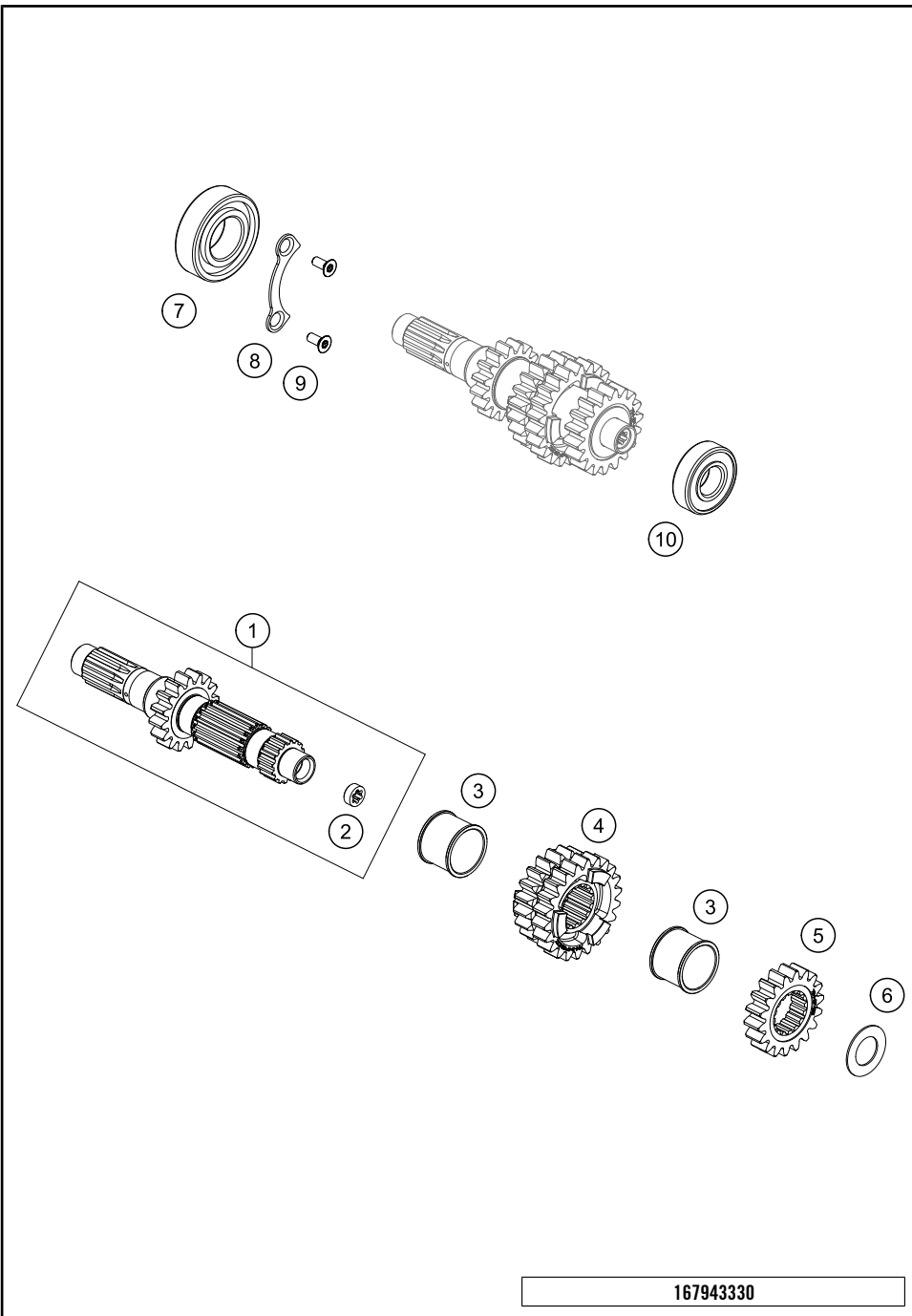

167943330

POS	PARTNUMBER	PARTNAME	PIECE
1*	79433001100	DRIVE SHAFT CPL.	1
2	78033001110	BUSHING	1
3*	79433033000	SPACER SLEEVE	1
4*	79433003000	SLIDING GEAR 3RD/4TH G.	1
5*	79433002000	SOLID GEAR 2ND G.	1
6	56033030000	STOP DISC 17,2X30X1	1
7	0625062054	BALL BEARING 6205 C3 NTN	1
8	78033032000	TAB WASHER BEARING MAIN SHAFT	1
9	0019050121S	INT. TORX FLAT HEAD M5X12 T25	2
10	0625062036	BALL BEARING 6203 RSH C3	1

C167943330

* NEW PART

X ON DEMAND

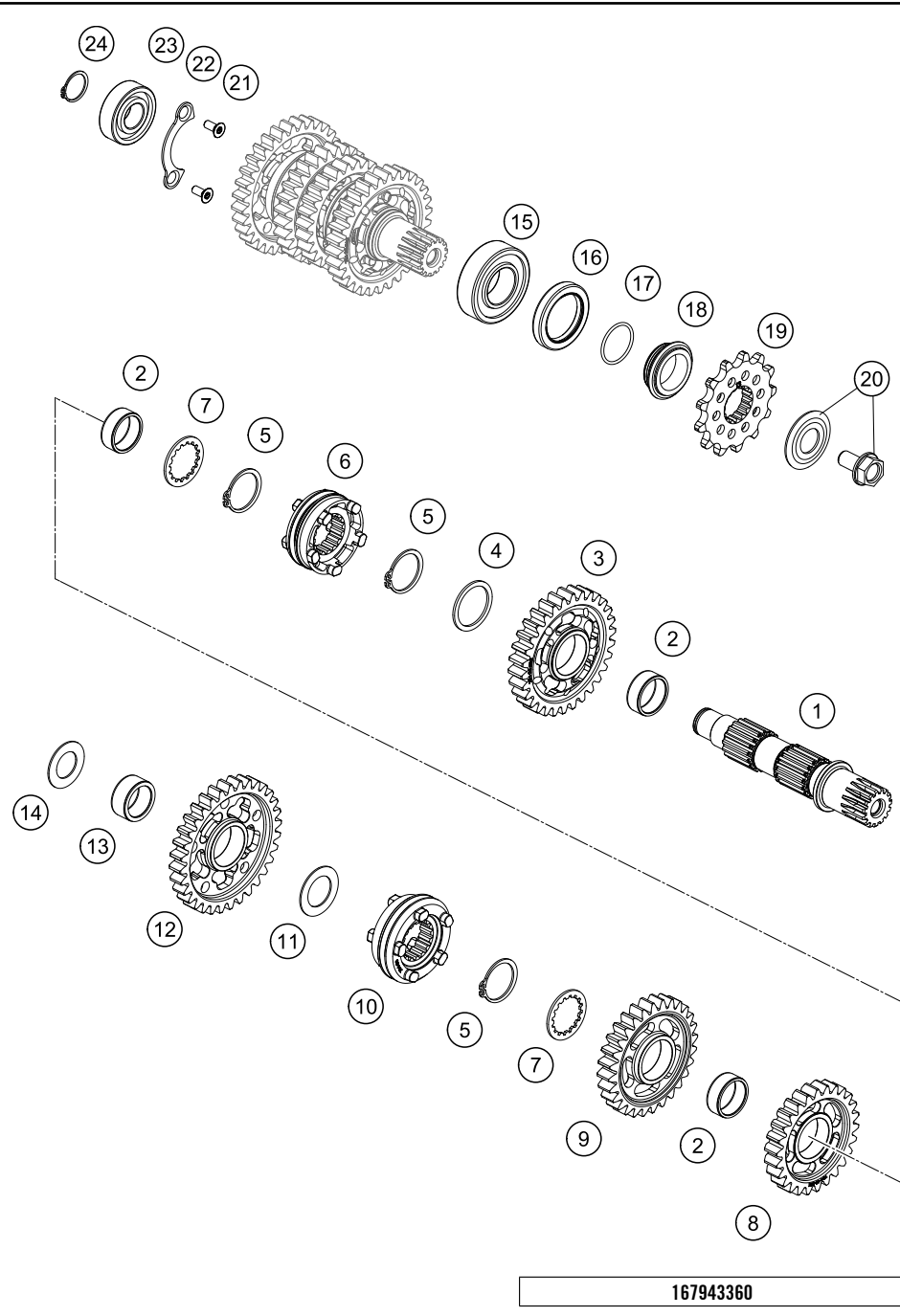

POS	PARTNUMBER	PARTNAME	PIECE
1*	79433010000	DRIVEN SHAFT	1
2	0405222611	NEEDLE BEAR.K 22X26X10 DIVIDED	3
3*	79433012000	IDLER GEAR 2ND G.	1
4	78033031000	STOP DISK 26 X 32 X 1,5	1
5	0471250120	CIRCLIP DIN0471-25X1,2	3
6*	79433017000	SHFIT COLLAR	1
7	78033033000	STOP DISK 23 X 32 X 1,5	2
8*	79433014000	IDLER GEAR 4TH G.	1
9*	79433013000	IDLER GEAR 3RD G.	1
10*	79433018000	SHIFT COLLAR	1
11	59033080000	SHIM 20X32X1	1
12*	79433011000	IDLER GEAR 1ST G.	1
13	0405202612	NEEDLE BEARING K 20X26X12	1
14	56033030000	STOP DISC 17,2X30X1	1
15	49030023000	CYL.ROLL BEARING NJ205	1
16	0760324571	SHAFT SEAL RING 32X45X7 BSLNBR	1
17	0770020220	O-RING 25,12X1,78 NBR70	1
18	78133014000	SPACER SLEEVE COUNTER	1
19*	79233029013	SPROCKET 13T	1
19*	79233029014	SPROCKET 14T	X
20	59033034044	SCREW 10.9+SPRING WASHER	1
21	0019050121S	INT. TORX FLAT HEAD M5X12 T25	2
22	78033132000	TAB WASHER BEARING COUNT.SHAFT	1
23	0625062035	BALL BEARING 6203 JR2 C3	1
24	0471170015	CIRCLIP DIN 0471-17X1, 5	1

167943360

C167943360

* NEW PART X ON DEMAND

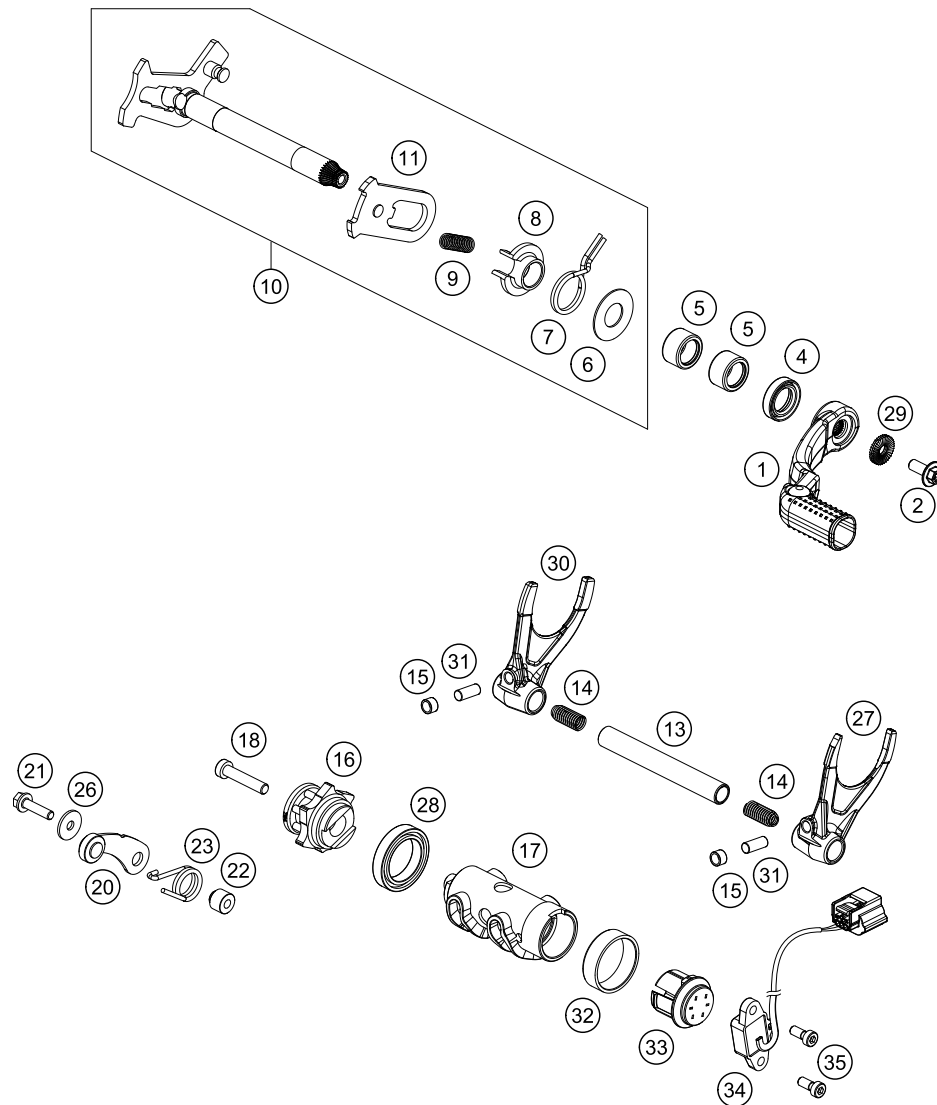

167943410

POS	PARTNUMBER	PARTNAME	PIECE
1*	79434031000	SHIFTING LEVER CPL.	1
2*	0024060156S	HH COLLAR SCREW M6X15 TORX30	1
4	0760142460	SHAFT SEAL RING 14X24X6 B	1
5	54632095000	NEEDLE BEAR.HK 1412 14X20X12	2
6	54634050000	STOP DISK 14X30X1	1
7	54634014100	RETURN SPRING 2,2MM '95	1
8	54634020000	SPRING GUIDE	1
9	56534013100	TENSIONING SPRING 0,8MM	1
10*	79434005133	SHIFT SHAFT CPL.	1
11*	54634108044	SLIDING PLATE	1
13*	79434020000	GEAR SHIFT RAIL 11,8X91,1MM	1
14	58038023200	PRESSURE SPRING 0,9MM	2
15	50334018100	SHIFTING ROLLER 6X8X5,2	2
16*	79434015000	SELECTOR INTERLOCK MECHAN. CPL	1
17*	79434012100	SHIFTROLLER 4-GEAR	1
18	0012060303	% AH SCREW DIN6912 M6X30 8.8	1
20	78134024044	LOCKING LEVER CPL.	1
21	0025050206	HH COLLAR SCREW M5X20 TX30	1
22	54634052300	SLEEVE FOR LOCKING LEVER	1
23	60034023000	ARRESTING LEVER SPRING 03	1
26	0021050003	WASHER DIN9021-A 5,3	1
27*	79434002100	SHIFTING FORK 2ND-4TH GEAR	1
28	0625618050	BALL BEARING 61805 C3	1
29	50233041500	NORDLOCK WASHER M6	1
30*	79434003100	SHIFTING FORK 1ST-3RD GEAR	1
31*	0402061480	NEEDLE ROLLER DIN5402 6X14,8	2
32*	79234012010	FRICTION BEARING CONTROLLER	1
33*	79234012020	MAGNET HOLDER CPL.	1
34*	79211023000	GEAR SENSOR	1
35*	0984050123S	CYLIND. SCR. DIN6912 M5X12 8.8	2

C167943411

* NEW PART

X ON DEMAND

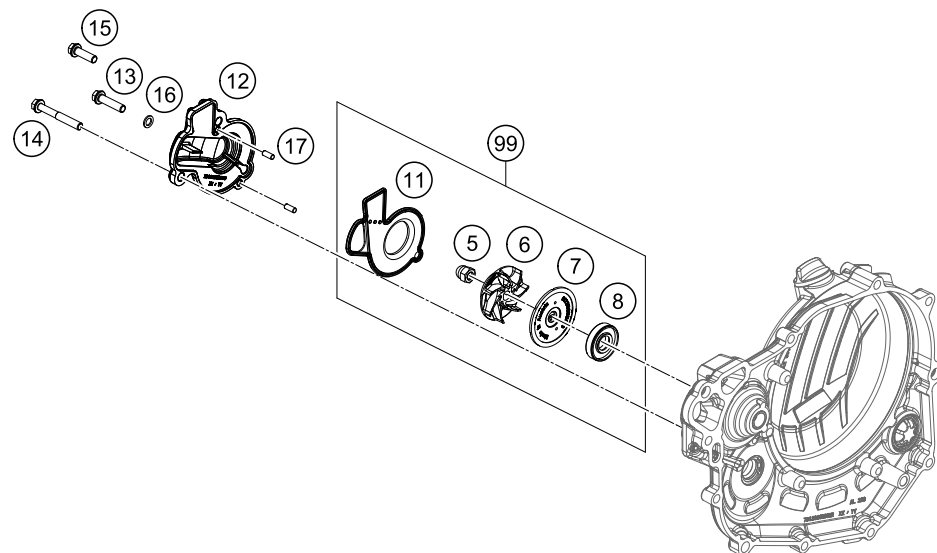

POS	PARTNUMBER	PARTNAME	PIECE
5	61230045000	CAP NUT M6 STAINLESS STEEL	1
6	81235055020	WATER PUMP ROTOR	1
7	81235055110	DISC WATER PUMP	1
8	0760123073	SHAFT SEAL RING 12X30X7 PTFE	1
11*	79435053000	SEAL WITH CARRIER PLATE	1
12*	79435052000	WATER PUMP COVER	1
13	0025060256	HH COLLAR SCREW M6X25 TX30	1
14*	0025060456	HH COLLAR SCREW M6X45 TX30	1
15*	0025060206	HH COLLAR SCREW M6X20 TX30	1
16	0603061001	CU-SEAL RING DIN7603-6X10X1	1
17*	0402040980	NEEDLE ROL.DIN5402 NRB 4X9,8	2
99	79435055015	WATER PUMP REP. KIT	x

157893510

C157893510

* NEW PART

X ON DEMAND

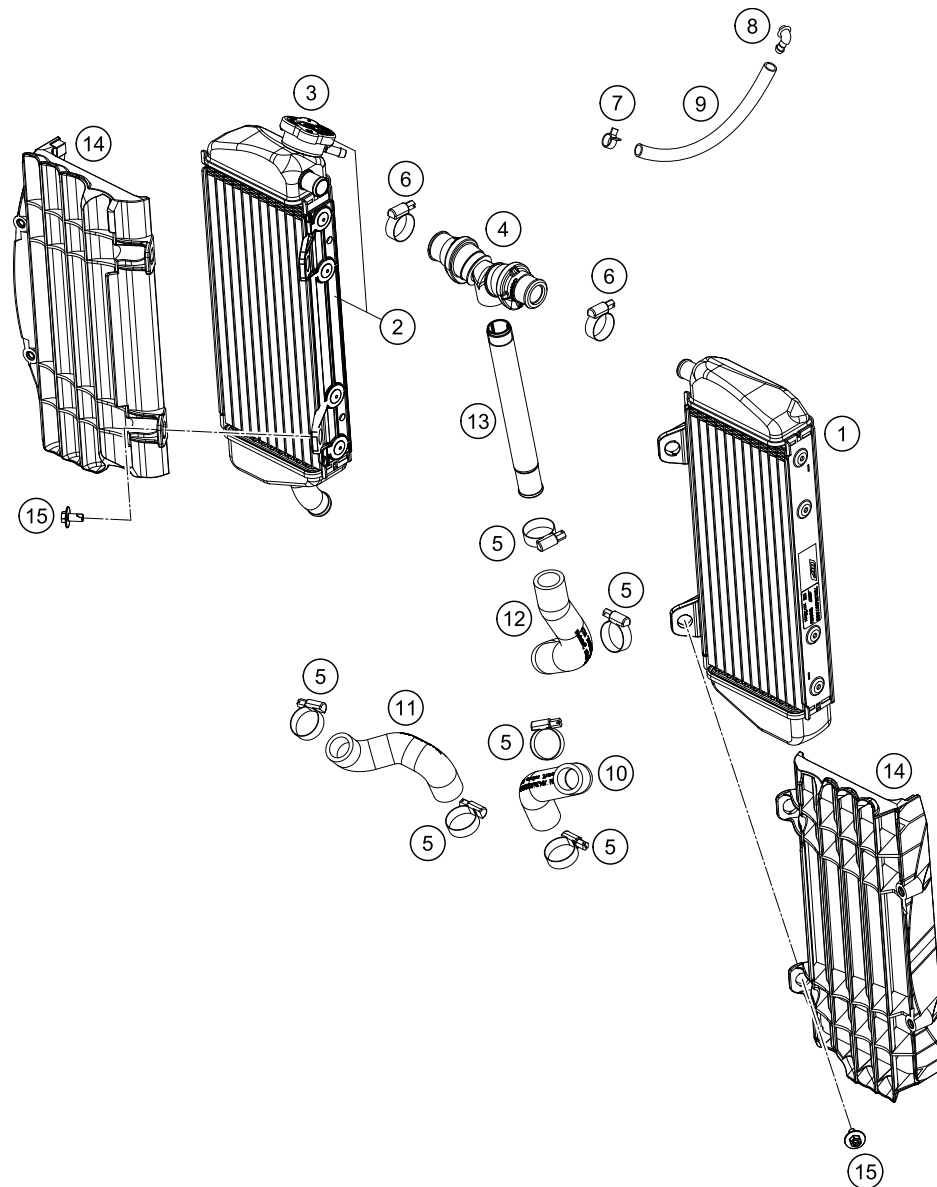

POS	PARTNUMBER	PARTNAME	PIECE
1*	50435007000	RADIATOR LEFT 16	1
2*	79635008000	RADIATOR RIGHT	1
3*	79035016000	RADIATOR CAP 1,8 BAR	1
4*	79035071044	Y-PIECE CPL.	1
5	10001020000	HOSE CLAMP GEMI 18-29	6
6	42013037400	HOSE CLAMP NORMA 14/24	2
7	59007017000	CLAMP YDNAC 10096F (9,6MM)	1
8	50303089000	ANGLE PIECE '97	1
9	50335030001	PVC-HOSE 6X9	x
10*	79435025100	RADIATOR HOSE LEFT	1
11*	79435027100	RADIATOR HOSE RIGHT	1
12*	79435024000	RADIATOR HOSE	1
13	77235073000	HOSE CONNECTOR L=172,5	1
14*	7903503400030	RADIATOR PROTECT 2016	2
15*	0024060123	COLLAR SCREW M6X12 TX	4

157893531

C167943530

* NEW PART

X ON DEMAND

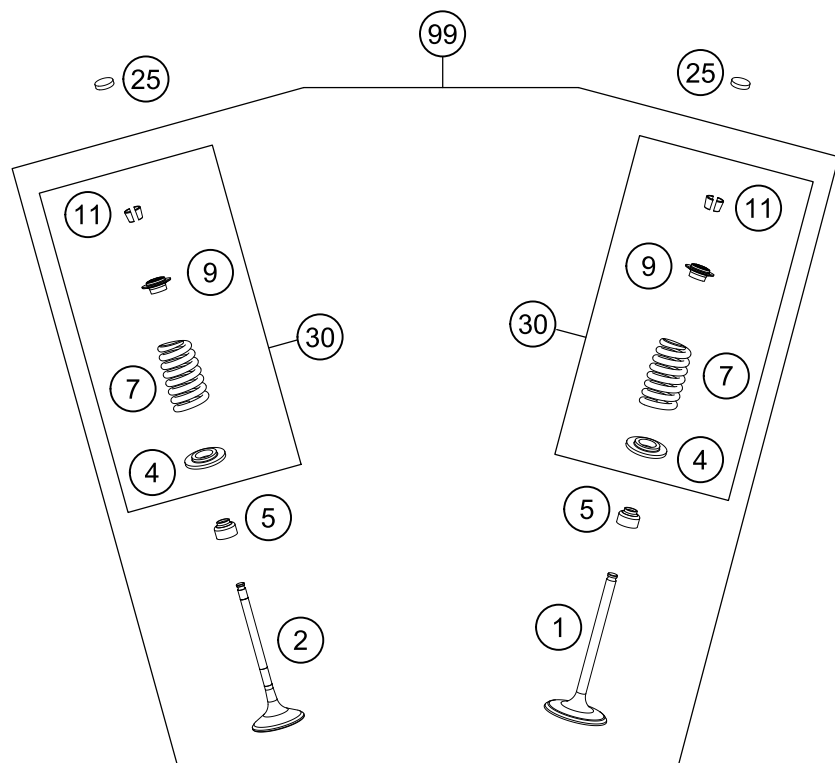
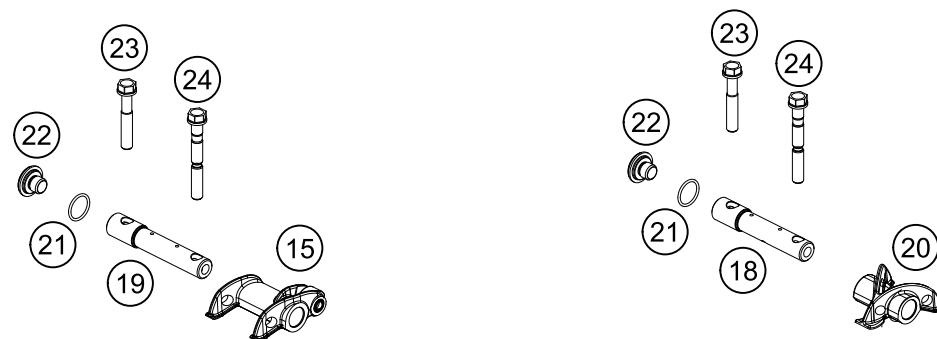

AUSLASS / EXHAUST

EINLASS / INTAKE

POS	PARTNUMBER	PARTNAME	PIECE
1	78936030100	INTAKE VALVE	2
2	78936031000	EXHAUST VALVE	2
4	78936036000	VALVE SPRING HOLDER	4
5	59036027000	VALVE-STEM SEALING RACING	4
7	78936028000	VALVE SPRING	4
9*	78936032100	VALVE SPRING RETAINER	4
11	77336033100	VALVE COLLET 07	8
15	78936061144	ROCKER ARM EXHAUST CPL.	1
18*	79436056100	ROCKER ARM SHAFT INTAKE	1
19*	79436057000	ROCKER ARM SHAFT EXHAUST	1
20	78936060000	% ROCKER ARM INTAKE	1
21	0770150151	O-RING 15,00X1,50 VITON	2
22*	79436081000	PLUG M10X1,25	2
23	77036080000	SPECIAL SCREW M7X40 WS10	2
24	78036080000	FIT BOLT M7X1X55	2
25	77036035172	SHIM D=8,9/1,72	x
25	77036035176	SHIM D=8,9/1,76	x
25	77036035180	SHIM D=8,9/1,80	x
25	77036035184	SHIM D=8,9/1,84	x
25	77036035188	SHIM D=8,9/1,88	x
25	77036035192	SHIM D=8,9/1,92	x
25	77036035196	SHIM D=8,9/1,96	x
25	77036035200	SHIM D=8,9/2,00	x
25	77036035204	SHIM D=8,9/2,04	x
25	77036035208	SHIM D=8,9/2,08	x
25	77036035212	SHIM D=8,9/2,12	x
25	77036035216	SHIM D=8,9/2,16	x
25	77036035220	SHIM D=8,9/2,20	x
25	77036035224	SHIM D=8,9/2,24	x
25	77036035228	SHIM D=8,9/2,28	x
25	77036035232	SHIM D=8,9/2,32	x
25	77036035236	SHIM D=8,9/2,36	x
25	77036035240	SHIM D=8,9/2,40	x
25	77036035244	SHIM D=8,9/2,44	x
25	77036035248	SHIM D=8,9/2,48	x
25	77036035252	SHIM D=8,9/2,52	x
25	77036035256	SHIM D=8,9/2,56	x
25	77036035260	SHIM D=8,9/2,60	x

157893610

C167943610

* NEW PART

X ON DEMAND

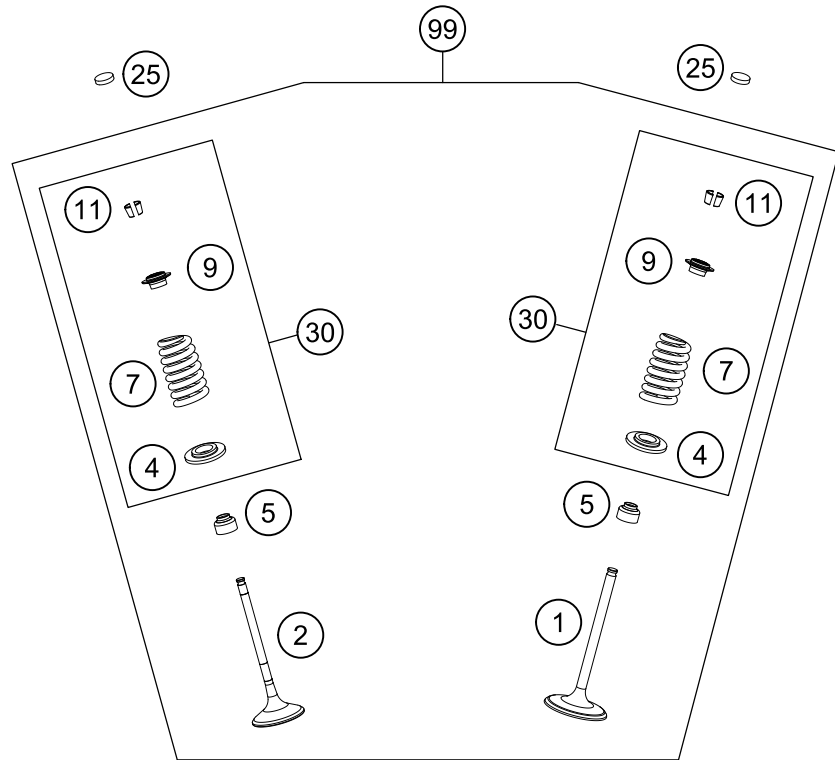
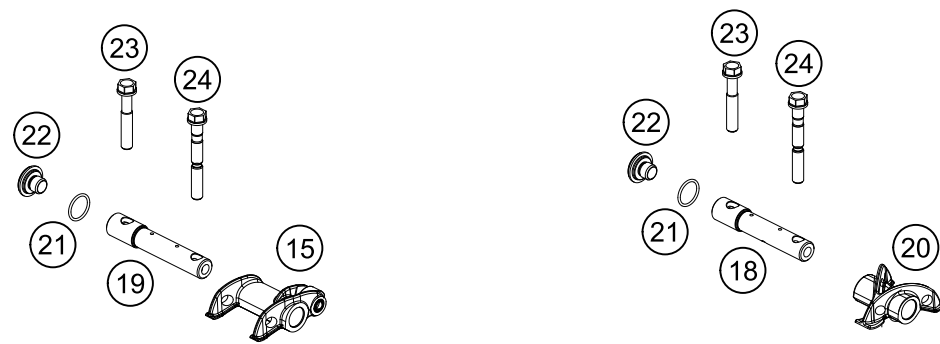

AUSLASS / EXHAUST

EINLASS / INTAKE

POS	PARTNUMBER	PARTNAME	PIECE
30	78936029144	VALVE SPRING KIT 450 SX-F 16	X
99	78936030110	VALVE KIT 450 HQV 14	X

157893610

C167943610

* NEW PART

X ON DEMAND

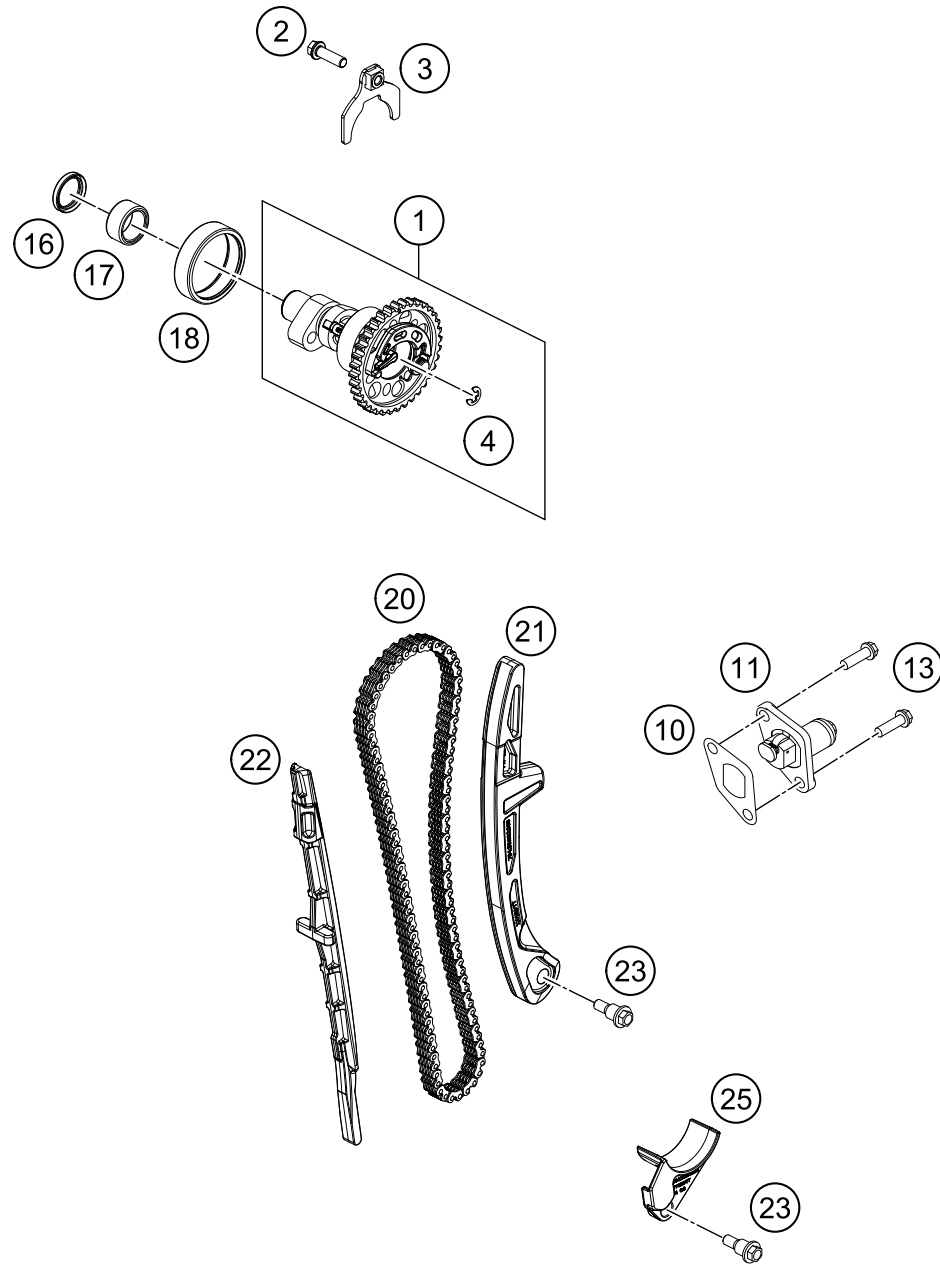

POS	PARTNUMBER	PARTNAME	PIECE
1*	79436010044	CAMSHAFT CPL. WITH DECO	1
2	0025060206S	HH COLLAR SCREW M6X20 TX30	1
3*	79436012033	BRACKET CAM SHAFT	1
4	0799050000	TAB WASHER DIN6799 RS5	1
10	59036003050	GASKET TIMING CHAIN TENSIONER	1
11	59036003000	TIMINGCHAIN TENSIONER CPL.RAC.	1
13	0025060166	HH COLLAR SCREW M6X16 TX30	2
16*	0760182442	SHAFT SEAL RING 18X24X4	1
17	0618182412	NEEDLE BEAR.HK1812 18/24/12 05	1
18	0618404712	NEEDLE SLEEVE HK4012B40X47X12	1
20*	77036013100	TIMING CHAIN 108 ROLLS	1
21*	79436002000	DRIVE CHAIN TENSIONING RAIL	1
22*	79436001000	DRIVE CHAIN GUIDE	1
23	77236001160	BUSHING SCREW M6	2
25*	79436018000	FAIL SAFE	1

157893620

C157893621

* NEW PART

X ON DEMAND

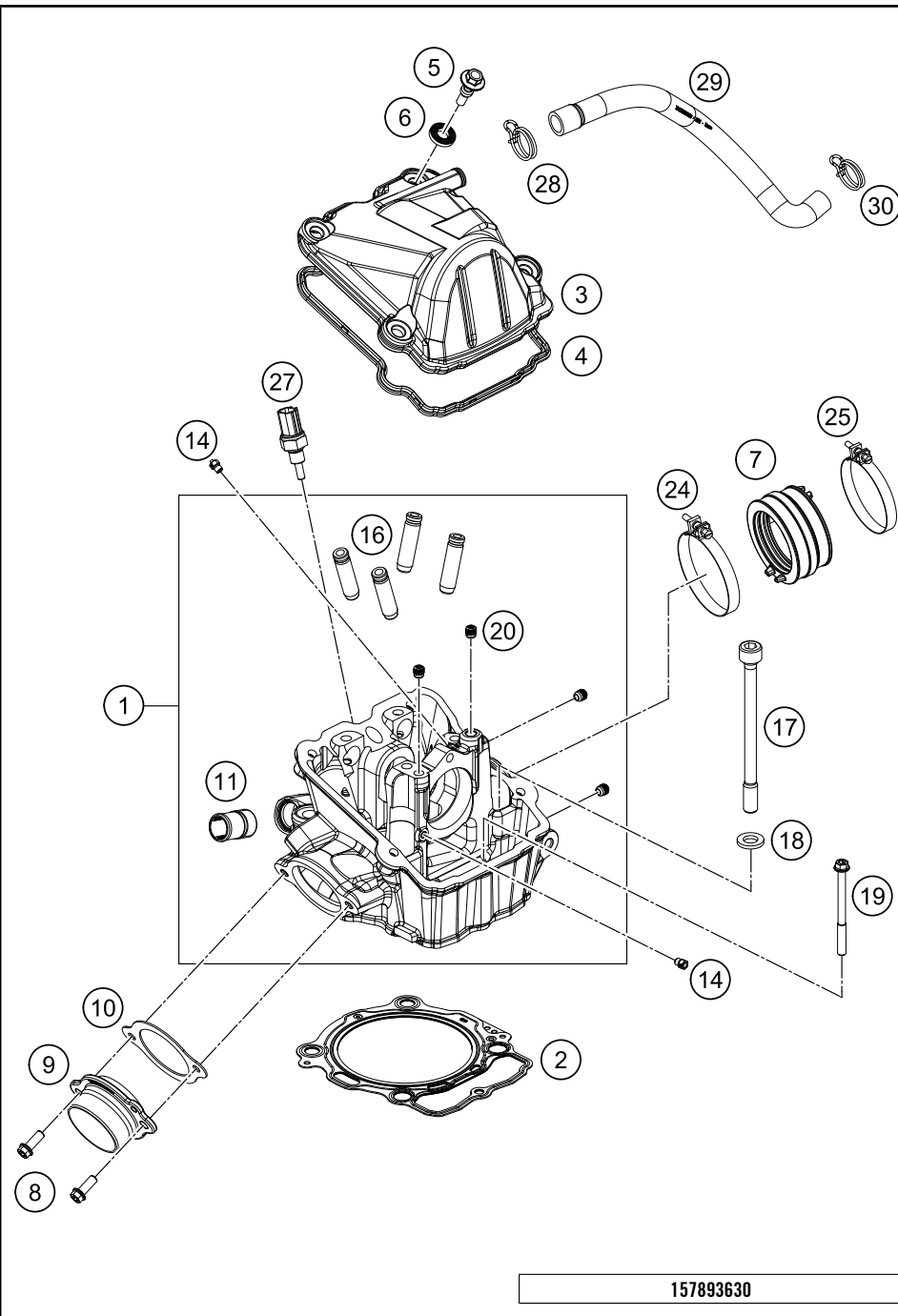

POS	PARTNUMBER	PARTNAME	PIECE
1*	79436020044	CYLINDER HEAD CPL.	1
2*	79430036010	CYLINDER HEAD GASKET (DN95)	1
3*	7943605200033	VALVE COVER	1
4*	79436053000	VALVE COVER GASKET	1
5	78036054100	VALVE COVER SCREW	4
6	75036052010	DECOUPLING ELEMENT 07	4
7*	79236044100	RUBBER CUP	1
8	0025060166S	HH COLLAR SCREW M6X16 ISA 30	2
9	78136139000	EXHAUST FLANGE	1
10	78036041000	EXHAUST FLANGE GASKET	1
11	58030010200	SCREW IN NOZZLE M20X1,5	1
14	60030063070	OIL JET 70 M5	2
16	78136025001	VALVE GUIDE INTAKE	4
17	78030044000	CYL. HEAD SCREW M10X1,25 L=125	4
18	77336089010	WASHER 19X10,5X2,5	4
19	0025060706	HH COLLAR SCREW M6X70 TX30	1
20	59030296000	SCREW PLUG	4
24	61036047000	HOSE CLAMP GEMI 63MM 05	1
25	77236048000	HOSE CLAMP GEMI 58MM	1
27*	79435047000	TEMPERATUR SENSOR WATER	1
28*	60306082000	CLAMP YDNAC 10173 (19MM)	1
29*	79430087000	ENGINE BREATHING HOSE	1
30	58431082100	YDNAC-CLAMP 10173 (16MM) '98	1

157893630

C157893631

* NEW PART

X ON DEMAND

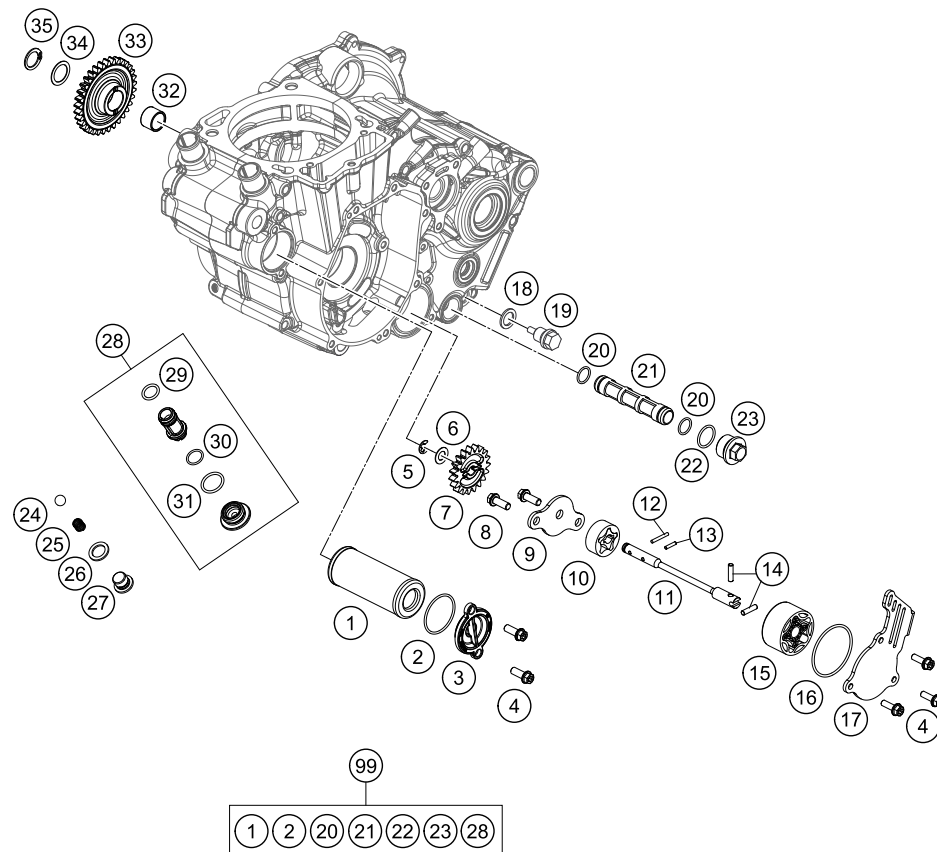

POS	PARTNUMBER	PARTNAME	PIECE
1*	77338005100	OIL FILTER	1
2*	07703305178	O-RING 33,05X1,78	1
3*	77338041200	OIL FILTER COVER 08	1
4	0025050166	HH COLLAR SCREW M5X16 TX30	5
5	0799060000	TAB WASHER DIN6799-RS 6,0	1
6	58038007755	STOP DISK 8,1 X 15 X 0,5	1
7*	79438001019	OIL PUMP SPROCKET 19T	1
8	0025060166S	HH COLLAR SCREW M6X16 ISA 30	2
9*	79438003000	OIL PUMP COVER	1
10*	59038011112	OILPUMP ROTOR-SET 12MM CPL.	1
11*	79438002000	OIL PUMP SHAFT	1
12	0402251980	NEEDLEROL.DIN5402 NRA 2,5X19,8	1
13	0402251180	NEEDLE ROLLER DIN5402 2,5X11,8	1
14	0402041580	NEEDLE ROLLER NRB 4X15,8 G2	2
15	61238011100	ROTOR SET 22MM	1
16	0770440020	O-RING 44,00X2,00 VITON	1
17*	79438004100	OIL PUMP COVER	1
18	58038022000	CU-SEAL RING DIN7603-12X18X1,5	1
19	58030021000	OILDRAIN PLUG W.MAG. M 12X1,5	1
20	07701250151	O-RING 12,5X1,5 VITON V75	2
21	59038016100	OIL SCREEN	1
22	0770020170	O-RING 17,17X1,78 GLO	1
23*	59038017100	PLUG M20X1,5 WS=13	1
24	0401090003	BALL DIN5401-9	1
25*	79438026000	PRESSURE SPRING	1
26	58038022000	CU-SEAL RING DIN7603-12X18X1,5	1
27	78036024000	PLUG SCREW SAS M12X1,5	1
28	78138015001	OIL SCREEN CPL.	1
29	0770012021	O-RING 12X2 VITON GREEN	1
30	0770125015	O-RING 12,5X1,5 NBR	1
31	0770170200	O-RING 17,00X2,00	1
32*	79438001010	NEEDLE BEARING INNER RING	1
33*	79438001033	IDLER WHEEL 33T	1
34*	0988162205	THRUST WASH. DIN0988-16X22X0,5	1
35*	0471150010	CIRCLIP DIN0471-15X1	1
99	79438015010	OILFILTER SERVICEKIT SX-F	x

157893810

C167943810

* NEW PART

X ON DEMAND

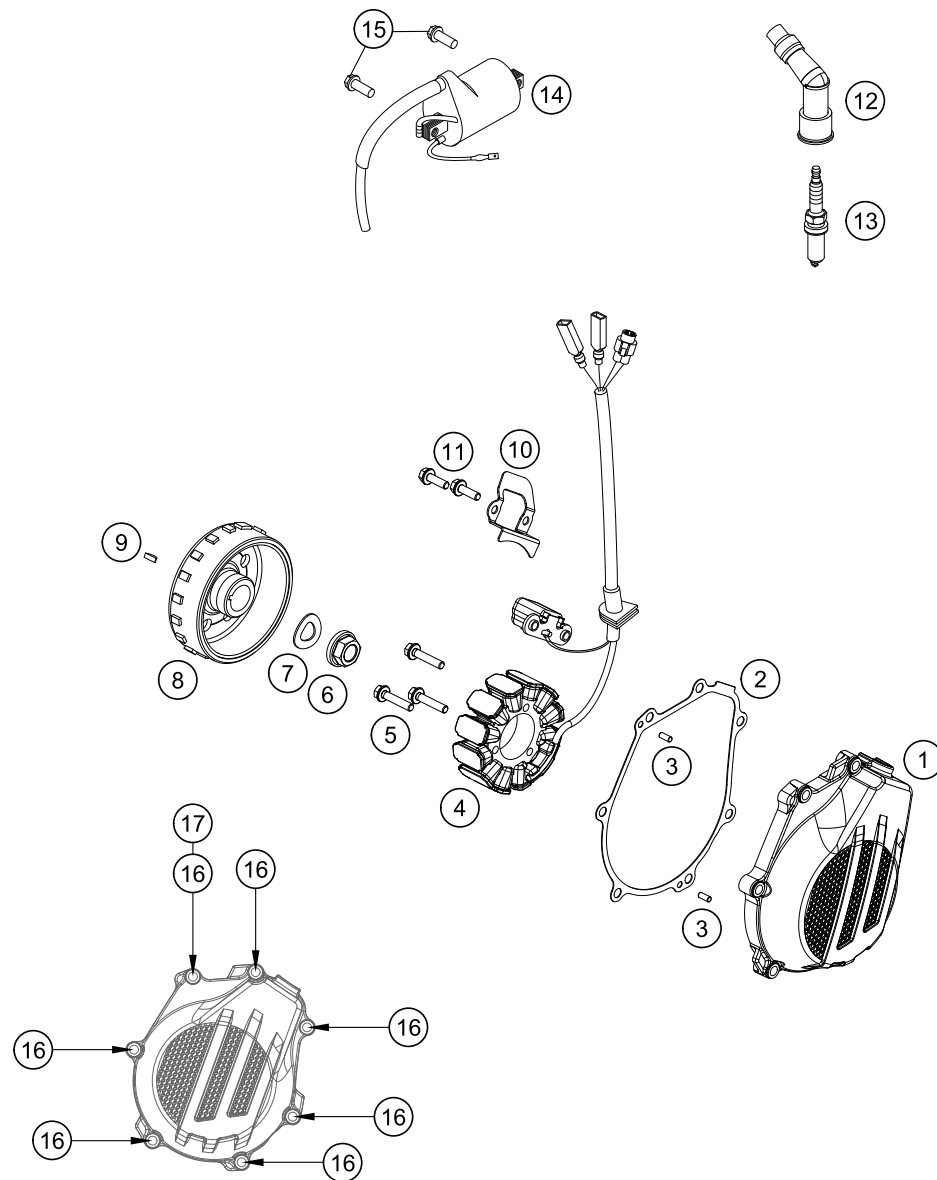

POS	PARTNUMBER	PARTNAME	PIECE
1*	7943000200015	IGNITION COVER 450	1
2*	79430040000	IGNITION COVER GASKET	1
3	0402040980	NEEDLE ROL.DIN5402 NRB 4X9,8	2
4*	79239004000	STATOR	1
5*	0025050256	HH COLLAR SCREW M5X25 ISA30	3
6	49030021000	COLLAR NUT M12X1 R/S	1
7	0137120000	SPRING WASHER DIN0137-B12	1
8*	79439005000	ROTOR	1
9	0888030050	WOODRUFF KEY DIN6888-3X5X13	1
10*	79430002050	CABLE HOLDER PLATE	1
11*	0025050166	HH COLLAR SCREW M5X16 TX30	2
12	78039090100	SPARK PLUG CONNECTOR	1
13*	77239093000	PLUG NGK LMAR9AI - 8	1
14	58439006000	IGNITIONCOIL IG3826 KOKUSAN'96	1
15	0026060186	COLLAR SCREW M6X18 ISA30	2
16	0025060256	HH COLLAR SCREW M6X25 TX30	7
17*	0603061001	CU-SEAL RING DIN7603-6X10X1	1

157893910

C157893911

* NEW PART

X ON DEMAND

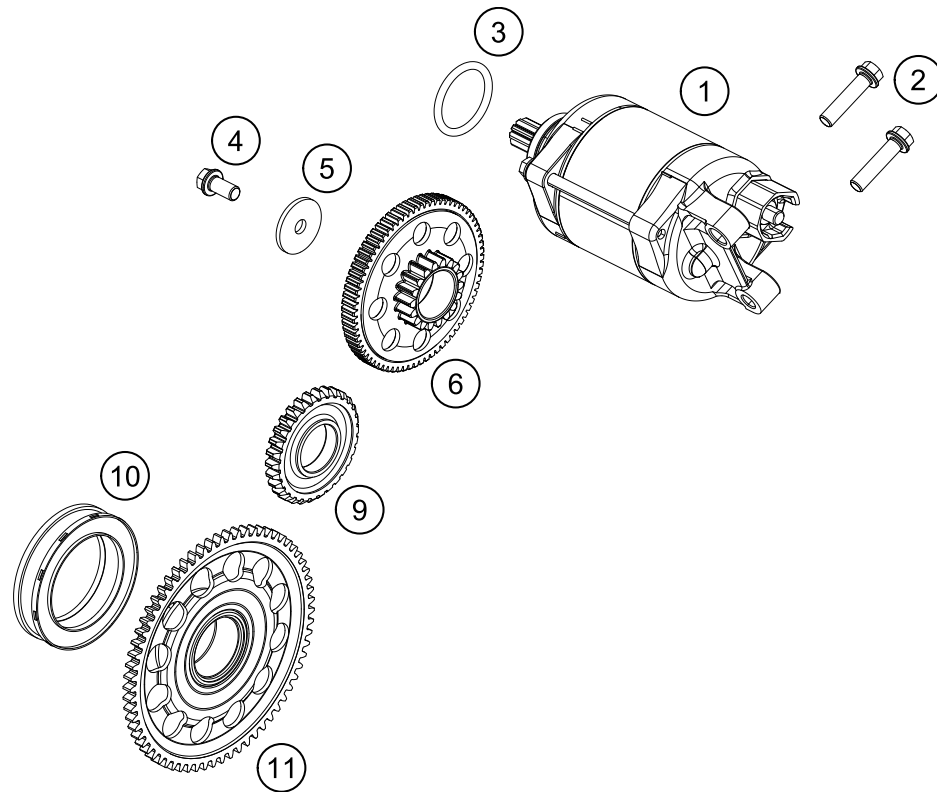

POS	PARTNUMBER	PARTNAME	PIECE
1*	79440001000	E-STARTER CPL. 0,5KW	1
2	0025060256	HH COLLAR SCREW M6X25 TX30	2
3	0770250030	O-RING 25,00X3,00 NBR 70	1
4*	0025060126	HH COLLAR SCREW M6X12 TX30	1
5	78040016004	STOP DISC 6X23X2	1
6*	79440016000	TORQUE LIMITER CPL.	1
9*	79440022030	IDLER WHEEL 30T	1
10	75040026000	FREE WHEEL	1
11*	79440020033	FREEWHEEL SPROCKET CPL.	1

157894010

C157894010

* NEW PART

X ON DEMAND

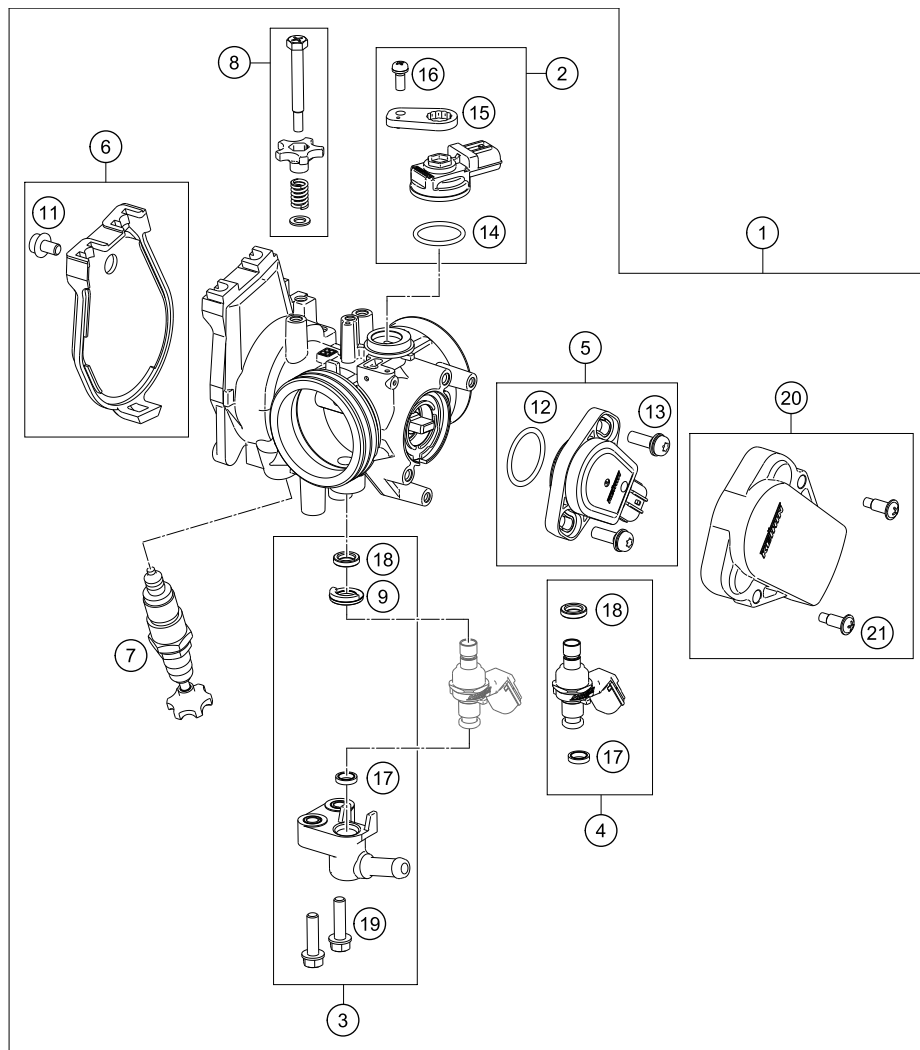

POS	PARTNUMBER	PARTNAME	PIECE
1*	79041001000	THROTTLE BODY	1
2*	77741085044	MAP SENSOR CPL.	1
3*	79041013044	FUEL PIPE CPL.	1
4*	79041023044	INJECTOR CPL.	1
5*	79041077044	TPS CPL.	1
6*	79041056044	THROTTLE COVER CPL.	1
7*	79041070000	STARTER VALVE CPL.	1
8	77741060044	IDLING ADJUSTING SCREW CPL.	1
9*	79041023030	SEAL RING	1
11*	79041056020	SPECIAL SCREW	1
12*	75041077110	O-RING	1
13*	61041077020	SCREW THROTTLE POS. SENSOR	2
14	75041085010	O-RING	1
15	77741085020	PLATE	1
16	81241085030	SPECIAL SCREW	1
17*	60341023020	O-RING	1
18	75041023010	SEAL RING	1
19*	79041013060	SPECIAL SCREW M5X20	2
20*	79041078044	TPS COVER CPL.	1
21*	60031028000	SCREW KEIHIN 03	2
22	61041080000	AMBIENT-AIR TEMPERATURE SENSOR	1
23	0081645121	EJOT DELTA PT SCREW 45X12-Z	2
24	61041088000	ROLLOVER SENSOR 05	1
25	0025060206	HH COLLAR SCREW M6X20 TX30	2
27*	79041031000	ENGINE CONTROL UNIT EFI	1
28*	79041031050	ECU RUBBER HOLDER	1

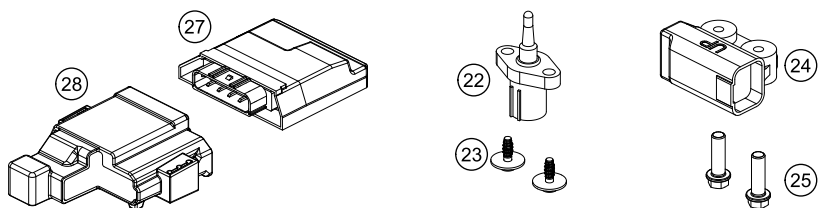

157894110

C157894111

* NEW PART X ON DEMAND

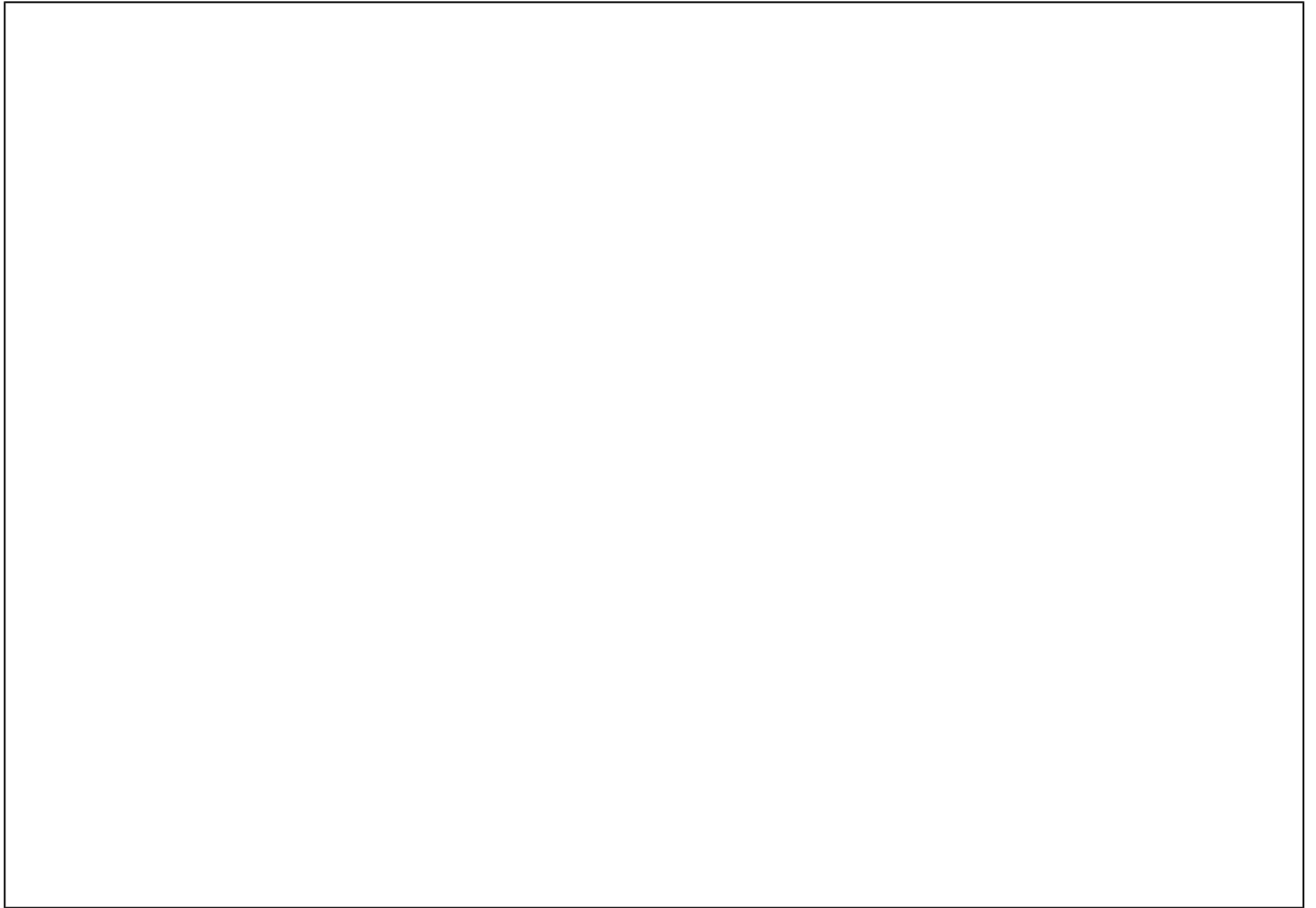

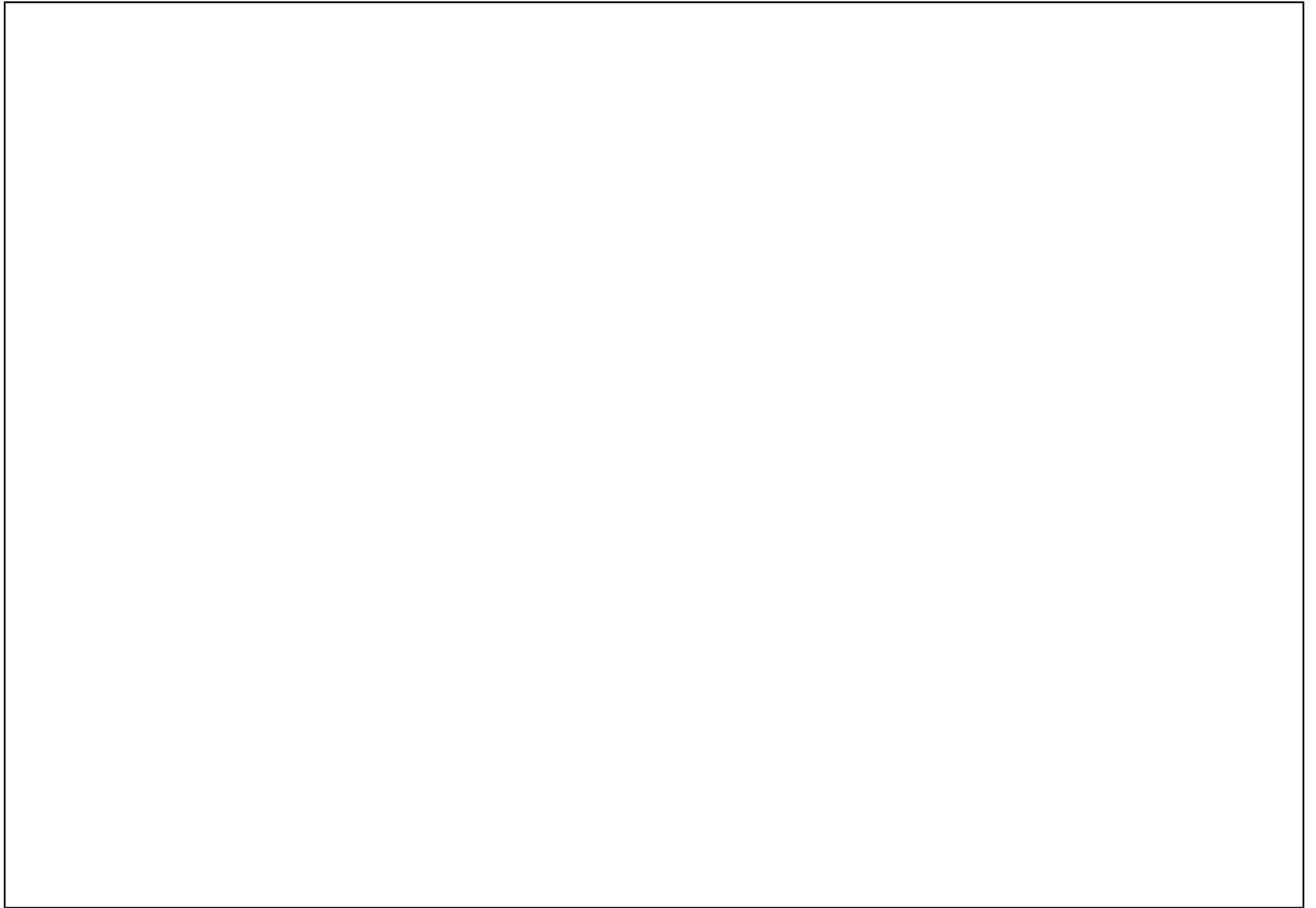



WWW.KTM.COM



KTM Sportmotorcycle GmbH
5230 Mattighofen, Austria
www.ktm.com



KTM_POWERPARTS

KTM_POWERWEAR

KTM_ORIGINAL SPARE PARTS



3CM089570PEN

Art. Nr.: 3CM089570PEN 9. Sep 2015