

250 EXC-F EU
250 EXC-F SIX DAYS EU
250 EXC-F AUS
250 XCF-W USA

Art. no. 3213035en



KTM

DEAR KTM CUSTOMER

Congratulations on your decision to purchase a KTM motorcycle. You are now the owner of a state-of-the-art sports motorcycle that will give you enormous pleasure if you service and maintain it accordingly.

We wish you a lot of enjoyment in riding this vehicle.

Please enter the serial number of your vehicle below.

| | |
|---|-----------------|
| Chassis number (☛ p. 12) | Stamp of dealer |
| Engine number (☛ p. 12) | |
| Key number (All EXC-F models) (☛ p. 12) | |

The Owner's Manual contained the latest information for this model series at the time of going to print. Slight deviations resulting from continuing development and design of the motorcycles can, however, not be completely excluded.

All specifications are non-binding. KTM Sportmotorcycle AG specifically reserves the right to modify or delete technical specifications, prices, colors, forms, materials, services, designs, equipment, etc., without prior notice and without specifying reasons, to adapt these to local conditions, as well as to stop production of a particular model without prior notice. KTM accepts no liability for delivery options, deviations from illustrations and descriptions, as well as misprints and other errors. The models portrayed partly contain special equipment that does not belong to the regular scope of supply.

© 2013 KTM-Sportmotorcycle AG, Mattighofen Austria

All rights reserved

Reproduction, even in part, as well as copying of all kinds, is permitted only with the express written permission of the copyright owner.



ISO 9001(12 100 6061)

According to the international quality management standard ISO 9001, KTM uses quality assurance processes that lead to the maximum possible quality of the products.



































Issued by: TÜV Management Service











REG.NO. 12 100 6061

KTM-Sportmotorcycle AG
5230 Mattighofen, Austria

TABLE OF CONTENTS





| | | | | | |
|-------|--|----|--------|---|----|
| 1 | MEANS OF REPRESENTATION | 5 | 7.1.2 | Activation and test | 21 |
| 1.1 | Symbols used | 5 | 7.1.3 | Setting kilometers or miles | 21 |
| 1.2 | Formats used | 5 | 7.1.4 | Adjusting the speedometer functions | 22 |
| 2 | SAFETY ADVICE | 6 | 7.1.5 | Setting the clock | 22 |
| 2.1 | Use definition - intended use | 6 | 7.1.6 | Querying lap time | 22 |
| 2.2 | Safety advice | 6 | 7.1.7 | Display mode SPEED (speed) | 23 |
| 2.3 | Degrees of risk and symbols | 6 | 7.1.8 | Display mode SPEED/H (service hours) | 23 |
| 2.4 | Tampering warning | 6 | 7.1.9 | Setup menu | 23 |
| 2.5 | Safe operation | 7 | 7.1.10 | Unit of measurement menu | 24 |
| 2.6 | Protective clothing | 7 | 7.1.11 | Display mode SPEED/CLK (time) | 24 |
| 2.7 | Work rules | 7 | 7.1.12 | Setting the clock | 24 |
| 2.8 | Environment | 7 | 7.1.13 | Display mode SPEED/LAP (lap time) | 25 |
| 2.9 | Owner's Manual | 8 | 7.1.14 | Viewing the lap time | 25 |
| 3 | IMPORTANT NOTES | 9 | 7.1.15 | Display mode SPEED/ODO (odometer) | 25 |
| 3.1 | Guarantee, warranty | 9 | 7.1.16 | Display mode SPEED/TR1 (trip master 1) | 25 |
| 3.2 | Operating and auxiliary substances | 9 | 7.1.17 | Display mode SPEED/TR2 (trip master 2) | 26 |
| 3.3 | Spare parts, accessories | 9 | 7.1.18 | Setting TR2 (trip master 2) | 26 |
| 3.4 | Service | 9 | 7.1.19 | Display mode SPEED/A1 (average speed 1) | 26 |
| 3.5 | Figures | 9 | 7.1.20 | Display mode SPEED/A2 (average speed 2) | 27 |
| 3.6 | Customer service | 9 | 7.1.21 | Display mode SPEED/S1 (stop watch 1) | 27 |
| 4 | VIEW OF VEHICLE | 10 | 7.1.22 | Display mode SPEED/S2 (stop watch 2) | 27 |
| 4.1 | View of vehicle, front left (example) | 10 | 7.1.23 | Table of functions | 27 |
| 4.2 | View of vehicle, rear right (example) | 11 | 7.1.24 | Table of conditions and menu activation | 28 |
| 5 | SERIAL NUMBERS | 12 | 7.2 | EXC-F SIX DAYS | 28 |
| 5.1 | Chassis number | 12 | 7.2.1 | Speedometer overview | 28 |
| 5.2 | Type label | 12 | 7.2.2 | Activation and test | 29 |
| 5.3 | Key number (All EXC-F models) | 12 | 7.2.3 | Setting kilometers or miles | 29 |
| 5.4 | Engine number | 12 | 7.2.4 | Setting the speedometer functions | 29 |
| 5.5 | Fork part number | 12 | 7.2.5 | Setting the clock | 30 |
| 5.6 | Shock absorber part number | 13 | 7.2.6 | Viewing the lap time | 30 |
| 6 | CONTROLS | 14 | 7.2.7 | Display mode SPEED (speed) | 31 |
| 6.1 | Clutch lever | 14 | 7.2.8 | Display mode SPEED/H (service hours) | 31 |
| 6.2 | Hand brake lever | 14 | 7.2.9 | Setup menu | 31 |
| 6.3 | Throttle grip | 14 | 7.2.10 | Setting the unit of measurement | 32 |
| 6.4 | Kill switch (All EXC-F models) | 14 | 7.2.11 | Display mode SPEED/CLK (time) | 32 |
| 6.5 | Kill switch (XCF-W) | 14 | 7.2.12 | Setting the clock | 32 |
| 6.6 | Horn button (All EXC-F models) | 15 | 7.2.13 | Display mode SPEED/LAP (lap time) | 33 |
| 6.7 | Light switch (All EXC-F models) | 15 | 7.2.14 | Viewing the lap time | 33 |
| 6.8 | Light switch (XCF-W) | 15 | 7.2.15 | Display mode SPEED/ODO (odometer) | 33 |
| 6.9 | Turn signal switch (All EXC-F models) | 15 | 7.2.16 | Display mode SPEED/TR1 (trip master 1) | 33 |
| 6.10 | Emergency OFF switch (EXC-F AUS) | 15 | 7.2.17 | Display mode SPEED/TR2 (trip master 2) | 34 |
| 6.11 | Electric starter button (EXC-F EU, EXC-F SIX DAYS, XCF-W) | 16 | 7.2.18 | Setting TR2 (trip master 2) | 34 |
| 6.12 | Electric starter button (EXC-F AUS) | 16 | 7.2.19 | Display mode SPEED/A1 (average speed 1) | 34 |
| 6.13 | Overview of indicator lamps (EXC-F EU, EXC-F AUS) | 16 | 7.2.20 | Display mode SPEED/A2 (average speed 2) | 35 |
| 6.14 | Overview of indicator lamps (EXC-F SIX DAYS) | 16 | 7.2.21 | Display mode SPEED/S1 (stop watch 1) | 35 |
| 6.15 | Overview of indicator lamps (XCF-W) | 16 | 7.2.22 | Display mode SPEED/S2 (stop watch 2) | 35 |
| 6.16 | Opening filler cap | 17 | 7.2.23 | Table of functions | 36 |
| 6.17 | Closing filler cap | 17 | 7.2.24 | Table of conditions and menu activation | 37 |
| 6.18 | Idle speed adjusting screw | 18 | 8 | PREPARING FOR USE | 38 |
| 6.19 | Shift lever | 18 | 8.1 | Advice on first use | 38 |
| 6.20 | Kick starter | 18 | 8.2 | Running-in the engine | 39 |
| 6.21 | Foot brake lever | 19 | 8.3 | Preparing the vehicle for difficult riding conditions | 39 |
| 6.22 | Side stand | 19 | 8.4 | Preparing for rides on dry sand | 40 |
| 6.23 | Steering lock (All EXC-F models) | 19 | 8.5 | Preparing for rides on wet sand | 40 |
| 6.24 | Locking the steering (All EXC-F models) | 19 | 8.6 | Preparing for rides on wet and muddy surfaces | 41 |
| 6.25 | Unlocking the steering (All EXC-F models) | 20 | 8.7 | Preparing for rides at high temperature and slow speed | 41 |
| 7 | SPEEDOMETER | 21 | 8.8 | Preparing for rides at low temperature or in snow | 41 |
| 7.1 | EXC-F EU, EXC-F AUS, XCF-W | 21 | | | |
| 7.1.1 | Speedometer overview | 21 | | | |

| | | | | | |
|-------|---|----|-------|--|----|
| 9 | RIDING INSTRUCTIONS..... | 42 | 12.20 | Installing the front fender | 66 |
| 9.1 | Checks and maintenance work when preparing for use | 42 | 12.21 | Removing the shock absorber  | 67 |
| 9.2 | Starting..... | 42 | 12.22 | Installing the shock absorber  | 67 |
| 9.3 | Starting off..... | 43 | 12.23 | Removing the seat | 67 |
| 9.4 | Shifting, riding | 43 | 12.24 | Mounting the seat | 68 |
| 9.5 | Braking..... | 43 | 12.25 | Removing the air filter box lid | 68 |
| 9.6 | Stopping, parking..... | 44 | 12.26 | Installing the air filter box lid | 68 |
| 9.7 | Transport | 44 | 12.27 | Removing the air filter  | 68 |
| 9.8 | Refueling | 45 | 12.28 | Installing the air filter  | 69 |
| 10 | SERVICE SCHEDULE | 46 | 12.29 | Cleaning the air filter and air filter box  | 69 |
| 10.1 | Service schedule..... | 46 | 12.30 | Sealing the air filter box  | 70 |
| 10.2 | Service work (as additional order) | 47 | 12.31 | Removing main silencer..... | 70 |
| 11 | TUNING THE CHASSIS | 48 | 12.32 | Installing the main silencer..... | 70 |
| 11.1 | Checking the basic suspension setting against the rider's weight | 48 | 12.33 | Changing the glass fiber yarn filling of the main silencer  | 70 |
| 11.2 | Compression damping of shock absorber | 48 | 12.34 | Removing the fuel tank  | 71 |
| 11.3 | Adjusting the low-speed compression damping of the shock absorber | 48 | 12.35 | Installing the fuel tank  | 72 |
| 11.4 | Adjusting the high-speed compression damping of the shock absorber..... | 49 | 12.36 | Checking for chain dirt accumulation..... | 73 |
| 11.5 | Adjusting the rebound damping of the shock absorber..... | 49 | 12.37 | Cleaning the chain | 74 |
| 11.6 | Measuring rear wheel sag unloaded..... | 50 | 12.38 | Checking the chain tension..... | 74 |
| 11.7 | Checking the static sag of the shock absorber | 50 | 12.39 | Adjusting the chain tension..... | 75 |
| 11.8 | Checking the riding sag of the shock absorber.... | 50 | 12.40 | Checking the chain, rear sprocket, engine sprocket and chain guide..... | 75 |
| 11.9 | Adjusting the spring preload of the shock absorber  | 51 | 12.41 | Checking the frame  | 77 |
| 11.10 | Adjusting the riding sag  | 51 | 12.42 | Checking the swingarm  | 77 |
| 11.11 | Checking basic setting of fork | 52 | 12.43 | Checking the throttle cable routing | 77 |
| 11.12 | Adjusting the compression damping of the fork | 52 | 12.44 | Checking the rubber grip | 78 |
| 11.13 | Adjusting the rebound damping of the fork | 53 | 12.45 | Additionally securing the rubber grip..... | 78 |
| 11.14 | Adjusting the spring preload of the fork (EXC-F EU, EXC-F AUS, XCF-W)..... | 54 | 12.46 | Adjusting the basic position of the clutch lever | 78 |
| 11.15 | Handlebar position..... | 54 | 12.47 | Checking/correcting the fluid level of the hydraulic clutch..... | 79 |
| 11.16 | Adjusting handlebar position  | 54 | 12.48 | Changing the hydraulic clutch fluid  | 79 |
| 12 | SERVICE WORK ON THE CHASSIS..... | 56 | 12.49 | Removing the engine guard (EXC-F AUS, EXC-F SIX DAYS)..... | 80 |
| 12.1 | Raising the motorcycle with the lift stand..... | 56 | 12.50 | Installing the engine guard (EXC-F AUS, EXC-F SIX DAYS)..... | 80 |
| 12.2 | Removing the motorcycle from the lift stand..... | 56 | 13 | BRAKE SYSTEM | 81 |
| 12.3 | Bleeding fork legs | 56 | 13.1 | Checking free travel of hand brake lever | 81 |
| 12.4 | Cleaning the dust boots of the fork legs..... | 56 | 13.2 | Adjusting free travel of hand brake lever (All EXC-F models)..... | 81 |
| 12.5 | Loosening the fork protector..... | 57 | 13.3 | Adjusting the basic position of the hand brake lever (XCF-W) | 81 |
| 12.6 | Positioning the fork protector | 57 | 13.4 | Checking the brake discs | 82 |
| 12.7 | Removing the fork legs  | 57 | 13.5 | Checking the brake fluid level of the front brake | 82 |
| 12.8 | Installing the fork legs  | 58 | 13.6 | Adding front brake fluid  | 82 |
| 12.9 | Removing the fork protector  | 59 | 13.7 | Checking the front brake linings | 83 |
| 12.10 | Installing the fork protector  | 59 | 13.8 | Changing the front brake linings  | 84 |
| 12.11 | Removing the lower triple clamp (EXC-F EU, EXC-F AUS, XCF-W)..... | 59 | 13.9 | Checking the free travel of foot brake lever | 85 |
| 12.12 | Removing the lower triple clamp  (EXC-F SIX DAYS)..... | 60 | 13.10 | Adjusting the basic position of the foot brake lever  | 85 |
| 12.13 | Installing the lower triple clamp  (EXC-F EU, EXC-F AUS, XCF-W) | 61 | 13.11 | Checking the rear brake fluid level..... | 86 |
| 12.14 | Installing the lower triple clamp  (EXC-F SIX DAYS)..... | 63 | 13.12 | Adding rear brake fluid  | 86 |
| 12.15 | Checking the steering head bearing play..... | 64 | 13.13 | Checking the rear brake linings | 87 |
| 12.16 | Adjusting the play of the steering head bearing  (EXC-F EU, EXC-F AUS, XCF-W)..... | 65 | 13.14 | Changing the rear brake linings  | 88 |
| 12.17 | Adjusting the play of the steering head bearing  (EXC-F SIX DAYS)..... | 65 | 14 | WHEELS, TIRES | 90 |
| 12.18 | Greasing the steering head bearing  | 66 | 14.1 | Removing the front wheel  | 90 |
| 12.19 | Removing the front fender | 66 | 14.2 | Installing the front wheel  | 90 |
| | | | 14.3 | Removing the rear wheel  | 91 |
| | | | 14.4 | Installing the rear wheel  | 92 |
| | | | 14.5 | Checking the tire condition | 92 |

| | | | | |
|--------|---|-----|--------------------|-----|
| 14.6 | Checking the tire air pressure..... | 93 | 26 STANDARDS | 130 |
| 14.7 | Checking spoke tension | 93 | INDEX | 131 |
| 15 | ELECTRICAL SYSTEM | 95 | | |
| 15.1 | Removing the battery  | 95 | | |
| 15.2 | Installing the battery  | 95 | | |
| 15.3 | Charging the battery  | 96 | | |
| 15.4 | Changing the main fuse..... | 97 | | |
| 15.5 | Changing the fuses of individual power consumers..... | 98 | | |
| 15.6 | Removing headlight mask with headlight..... | 98 | | |
| 15.7 | Refitting the headlight mask with the headlight..... | 99 | | |
| 15.8 | Changing the headlight bulb | 99 | | |
| 15.9 | Checking the headlight setting | 100 | | |
| 15.10 | Adjusting the headlight range..... | 100 | | |
| 15.11 | Changing the turn signal bulb | 101 | | |
| 15.12 | Changing the speedometer battery | 101 | | |
| 16 | COOLING SYSTEM | 103 | | |
| 16.1 | Cooling system | 103 | | |
| 16.2 | Checking the antifreeze and coolant level | 103 | | |
| 16.3 | Checking the coolant level | 104 | | |
| 16.4 | Draining the coolant  | 104 | | |
| 16.5 | Refilling coolant  | 105 | | |
| 17 | TUNING THE ENGINE..... | 106 | | |
| 17.1 | Checking the play in the throttle cable..... | 106 | | |
| 17.2 | Adjusting the play in the throttle cable  | 106 | | |
| 17.3 | Adjusting the idle speed  | 107 | | |
| 17.4 | Checking the basic position of the shift lever ... | 107 | | |
| 17.5 | Adjusting the basic position of the shift lever  | 107 | | |
| 18 | SERVICE WORK ON THE ENGINE | 108 | | |
| 18.1 | Changing the fuel screen  | 108 | | |
| 18.2 | Checking the engine oil level..... | 108 | | |
| 18.3 | Changing the engine oil and oil filter, cleaning the oil screen  | 109 | | |
| 18.4 | Adding engine oil | 111 | | |
| 19 | CLEANING, CARE | 112 | | |
| 19.1 | Cleaning the motorcycle | 112 | | |
| 19.2 | Checks and maintenance steps for winter operation..... | 113 | | |
| 20 | STORAGE | 114 | | |
| 20.1 | Storage | 114 | | |
| 20.2 | Preparing for use after storage..... | 114 | | |
| 21 | TROUBLESHOOTING | 115 | | |
| 22 | BLINK CODE | 117 | | |
| 23 | TECHNICAL DATA..... | 119 | | |
| 23.1 | Engine | 119 | | |
| 23.2 | Engine tightening torques | 119 | | |
| 23.3 | Capacities | 121 | | |
| 23.3.1 | Engine oil | 121 | | |
| 23.3.2 | Coolant | 121 | | |
| 23.3.3 | Fuel | 121 | | |
| 23.4 | Chassis | 121 | | |
| 23.5 | Electrical system..... | 122 | | |
| 23.6 | Tires..... | 122 | | |
| 23.7 | Fork..... | 122 | | |
| 23.7.1 | EXC-F EU, EXC-F AUS, XCF-W | 122 | | |
| 23.7.2 | EXC-F SIX DAYS | 123 | | |
| 23.8 | Shock absorber..... | 123 | | |
| 23.9 | Chassis tightening torques | 124 | | |
| 24 | SUBSTANCES | 126 | | |
| 25 | AUXILIARY SUBSTANCES | 128 | | |

1.1 Symbols used

The meaning of specific symbols is described below.

-
- | | |
|--|---|
|  | Indicates an expected reaction (e.g. of a work step or a function). |
|  | Indicates an unexpected reaction (e.g. of a work step or a function). |
|  | All work marked with this symbol requires specialist knowledge and technical understanding. In the interest of your own safety, have these jobs performed by an authorized KTM workshop. There, your motorcycle will be optimally cared for by specially trained experts using the specialist tools required. |
|  | Indicates a page reference (more information is provided on the specified page). |
-

1.2 Formats used

The typographical formats used in this document are explained below.

-
- | | |
|--------------------------|--|
| Specific name | Identifies a proprietary name. |
| Name[®] | Identifies a protected name. |
| Brand[™] | Identifies a brand available on the open market. |
-

2.1 Use definition - intended use

(All EXC-F models)

KTM sport motorcycles are designed and built to withstand the normal stresses and strains of competitive use. The motorcycles comply with currently valid regulations and categories of the top international motorsport organizations.



Info

The vehicle should only be used by trained persons. The motorcycle is authorized for public road traffic in the homologous (reduced) version only.

In the derestricted version, the motorcycle must be used only on closed off property remote from public road traffic.

This motorcycle is designed for use in offroad endurance competition and not primarily for use in motocross.

(XCF-W)

KTM sport motorcycles are designed and built to withstand the normal stresses and strains of competitive use. The motorcycles comply with currently valid regulations and categories of the top international motorsport organizations.



Info

This motorcycle is designed for use in offroad endurance competition and not primarily for use in motocross.

2.2 Safety advice

A number of safety instructions need to be followed to operate the vehicle safely. Therefore, read this manual carefully. The safety instructions are highlighted in the text and are referred to at the relevant passages.



Info

The vehicle has various information and warning labels at prominent locations. Do not remove information/warning labels. If they are missing, you or others may not recognize dangers and may therefore be injured.

2.3 Degrees of risk and symbols



Danger

Identifies a danger that will immediately and invariably lead to fatal or serious permanent injury if the appropriate measures are not taken.



Warning

Identifies a danger that is likely to lead to fatal or serious injury if the appropriate measures are not taken.



Caution

Identifies a danger that may lead to minor injuries if the appropriate measures are not taken.

Note

Identifies a danger that will lead to considerable machine and material damage if the appropriate measures are not taken.



Warning

Identifies a danger that will lead to environmental damage if the appropriate measures are not taken.

2.4 Tampering warning



Tampering with the noise control system is prohibited. Federal law prohibits the following acts or the causing thereof:

- 1 The removal or rendering inoperative by any person other than for purposes of maintenance, repair, or replacement, of any device or element of design incorporated into any new vehicle for the purpose of noise control prior to its sale or delivery to the ultimate purchaser or while it is in use, or
- 2 the use of the vehicle after such device or element of design has been removed or rendered inoperative by any person.

Among those acts presumed to constitute tampering are the acts listed below:

- 1 Removal or puncturing of the main silencer, baffles, header pipes or any other components which conduct exhaust gases.
- 2 Removal or puncturing of parts of the intake system.
- 3 Lack of proper maintenance.
- 4 Replacing moving part of the vehicle, or parts of the exhaust or intake system, with parts other than those specified by the manufacturer.

2.5 Safe operation

-  **Danger**
Danger of accidents Danger arising from the rider's judgement being impaired.
- Do not operate the vehicle while under the influence of alcohol, drugs and certain medications or physically or mentally impaired.
-  **Danger**
Danger of poisoning Exhaust gases are toxic and inhaling them may result in unconsciousness and/or death.
- When running the engine, always make sure there is sufficient ventilation, and do not start or run the engine in an enclosed space without an effective exhaust extraction system.
-  **Warning**
Danger of burns Some vehicle components become very hot when the vehicle is operated.
- Do not touch hot components such as exhaust system, radiator, engine, shock absorber, and the brake system. Allow these components to cool down before starting work on them.

Only operate the vehicle when it is in perfect technical condition, in accordance with its intended use, and in a safe and environmentally compatible manner.

An appropriate driver's license is needed to ride the vehicle on public roads.

Have malfunctions that impair safety promptly eliminated by an authorized KTM workshop.

Adhere to the information and warning labels on the vehicle.

2.6 Protective clothing

-  **Warning**
Risk of injury Missing or poor protective clothing presents an increased safety risk.
- Wear protective clothing (helmet, boots, gloves, pants and jacket with protectors) every time you ride the vehicle. Always wear protective clothing that is in good condition and meets the legal requirements.

In the interest of your own safety, KTM recommends that you only operate the vehicle while wearing protective clothing.

2.7 Work rules

Special tools are necessary for certain tasks. The tools are not contained in the vehicle but can be ordered under the number in parentheses. E.g.: bearing puller (15112017000)

During assembly, non-reusable parts (e.g. self-locking screws and nuts, seals and seal rings, O-rings, pins, lock washers) must be replaced by new parts.

In some instances, a thread locker (e.g. **Loctite**®) is required. The manufacturer instructions for use must be followed.

After disassembly, clean the parts that are to be reused and check them for damage and wear. Change damaged or worn parts.

After you complete the repair or service work, check the operating safety of the vehicle.

2.8 Environment

If you use your motorcycle responsibly, you can ensure that problems and conflicts do not occur. To protect the future of the motorcycle sport, make sure that you use your motorcycle legally, display environmental consciousness, and respect the rights of others.

When disposing of used oil, other operating and auxiliary fluids, and used components, comply with the laws and regulations of the respective country.

Because motorcycles are not subject to the EU regulations governing the disposal of used vehicles, there are no legal regulations that pertain to the disposal of an end-of-life motorcycle. Your authorized KTM dealer will be glad to advise you.

2.9 Owner's Manual

It is important that you read this Owner's Manual carefully and completely before making your first trip. The Owner's Manual contains useful information and many tips on how to operate, handle, and maintain your motorcycle. Only then will you find out how to customize the vehicle ideally for your own use and how you can protect yourself from injury.

Keep the Owner's Manual in an accessible place to enable you to refer to it as needed.

If you would like to know more about the vehicle or have questions on the material you read, please contact an authorized KTM dealer. The Owner's Manual is an important component of the vehicle and should be handed over to the new owner if the vehicle is sold.

3.1 Guarantee, warranty

The work prescribed in the service schedule must be carried out by an authorized KTM workshop only and confirmed in the customer's Service & Warranty Booklet and in the **KTM dealer.net**; otherwise, all warranty claims will be void. No warranty claims can be considered for damage resulting from manipulations and/or alterations to the vehicle.

Additional information on the guarantee or warranty and the procedures involved can be found in the Service & Warranty Booklet.

3.2 Operating and auxiliary substances



Warning

Environmental hazard Improper handling of fuel is a danger to the environment.

- Do not allow fuel to get into the ground water, the ground, or the sewage system.

Use operating and auxiliary substances (such as fuel and lubricants) as specified in the Owner's Manual.

3.3 Spare parts, accessories

For your own safety, only use spare parts and accessory products that are approved and/or recommended by KTM and have them installed by an authorized KTM workshop. KTM accepts no liability for other products and any resulting damage or loss. Certain spare parts and accessory products are specified in parentheses in the descriptions. Your authorized KTM dealer will be glad to advise you.

The current **KTM PowerParts** for your vehicle can be found on the KTM website.

International KTM Website: <http://www.ktm.com>

3.4 Service

A prerequisite for perfect operation and prevention of premature wear is that the service, care, and tuning work on the engine and chassis is properly carried out as described in the Owner's Manual. Incorrect adjustment and tuning of the engine and chassis can lead to damage and breakage of components.

Use of the vehicle under difficult conditions, such as on sand or on wet and muddy surfaces, can lead to considerably more rapid wear of components such as the drive train, brake system, or suspension components. For this reason, it may be necessary to inspect or replace parts before the next scheduled service.

It is imperative that you adhere to the stipulated run-in times and service intervals. If you observe these exactly, you will ensure a much longer service life for your motorcycle.

3.5 Figures

The figures contained in the manual may depict special equipment.

In the interest of clarity, some components may be shown disassembled or may not be shown at all. It is not always necessary to disassemble the component to perform the activity in question. Please follow the instructions in the text.

3.6 Customer service

Your authorized KTM dealer will be happy to answer any questions you may have on your vehicle and KTM.

A list of authorized KTM dealers can be found on the KTM website.

International KTM Website: <http://www.ktm.com>

4.1 View of vehicle, front left (example)



- | | |
|---|----------------------------|
| 1 | Hand brake lever (☛ p. 14) |
| 2 | Clutch lever (☛ p. 14) |
| 3 | Filler cap |
| 4 | Shift lever (☛ p. 18) |
| 5 | Engine number (☛ p. 12) |
| 6 | Side stand (☛ p. 19) |

4.2 View of vehicle, rear right (example)

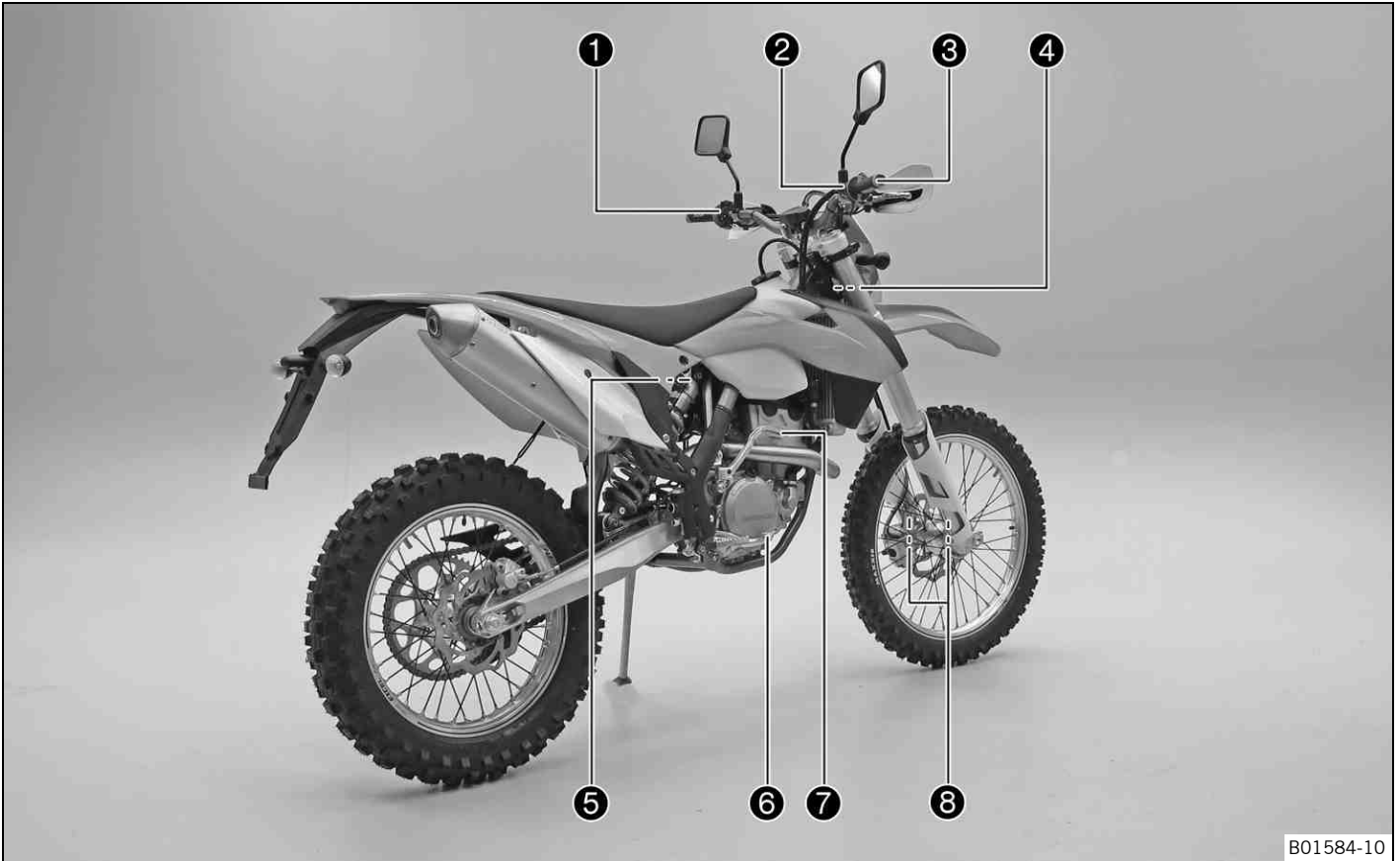

B01584-10

| | |
|---|--------------------------------------|
| 1 | Kill switch (☛ p. 14) |
| 1 | Horn button (☛ p. 15) |
| 1 | Light switch (☛ p. 15) |
| 1 | Turn signal switch (☛ p. 15) |
| 2 | Emergency OFF switch (☛ p. 15) |
| 2 | Electric starter button (☛ p. 16) |
| 3 | Throttle grip (☛ p. 14) |
| 4 | Chassis number (☛ p. 12) |
| 4 | Type label (☛ p. 12) |
| 5 | Shock absorber part number (☛ p. 13) |
| 6 | Foot brake lever (☛ p. 19) |
| 7 | Kick starter (☛ p. 18) |
| 8 | Fork part number (☛ p. 12) |

5.1 Chassis number

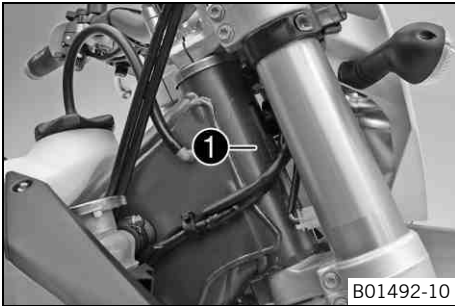

The chassis number ❶ is stamped on the steering head on the right.

5.2 Type label

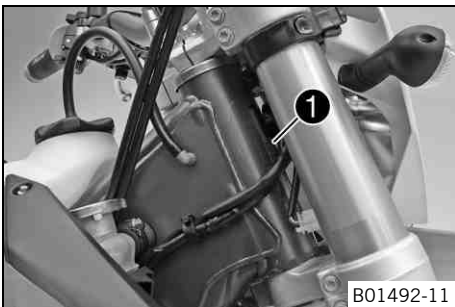

The type label ❶ is fixed to the front of the steering head.

5.3 Key number (All EXC-F models)

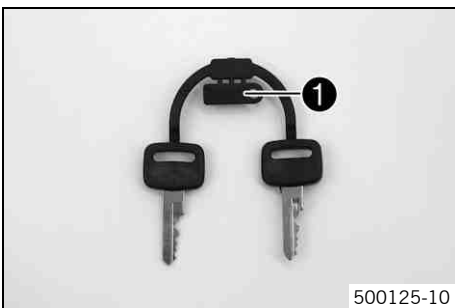

The key number ❶ for the steering lock is stamped onto the key connector.

5.4 Engine number

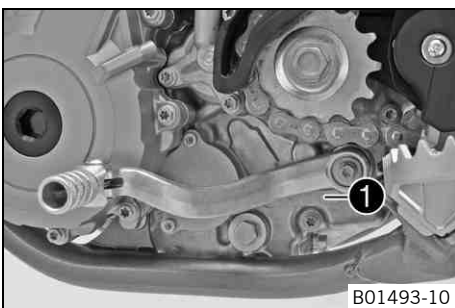

The engine number ❶ is stamped on the left side of the engine under the engine sprocket.

5.5 Fork part number

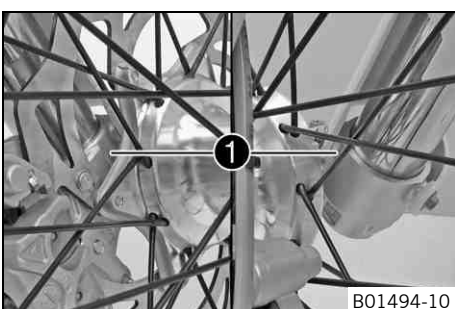

The fork part number ❶ is stamped on the inner side of the fork stub.

5.6 Shock absorber part number

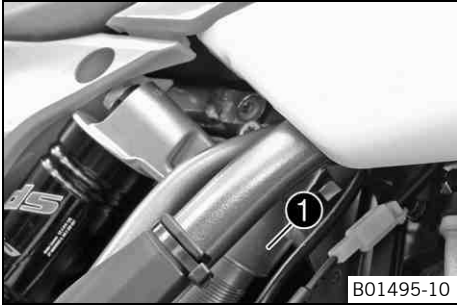

The shock absorber part number ❶ is stamped on the top of the shock absorber above the adjusting ring on the engine side.

6.1 Clutch lever

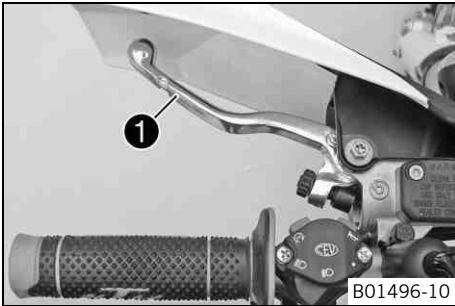

The clutch lever ❶ is fitted on the left side of the handlebar. The clutch is hydraulically operated and self-adjusting.

6.2 Hand brake lever

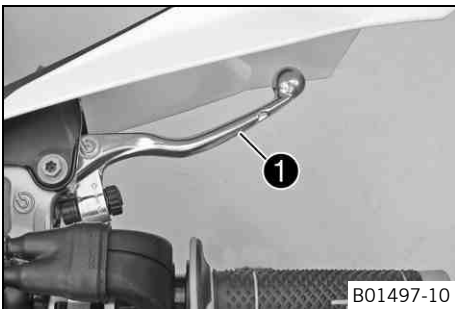

Hand brake lever ❶ is located on the right side of the handlebar. The hand brake lever is used to activate the front brake.

6.3 Throttle grip

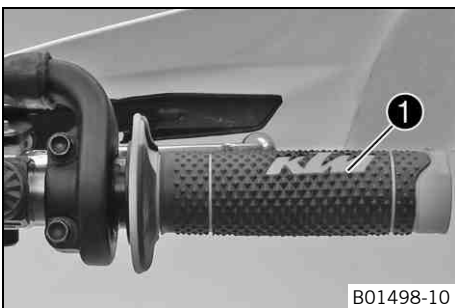

The throttle grip ❶ is fitted on the right side of the handlebar.

6.4 Kill switch (All EXC-F models)

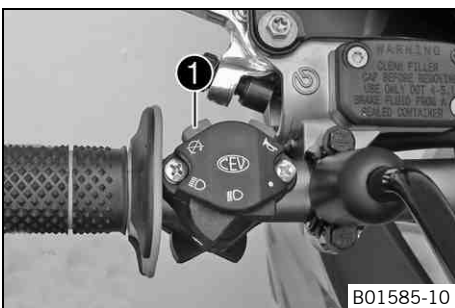

Kill switch ❶ is fitted on the left side of the handlebar.

Possible states

- Kill switch ☒ in basic position – the ignition circuit is closed in this position and the engine can be started.
- Kill switch ☒ pressed – the ignition circuit is open in this position, the engine goes out if it was running, or does not start if it was off.

6.5 Kill switch (XCF-W)

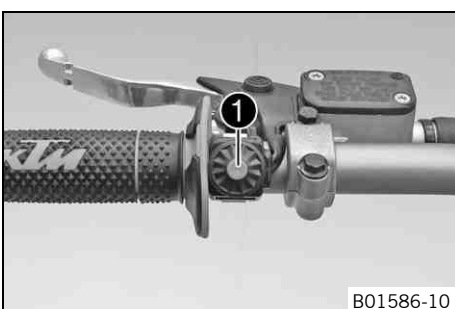

Kill switch ❶ is fitted on the left side of the handlebar.

Possible states

- Kill switch ☒ in basic position – the ignition circuit is closed in this position and the engine can be started.
- Kill switch ☒ pressed – the ignition circuit is open in this position, the engine goes out if it was running, or does not start if it was off.

6.6 Horn button (All EXC-F models)

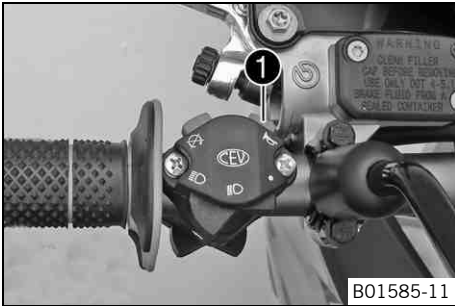

The horn button ❶ is fitted on the left side of the handlebar.

Possible states

- Horn button in neutral position
- Horn button pressed – the horn is actuated in this position.

6.7 Light switch (All EXC-F models)

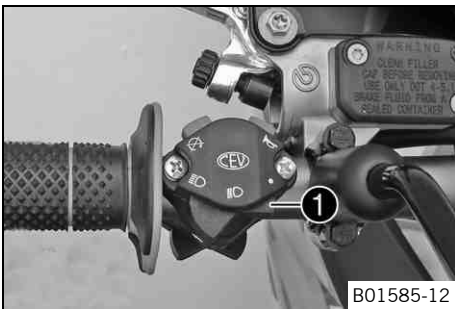

The light switch ❶ is fitted on the left side of the handlebar.

Possible states

| | |
|---|--|
| ● | Light off – Light switch is turned to the right. In this position, the light is switched off. |
| | Low beam on – Light switch is in the central position. In this position, the low beam and tail light are switched on. |
| | High beam on – Light switch is turned to the left. In this position, the high beam and the tail light are switched on. |

6.8 Light switch (XCF-W)



The light switch ❶ is on the right of the speedometer.

Possible states

- Light off – Light switch is pressed in up to the stop. In this position, the light is switched off.
- Light on – Light switch is pulled out to the stop. In this position, the low beam and tail light are switched on.

6.9 Turn signal switch (All EXC-F models)

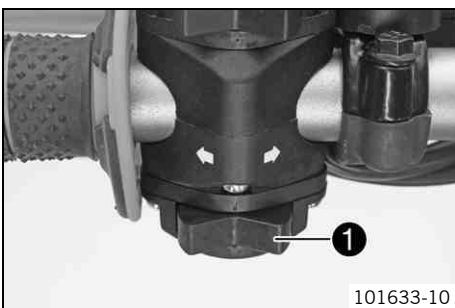

Turn signal switch ❶ is fitted on the left side of the handlebar.

Possible states

| | |
|--|---|
| | Turn signal light off – Turn signal switch is in the central position. |
| | Turn signal light, left, on – Turn signal switch is turned to the left. |
| | Turn signal light, right, on – Turn signal switch is turned to the right. |

6.10 Emergency OFF switch (EXC-F AUS)

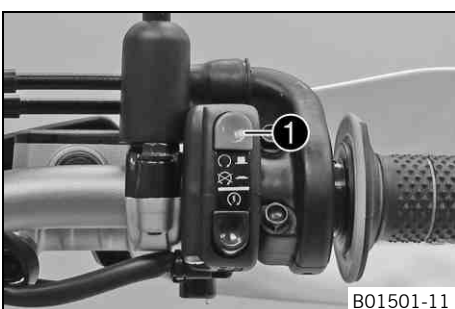

The emergency OFF switch ❶ is fitted on the right side of the handlebar.

Possible states

| | |
|--|---|
| | Ignition off – the ignition circuit is open in this position, the engine goes out if it was running, or does not start if it was off. |
| | Ignition on – the ignition circuit is closed in this position and the engine can be started. |

6.11 Electric starter button (EXC-F EU, EXC-F SIX DAYS, XCF-W)

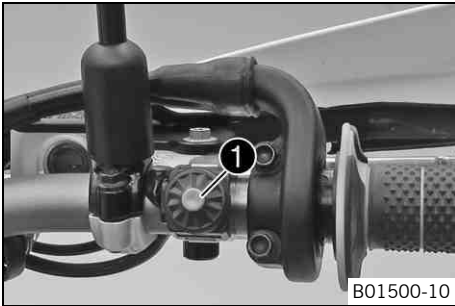

The electric starter button ❶ is fitted on the right side of the handlebar.

Possible states

- Electric starter button ❸ in basic position
- Electric starter button ❸ pressed – the electric starter is actuated in this position.

6.12 Electric starter button (EXC-F AUS)

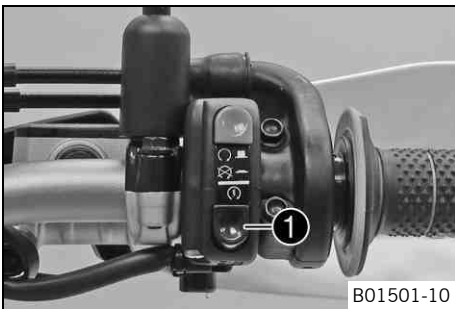

The electric starter button ❶ is fitted on the right side of the handlebar.

Possible states

- Electric starter button ❸ in basic position
- Electric starter button ❸ pressed – the electric starter is actuated in this position.

6.13 Overview of indicator lamps (EXC-F EU, EXC-F AUS)



Possible states

| | |
|--|--|
| | The high beam indicator lamp lights up blue – The high beam is switched on. |
| | FI warning lamp (MIL) lights up/flashes orange – The OBD has detected an emission- or safety-critical fault. |
| | The low fuel warning lamp lights up orange – The fuel level has reached the reserve mark. |
| | Turn signal indicator light flashes green – The turn signal is switched on. |

6.14 Overview of indicator lamps (EXC-F SIX DAYS)



Possible states

| | |
|--|---|
| | The high beam indicator lamp lights up blue – The high beam is switched on. |
| | EFI warning lamp (MIL) lights up/flashes orange – The OBD has detected an emission- or safety-critical fault. |
| | The low fuel warning lamp lights up orange – The fuel level has reached the reserve mark. |
| | Turn signal indicator light flashes green – The turn signal is switched on. |

6.15 Overview of indicator lamps (XCF-W)



Possible states

| | |
|--|--|
| | FI warning lamp (MIL) lights up/flashes orange – The OBD has detected an emission- or safety-critical fault. |
| | The low fuel warning lamp lights up orange – The fuel level has reached the reserve mark. |

6.16 Opening filler cap

- Danger**
Fire hazard Fuel is highly flammable.
- Never refuel the vehicle near open flames or burning cigarettes, and always switch off the engine first. Be careful that no fuel is spilt, especially on hot vehicle components. Clean up spilt fuel immediately.
 - The fuel in the fuel tank expands when warm and may emerge if overfilled. Follow the instructions on refueling.

- Warning**
Danger of poisoning Fuel is poisonous and a health hazard.
- Fuel must not come into contact with the skin, eyes, or clothing. Do not breathe in the fuel vapors. If contact occurs with the eyes, rinse with water immediately and contact a physician. Immediately clean contaminated areas on the skin with soap and water. If fuel is swallowed, contact a physician immediately. Change clothing that is contaminated with fuel. Store fuel properly in a suitable canister and keep away from children.

- Warning**
Environmental hazard Improper handling of fuel is a danger to the environment.
- Do not allow fuel to get into the ground water, the ground, or the sewage system.

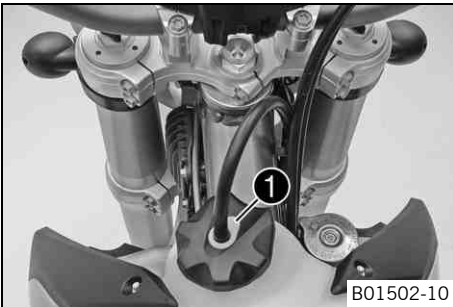

- Press release button **1**, turn filler cap counterclockwise and lift it upwards and remove.

6.17 Closing filler cap

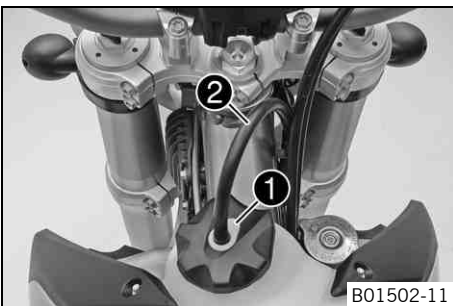

- Replace the filler cap and turn clockwise until the release button **1** locks in place.

i Info
Route the fuel tank breather hose **2** without kinking.

6.18 Idle speed adjusting screw

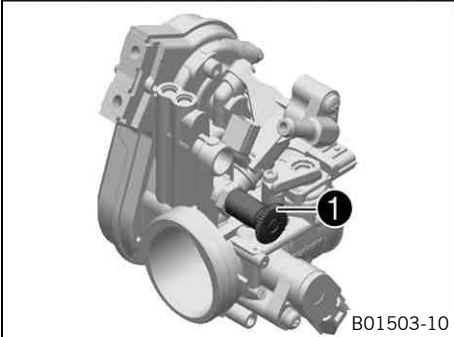
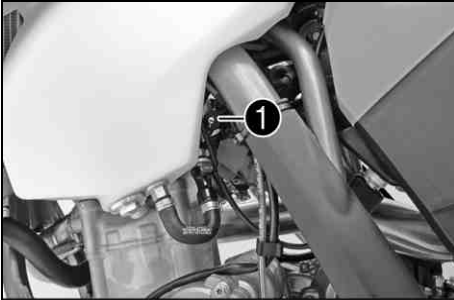

B01503-10

The idle speed adjusting screw ❶ is located on the throttle valve body at the top left. The idle speed adjusting screw has two functions. Turning it controls the idle speed. Pulling it out all the way raises the idle speed during a cold start.

Possible states

- RPM increase activated – Idle speed adjusting screw is pulled out all the way.
- RPM increase deactivated – Idle speed adjusting screw is pushed in all the way.

6.19 Shift lever

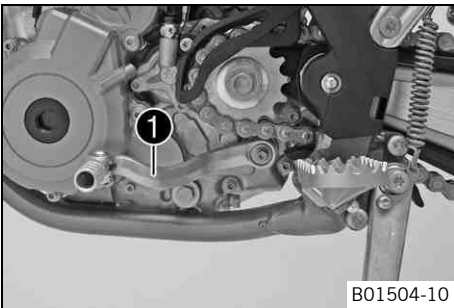

B01504-10

Shift lever ❶ is mounted on the left side of the engine.

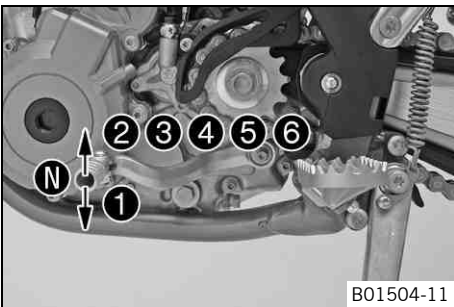

B01504-11

The gear positions can be seen in the photograph. The neutral or idle position is between the first and second gears.

6.20 Kick starter

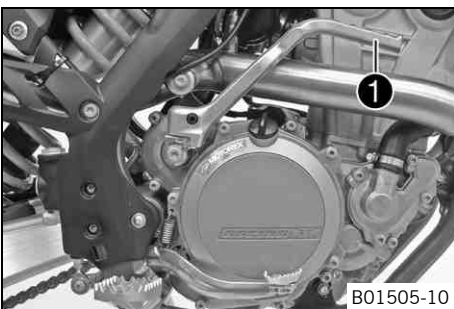

B01505-10

The kick starter ❶ is fitted on the right of the engine. The engine can be started with either the kick starter or the electric starter. The upper part of the kick starter can be swung out.

i Info

Before riding, swing the upper part of the kick starter inwards towards the engine.

6.21 Foot brake lever

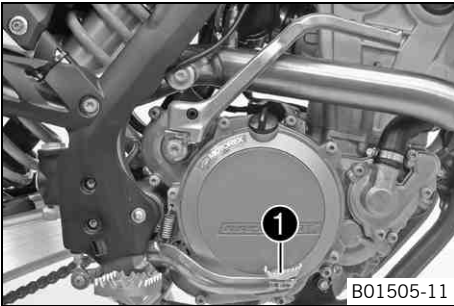

Foot brake lever ❶ is located in front of the right footrest. The foot brake lever is used to activate the rear brake.

6.22 Side stand

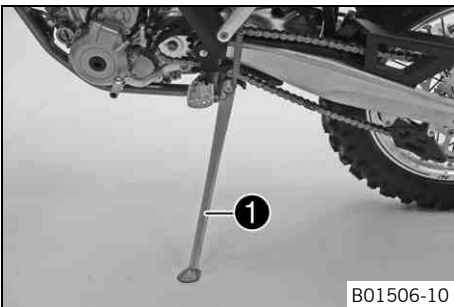

The side stand ❶ is on the left side of the vehicle.

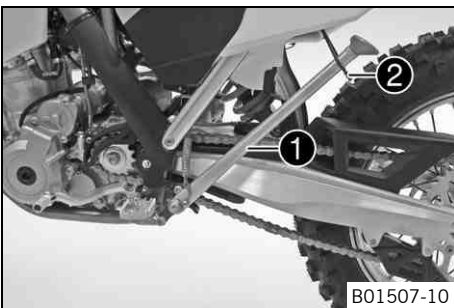

The side stand is used to park the motorcycle.

i Info
When you are riding, the side stand ❶ must be folded up and secured with the rubber band ❷.

6.23 Steering lock (All EXC-F models)

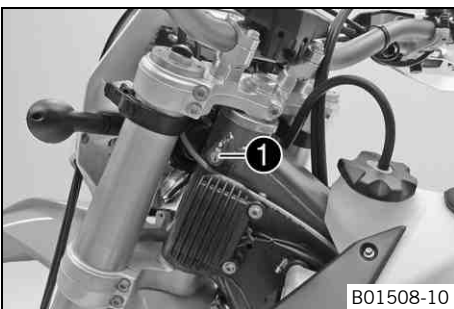

Steering lock ❶ is fitted on the left side of the steering head. The steering lock is used to lock the steering. Steering, and therefore riding, is no longer possible.

6.24 Locking the steering (All EXC-F models)

Note

Danger of damage The parked vehicle may roll away or fall over.

- Always place the vehicle on a firm and even surface.

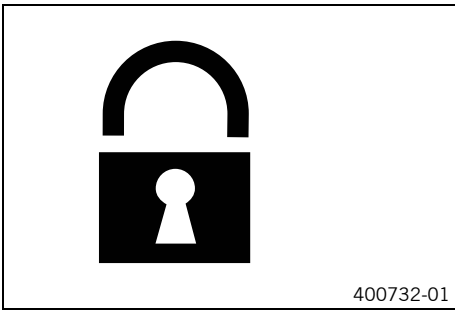

- Park the vehicle.
 - Turn the handlebar as far as possible to the right.
 - Insert the key in the steering lock, turn it to the left, press it in and turn it to the right. Remove the key.
- ✓ Steering is no longer possible.



Info

Never leave the key in the steering lock.

6.25 Unlocking the steering (All EXC-F models)

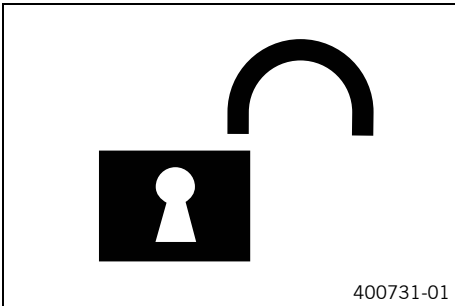

- Insert the key in the steering lock, turn it to the left, pull it out and turn it to the right. Remove the key.
- ✓ You can now steer the bike again.



Info

Never leave the key in the steering lock.

7.1 EXC-F EU, EXC-F AUS, XCF-W

7.1.1 Speedometer overview

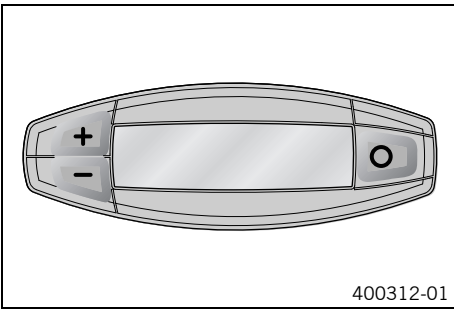

- Press the button to change the display mode or change to one of the Setup menus.
- Press the button to control different functions.
- Press the button to control different functions.

i Info
When the vehicle is delivered, only the **SPEED/H** and **SPEED/ODO** display modes are activated.

7.1.2 Activation and test

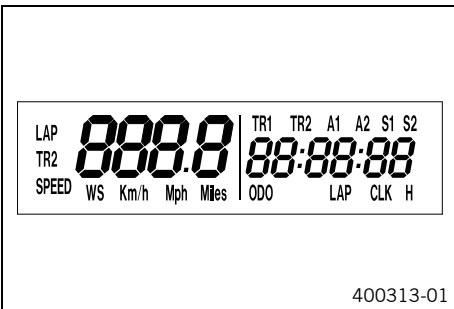

Activating the speedometer

The speedometer is activated when one of the buttons is pressed or an impulse comes from the wheel speed sensor.

Display test

To enable you to check that the display is functioning properly, all display segments light up briefly.

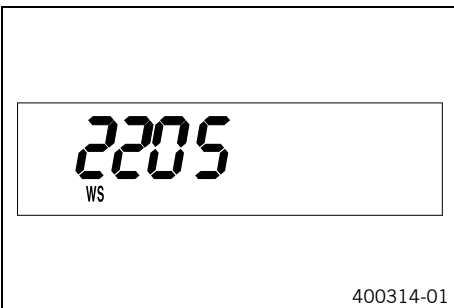

WS (wheel size)

After the display function check, the wheel size **WS** is displayed briefly.

i Info
The number 2205 equals the circumference of the 21" front wheel with standard tires.

The display then changes to the last selected mode.

7.1.3 Setting kilometers or miles

i Info
If you change the unit of measure, the **ODO** value is retained and converted accordingly. The values **TR1**, **TR2**, **A1**, **A2** and **S1** are cleared when the unit of measure is changed.

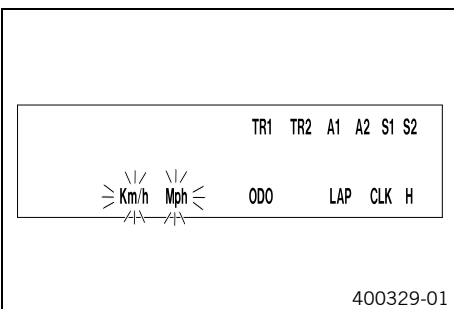

Condition

The motorcycle is stationary.

- Press the button briefly and repeatedly until **H** appears at the bottom right of the display.
- Press the button for 3 - 5 seconds.
 - ✓ The Setup menu is displayed and the active functions are shown.
- Press the button repeatedly until the **Km/h/Mph** display flashes.

Adjusting Km/h

- Press the button .

Adjusting Mph

- Press the button .
- Press the button for 3 - 5 seconds.
 - ✓ The settings are stored and the Setup menu is closed.

i Info
If no button is pressed for 20 seconds, or if no impulse comes from the wheel speed sensor, the settings are automatically saved and the Setup menu is closed.

7.1.4 Adjusting the speedometer functions

**Info**

When the vehicle is delivered, only the **SPEED/H** and **SPEED/ODO** display modes are activated.

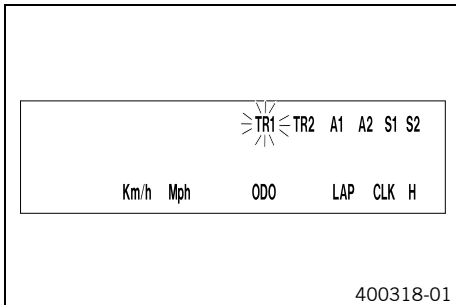
**Condition**

The motorcycle is stationary.

- Press the button briefly and repeatedly until **H** appears at the bottom right of the display.
- Press the button for 3 - 5 seconds.
 - ✓ The Setup menu is displayed and the activated functions are shown.
- Change to the desired function by pressing the button briefly.
 - ✓ The selected function flashes.

Activating a function

- Press the button .
- ✓ The symbol remains on the screen and the display changes to the next function.

Deactivating the function

- Press the button .
- ✓ The symbol on the screen goes out and the display changes to the next function.
- All desired functions are activated or deactivated accordingly.
- Press the button for 3 - 5 seconds.
 - ✓ The settings are stored and the Setup menu is closed.

**Info**

If no button is pressed for 20 seconds, or if no impulse comes from the wheel speed sensor, the settings are automatically saved and the Setup menu is closed.

7.1.5 Setting the clock

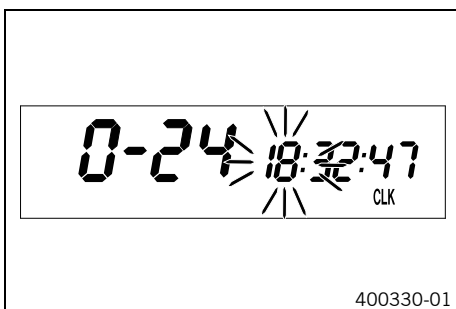
**Condition**

The motorcycle is stationary.

- Press the button briefly and repeatedly until **CLK** appears at the bottom right of the display.
- Press the button for 3 - 5 seconds.
 - ✓ The hour display flashes.
- Set the hour display with the button and/or button .
- Press the button briefly.
 - ✓ The next segment of the display flashes and can be set.
- You can set the following segments in the same way as the hours by pressing the button and the button .

**Info**

The seconds can only be set to zero.

- Press the button for 3 - 5 seconds.
 - ✓ The settings are stored and the Setup menu is closed.

**Info**

If no button is pressed for 20 seconds, or if no impulse comes from the wheel speed sensor, the settings are automatically saved and the Setup menu is closed.

7.1.6 Querying lap time

**Info**

This function can be called up only if lap times are measured.

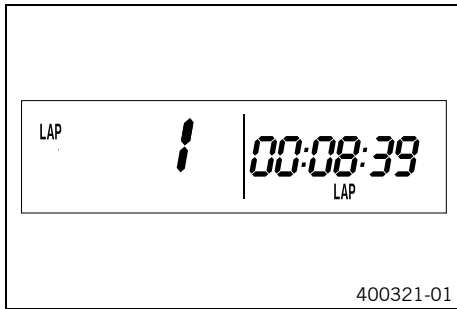

Condition

The motorcycle is stationary.

- Press the button briefly and repeatedly until **LAP** appears at the bottom right of the display.
- Press the button briefly.
 - ✓ **LAP 1** appears on the left side of the display.
- Laps 1-10 can be displayed by pressing the button .
- The button has no function.
- Press the button briefly.
 - ✓ Next display mode



Info

If an impulse is received from the wheel speed sensor, the left side of the display changes back to the **SPEED** mode.

7.1.7 Display mode SPEED (speed)

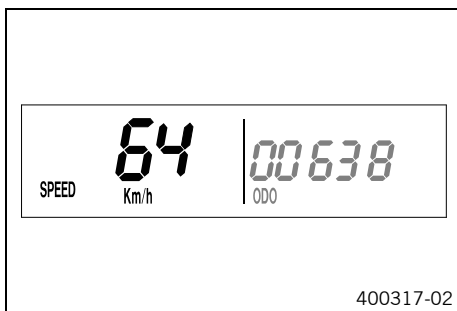

- Press the button briefly and repeatedly until **SPEED** appears on the left side of the display.

The current speed is displayed in the **SPEED** display mode.
The current speed can be displayed in **Km/h** or **Mph**.



Info

Making the setting according to the country.
When an impulse comes from the front wheel, the left side of the speedometer display changes to the **SPEED** mode and the current speed is shown.

7.1.8 Display mode SPEED/H (service hours)



Condition

- The motorcycle is stationary.
- Press the button briefly and repeatedly until **H** appears at the bottom right of the display.

In display mode **H**, the service hours of the engine are displayed.
The service hour counter stores the total traveling time.



Info

The service hour counter is necessary for ensuring that service work is carried out at the right intervals.
If the speedometer is in **H** display mode at the start of the journey, it automatically changes to the **ODO** display mode.
The **H** display mode is suppressed during the journey.

| | |
|--------------------------------------|---|
| Press the button . | No function |
| Press the button . | No function |
| Press the button for 3 - 5 seconds. | The display changes to the Setup menu of the speedometer functions. |
| Press the button briefly. | Next display mode |

7.1.9 Setup menu

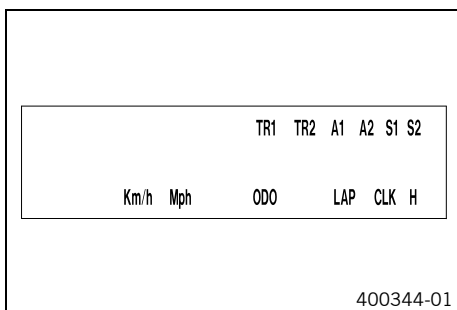

Condition

- The motorcycle is stationary.
- Press the button briefly and repeatedly until **H** appears at the bottom right of the display.
- Press the button for 3 - 5 seconds.

The Setup menu displays the active functions.



Info

If no button is pressed for 20 seconds, the settings are automatically stored.

| | |
|--|---|
| Press the button + . | Activates the flashing display |
| Press the button - . | Deactivates the flashing display |
| Press the button ○ briefly. | Changes to the next display without changes |
| Press the button ○ for 3 - 5 seconds. | Setup menu starts, stores the settings, and changes to H or ODO . |

7.1.10 Unit of measurement menu

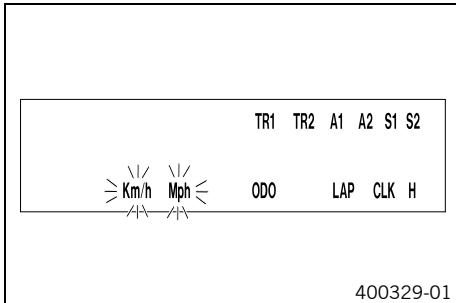

Condition

- The motorcycle is stationary.
- Press the button **○** briefly and repeatedly until **H** appears at the bottom right of the display.
- Press the button **-**.

In measurement unit mode, you can change the unit of measurement.

Info

If no button is pressed for 20 seconds, the settings are automatically stored.

| | |
|--|---|
| Press the button + . | Starts selection, activates Km/h display |
| Press the button - . | Activates Mph display |
| Press the button ○ briefly. | Changes to the next display, changes from selection to the Setup menu |
| Press the button ○ for 3 - 5 seconds. | Saves and closes the Setup menu |

7.1.11 Display mode SPEED/CLK (time)

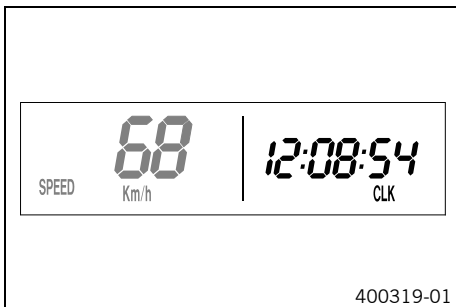

- Press the button **○** briefly and repeatedly until **CLK** appears at the bottom right of the display.

The time is shown in display mode **CLK**.

| | |
|--|---|
| Press the button + . | No function |
| Press the button - . | No function |
| Press the button ○ for 3 - 5 seconds. | The display changes to the Setup menu of the clock. |
| Press the button ○ briefly. | Next display mode |

7.1.12 Setting the clock

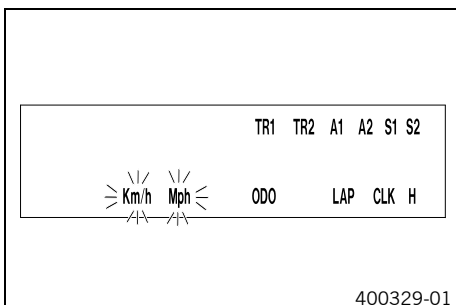

Condition

- The motorcycle is stationary.
- Press the button **○** briefly and repeatedly until **CLK** appears at the bottom right of the display.
- Press the button **○** for 3 - 5 seconds.

| | |
|--|---------------------------------|
| Press the button + . | Increases the value |
| Press the button - . | Reduces the value |
| Press the button ○ briefly. | Changes to the next value |
| Press the button ○ for 3 - 5 seconds. | Starts and exits the SETUP menu |

7.1.13 Display mode SPEED/LAP (lap time)

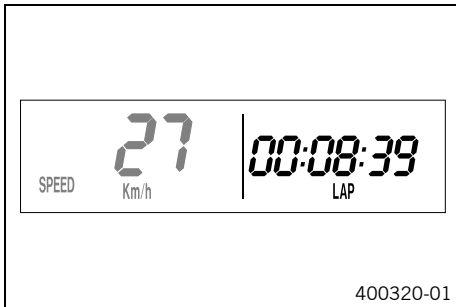

- Press the button briefly and repeatedly until **LAP** appears at the bottom right of the display.

In the **LAP** display mode, up to 10 lap times can be timed with the stop watch.

i Info
If the lap time continues running after the button is pressed, 9 memory locations are occupied.
Lap 10 must be timed using the button .

| | |
|--------------------------------------|---|
| Press the button . | Starts or stops the clock. |
| Press the button . | Times the current lap time, stores it and the stop watch starts the next lap. |
| Press the button for 3 - 5 seconds. | The stop watch and the lap time are reset. |
| Press the button briefly. | Next display mode |

7.1.14 Viewing the lap time

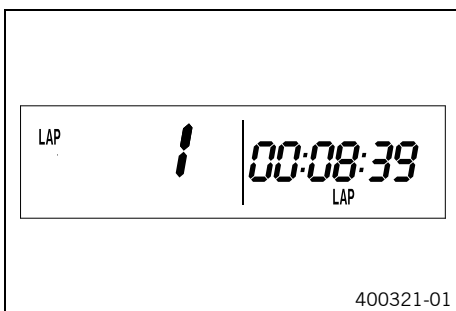

Condition

- The motorcycle is stationary.
- Press the button briefly and repeatedly until **LAP** appears at the bottom right of the display.
- Briefly press the button .

| | |
|--------------------------------------|------------------------|
| Press the button . | Select a lap from 1–10 |
| Press the button . | No function |
| Press the button for 3 - 5 seconds. | No function |
| Press the button briefly. | Next display mode |

7.1.15 Display mode SPEED/ODO (odometer)

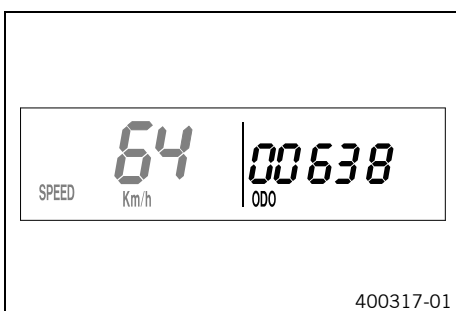

- Press the button briefly and repeatedly until **ODO** appears at the bottom right of the display.

The total distance traveled is displayed in the **ODO** display mode.

| | |
|--------------------------------------|-------------------|
| Press the button . | No function |
| Press the button . | No function |
| Press the button for 3 - 5 seconds. | No function |
| Press the button briefly. | Next display mode |

7.1.16 Display mode SPEED/TR1 (trip master 1)

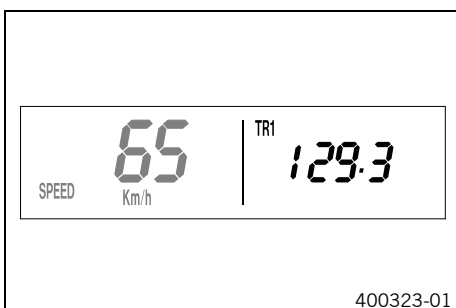

- Press the button briefly and repeatedly until **TR1** appears at the top right of the display.

TR1 (trip master 1) runs constantly and counts to 999.9.

You can use it to measure trips or the distance between refueling stops.

TR1 is coupled with **A1** (average speed 1) and **S1** (stop watch 1).

i Info
If 999.9 is exceeded, the values of **TR1**, **A1** and **S1** are automatically reset to 0.0.

| | |
|--------------------------------------|---|
| Press the button . | No function |
| Press the button . | No function |
| Press the button for 3 - 5 seconds. | The TR1 , A1 and S1 displays are reset to 0.0. |



| | |
|---|-------------------|
| Press the button  briefly. | Next display mode |
|---|-------------------|

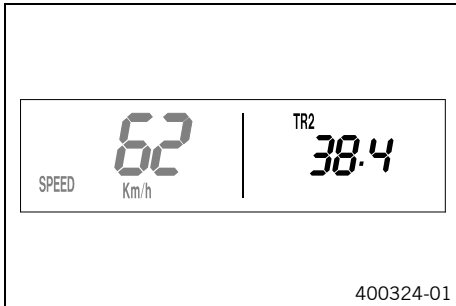

7.1.17 Display mode SPEED/TR2 (trip master 2)







- Press the button  briefly and repeatedly until **TR2** appears at the top right of the display.

TR2 (trip master 2) runs constantly and counts up to 999.9.

The displayed value can be set manually with the button  and the button . This is a very practical function when riding using the road book.



i Info
The **TR2** value can also be corrected manually during the journey with the button  and the button . If 999.9 is exceeded, the value of **TR2** is automatically reset to 0.0.

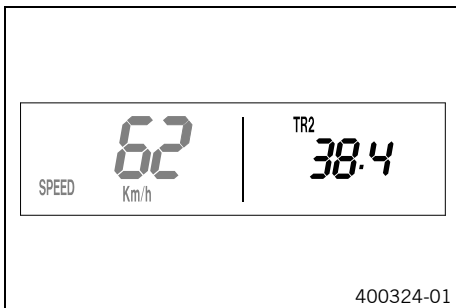

| | |
|---|---------------------------------|
| Press the button  . | Increases value of TR2 . |
| Press the button  . | Reduces value of TR2 . |
| Press the button  for 3 - 5 seconds. | Deletes value of TR2 . |
| Press the button  briefly. | Next display mode |



7.1.18 Setting TR2 (trip master 2)







Condition

- The motorcycle is stationary.
- Press the button  briefly and repeatedly until **TR2** appears at the top right of the display.
- Press the button  for 2–3 seconds until **TR2** flashes.

The displayed value can be set manually with the button  and the button . This is a very practical function when riding using the road book.

i Info
The **TR2** value can also be corrected manually during the journey with the button  and the button . If 999.9 is exceeded, the value of **TR2** is automatically reset to 0.0.

| | |
|---|---------------------------------|
| Press the button  . | Increases value of TR2 . |
| Press the button  . | Reduces value of TR2 . |
| Press the button  for 3 - 5 seconds. | Deletes value of TR2 . |
| Press the button  briefly. | Next display mode |





7.1.19 Display mode SPEED/A1 (average speed 1)



- Press the button  briefly and repeatedly until **A1** appears at the top right of the display.

A1 (average speed 1) shows the average speed calculated on the basis of **TR1** (trip master 1) and **S1** (stop watch 1).

The calculation of this value is activated by the first impulse of the wheel speed sensor and ends 3 seconds after the last impulse.

| | |
|---|---|
| Press the button  . | No function |
| Press the button  . | No function |
| Press the button  for 3 - 5 seconds. | The TR1 , A1 and S1 displays are reset to 0.0. |
| Press the button  briefly. | Next display mode |

7.1.20 Display mode SPEED/A2 (average speed 2)



- Press the button briefly and repeatedly until **A2** appears at the top right of the display.

A2 (average speed 2) shows the average speed on the basis of the current speed if the stop watch **S2** (stop watch 2) is running.

i Info
The displayed value can differ from the actual average speed if **S2** is not stopped after the ride.

| | |
|--------------------------------------|--|
| Press the button . | No function |
| Press the button . | No function |
| Press the button for 3 - 5 seconds. | Displays of TR2 , A2 and S2 are reset to 0,0. |
| Press the button briefly. | Next display mode |

7.1.21 Display mode SPEED/S1 (stop watch 1)

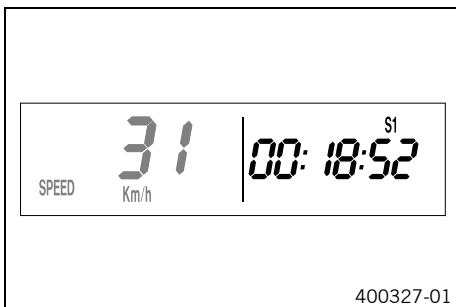

- Press the button briefly and repeatedly until **S1** appears at the top right of the display.

S1 (stop watch 1) displays the journey time on the basis of **TR1** and continues when an impulse is received from the wheel speed sensor.

The calculation of this value starts with the first impulse of the wheel speed sensor and ends 3 seconds after the last impulse.

| | |
|--------------------------------------|--|
| Press the button . | No function |
| Press the button . | No function |
| Press the button for 3 - 5 seconds. | Displays of TR1 , A1 and S1 are reset to 0.0. |
| Press the button briefly. | Next display mode |

7.1.22 Display mode SPEED/S2 (stop watch 2)



- Press the button briefly and repeatedly until **S2** appears at the top right of the display.

S2 (stop watch 2) is a manual stop watch.

If **S2** is running in the background, the **S2** display flashes in the speedometer display.

| | |
|--------------------------------------|---|
| Press the button . | Starts or stops S2 . |
| Press the button . | No function |
| Press the button for 3 - 5 seconds. | Displays of S2 and A2 are reset to 0.0. |
| Press the button briefly. | Next display mode |

7.1.23 Table of functions

| Display | Press the button . | Press the button . | Press the button for 3 - 5 seconds. | Press the button briefly. |
|---|---|----------------------------------|---|---|
| Display mode SPEED/H (service hours) | No function | No function | The display changes to the Setup menu of the speedometer functions. | Next display mode |
| Setup menu | Activates the flashing display | Deactivates the flashing display | Setup menu starts, stores the settings, and changes to H or ODO . | Changes to the next display without changes |
| Unit of measurement menu | Starts selection, activates Km/h display | Activates Mph display | Saves and closes the Setup menu | Changes to the next display, changes from selection to the Setup menu |
| Display mode SPEED/CLK (time) | No function | No function | The display changes to the Setup menu of the clock. | Next display mode |

| Display | Press the button + . | Press the button - . | Press the button ○ for 3 - 5 seconds. | Press the button ○ briefly. |
|--|---------------------------------|---|---|------------------------------------|
| Setting the clock | Increases the value | Reduces the value | Starts and exits the SETUP menu | Changes to the next value |
| Display mode SPEED/LAP (lap time) | Starts or stops the clock. | Times the current lap time, stores it and the stop watch starts the next lap. | The stop watch and the lap time are reset. | Next display mode |
| Viewing the lap time | Select a lap from 1–10 | No function | No function | Next display mode |
| Display mode SPEED/ODO (odometer) | No function | No function | No function | Next display mode |
| Display mode SPEED/TR1 (trip master 1) | No function | No function | The TR1 , A1 and S1 displays are reset to 0.0. | Next display mode |
| Display mode SPEED/TR2 (trip master 2) | Increases value of TR2 . | Reduces value of TR2 . | Deletes value of TR2 . | Next display mode |
| Setting TR2 (trip master 2) | Increases value of TR2 . | Reduces value of TR2 . | Deletes value of TR2 . | Next display mode |
| Display mode SPEED/A1 (average speed 1) | No function | No function | The TR1 , A1 and S1 displays are reset to 0.0. | Next display mode |
| Display mode SPEED/A2 (average speed 2) | No function | No function | Displays of TR2 , A2 and S2 are reset to 0,0. | Next display mode |
| Display mode SPEED/S1 (stop watch 1) | No function | No function | Displays of TR1 , A1 and S1 are reset to 0.0. | Next display mode |
| Display mode SPEED/S2 (stop watch 2) | Starts or stops S2 . | No function | Displays of S2 and A2 are reset to 0.0. | Next display mode |

7.1.24 Table of conditions and menu activation

| Display | The motorcycle is stationary. | Menu can be activated |
|--|-------------------------------|-----------------------|
| Display mode SPEED/H (service hours) | • | |
| Setup menu | • | |
| Unit of measurement menu | • | |
| Setting the clock | • | |
| Display mode SPEED/LAP (lap time) | | • |
| Viewing the lap time | • | |
| Display mode SPEED/TR1 (trip master 1) | | • |
| Display mode SPEED/TR2 (trip master 2) | | • |
| Setting TR2 (trip master 2) | • | |
| Display mode SPEED/A1 (average speed 1) | | • |
| Display mode SPEED/A2 (average speed 2) | | • |
| Display mode SPEED/S1 (stop watch 1) | | • |
| Display mode SPEED/S2 (stop watch 2) | | • |

7.2 EXC-F SIX DAYS

7.2.1 Speedometer overview

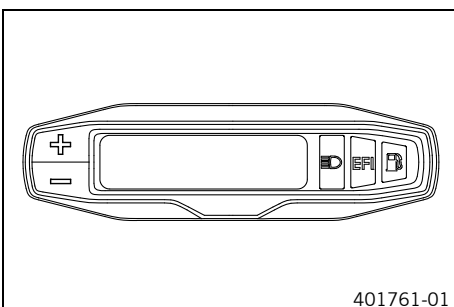

401761-01

- Press the button **+** to control different functions.
- Press the button **-** to control different functions.

i Info
When the vehicle is delivered, only the **SPEED/H** and **SPEED/ODO** display modes are activated.

7.2.2 Activation and test

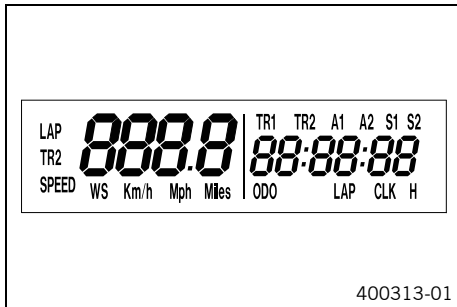

Activating the speedometer

The speedometer is activated when one of the buttons is pressed or an impulse comes from the wheel speed sensor.

Display test

To enable you to check that the display is functioning properly, all display segments light up briefly.

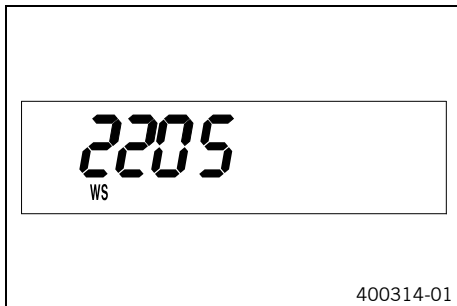

WS (wheel size)

After the display function check, the wheel size **WS** is displayed briefly.

Info

The number 2205 equals the circumference of the 21" front wheel with standard tires.

The display then changes to the last selected mode.

7.2.3 Setting kilometers or miles

Info

If you change the unit, the value **ODO** is retained and converted accordingly. The values **TR1**, **TR2**, **A1**, **A2** and **S1** are cleared when the unit of measure is changed.

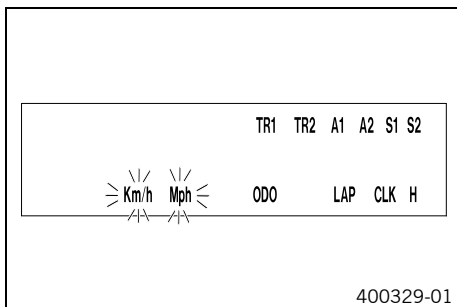

Condition

The motorcycle is stationary.

- Repeatedly press the button briefly until **H** appears at the bottom right of the display.
- Press the button for 2–3 seconds.
 - ✓ The Setup menu is displayed and the active functions are shown.
- Repeatedly press the button briefly until **Km/h/Mph** flashes.

Setting the Km/h

- Press the button .

Setting the Mph

- Press the button .
- Wait 3–5 seconds
- ✓ The settings are stored.

Info

If no button is actuated for 10–12 seconds or there is no signal from the wheel speed sensor, then the settings are automatically stored and the Setup menu is closed.

7.2.4 Setting the speedometer functions

Info

When the vehicle is delivered, only the **SPEED/H** and **SPEED/ODO** display modes are activated.

Condition

The motorcycle is stationary.

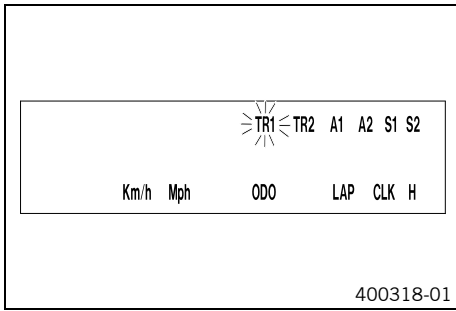

- Repeatedly press the button briefly until **H** appears at the bottom right of the display.
- Press the button for 2–3 seconds.
- ✓ The Setup menu is displayed and the active functions are shown.

i Info

If no button is pressed for 10–12 seconds, the settings are automatically stored.
If no button is actuated for 20 seconds or there is no signal from the wheel speed sensor, then the settings are automatically stored and the Setup menu is closed.

- Repeatedly press the button briefly until the desired function flashes.
- ✓ The selected function flashes.

Activating the function

- Press the button .
- ✓ The symbol continues to appear in the display and the next function appears.

Deactivating a function

- Press the button .
- ✓ The symbol disappears in the display and the next function appears.

7.2.5 Setting the clock

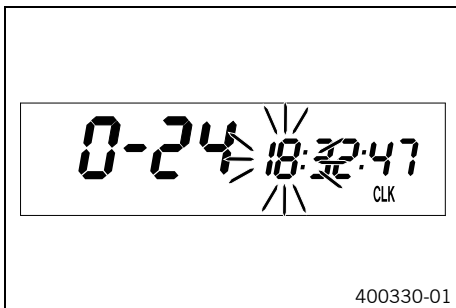

Condition

The motorcycle is stationary.

- Repeatedly press the button briefly until **CLK** appears at the bottom right of the display.
- Press the button for 2–3 seconds.
- ✓ The hour display flashes.
- Set the hour display with the button and/or button .
- Wait 3–5 seconds
- ✓ The next segment of the display flashes and can be set.
- You can set the following segments in the same way as the hours by pressing the button and the button .

i Info

The seconds can only be set to zero.
If no button is actuated for 15–20 seconds or there is no signal from the wheel speed sensor, then the settings are automatically stored and the Setup menu is closed.

7.2.6 Viewing the lap time

i Info

This function can only be opened if lap times have actually been timed.

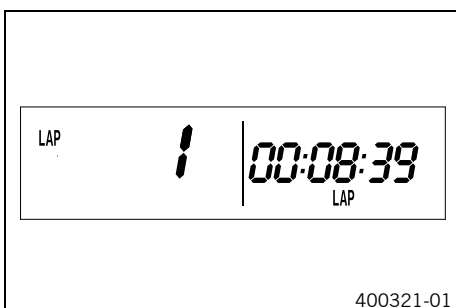

Condition

The motorcycle is stationary.

- Repeatedly press the button briefly until **LAP** appears at the bottom right of the display.
- Briefly press the button .
- ✓ **LAP 1** appears on the left side of the display.
- The laps 1–10 can be viewed with the button .
- Press and hold the button for 3–5 seconds to clear the lap times.
- Briefly press the button .
- ✓ Next display mode

i Info

When a signal from the wheel speed sensor arrives, the left side of the display changes back to the **SPEED** mode.

7.2.7 Display mode SPEED (speed)

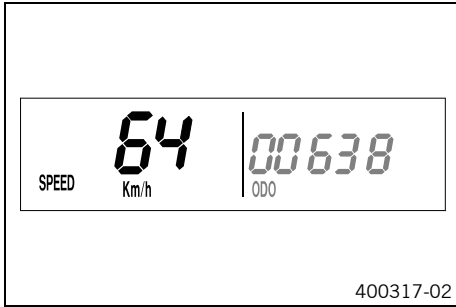

400317-02

- Repeatedly press the button briefly until **SPEED** appears on the left side of the display.

The current speed is displayed in the **SPEED** display mode.
The current speed can be displayed in **Km/h** or **Mph**.

Info

Making the setting according to the country.
When an impulse comes from the front wheel, the left side of the speedometer display changes to the **SPEED** mode and the current speed is shown.

7.2.8 Display mode SPEED/H (service hours)

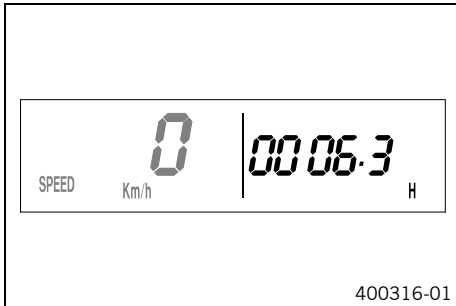

400316-01

Condition

- The motorcycle is stationary.
- Repeatedly press the button briefly until **H** appears at the bottom right of the display.

In display mode **H**, the service hours of the engine are displayed.
The service hour counter stores the total traveling time.

Info

The service hour counter is necessary for ensuring that service work is carried out at the right intervals.
If the speedometer is in **H** display mode at the start of the journey, it automatically changes to the **ODO** display mode.
The **H** display mode is suppressed during the journey.

| | |
|------------------------------------|---|
| Press the button for 2–3 seconds. | The display changes to the Setup menu of the speedometer functions. |
| Briefly press the button . | Next display mode |
| Press the button for 2–3 seconds. | No function |
| Briefly press the button . | No function |

7.2.9 Setup menu

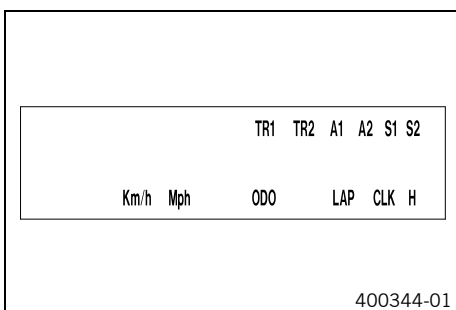

400344-01

Condition

- The motorcycle is stationary.
- Repeatedly press the button briefly until **H** appears at the bottom right of the display.
- Press the button for 2–3 seconds.

The Setup menu displays the active functions.

Info

Repeatedly press the button briefly until the desired function is opened.
If no button is pressed for 20 seconds, the settings are automatically stored.

| | |
|------------------------------------|---|
| Briefly press the button . | Activates the flashing display and changes to the next display |
| Press the button for 2–3 seconds. | No function |
| Briefly press the button . | Deactivates the flashing display and changes to the next display |
| Press the button for 2–3 seconds. | No function |
| Wait 3–5 seconds | Changes to the next display without changes |
| Wait 10–12 seconds | Setup menu starts, stores the settings, and changes to H or ODO . |

7.2.10 Setting the unit of measurement

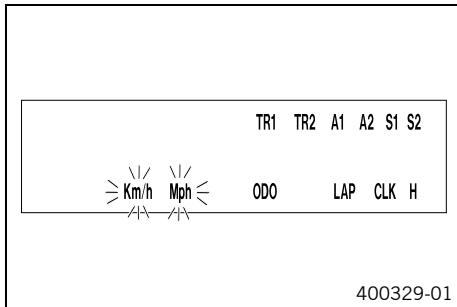

Condition

- The motorcycle is stationary.
- Repeatedly press the button briefly until **H** appears at the bottom right of the display.
- Press the button for 2–3 seconds.
- Repeatedly press the button briefly until **Km/h/Mph** flashes.

In measurement unit mode, you can change the unit of measurement.

Info

If no button is pressed for 5 seconds, the settings are automatically stored.

| | |
|------------------------------------|---|
| Briefly press the button . | Starts selection, activates Km/h display |
| Press the button for 2–3 seconds. | No function |
| Briefly press the button . | Activates Mph display |
| Press the button for 2–3 seconds. | No function |
| Wait 3–5 seconds | Changes to the next display, changes from selection to the Setup menu |
| Wait 10–12 seconds | Saves and closes the Setup menu |

7.2.11 Display mode SPEED/CLK (time)

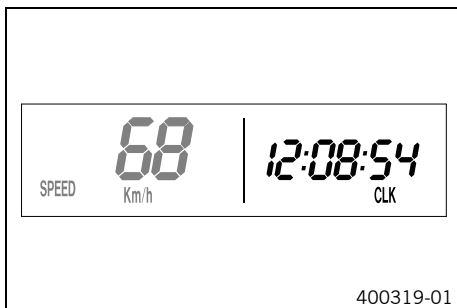

- Repeatedly press the button briefly until **CLK** appears at the bottom right of the display.

The time is shown in display mode **CLK**.

| | |
|------------------------------------|---|
| Press the button for 2–3 seconds. | The display changes to the Setup menu of the clock. |
| Briefly press the button . | Next display mode |
| Press the button for 2–3 seconds. | No function |
| Briefly press the button . | No function |

7.2.12 Setting the clock



Condition

- The motorcycle is stationary.
- Repeatedly press the button briefly until **CLK** appears at the bottom right of the display.
- Press the button for 2–3 seconds.

| | |
|------------------------------------|---------------------------|
| Press the button for 2–3 seconds. | Increases the value |
| Briefly press the button . | Increases the value |
| Press the button for 2–3 seconds. | Reduces the value |
| Briefly press the button . | Reduces the value |
| Wait 3–5 seconds | Changes to the next value |
| Wait 10–12 seconds | Closes the SETUP menu |

7.2.13 Display mode SPEED/LAP (lap time)

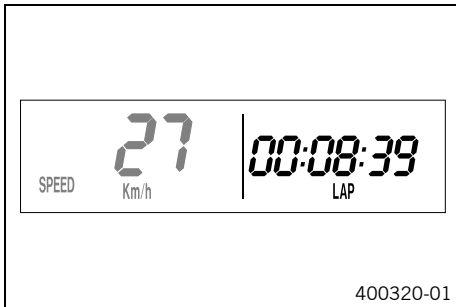

- Repeatedly press the button **+** briefly until **LAP** appears at the bottom right of the display.

In the **LAP** display mode, up to 10 lap times can be timed with the stop watch.

i Info
If the lap time continues running after the button **+** is pressed, 9 memory locations are occupied.
Lap 10 must be timed using the button **+**.

| | |
|--|---|
| Press the button + for 2–3 seconds. | The stop watch and the lap time are reset. |
| Briefly press the button + . | Next display mode |
| Press the button + for 2–3 seconds. | Stops the clock. |
| Briefly press the button + . | Starts the stop watch or stop the current lap time measurement, stores it and the stop watch starts the next lap. |

7.2.14 Viewing the lap time

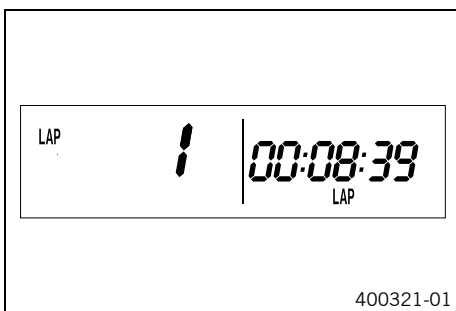

Condition

- The motorcycle is stationary.
- Repeatedly press the button **+** briefly until **LAP** appears at the bottom right of the display.
- Briefly press the button **+**.

| | |
|--|--|
| Press the button + for 2–3 seconds. | The stop watch and the lap time are reset. |
| Briefly press the button + . | Select a lap from 1–10 |
| Press the button + for 2–3 seconds. | No function |
| Briefly press the button + . | View the next lap time. |

7.2.15 Display mode SPEED/ODO (odometer)



- Repeatedly press the button **+** briefly until **ODO** appears at the bottom right of the display.

The total traveled distance is shown in display mode **ODO**.

| | |
|--|-------------------|
| Press the button + for 2–3 seconds. | No function |
| Briefly press the button + . | Next display mode |
| Press the button + for 2–3 seconds. | No function |
| Briefly press the button + . | No function |

7.2.16 Display mode SPEED/TR1 (trip master 1)

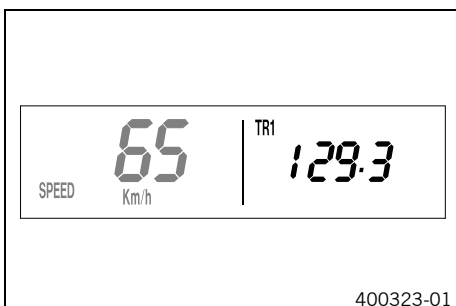

- Repeatedly press the button **+** briefly until **TR1** appears at the top right of the display.

TR1 (trip master 1) runs constantly and counts up to 999.9.

You can use it to measure trips or the distance between refueling stops.

TR1 is coupled with **A1** (average speed 1) and **S1** (stop watch 1).

i Info
If 999.9 is exceeded, the values of **TR1**, **A1** and **S1** are automatically reset to 0.0.

| | |
|---|--|
| Press the button \oplus for 2–3 seconds. | Displays of TR1 , A1 and S1 are reset to 0,0. |
| Briefly press the button \oplus . | Next display mode |
| Press the button \ominus for 2–3 seconds. | No function |
| Briefly press the button \ominus . | No function |

7.2.17 Display mode SPEED/TR2 (trip master 2)

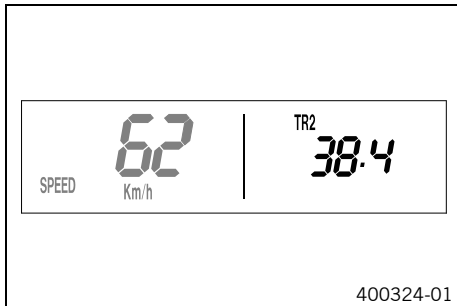

- Repeatedly press the button \oplus briefly until **TR2** appears at the top right of the display.

TR2 (trip master 2) runs constantly and counts up to 999.9.

| | |
|---|--|
| Press the button \oplus for 2–3 seconds. | Clears the values TR2 and A2 . |
| Briefly press the button \oplus . | Next display mode |
| Press the button \ominus for 2–3 seconds. | Reduces value of TR2 . |
| Briefly press the button \ominus . | Reduces value of TR2 . |

7.2.18 Setting TR2 (trip master 2)

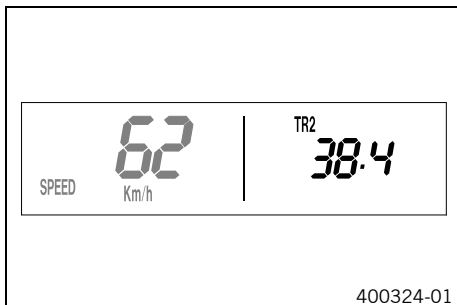

Condition

- The motorcycle is stationary.
- Repeatedly press the button \oplus briefly until **TR2** appears at the top right of the display.
- Press the button \ominus for 2–3 seconds until **TR2** flashes.

The displayed value can be set manually with the button \oplus and the button \ominus . This is a very practical function when riding using the road book.

i Info

The **TR2** value can also be corrected manually during the journey with the button \oplus and the button \ominus .
If 999.9 is exceeded, the value of **TR2** is automatically reset to 0.0.

| | |
|---|---------------------------------|
| Press the button \oplus for 2–3 seconds. | Increases value of TR2 . |
| Briefly press the button \oplus . | Increases value of TR2 . |
| Press the button \ominus for 2–3 seconds. | Reduces value of TR2 . |
| Briefly press the button \ominus . | Reduces value of TR2 . |
| Wait 10–12 seconds | Saves and closes the Setup menu |

7.2.19 Display mode SPEED/A1 (average speed 1)

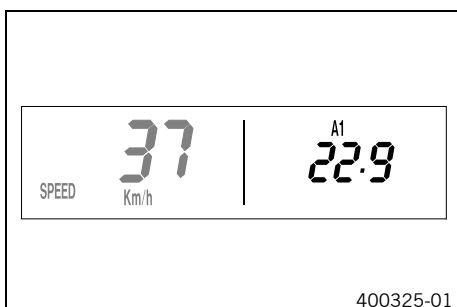



- Repeatedly press the button \oplus briefly until **A1** appears at the top right of the display.

A1 (average speed 1) shows the average speed calculated using **TR1** (trip master 1) and **S1** (stop watch 1).

The calculation of this value is activated by the first impulse of the wheel speed sensor and ends 3 seconds after the last impulse.

| | |
|--|--|
| Press the button \oplus for 2–3 seconds. | Displays of TR1 , A1 and S1 are reset to 0,0. |
| Briefly press the button \oplus . | Next display mode |

| | |
|---|-------------|
| Press the button  for 2–3 seconds. | No function |
| Briefly press the button  . | No function |





7.2.20 Display mode SPEED/A2 (average speed 2)



- Repeatedly press the button  briefly until **A2** appears at the top right of the display.

A2 (average speed 2) shows the average speed on the basis of the current speed if the stop watch **S2** (stop watch 2) is running.

i Info
The displayed value can differ from the actual average speed if **S2** was not stopped after the ride.

| | |
|---|-------------------|
| Briefly press the button  . | Next display mode |
| Press the button  for 2–3 seconds. | No function |
| Press the button  for 2–3 seconds. | No function |
| Briefly press the button  . | No function |



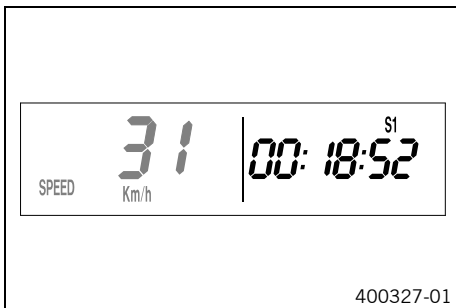

7.2.21 Display mode SPEED/S1 (stop watch 1)



- Repeatedly press the button  briefly until **S1** appears at the top right of the display.

S1 (Stop watch 1) shows the riding time based on **TR1** and continues running as soon as an impulse arrives from the wheel speed sensor.

The calculation of this value starts with the first impulse from the wheel speed sensor and ends 3 seconds after the last impulse.

| | |
|---|--|
| Press the button  for 2–3 seconds. | Displays of TR1 , A1 and S1 are reset to 0,0. |
| Briefly press the button  . | Next display mode |
| Press the button  for 2–3 seconds. | No function |
| Briefly press the button  . | No function |





7.2.22 Display mode SPEED/S2 (stop watch 2)



- Repeatedly press the button  briefly until **S2** appears at the top right of the display.

S2 (Stop watch 2) is a manual stop watch.

If **S2** is running in the background, the display **S2** flashes on the speedometer.

| | |
|---|---|
| Press the button  for 2–3 seconds. | The displays of S2 and A2 are set to 0,0. |
| Briefly press the button  . | Next display mode |
| Press the button  for 2–3 seconds. | No function |
| Briefly press the button  . | Starts or stops S2 . |

7.2.23 Table of functions

| Display | Press the button + for 2–3 seconds. | Briefly press the button + . | Press the button = for 2–3 seconds. | Briefly press the button = . | Wait 3–5 seconds | Wait 10–12 seconds |
|--|---|--|--|---|---|---|
| Display mode SPEED/H (service hours) | The display changes to the Setup menu of the speedometer functions. | Next display mode | No function | No function | | |
| Setup menu | No function | Activates the flashing display and changes to the next display | No function | Deactivates the flashing display and changes to the next display | Changes to the next display without changes | Setup menu starts, stores the settings, and changes to H or ODO . |
| Setting the unit of measurement | No function | Starts selection, activates Km/h display | No function | Activates Mph display | Changes to the next display, changes from selection to the Setup menu | Saves and closes the Setup menu |
| Display mode SPEED/CLK (time) | The display changes to the Setup menu of the clock. | Next display mode | No function | No function | | |
| Setting the clock | Increases the value | Increases the value | Reduces the value | Reduces the value | Changes to the next value | Closes the SETUP menu |
| Display mode SPEED/LAP (lap time) | The stop watch and the lap time are reset. | Next display mode | Stops the clock. | Starts the stop watch or stop the current lap time measurement, stores it and the stop watch starts the next lap. | | |
| Viewing the lap time | The stop watch and the lap time are reset. | Select a lap from 1–10 | No function | View the next lap time. | | |
| Display mode SPEED/ODO (odometer) | No function | Next display mode | No function | No function | | |
| Display mode SPEED/TR1 (trip master 1) | Displays of TR1 , A1 and S1 are reset to 0,0. | Next display mode | No function | No function | | |
| Display mode SPEED/TR2 (trip master 2) | Clears the values TR2 and A2 . | Next display mode | Reduces value of TR2 . | Reduces value of TR2 . | | |
| Setting TR2 (trip master 2) | Increases value of TR2 . | Increases value of TR2 . | Reduces value of TR2 . | Reduces value of TR2 . | | Saves and closes the Setup menu |
| Display mode SPEED/A1 (average speed 1) | Displays of TR1 , A1 and S1 are reset to 0,0. | Next display mode | No function | No function | | |
| Display mode SPEED/A2 (average speed 2) | No function | Next display mode | No function | No function | | |
| Display mode SPEED/S1 (stop watch 1) | Displays of TR1 , A1 and S1 are reset to 0,0. | Next display mode | No function | No function | | |
| Display mode SPEED/S2 (stop watch 2) | The displays of S2 and A2 are set to 0,0. | Next display mode | No function | Starts or stops S2 . | | |

7.2.24 Table of conditions and menu activation

| Display | The motorcycle is stationary. | Menu can be activated |
|--|-------------------------------|-----------------------|
| Display mode SPEED/H (service hours) | • | |
| Setup menu | • | |
| Setting the unit of measurement | • | |
| Setting the clock | • | |
| Display mode SPEED/LAP (lap time) | | • |
| Viewing the lap time | • | |
| Display mode SPEED/TR1 (trip master 1) | | • |
| Display mode SPEED/TR2 (trip master 2) | | • |
| Setting TR2 (trip master 2) | • | |
| Display mode SPEED/A1 (average speed 1) | | • |
| Display mode SPEED/A2 (average speed 2) | | • |
| Display mode SPEED/S1 (stop watch 1) | | • |
| Display mode SPEED/S2 (stop watch 2) | | • |

8.1 Advice on first use

**Danger****Danger of accidents** Danger arising from the rider's judgement being impaired.

- Do not operate the vehicle while under the influence of alcohol, drugs and certain medications or physically or mentally impaired.

**Warning****Risk of injury** Missing or poor protective clothing presents an increased safety risk.

- Wear protective clothing (helmet, boots, gloves, pants and jacket with protectors) every time you ride the vehicle. Always wear protective clothing that is in good condition and meets the legal requirements.

**Warning****Danger of crashing** Poor vehicle handling due to different tire tread patterns on front and rear wheels.

- The front and rear wheels must be fitted with tires with similar tread patterns to prevent loss of control over the vehicle.

**Warning****Danger of accidents** Critical riding behavior due to inappropriate riding.

- Adapt your riding speed to the road conditions and your riding ability.

**Warning****Danger of accidents** Accident risk caused by presence of a passenger.

- Your vehicle is not designed to carry passengers. Do not ride with a passenger.

**Warning****Danger of accidents** Failure of brake system.

- If the foot brake lever is not released, the brake linings drag continuously. The rear brake may fail due to overheating. Take your foot off the foot brake lever when you are not braking.

**Warning****Danger of accidents** Unstable riding behavior.

- Do not exceed the maximum permissible weight and axle loads.

**Warning****Risk of misappropriation** Usage by unauthorized persons.

- Never leave the vehicle while the engine is running. Secure the vehicle against use by unauthorized persons.

**Info**

When using your motorcycle, remember that others may feel disturbed by excessive noise.

- Make sure that the pre-delivery inspection work has been carried out by an authorized KTM workshop.
 - ✓ You receive a delivery certificate and the service record at vehicle handover.
- Before your first trip, read the entire operating instructions carefully.
- Get to know the controls.
- Adjust the basic position of the clutch lever. (☛ p. 78)

(All EXC-F models)

- Adjust the free travel of the hand brake lever. (☛ p. 81)

(XCF-W)

- Adjust the basic position of the hand brake lever. (☛ p. 81)
- Adjust the basic position of the foot brake lever. ☛ (☛ p. 85)
- Adjust the basic position of the shift lever. ☛ (☛ p. 107)
- Get used to handling the motorcycle on a suitable piece of land before making a longer trip.

**Info**

Offroad, you should be accompanied by another person on another machine so that you can help each other.

- Try also to ride as slowly as possible and in a standing position to get a better feeling for the vehicle.
- Do not make any offroad trips that over-stress your ability and experience.

- Hold the handlebar firmly with both hands and keep your feet on the footrests when riding.
- If you carry any baggage, make sure it is fixed firmly as close as possible to the center of the vehicle and ensure even weight distribution between the front and rear wheels.



Info

Motorcycles react sensitively to any changes of weight distribution.

- Do not exceed the overall maximum permitted weight and the axle loads.

Guideline

| | |
|-------------------------------------|------------------|
| Maximum permissible overall weight | 335 kg (739 lb.) |
| Maximum permissible front axle load | 145 kg (320 lb.) |
| Maximum permissible rear axle load | 190 kg (419 lb.) |

- Run in the engine. (☛ p. 39)

8.2 Running-in the engine

- During the running-in phase, do not exceed the specified engine speed and engine performance.

Guideline

| | |
|------------------------------------|-----------|
| Maximum engine speed | |
| During the first operating hour | 7,000 rpm |
| Maximum engine performance | |
| During the first 3 operating hours | ≤ 75 % |

- Avoid fully opening the throttle!

8.3 Preparing the vehicle for difficult riding conditions



Info

Use of the vehicle under difficult conditions, such as on sand or on wet and muddy surfaces, can lead to considerably more rapid wear of components such as the drive train, brake system, or suspension components. For this reason, it may be necessary to inspect or replace parts before the next scheduled service.

- KTM recommends that you use the specified engine oil for difficult riding conditions and to increase performance.

| |
|--|
| Engine oil (SAE 10W/60) (00062010035) (☛ p. 126) |
|--|

- Clean the air filter and air filter box. ☛ (☛ p. 69)



Info

Check the air filter approx. every 30 minutes.

- Seal the air filter box. ☛ (☛ p. 70)
- Additionally secure the rubber grip. (☛ p. 78)
- Check the electrical connector for humidity and corrosion and to ensure it is firmly seated.
 - » If humidity, corrosion or damage is found:
 - Clean and dry the connector, or change it if necessary.

Difficult riding conditions are:

- Rides on dry sand. (☛ p. 40)
- Rides on wet sand. (☛ p. 40)
- Rides on wet and muddy surfaces. (☛ p. 41)
- Rides at high temperature and slow speed. (☛ p. 41)
- Rides at low low temperature or in snow. (☛ p. 41)

8.4 Preparing for rides on dry sand



- Fit a dust cover on the air filter.

Dust protection device for air filter (77206920000)



Info

See the **KTM PowerParts** fitting instructions.



- Fit a sand cover on the air filter.

Sand protection device for air filter (59006022000)



Info

See the **KTM PowerParts** fitting instructions.



- Clean the chain.

Chain cleaner (☛ p. 128)

- Fit the steel sprocket.



Tip

Do not grease the chain.

- Clean the radiator fins.
- Straighten bent radiator fins carefully.

8.5 Preparing for rides on wet sand



- Fit a rain cover on the air filter.

Waterproofing device for air filter (77206921000)



Info

See the **KTM PowerParts** fitting instructions.



- Clean the chain.

Chain cleaner (☛ p. 128)

- Fit the steel sprocket.



Tip

Do not grease the chain.

- Clean the radiator fins.
- Straighten bent radiator fins carefully.

8.6 Preparing for rides on wet and muddy surfaces



- Fit a waterproofing device on the air filter.

Waterproofing device for air filter (77206921000)



Info

See the **KTM PowerParts** fitting instructions.



- Fit the steel sprocket.
- Clean the motorcycle. (☛ p. 112)
- Straighten bent radiator fins carefully.

8.7 Preparing for rides at high temperature and slow speed



- Adjust the secondary drive to the road conditions.



Info

The engine oil heats up quickly when the clutch is operated frequently due to an excessively high secondary drive.

- Clean the chain.

Chain cleaner (☛ p. 128)

- Clean the radiator fins.
- Straighten bent radiator fins carefully.
- Check the coolant level. (☛ p. 104)

8.8 Preparing for rides at low temperature or in snow



- Fit a waterproofing device on the air filter.

Waterproofing device for air filter (77206921000)



Info

See the **KTM PowerParts** fitting instructions.

9.1 Checks and maintenance work when preparing for use



Info

Before riding the vehicle, always check its condition and operating safety. The vehicle must be in perfect technical condition when used.

- Check the engine oil level. (☛ p. 108)
- Check the electrical system.
- Check the brake fluid level of the front brake. (☛ p. 82)
- Check the rear brake fluid level. (☛ p. 86)
- Check the front brake linings. (☛ p. 83)
- Check the rear brake linings. (☛ p. 87)
- Check that the brake system is functioning properly.
- Check the coolant level. (☛ p. 104)
- Check for chain dirt accumulation. (☛ p. 73)
- Check the chain, rear sprocket, engine sprocket and chain guide. (☛ p. 75)
- Check the chain tension. (☛ p. 74)
- Check the tire condition. (☛ p. 92)
- Check the tire air pressure. (☛ p. 93)
- Check the spoke tension. (☛ p. 93)
- Clean the dust boots of the fork legs. (☛ p. 56)
- Bleed fork legs. (☛ p. 56)
- Check the air filter.
- Check the settings of all controls and ensure that they can be operated smoothly.
- Check all screws, nuts, and hose clamps regularly for tightness.
- Check the fuel supply.

9.2 Starting



Danger

Danger of poisoning Exhaust gases are toxic and inhaling them may result in unconsciousness and/or death.

- When running the engine, always make sure there is sufficient ventilation, and do not start or run the engine in an enclosed space without an effective exhaust extraction system.

Note

Engine failure High engine speeds in cold engines have a negative effect on the service life of the engine.

- Always warm up the engine at low engine speeds.

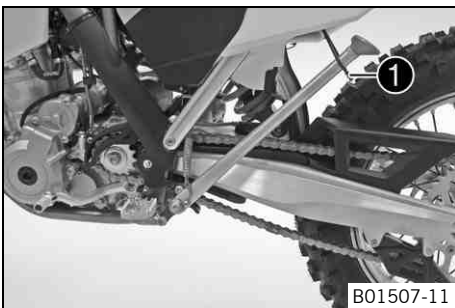

- Raise the motorcycle off of the stand and secure the stand with the rubber band ❶.
- Shift transmission to neutral.

(EXC-F AUS)

- Turn the emergency OFF switch to the position ☐.

Condition

Ambient temperature: < 20 °C (< 68 °F)

- Pull the idle speed adjusting screw all the way out.

- Press the electric starter button or press the kick starter robustly through its full range.



Info

Press the electric starter button for at most 5 seconds. Wait for a least 5 seconds before trying again.

Warning lamp FI lights up briefly as a functional control when starting.

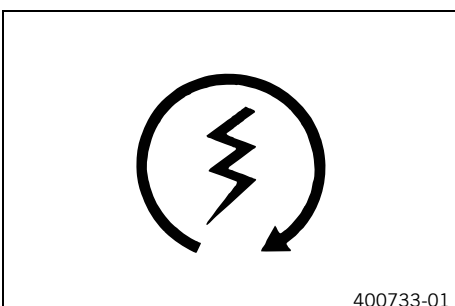

9.3 Starting off

Info

If your bike has lights, switch them on before riding. You will then be seen earlier by other motorists. When you are riding, the side stand must be folded up and secured with the rubber band.

- Pull the clutch lever, engage 1st gear, release the clutch lever slowly and simultaneously open the throttle carefully.

9.4 Shifting, riding

Warning

Danger of accidents If you change down at high engine speed, the rear wheel can lock up.

- Do not change into a low gear at high engine speed. The engine races and the rear wheel can lock up.

Info

If you hear unusual noises while riding, stop immediately, switch off the engine, and contact an authorized KTM workshop. First gear is used for starting off or for steep inclines.

- When conditions allow (incline, road situation, etc.), you can shift into a higher gear. To do so, release the throttle while simultaneously pulling the clutch lever, shift into the next gear, release the clutch, and open the throttle.
- After reaching maximum speed by fully opening the throttle grip, turn the throttle back so it is $\frac{3}{4}$ open. This will barely reduce the speed but fuel consumption will be considerably lower.
- Always open the throttle only as much as the engine can handle – abrupt throttle opening increases fuel consumption.
- To shift down, brake and close the throttle at the same time.
- Pull the clutch lever and shift into a lower gear, release the clutch lever slowly, and open the throttle or shift again.
- Switch off the engine if you expect to be standing for a long time.

Guideline

| |
|--------------|
| ≥ 2 min |
|--------------|

- Avoid frequent and longer slipping of the clutch. This heats the engine oil, the engine, and the cooling system.
- Ride with a lower engine speed instead of with a high engine speed and a slipping clutch.

9.5 Braking

Warning

Danger of accidents If you brake too hard, the wheels can lock.

- Adapt your braking to the traffic situation and the road conditions.

Warning

Danger of accidents Reduced braking efficiency caused by spongy pressure point of front or rear brake.

- Check the brake system and do not continue riding. (Your authorized KTM workshop will be glad to help.)

Warning

Danger of accidents Reduced braking efficiency due to a wet or dirty brake system.

- Clean or dry a dirty or wet brake system by riding and braking gently.

- On sandy, wet or slippery surfaces, use the rear brake.
- Braking should always be completed before you go into a bend. Change down to a lower gear appropriate to your road speed.
- Make use of the braking effect of the engine when driving down long downhill stretches. To do so, shift back one or two gears, but do not overrev the engine. You will need to apply the brakes far less often and the brake system will not overheat.

9.6 Stopping, parking



Warning

Risk of misappropriation Usage by unauthorized persons.

- Never leave the vehicle while the engine is running. Secure the vehicle against use by unauthorized persons.



Warning

Danger of burns Some vehicle components become very hot when the vehicle is operated.

- Do not touch hot components such as exhaust system, radiator, engine, shock absorber, and the brake system. Allow these components to cool down before starting work on them.

Note

Danger of damage The parked vehicle may roll away or fall over.

- Always place the vehicle on a firm and even surface.

Note

Fire hazard Some vehicle components become very hot when the vehicle is operated.

- Do not park the vehicle near flammable or explosive substances. Do not place objects on the vehicle while it is still warm from being run. Always let the vehicle cool first.

Note

Material damage Damage to or destruction of components due to excessive load.

- The side stand is only designed for the weight of the motorcycle. Do not sit on the motorcycle when it is resting on the side stand. The side stand or the frame may become damaged and the motorcycle may fall over.

- Brake the motorcycle.
- Shift transmission to neutral.

(All EXC-F models)

- Press and hold the kill switch  while the engine is idling until the engine stops.

(XCF-W)

- Press and hold the kill switch  while the engine is idling until the engine stops.
- Park the motorcycle on firm ground.

9.7 Transport

Note

Danger of damage The parked vehicle may roll away or fall over.

- Always place the vehicle on a firm and even surface.

Note

Fire hazard Some vehicle components become very hot when the vehicle is operated.

- Do not park the vehicle near flammable or explosive substances. Do not place objects on the vehicle while it is still warm from being run. Always let the vehicle cool first.

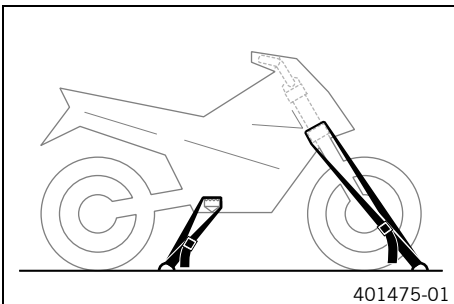

- Switch off the engine.
- Use tension belts or other suitable devices to secure the motorcycle against accidents or falling over.

9.8 Refueling



Danger

Fire hazard Fuel is highly flammable.

- Never refuel the vehicle near open flames or burning cigarettes, and always switch off the engine first. Be careful that no fuel is spilt, especially on hot vehicle components. Clean up spilt fuel immediately.
- The fuel in the fuel tank expands when warm and may emerge if overfilled. Follow the instructions on refueling.



Warning

Danger of poisoning Fuel is poisonous and a health hazard.

- Fuel must not come into contact with the skin, eyes, or clothing. Do not breathe in the fuel vapors. If contact occurs with the eyes, rinse with water immediately and contact a physician. Immediately clean contaminated areas on the skin with soap and water. If fuel is swallowed, contact a physician immediately. Change clothing that is contaminated with fuel.

Note

Material damage Premature clogging of the fuel filter.

- In some countries and regions, the available fuel quality and cleanliness may not be sufficient. This will result in problems with the fuel system. (Your authorized KTM workshop will be glad to help.)
- Only refuel with clean fuel that meets the specified standards.



Warning

Environmental hazard Improper handling of fuel is a danger to the environment.

- Do not allow fuel to get into the ground water, the ground, or the sewage system.

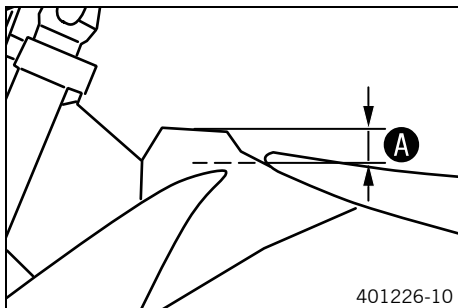

- Switch off engine.
- Open the filler cap. (☛ p. 17)
- Fill the fuel tank with fuel up to measurement **A**.

Guideline

| | | |
|--|---------------------|--|
| Measurement of A | 35 mm (1.38 in) | |
| Total fuel tank capacity, approx. (All EXC-F models) | 9 l (2.4 US gal) | Super unleaded (ROZ 95/RON 95/PON 91) (☛ p. 127) |
| Total fuel tank capacity, approx. (XCF-W) | 8.5 l (2.25 US gal) | Super unleaded (ROZ 95/RON 95/PON 91) (☛ p. 127) |

- Close the filler cap. (☛ p. 17)

10.1 Service schedule

| | Every 30 operating hours/after every race | Every 15 operating hours | Once after 1 operating hour |
|---|---|--------------------------|-----------------------------|
| Read out the fault memory using the KTM diagnostics tool. 🛠️ | ○ | ● | ● |
| Check that the electrical equipment is functioning properly. | ○ | ● | ● |
| Check and charge the battery. 🛠️ | | ● | ● |
| Check the front brake linings. (🔧 p. 83) | | ● | ● |
| Check the rear brake linings. (🔧 p. 87) | | ● | ● |
| Check the brake discs. (🔧 p. 82) | | ● | ● |
| Check the brake lines for damage and leakage. | | ● | ● |
| Check the rear brake fluid level. (🔧 p. 86) | | ● | ● |
| Check the free travel of the foot brake lever. (🔧 p. 85) | | ● | ● |
| Check the frame and swingarm. 🛠️ | | ● | ● |
| Check the swingarm bearing. 🛠️ | | | ● |
| Check the heim joints at the top and bottom of the shock absorber. 🛠️ | | ● | ● |
| Check the tire condition. (🔧 p. 92) | ○ | ● | ● |
| Check the tire air pressure. (🔧 p. 93) | ○ | ● | ● |
| Check the wheel bearing for play. 🛠️ | | ● | ● |
| Check the wheel hubs. 🛠️ | | ● | ● |
| Check the rim run-out. 🛠️ | ○ | ● | ● |
| Check the spoke tension. (🔧 p. 93) | ○ | ● | ● |
| Check the chain, rear sprocket, engine sprocket and chain guide. (🔧 p. 75) | | ● | ● |
| Check the chain tension. (🔧 p. 74) | ○ | ● | ● |
| Grease all moving parts (e.g., side stand, hand lever, chain, ...) and check for smooth operation. 🛠️ | | ● | ● |
| Check/correct the fluid level of the hydraulic clutch. (🔧 p. 79) | | ● | ● |
| Check the brake fluid level of the front brake. (🔧 p. 82) | | ● | ● |
| Check the free travel of the hand brake lever. (🔧 p. 81) | | ● | ● |
| Check the steering head bearing play. (🔧 p. 64) | ○ | ● | ● |
| Check the valve clearance. 🛠️ | ○ | | ● |
| Check the clutch. 🛠️ | | | ● |
| Change the shaft seal rings of the water pump. 🛠️ | | | ● |
| Change the engine oil and oil filter, clean the oil screen. 🛠️ (🔧 p. 109) | ○ | ● | ● |
| Check all hoses (e. g., fuel, cooling, bleeding, drainage) and sleeves for cracking, leaks, and incorrect routing. 🛠️ | ○ | ● | ● |
| Check the antifreeze and coolant level. (🔧 p. 103) | ○ | ● | ● |
| Check the cables for damage and routing without sharp bends. 🛠️ | | ● | ● |
| Check that the cables are undamaged, routed without sharp bends and set correctly. | ○ | ● | ● |
| Clean the air filter and air filter box. 🛠️ | | ● | ● |
| Change the glass fiber yarn filling of the main silencer. 🛠️ (🔧 p. 70) | | | ● |
| Check the screws and nuts for tightness. 🛠️ | ○ | ● | ● |
| Check the headlight setting. (🔧 p. 100) | ○ | ● | ● |
| Change the fuel screen. 🛠️ (🔧 p. 108) | ○ | ● | ● |
| Check the fuel pressure. 🛠️ | | ● | ● |
| Adjust the idle speed. 🛠️ (🔧 p. 107) | ○ | ● | ● |
| Check that the radiator fan is functioning properly. 🛠️ (EXC-F SIX DAYS, XCF-W) | ○ | ● | ● |
| Final check: Check the vehicle for roadworthiness and take a test ride. | ○ | ● | ● |
| Read out the fault memory using the KTM diagnostics tool after a test ride. 🛠️ | ○ | ● | ● |
| Make the service entry in KTM DEALER.NET and in the service record. 🛠️ | ○ | ● | ● |

○ One-time interval

- Periodic interval

10.2 Service work (as additional order)

| | Annually | | |
|--|--|--------------------------|-------------------------------|
| | Every 135 operating hours/every 70 operating hours when used for motorsports | Every 45 operating hours | Once after 15 operating hours |
| Change the front brake fluid. 🛠️ | | | • |
| Change the rear brake fluid. 🛠️ | | | • |
| Change the hydraulic clutch fluid. 🛠️ (🔧 p. 79) | | | • |
| Grease the steering head bearing. 🛠️ (🔧 p. 66) | | | • |
| Clean the spark arrestor. 🛠️ (XCF-W) | | | • |
| Perform a fork service. (EXC-F SIX DAYS) 🛠️ | ○ | • | • |
| Perform a fork service. (EXC-F EU, EXC-F AUS, XCF-W) 🛠️ | ○ | • | • |
| Service the shock absorber. 🛠️ | | • | • |
| Change the spark plug and spark plug connector. 🛠️ | | | • |
| Change the piston. 🛠️ | | | • |
| Check/measure the cylinder. 🛠️ | | | • |
| Check the cylinder head. 🛠️ | | | • |
| Change the valves, valve springs and valve spring seats. 🛠️ | | | • |
| Check the camshaft and cam lever. 🛠️ | | | • |
| Change the connecting rod, conrod bearing, and crank pin. 🛠️ | | | • |
| Check the transmission and shift mechanism. 🛠️ | | | • |
| Check the oil pressure regulator valve. 🛠️ | | | • |
| Change the suction pump. 🛠️ | | | • |
| Check the pressure pump and lubrication system. 🛠️ | | | • |
| Replace the timing chain. 🛠️ | | | • |
| Check the timing assembly. 🛠️ | | | • |
| Change all engine bearings. 🛠️ | | | • |

- One-time interval
- Periodic interval

11.1 Checking the basic suspension setting against the rider's weight

i Info When adjusting the basic suspension setting, first adjust the shock absorber and then the fork.

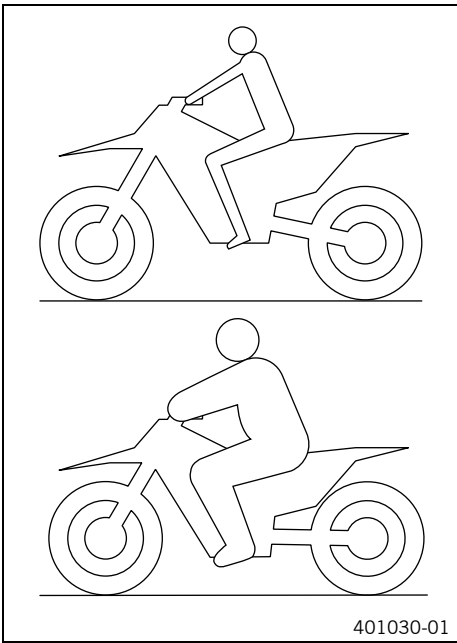

- For optimal motorcycle riding characteristics and to avoid damage to forks, shock absorbers, swingarm and frame, the basic settings of the suspension components must match the rider's weight.
- As delivered, KTM offroad motorcycles are adjusted for a standard rider weight (with full protective clothing).

Guideline

| | |
|-----------------------|------------------------------|
| Standard rider weight | 75... 85 kg (165... 187 lb.) |
|-----------------------|------------------------------|

- If the rider's weight is above or below the standard range, the basic setting of the suspension components must be adjusted accordingly.
- Small weight differences can be compensated by adjusting the spring preload, but in the case of large weight differences, the springs must be replaced.

11.2 Compression damping of shock absorber

The compression damping of the shock absorber is divided into two ranges: high-speed and low-speed. High-speed and low-speed refer to the compression speed of the rear wheel suspension and not to the vehicle speed. The high-speed setting, for example, has an effect on the landing after a jump: the rear wheel suspension compresses more quickly. The low-speed setting, for example, has an effect when riding over long ground swells: the rear wheel suspension compresses more slowly. These two ranges can be adjusted separately, although the transition between high-speed and low-speed is gradual. Thus, changes in the high-speed range affect the compression damping in the low-speed range and vice versa.

11.3 Adjusting the low-speed compression damping of the shock absorber

⚠ Caution
Danger of accidents Disassembly of pressurized parts can lead to injury.

- The shock absorber is filled with high density nitrogen. Adhere to the description provided. (Your authorized KTM workshop will be glad to help.)

i Info The low-speed setting can be seen during the slow to normal compression of the shock absorber.

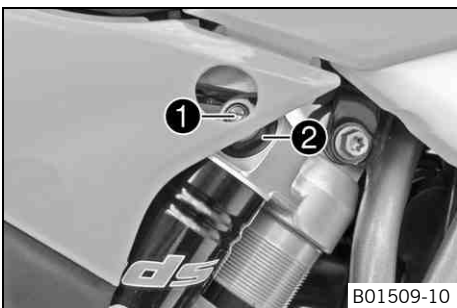

- Turn adjusting screw ❶ clockwise with a screwdriver up to the last perceptible click.

i Info
Do not loosen nut ❷!

- Turn back counterclockwise by the number of clicks corresponding to the shock absorber type.

Guideline

| Compression damping, low-speed | |
|--------------------------------|-----------|
| Comfort | 25 clicks |
| Standard | 20 clicks |
| Sport | 15 clicks |

i Info
Turn clockwise to increase damping; turn counterclockwise to reduce damping.

11.4 Adjusting the high-speed compression damping of the shock absorber

⚠ Caution
Danger of accidents Disassembly of pressurized parts can lead to injury.

- The shock absorber is filled with high density nitrogen. Adhere to the description provided. (Your authorized KTM workshop will be glad to help.)

i Info
The high-speed setting can be seen during the fast compression of the shock absorber.

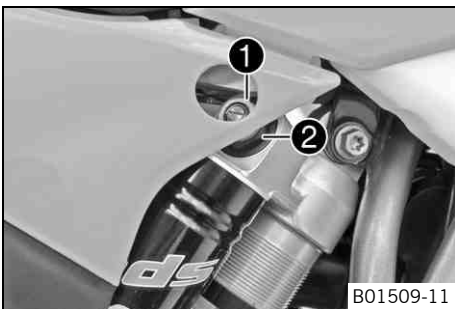

- Turn adjusting screw ❶ all the way clockwise with a socket wrench.

i Info
Do not loosen nut ❷!

- Turn back counterclockwise by the number of turns corresponding to the shock absorber type.

Guideline

| Compression damping, high-speed | |
|---------------------------------|------------|
| Comfort | 2 turns |
| Standard | 1.5 turns |
| Sport | 1.25 turns |

i Info
Turn clockwise to increase damping; turn counterclockwise to reduce damping.

11.5 Adjusting the rebound damping of the shock absorber

⚠ Caution
Danger of accidents Disassembly of pressurized parts can lead to injury.

- The shock absorber is filled with high density nitrogen. Adhere to the description provided. (Your authorized KTM workshop will be glad to help.)

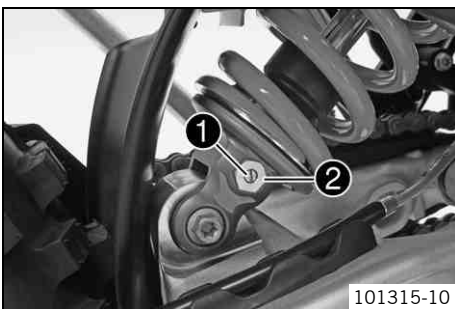

- Turn adjusting screw ❶ clockwise up to the last perceptible click.

i Info
Do not loosen nut ❷!

- Turn back counterclockwise by the number of clicks corresponding to the shock absorber type.

Guideline

| Rebound damping | |
|-----------------|-----------|
| Comfort | 28 clicks |
| Standard | 24 clicks |
| Sport | 22 clicks |

i Info
Turn clockwise to increase damping; turn counterclockwise to reduce damping.

11.6 Measuring rear wheel sag unloaded

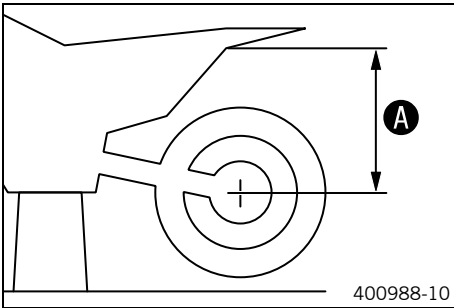

Preparatory work

- Raise the motorcycle with the lift stand. (☛ p. 56)

Main work

- Measure the distance – as vertically as possible – between the rear axle and a fixed point such as a mark on the side cover.
- Make note of the value as measurement **A**.

Finishing work

- Remove the motorcycle from the lift stand. (☛ p. 56)

11.7 Checking the static sag of the shock absorber

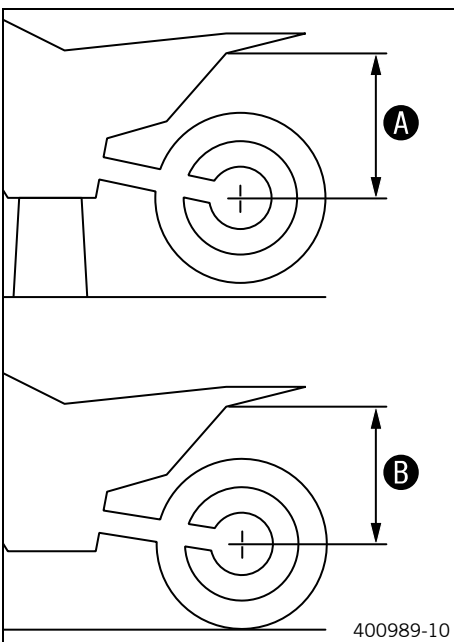

- Measure distance **A** of rear wheel unloaded. (☛ p. 50)
- Hold the motorcycle upright with the aid of an assistant.
- Measure the distance between the rear axle and the fixed point again.
- Note down the value as dimension **B**.

Info

The static sag is the difference between measurements **A** and **B**.

- Check the static sag.

| | |
|------------|------------------------------|
| Static sag | 33... 35 mm (1.3... 1.38 in) |
|------------|------------------------------|

- » If the static sag is less or more than the specified value:
 - Adjust the spring preload of the shock absorber. ☛ (☛ p. 51)

11.8 Checking the riding sag of the shock absorber

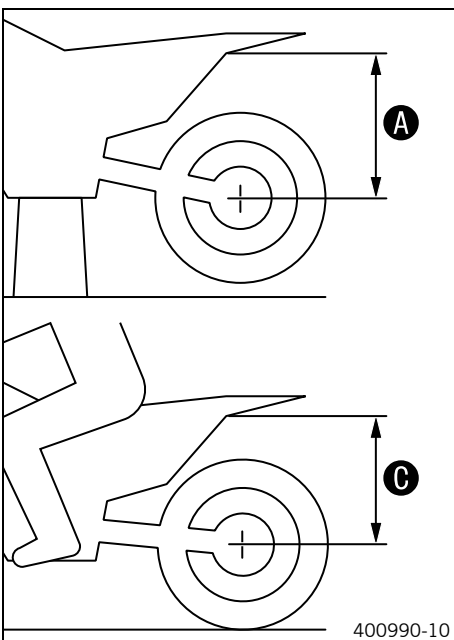

- Measure distance **A** of rear wheel unloaded. (☛ p. 50)
- With another person holding the motorcycle, the rider, wearing full protective clothing, sits on the seat in a normal sitting position (feet on footrests) and bounces up and down a few times.
 - ✓ The rear wheel suspension levels out.
- Another person now measures the distance between the rear axle and a fixed point.
- Note down the value as dimension **C**.

Info

The riding sag is the difference between measurements **A** and **C**.

- Check the riding sag.

| | |
|------------|---------------------------------|
| Riding sag | 105... 115 mm (4.13... 4.53 in) |
|------------|---------------------------------|

- » If the riding sag differs from the specified measurement:
 - Adjust the riding sag. ☛ (☛ p. 51)

11.9 Adjusting the spring preload of the shock absorber 🛠️

- ⚠️ Caution**
Danger of accidents Disassembly of pressurized parts can lead to injury.
- The shock absorber is filled with high density nitrogen. Adhere to the description provided. (Your authorized KTM workshop will be glad to help.)

i Info
 Before changing the spring preload, make a note of the present setting, e.g., by measuring the length of the spring.

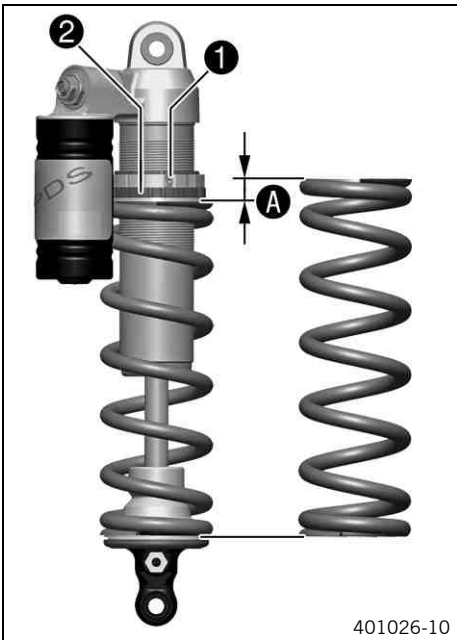

Preparatory work

- Raise the motorcycle with the lift stand. (🔧 p. 56)
- Remove shock absorber. 🛠️ (🔧 p. 67)
- After removing the shock absorber, clean it thoroughly.

Main work

- Loosen screw ❶.
- Turn adjusting ring ❷ until the spring is no longer under tension.

| |
|---------------------|
| Hook wrench (T106S) |
|---------------------|

- Measure the overall spring length while the spring is not under tension.
- Tighten the spring by turning adjusting ring ❷ to measurement ❸.

Guideline

| | |
|----------------|----------------|
| Spring preload | 8 mm (0.31 in) |
|----------------|----------------|

i Info

Depending on the static sag and/or the riding sag, it may be necessary to increase or decrease the spring preload.

- Tighten screw ❶.

Guideline

| | | |
|--------------------------------------|----|-------------------|
| Screw, shock absorber adjusting ring | M5 | 5 Nm (3.7 lbf ft) |
|--------------------------------------|----|-------------------|

Finishing work

- Install the shock absorber. 🛠️ (🔧 p. 67)
- Remove the motorcycle from the lift stand. (🔧 p. 56)

11.10 Adjusting the riding sag 🛠️

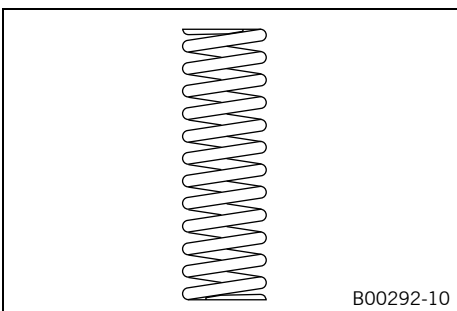

Preparatory work

- Raise the motorcycle with the lift stand. (🔧 p. 56)
- Remove shock absorber. 🛠️ (🔧 p. 67)
- After removing the shock absorber, clean it thoroughly.

Main work

- Choose and mount a suitable spring.

Guideline

| | |
|---|---------------------|
| Spring rate | |
| Weight of rider: 65... 75 kg (143... 165 lb.) | 66 N/mm (377 lb/in) |
| Weight of rider: 75... 85 kg (165... 187 lb.) | 69 N/mm (394 lb/in) |
| Weight of rider: 85... 95 kg (187... 209 lb.) | 72 N/mm (411 lb/in) |

i Info

The spring rate is shown on the outside of the spring. Smaller weight differences can be compensated by changing the spring preload.

Finishing work

- Install the shock absorber. (🔧 p. 67)
- Remove the motorcycle from the lift stand. (🔧 p. 56)
- Check the static sag of the shock absorber. (🔧 p. 50)
- Check the riding sag of the shock absorber. (🔧 p. 50)
- Adjust the rebound damping of the shock absorber. (🔧 p. 49)

11.11 Checking basic setting of fork

i Info

For various reasons, no exact riding sag can be determined for the forks.

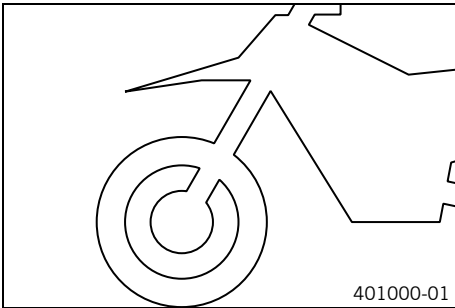

- As with the shock absorber, smaller differences in the rider's weight can be compensated by the spring preload.
- However, if the fork is often overloaded (hard end stop on compression), harder springs must be fit to avoid damage to the fork and frame.

11.12 Adjusting the compression damping of the fork

i Info

The hydraulic compression damping determines the fork suspension behavior.

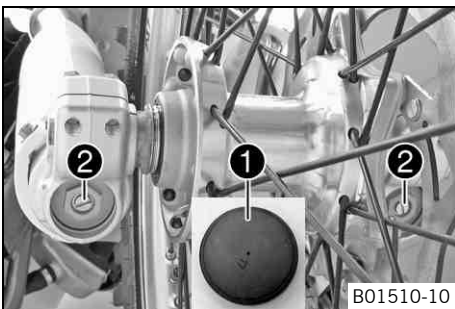

(EXC-F EU, EXC-F AUS, XCF-W)

- Remove protection caps ❶.
- Turn adjusting screws ❷ clockwise all the way.

i Info

Adjusting screws ❷ are located at the bottom end of the fork legs. Make the same adjustment on both fork legs.

- Turn back counterclockwise by the number of clicks corresponding to the fork type.

Guideline

| Compression damping | |
|---------------------|-----------|
| Comfort | 22 clicks |
| Standard | 20 clicks |
| Sport | 18 clicks |

i Info

Turn clockwise to increase damping; turn counterclockwise to reduce damping.

- Mount protection caps ❶.

(EXC-F SIX DAYS)

- Turn the white adjusting screw ❸ all the way clockwise.

i Info

Adjusting screw ❸ is located at the upper end of the left fork leg. The compression damping is located in the left fork leg **COMP** (white adjusting screw). The rebound damping is located in the right fork leg **REB** (red adjusting screw).

- Turn back counterclockwise by the number of clicks corresponding to the fork type.

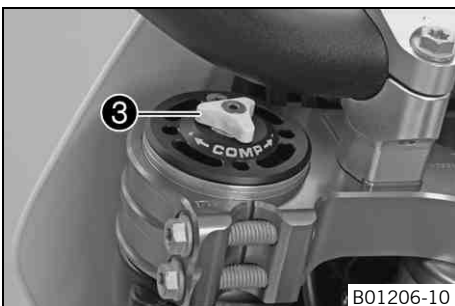

Guideline

| Compression damping | |
|---------------------|-----------|
| Comfort | 15 clicks |
| Standard | 13 clicks |
| Sport | 11 clicks |

i Info
Turn clockwise to increase damping; turn counterclockwise to reduce damping.

11.13 Adjusting the rebound damping of the fork

i Info
The hydraulic rebound damping determines the fork suspension behavior.

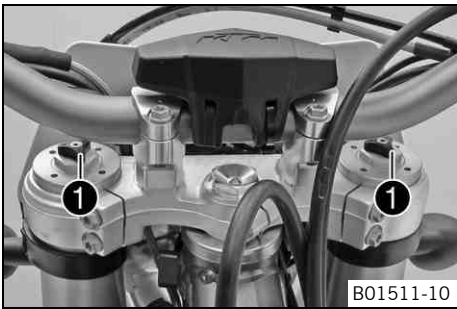

(EXC-F EU, EXC-F AUS, XCF-W)

- Turn adjusting screws ❶ clockwise all the way.

i Info
Adjusting screws ❶ are located at the top end of the fork legs. Make the same adjustment on both fork legs.

- Turn back counterclockwise by the number of clicks corresponding to the fork type.

Guideline

| Rebound damping | |
|-----------------|-----------|
| Comfort | 20 clicks |
| Standard | 18 clicks |
| Sport | 16 clicks |

i Info
Turn clockwise to increase damping; turn counterclockwise to reduce damping.

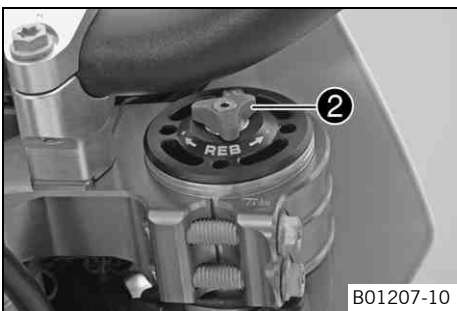

(EXC-F SIX DAYS)

- Turn the red adjusting screw ❷ all the way clockwise.

i Info
Adjusting screw ❷ is located at the upper end of the right fork leg. The rebound damping is located in the right fork leg **REB** (red adjusting screw). The compression damping is located in the left fork leg **COMP** (white adjusting screw).

- Turn back counterclockwise by the number of clicks corresponding to the fork type.

Guideline

| Rebound damping | |
|-----------------|-----------|
| Comfort | 15 clicks |
| Standard | 13 clicks |
| Sport | 11 clicks |

i Info
Turn clockwise to increase damping; turn counterclockwise to reduce damping.

11.14 Adjusting the spring preload of the fork (EXC-F EU, EXC-F AUS, XCF-W)

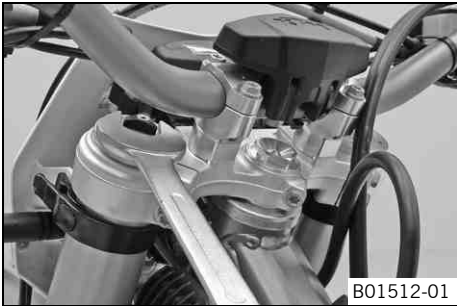

- Turn the adjusting screws counterclockwise all the way.

i Info
Make the same adjustment on both fork legs.

- Turn back clockwise by the number of turns corresponding to the fork type.

Guideline

| Spring preload - Preload Adjuster | |
|-----------------------------------|---------|
| Comfort | 1 turn |
| Standard | 2 turns |
| Sport | 2 turns |

i Info
Turn clockwise to increase spring preload; turn counterclockwise to reduce spring preload.

Adjusting the spring preload has no influence on the absorption setting of the rebound damping.

Basically, however, you should set the rebound damping higher with a higher spring preload.

11.15 Handlebar position

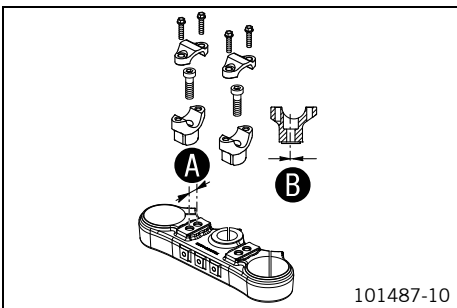

On the upper triple clamp, there are two holes at a distance of **A** to each other.

| | |
|------------------------|-----------------|
| Hole distance A | 15 mm (0.59 in) |
|------------------------|-----------------|

The holes on the handlebar supports are placed at a distance of **B** from the center.

| | |
|------------------------|-------------------|
| Hole distance B | 3.5 mm (0.138 in) |
|------------------------|-------------------|

The handlebar supports can be mounted in four different positions.

11.16 Adjusting handlebar position

Warning
Danger of accidents Handlebar breakage.

- If the handlebar is bent or straightened it will cause material fatigue, and the handlebar can break. Always replace handlebar.

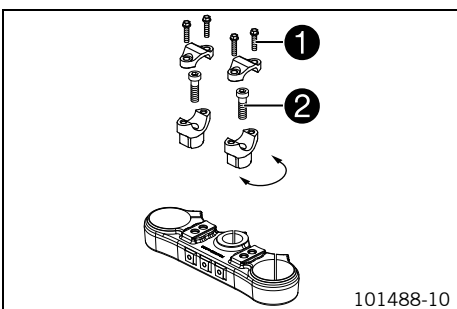

- Remove the four screws **1**. Remove the handlebar clamps. Remove the handlebar and lay it to one side.

i Info
Protect the motorcycle and its attachments from damage by covering them. Do not bend the cables and lines.

- Remove the two screws **2**. Remove the handlebar supports.
- Place the handlebar supports **2** in the required position. Fit and tighten the two screws **2**.

Guideline

| | | | |
|-------------------------|-----|------------------------|---------------|
| Screw, handlebar holder | M10 | 40 Nm (29.5 lbf ft) | Loctite® 243™ |
|-------------------------|-----|------------------------|---------------|

i Info
Position the left and right handlebar supports evenly.

- Position the handlebar.

i Info
Make sure cables and wiring are positioned correctly.

- Position the handlebar clamps. Fit and evenly tighten the four screws ❶.

Guideline

| | | |
|------------------------|----|------------------------|
| Screw, handlebar clamp | M8 | 20 Nm (14.8 lbf ft) |
|------------------------|----|------------------------|

**Info**

Make sure the gap width is even.

12.1 Raising the motorcycle with the lift stand

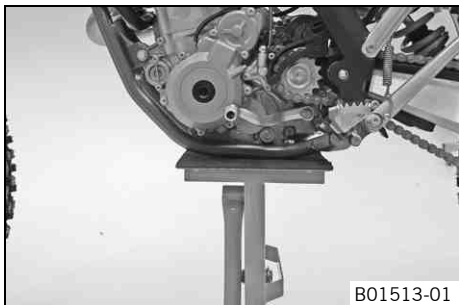

Note

Danger of damage The parked vehicle may roll away or fall over.

- Always place the vehicle on a firm and even surface.

- Raise the motorcycle at the frame underneath the engine.

Lift stand (54829055000)

- ✓ The wheels should no longer touch the ground.

- Secure the motorcycle against falling over.

12.2 Removing the motorcycle from the lift stand

Note

Danger of damage The parked vehicle may roll away or fall over.

- Always place the vehicle on a firm and even surface.

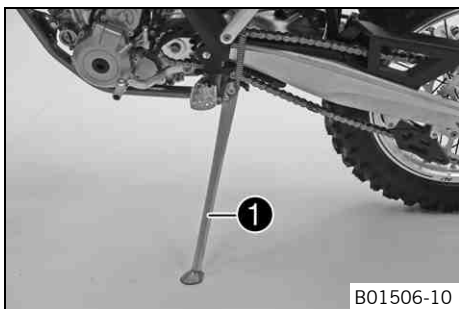

- Remove the motorcycle from the lift stand.
- Remove the lift stand.
- To park the motorcycle, press the side stand ❶ to the ground with your foot and lean the motorcycle on it.

i Info

When you are riding, the side stand must be folded up and secured with the rubber band.

12.3 Bleeding fork legs



Preparatory work

- Raise the motorcycle with the lift stand. (☛ p. 56)

Main work

- Release bleeder screws ❶.
- ✓ Any excess pressure escapes from the interior of the fork.
- Mount and tighten bleeder screws.

Finishing work

- Remove the motorcycle from the lift stand. (☛ p. 56)

12.4 Cleaning the dust boots of the fork legs

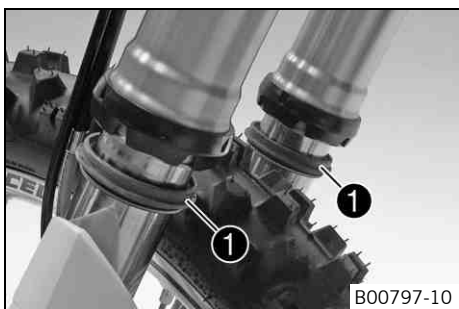

Preparatory work

- Raise the motorcycle with the lift stand. (☛ p. 56)
- Loosen the fork protector. (☛ p. 57)

Main work

- Push dust boot ❶ down on both fork leg.

i Info

The dust boots remove dust and coarse dirt particles from the inside fork tubes. Over time, dirt can penetrate behind the dust boots. If this dirt is not removed, the oil seals behind can start to leak.



Warning

Danger of accidents Reduced braking efficiency due to oil or grease on the brake discs.

- Always keep the brake discs free of oil and grease, and clean them with brake cleaner when necessary.

- Clean and lubricate the dust boot and inside fork tube on both fork legs.

Universal oil spray (☛ p. 129)

- Press the dust boots back into the installation position.
- Remove excess oil.

Finishing work

- Position the fork protector. (☛ p. 57)
- Remove the motorcycle from the lift stand. (☛ p. 56)

12.5 Loosening the fork protector

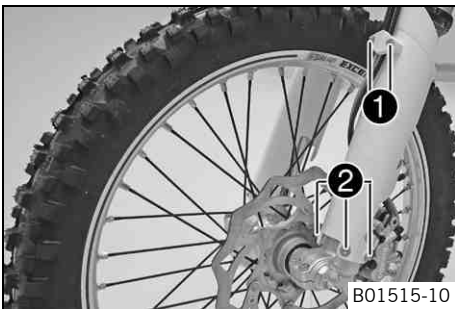

- Remove screws ❶ and remove the clamp.
- Remove screws ❷ on the left fork leg. Push the fork protector downwards.
- Remove the screws on the right fork leg. Push the fork protector downwards.

12.6 Positioning the fork protector

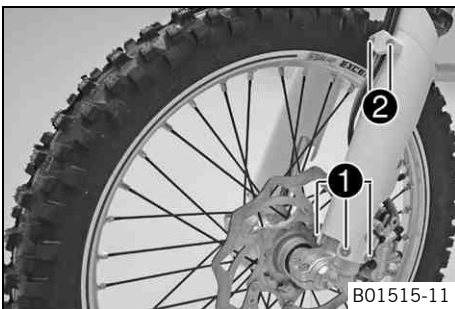

- Position the fork protector on the left fork leg. Mount and tighten screws ❶. Guideline

| | | |
|---------------------------|----|--------------------|
| Remaining screws, chassis | M6 | 10 Nm (7.4 lbf ft) |
|---------------------------|----|--------------------|

- Position the wiring harness.
- Position the brake line. Put the clamp on, and mount and tighten screws ❷.
- Position the fork protector on the right fork leg. Mount and tighten the screws. Guideline

| | | |
|---------------------------|----|--------------------|
| Remaining screws, chassis | M6 | 10 Nm (7.4 lbf ft) |
|---------------------------|----|--------------------|

12.7 Removing the fork legs ☞

Preparatory work

- Remove the headlight mask with the headlight. (☛ p. 98)
- Raise the motorcycle with the lift stand. (☛ p. 56)
- Remove the front wheel. ☞ (☛ p. 90)

Main work

- Remove screws ❶ and take off the clamp.
- Remove cable binder ❷.
- Remove screws ❸ and take off the brake caliper.
- Allow the brake caliper and brake line to hang tension-free to the side.

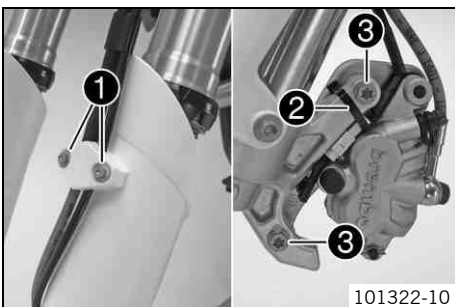

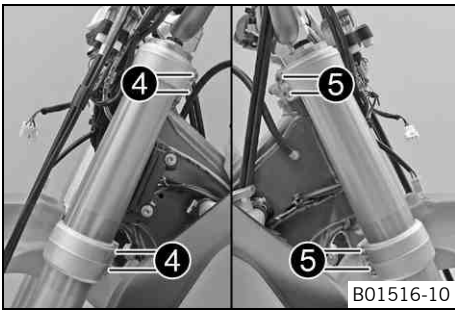

(EXC-F EU, EXC-F AUS, XCF-W)

- Release screws 4. Take out the left fork leg.
- Release screws 5. Take out the right fork leg.

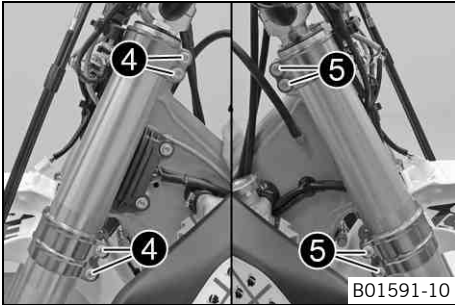

(EXC-F SIX DAYS)

- Release screws 4. Take out the left fork leg.
- Release screws 5. Take out the right fork leg.

12.8 Installing the fork legs



Main work

(EXC-F EU, EXC-F AUS, XCF-W)

- Position the fork legs.
- ✓ Position bleeder screws 1 toward the front.

i Info
Grooves are milled into the side of the upper end of the fork legs. The second milled groove (from the top) must be flush with the top edge of the upper triple clamp.

- Tighten screws 2.

Guideline

| | | |
|-------------------------|----|------------------------|
| Screw, top triple clamp | M8 | 20 Nm (14.8 lbf ft) |
|-------------------------|----|------------------------|

- Tighten screws 3.

Guideline

| | | |
|----------------------------|----|------------------------|
| Screw, bottom triple clamp | M8 | 15 Nm (11.1 lbf ft) |
|----------------------------|----|------------------------|

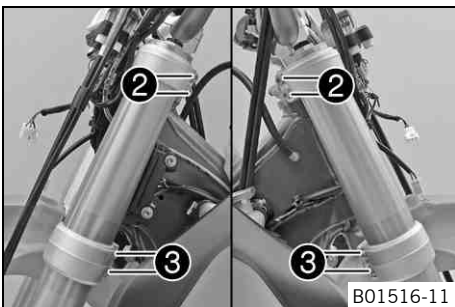

(EXC-F SIX DAYS)

- Position the fork legs.
- ✓ Position bleeder screws 1 toward the front.

i Info
The rebound damping is located in the right fork leg **REB** (red adjusting screw). The compression damping is located in the left fork leg **COMP** (white adjusting screw).
Grooves are milled into the side of the upper end of the fork legs. The second milled groove (from the top) must be flush with the top edge of the upper triple clamp.

- Tighten screws 2.

Guideline

| | | |
|-------------------------|----|------------------------|
| Screw, top triple clamp | M8 | 17 Nm (12.5 lbf ft) |
|-------------------------|----|------------------------|

- Tighten screws 3.

Guideline

| | | |
|----------------------------|----|------------------------|
| Screw, bottom triple clamp | M8 | 15 Nm (11.1 lbf ft) |
|----------------------------|----|------------------------|

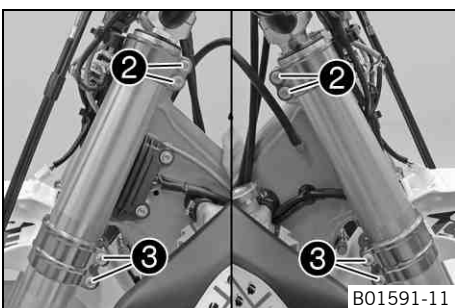

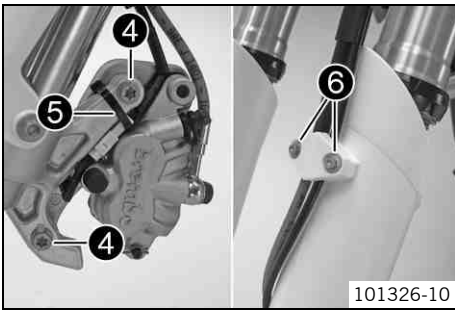

- Position the brake caliper and mount and tighten screws ④.

Guideline

| | | | |
|----------------------------|----|------------------------|---------------|
| Screw, front brake caliper | M8 | 25 Nm (18.4 lbf ft) | Loctite® 243™ |
|----------------------------|----|------------------------|---------------|

- Mount cable binder ⑤.
- Position the brake line, wiring harness, and clamp. Mount and tighten screws ⑥.

Finishing work

- Install the front wheel. 🛠️ (☞ p. 90)
- Refit the headlight mask with the headlight. (☞ p. 99)
- Check the headlight setting. (☞ p. 100)

12.9 Removing the fork protector 🛠️

Preparatory work

- Remove the headlight mask with the headlight. (☞ p. 98)
- Raise the motorcycle with the lift stand. (☞ p. 56)
- Remove the front wheel. 🛠️ (☞ p. 90)
- Remove the fork legs. 🛠️ (☞ p. 57)

Main work

- Remove screws ① on the left fork leg. Remove the fork protector upwards.
- Remove the screws on the right fork leg. Remove the fork protector upwards.

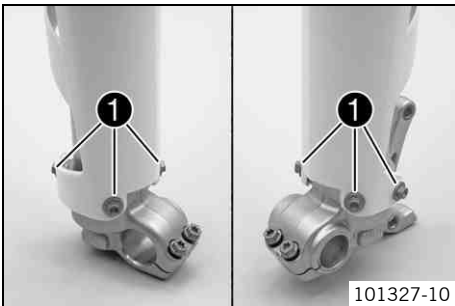

12.10 Installing the fork protector 🛠️

Main work

- Position the fork protector on the left fork leg. Mount and tighten screws ①.

Guideline

| | | |
|---------------------------|----|--------------------|
| Remaining screws, chassis | M6 | 10 Nm (7.4 lbf ft) |
|---------------------------|----|--------------------|

- Position the fork protector on the right fork leg. Mount and tighten the screws.

Guideline

| | | |
|---------------------------|----|--------------------|
| Remaining screws, chassis | M6 | 10 Nm (7.4 lbf ft) |
|---------------------------|----|--------------------|

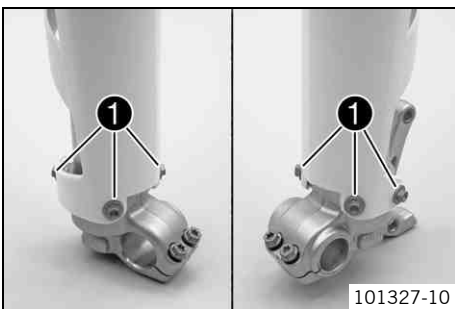

Finishing work

- Install the fork legs. 🛠️ (☞ p. 58)
- Install the front wheel. 🛠️ (☞ p. 90)
- Refit the headlight mask with the headlight. (☞ p. 99)
- Check the headlight setting. (☞ p. 100)

12.11 Removing the lower triple clamp 🛠️ (EXC-F EU, EXC-F AUS, XCF-W)

Preparatory work

- Remove the headlight mask with the headlight. (☞ p. 98)
- Raise the motorcycle with the lift stand. (☞ p. 56)
- Remove the front wheel. 🛠️ (☞ p. 90)
- Remove the fork legs. 🛠️ (☞ p. 57)
- Remove the front fender. (☞ p. 66)
- Remove the handlebar cushion.

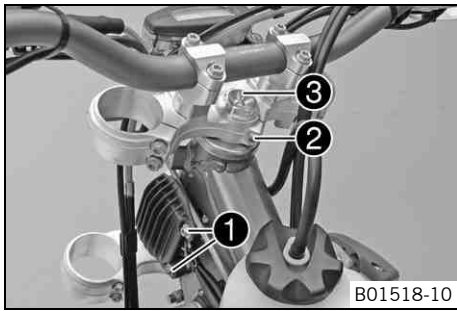

Main work

- Open the cable holder in front of the right radiator and detach the wiring harness.
- Remove screws ❶ and hang the voltage regulator to one side.
- Release screw ❷ and remove screw ❸. Take off the upper triple clamp with the handlebar and set it aside.



Info

Protect the motorcycle and its attachments against damage by covering them.
Do not bend the cables and lines.

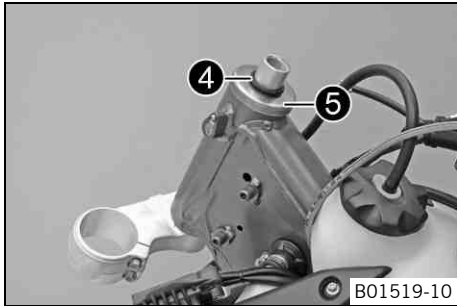

- Remove O-ring ❹. Remove protective ring ❺.
- Take out the lower triple clamp with the steering stem.
- Take out the upper steering head bearing.

12.12 Removing the lower triple clamp 🛠️ (EXC-F SIX DAYS)

Preparatory work

- Remove the headlight mask with the headlight. (🔧 p. 98)
- Raise the motorcycle with the lift stand. (🔧 p. 56)
- Remove the front wheel. 🛠️ (🔧 p. 90)
- Remove the fork legs. 🛠️ (🔧 p. 57)
- Remove the front fender. (🔧 p. 66)
- Remove the handlebar cushion.

Main work

- Open the cable holder in front of the right radiator and detach the wiring harness.
- Remove screws ❶ and hang the voltage regulator to the side.
- Remove screw ❷. Remove screw ❸, take off the upper triple clamp with the handlebar and set it aside.



Info

Protect the motorcycle and its attachments against damage by covering them.
Do not bend the cables and lines.

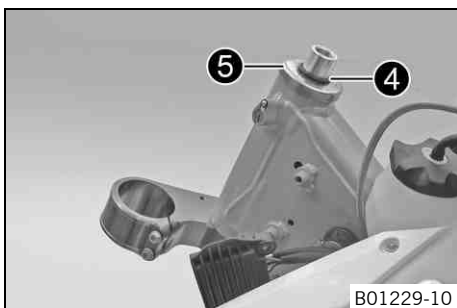
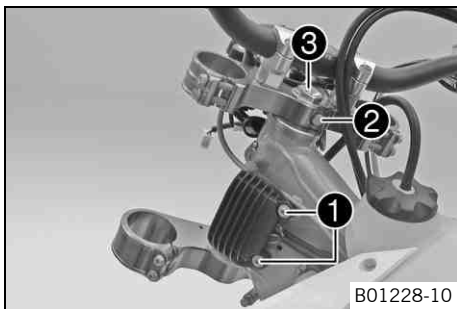

- Remove O-ring ❹. Remove protective ring ❺.
- Take out the lower triple clamp with the steering stem.
- Take out the upper steering head bearing.

12.13 Installing the lower triple clamp (EXC-F EU, EXC-F AUS, XCF-W)

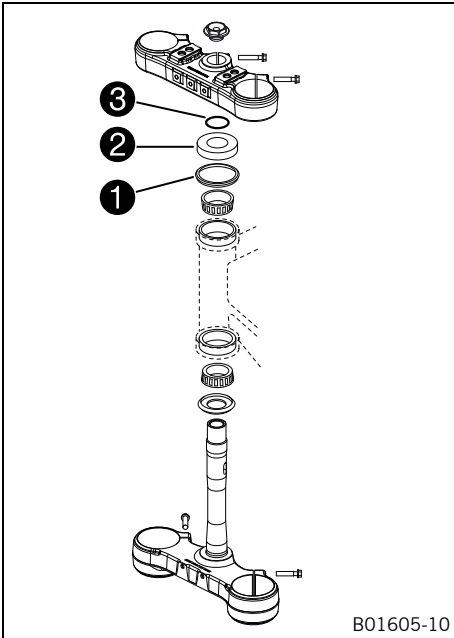

B01605-10

Main work

- Clean the bearing and sealing elements, check for damage, and grease.

| |
|----------------------------------|
| High viscosity grease (☛ p. 128) |
|----------------------------------|

- Insert the lower triple clamp with the steering stem. Mount the upper steering head bearing.
- Check whether the upper steering head seal ❶ is correctly positioned.
- Slide on protective ring ❷ and O-ring ❸.

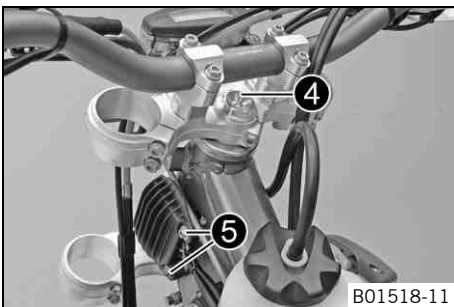

B01518-11

- Position the upper triple clamp with the handlebar.
- Mount screw ❷ but do not tighten yet.
- Position the clutch line, wiring harness, and voltage regulator. Mount and tighten screws ❸.

Guideline

| | | |
|---------------------------|----|--------------------|
| Remaining screws, chassis | M6 | 10 Nm (7.4 lbf ft) |
|---------------------------|----|--------------------|

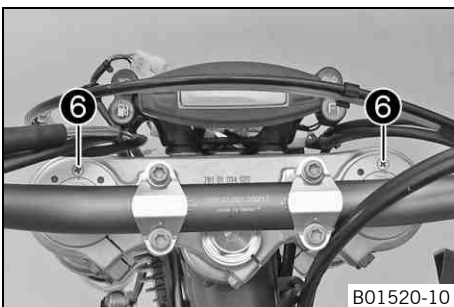

B01520-10

- Position the fork legs.
- ✓ Position bleeder screws ❹ toward the front.

Info

Grooves are milled into the side of the upper end of the fork legs. The second milled groove (from the top) must be flush with the top edge of the upper triple clamp.

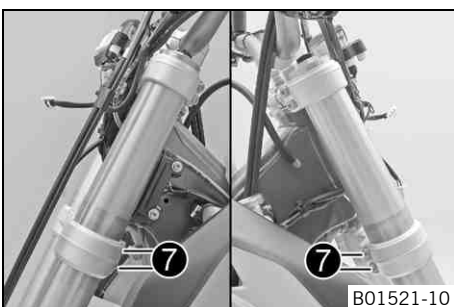

B01521-10

- Tighten screws ❺.

Guideline

| | | |
|----------------------------|----|------------------------|
| Screw, bottom triple clamp | M8 | 15 Nm (11.1 lbf ft) |
|----------------------------|----|------------------------|



B01522-10

- Tighten screw ❷.

Guideline

| | | |
|--------------------------|---------|--------------------|
| Screw, top steering head | M20x1.5 | 12 Nm (8.9 lbf ft) |
|--------------------------|---------|--------------------|

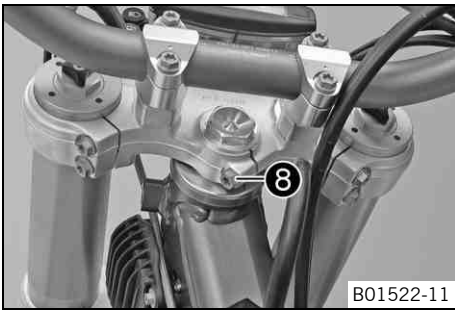

- Tighten screw 8.

Guideline

| | | |
|--------------------------|----|------------------------|
| Screw, top steering stem | M8 | 20 Nm (14.8 lbf ft) |
|--------------------------|----|------------------------|

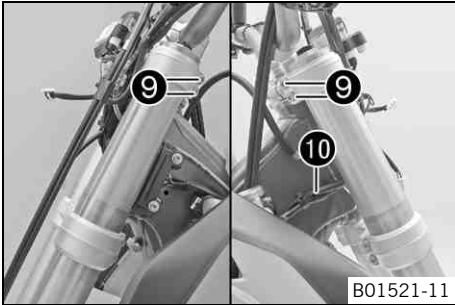

- Tighten screws 9.

Guideline

| | | |
|-------------------------|----|------------------------|
| Screw, top triple clamp | M8 | 20 Nm (14.8 lbf ft) |
|-------------------------|----|------------------------|

- Secure the wiring harness with cable holder 10.

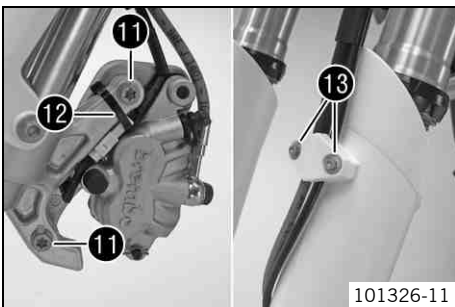

- Position the brake caliper. Mount and tighten screws 11.

Guideline

| | | | |
|----------------------------|----|------------------------|---------------|
| Screw, front brake caliper | M8 | 25 Nm (18.4 lbf ft) | Loctite® 243™ |
|----------------------------|----|------------------------|---------------|

- Mount cable binder 12.
- Position the brake line, wiring harness, and clamp. Mount and tighten screws 13.

Finishing work

- Mount the handlebar cushion.
- Install the front fender. (☛ p. 66)
- Install the front wheel. 🛞 (☛ p. 90)
- Refit the headlight mask with the headlight. (☛ p. 99)
- Check that the wiring harness, throttle cables and brake and clutch lines can move freely and are routed correctly.
- Check the steering head bearing play. (☛ p. 64)
- Remove the motorcycle from the lift stand. (☛ p. 56)
- Check the headlight setting. (☛ p. 100)

12.14 Installing the lower triple clamp (EXC-F SIX DAYS)

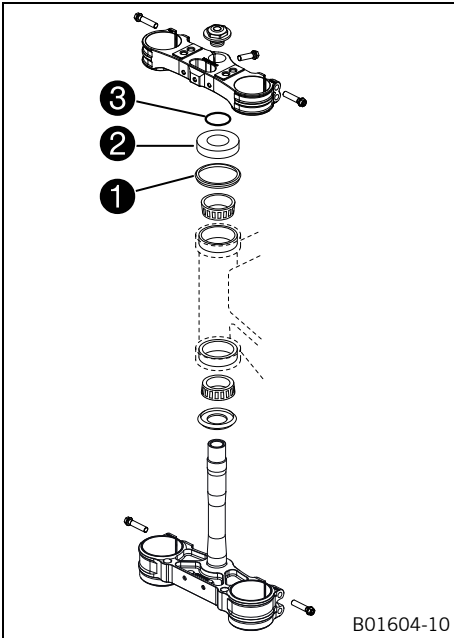

Main work

- Clean the bearing and sealing elements, check for damage, and grease.

| |
|----------------------------------|
| High viscosity grease (☛ p. 128) |
|----------------------------------|

- Insert the lower triple clamp with the steering stem. Mount the upper steering head bearing.
- Check whether the upper steering head seal ❶ is correctly positioned.
- Slide on protective ring ❷ and O-ring ❸.

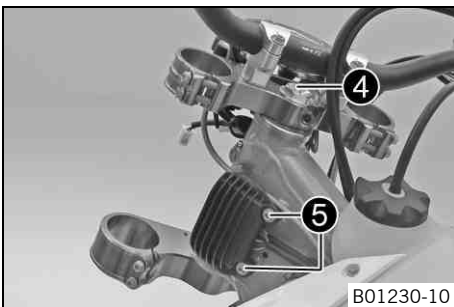

- Position the upper triple clamp with the handlebar.
- Mount screw ❹ but do not tighten yet.
- Position the clutch line, wiring harness, and voltage regulator. Mount and tighten screws ❺.

Guideline

| | | |
|---------------------------|----|--------------------|
| Remaining screws, chassis | M6 | 10 Nm (7.4 lbf ft) |
|---------------------------|----|--------------------|



- Position the fork legs.
- ✓ Position bleeder screws ❻ toward the front.

i Info

The rebound damping is located in the right fork leg **REB** (red adjusting screw). The compression damping is located in the left fork leg **COMP** (white adjusting screw). Grooves are milled into the side of the upper end of the fork legs. The second milled groove (from the top) must be flush with the top edge of the upper triple clamp.

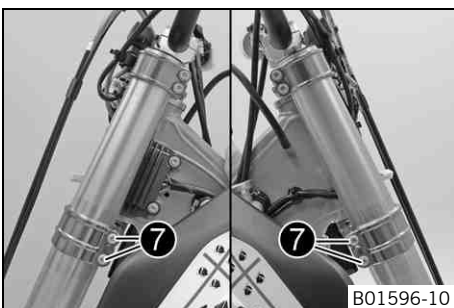

- Tighten screws ❷.

Guideline

| | | |
|----------------------------|----|---------------------|
| Screw, bottom triple clamp | M8 | 15 Nm (11.1 lbf ft) |
|----------------------------|----|---------------------|

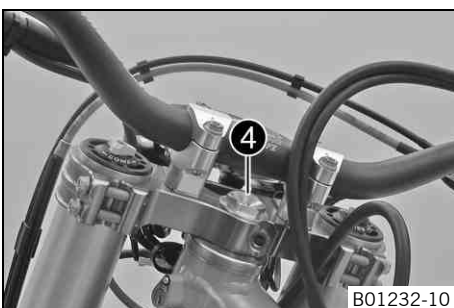

- Tighten screw ❹.

Guideline

| | | |
|--------------------------|---------|--------------------|
| Screw, top steering head | M20x1.5 | 12 Nm (8.9 lbf ft) |
|--------------------------|---------|--------------------|

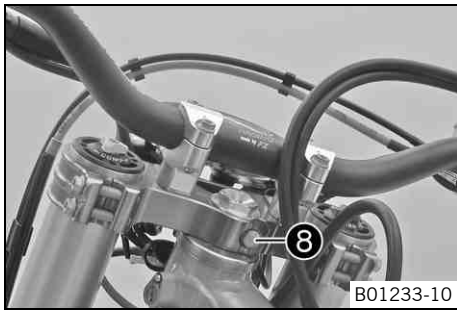

- Mount and tighten screw 8.

Guideline

| | | | |
|--------------------------|----|------------------------|---------------|
| Screw, top steering stem | M8 | 17 Nm (12.5 lbf ft) | Loctite® 243™ |
|--------------------------|----|------------------------|---------------|

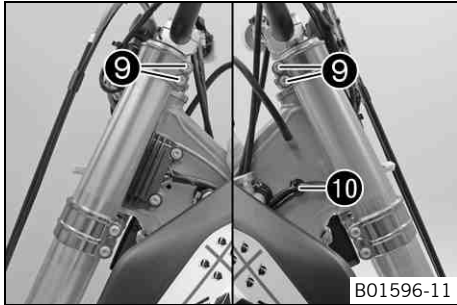

- Tighten screws 9.

Guideline

| | | | |
|-------------------------|----|------------------------|--|
| Screw, top triple clamp | M8 | 17 Nm (12.5 lbf ft) | |
|-------------------------|----|------------------------|--|

- Secure the wiring harness with cable holder 10.

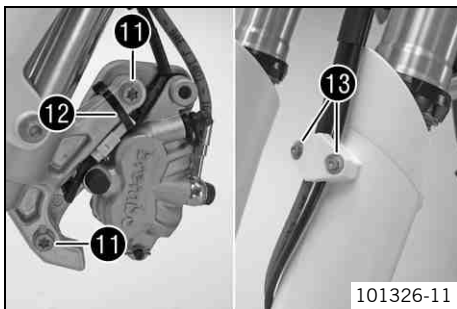

- Position the brake caliper. Mount and tighten screws 11.

Guideline

| | | | |
|----------------------------|----|------------------------|---------------|
| Screw, front brake caliper | M8 | 25 Nm (18.4 lbf ft) | Loctite® 243™ |
|----------------------------|----|------------------------|---------------|

- Mount cable binder 12.
- Position the brake line, wiring harness, and clamp. Mount and tighten screws 13.

Finishing work

- Mount the handlebar cushion.
- Install the front fender. (☛ p. 66)
- Install the front wheel. ☛ (☛ p. 90)
- Refit the headlight mask with the headlight. (☛ p. 99)
- Check that the wiring harness, throttle cables and brake and clutch lines can move freely and are routed correctly.
- Check the steering head bearing play. (☛ p. 64)
- Remove the motorcycle from the lift stand. (☛ p. 56)
- Check the headlight setting. (☛ p. 100)

12.15 Checking the steering head bearing play



Warning

Danger of accidents Unstable vehicle handling from incorrect steering head bearing play.

- Adjust the steering head bearing play without delay. (Your authorized KTM workshop will be glad to help.)



Info

If the bike is ridden with play in the steering head bearing, the bearing and the bearing seats in the frame can become damaged over time.

Preparatory work

- Raise the motorcycle with the lift stand. (☛ p. 56)

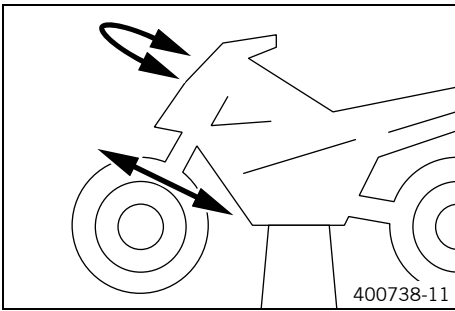

Main work

- Move the handlebar to the straight-ahead position. Move the fork legs to and fro in the direction of travel.

No play should be noticeable in the steering head bearing.

- » If there is noticeable play present:

(EXC-F SIX DAYS)

- Adjust the play of the steering head bearing. (🔧) (📖 p. 65)

(EXC-F EU, EXC-F AUS, XCF-W)

- Adjust the play of the steering head bearing. (🔧) (📖 p. 65)

- Move the handlebar to and fro over the entire steering range.

The handlebar must be able to move easily over the entire steering range. No resting locations should be noticeable.

- » If click positions are noticeable:

(EXC-F SIX DAYS)

- Adjust the play of the steering head bearing. (🔧) (📖 p. 65)

(EXC-F EU, EXC-F AUS, XCF-W)

- Adjust the play of the steering head bearing. (🔧) (📖 p. 65)

- Check the steering head bearing and replace if required.

Finishing work

- Remove the motorcycle from the lift stand. (📖 p. 56)

12.16 Adjusting the play of the steering head bearing (🔧) (EXC-F EU, EXC-F AUS, XCF-W)

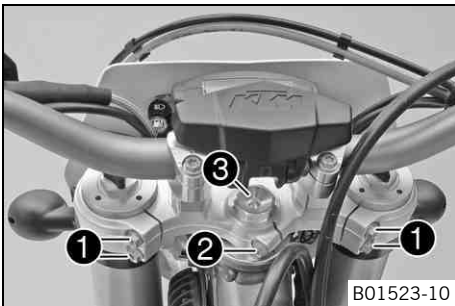

Preparatory work

- Raise the motorcycle with the lift stand. (📖 p. 56)

Main work

- Loosen screws ① and ②.
- Loosen and retighten screw ③.

Guideline

| | | |
|--------------------------|---------|--------------------|
| Screw, top steering head | M20x1.5 | 12 Nm (8.9 lbf ft) |
|--------------------------|---------|--------------------|

- Using a plastic hammer, tap lightly on the upper triple clamp to avoid strains.
- Tighten screws ①.

Guideline

| | | |
|-------------------------|----|---------------------|
| Screw, top triple clamp | M8 | 20 Nm (14.8 lbf ft) |
|-------------------------|----|---------------------|

- Tighten screw ②.

Guideline

| | | |
|--------------------------|----|---------------------|
| Screw, top steering stem | M8 | 20 Nm (14.8 lbf ft) |
|--------------------------|----|---------------------|

Finishing work

- Check the steering head bearing play. (📖 p. 64)
- Remove the motorcycle from the lift stand. (📖 p. 56)

12.17 Adjusting the play of the steering head bearing (🔧) (EXC-F SIX DAYS)

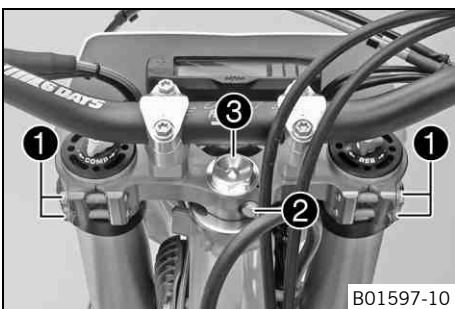

Preparatory work

- Raise the motorcycle with the lift stand. (📖 p. 56)

Main work

- Loosen screws ①. Remove screw ②.
- Loosen and retighten screw ③.

Guideline

| | | |
|--------------------------|---------|--------------------|
| Screw, top steering head | M20x1.5 | 12 Nm (8.9 lbf ft) |
|--------------------------|---------|--------------------|

- Using a plastic hammer, tap lightly on the upper triple clamp to avoid strains.
- Fully tighten screws ①.

Guideline

| | | |
|-------------------------|----|---------------------|
| Screw, top triple clamp | M8 | 17 Nm (12.5 lbf ft) |
|-------------------------|----|---------------------|

- Mount and tighten screw ②.

Guideline

| | | | |
|--------------------------|----|------------------------|---------------|
| Screw, top steering stem | M8 | 17 Nm (12.5 lbf ft) | Loctite® 243™ |
|--------------------------|----|------------------------|---------------|

Finishing work

- Check the steering head bearing play. (☛ p. 64)
- Remove the motorcycle from the lift stand. (☛ p. 56)

12.18 Greasing the steering head bearing ☛

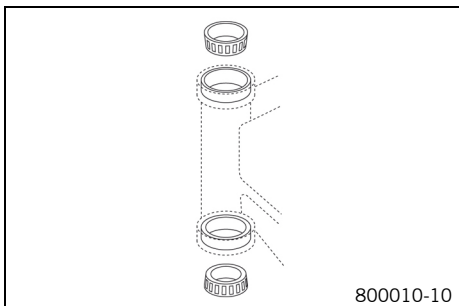

(EXC-F SIX DAYS)

- Remove the lower triple clamp. ☛ (☛ p. 60)
- Install the lower triple clamp. ☛ (☛ p. 63)

(EXC-F EU, EXC-F AUS, XCF-W)

- Remove the lower triple clamp. ☛ (☛ p. 59)
- Install the lower triple clamp. ☛ (☛ p. 61)

12.19 Removing the front fender

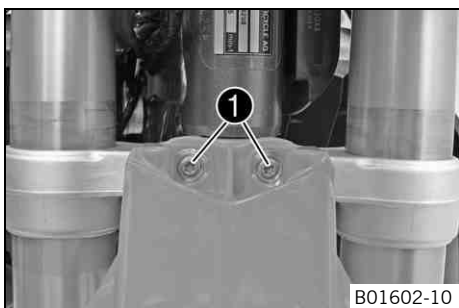

Preparatory work

- Remove the headlight mask with the headlight. (☛ p. 98)

Main work

- Remove screws ①.

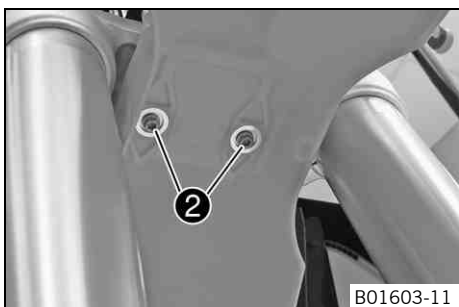

- Remove screws ②. Remove the front fender.

12.20 Installing the front fender

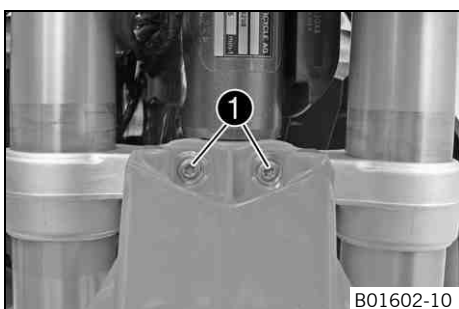

Main work

- Position the front fender. Mount and tighten screws ①.

Guideline

| | | |
|---------------------------|----|--------------------|
| Remaining screws, chassis | M6 | 10 Nm (7.4 lbf ft) |
|---------------------------|----|--------------------|

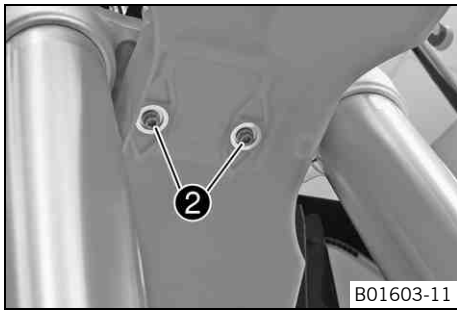

- Mount and tighten screws 2.

Guideline

| | | |
|---------------------------|----|--------------------|
| Remaining screws, chassis | M6 | 10 Nm (7.4 lbf ft) |
|---------------------------|----|--------------------|

Finishing work

- Refit the headlight mask with the headlight. (☛ p. 99)
- Check the headlight setting. (☛ p. 100)

12.21 Removing the shock absorber ☛

Preparatory work

- Raise the motorcycle with the lift stand. (☛ p. 56)

Main work

- Remove screw 1 and lower the rear wheel with the swing arm as far as possible without blocking the rear wheel. Fix the rear wheel in this position.
- Remove screw 2, push splash protector 3 to the side, and remove the shock absorber.

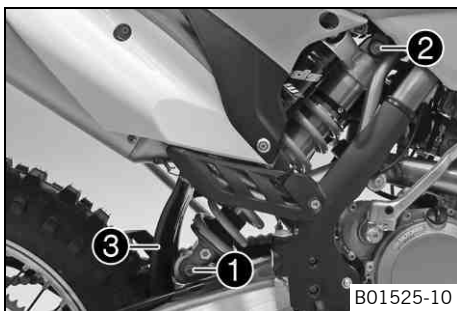

12.22 Installing the shock absorber ☛

Main work

- Push splash protector 1 to the side and position the shock absorber. Mount and tighten screw 2.

Guideline

| | | | |
|---------------------------|-----|-------------------|----------------|
| Screw, top shock absorber | M12 | 80 Nm (59 lbf ft) | Loctite® 2701™ |
|---------------------------|-----|-------------------|----------------|

- Mount and tighten screw 3.

Guideline

| | | | |
|------------------------------|-----|-------------------|----------------|
| Screw, bottom shock absorber | M12 | 80 Nm (59 lbf ft) | Loctite® 2701™ |
|------------------------------|-----|-------------------|----------------|

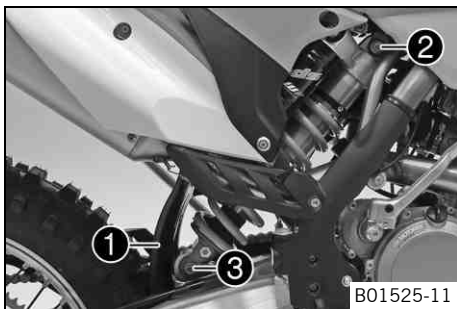

i Info

The heim joint for the shock absorber at the swing arm is Teflon coated. It must not be greased with grease or with other lubricants. Lubricants dissolve the Teflon coating, thereby drastically reducing the service life.

Finishing work

- Remove the motorcycle from the lift stand. (☛ p. 56)

12.23 Removing the seat

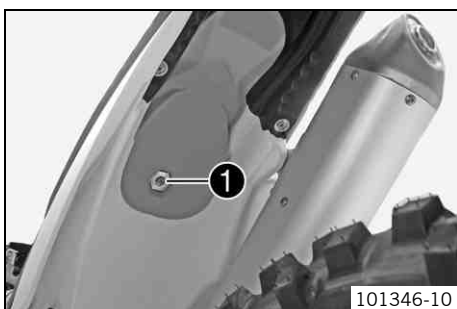

- Remove screw 1.
- Lift up the seat at the rear, pull it back and then remove it from above.

12.24 Mounting the seat



- Hook in the front of the seat at the collar sleeve of the fuel tank, lower it at the rear and simultaneously push it forward.
- Make sure that the seat is correctly locked in.
- Mount and tighten the screw of the seat fixing.

Guideline

| | | |
|---------------------------|----|--------------------|
| Remaining screws, chassis | M6 | 10 Nm (7.4 lbf ft) |
|---------------------------|----|--------------------|

12.25 Removing the air filter box lid

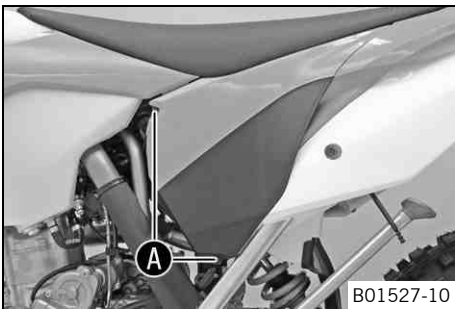

- Pull off the air filter box lid in area **A** to the side and remove to the front.

12.26 Installing the air filter box lid

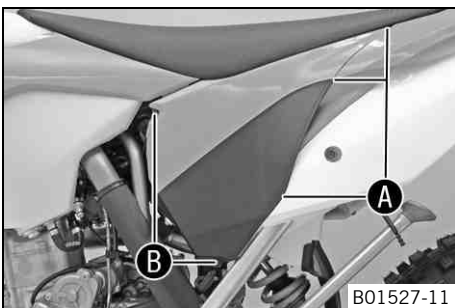

- Insert the air filter box lid into the rear area **A** and clip it into the front area **B**.

12.27 Removing the air filter

Note

Engine failure Unfiltered intake air has a negative effect on the service life of the engine.

- Never ride the vehicle without an air filter since dust and dirt can get into the engine and result in increased wear.



Warning

Environmental hazard Hazardous substances cause environmental damage.

- Oil, grease, filters, fuel, cleaners, brake fluid, etc., should be disposed of as stipulated in applicable regulations.

Preparatory work

- Remove the air filter box lid. (☞ p. 68)

Main work

- Detach air filter holder **1** at the bottom and swing it to one side. Remove the air filter with the air filter support.
- Remove the air filter from the air filter support.

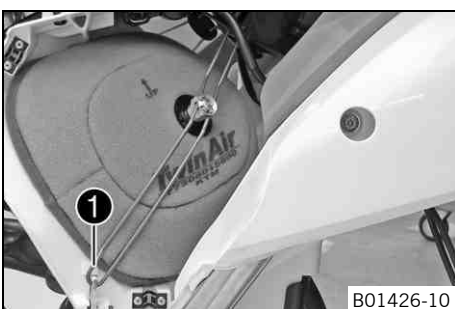

12.28 Installing the air filter

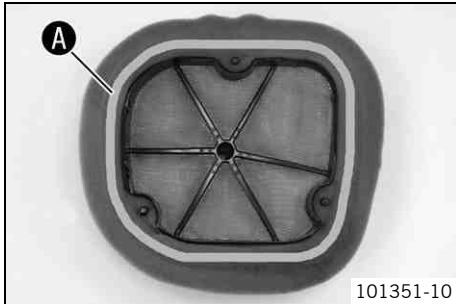

101351-10

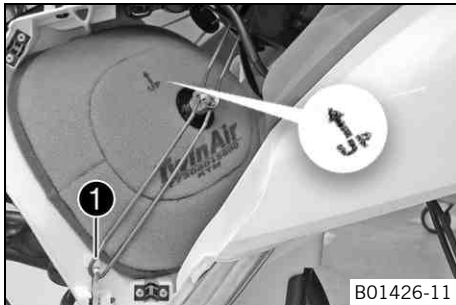

B01426-11

Main work

- Mount the clean air filter on the air filter support.
- Grease the air filter in area **A**.

Long-life grease (☛ p. 128)

- Insert both parts together, position them and fasten them using air filter holder **1**.
- ✓ The arrow of marking **UP** faces up.

Info

If the air filter is not correctly mounted, dust and dirt can enter the engine and cause damage.

Finishing work

- Install the air filter box lid. (☛ p. 68)

12.29 Cleaning the air filter and air filter box

Warning

Environmental hazard Hazardous substances cause environmental damage.

- Oil, grease, filters, fuel, cleaners, brake fluid, etc., should be disposed of as stipulated in applicable regulations.

Info

Do not clean the air filter with fuel or petroleum since these substances attack the foam.

Preparatory work

- Remove the air filter box lid. (☛ p. 68)
- Remove the air filter. (☛ p. 68)

Main work

- Wash the air filter thoroughly in special cleaning liquid and allow it to dry properly.

Air filter cleaner (☛ p. 128)

Info

Only press the air filter to dry it, never wring it out.

- Oil the dry air filter with a high quality filter oil.

Oil for foam air filter (☛ p. 129)

- Clean the air filter box.
- Check the intake flange for damage and firm seating.

Finishing work

- Install the air filter. (☛ p. 69)
- Install the air filter box lid. (☛ p. 68)



S00044-10

12.30 Sealing the air filter box

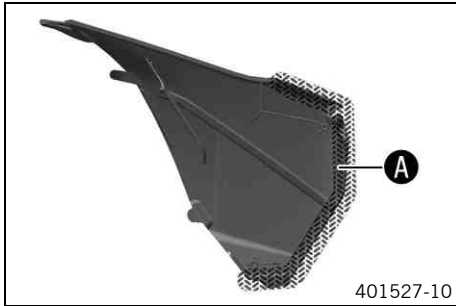

- Seal the air filter box in the marked area **A**.

12.31 Removing main silencer



Warning

Danger of burns The exhaust system gets very hot when the vehicle is driven.

- Allow the exhaust system to cool down. Do not touch hot components.

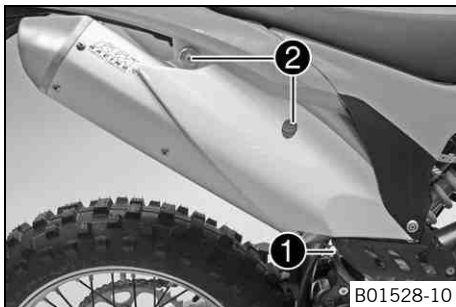

- Disconnect spring **1**.
- Remove screws **2** and take off main silencer.

12.32 Installing the main silencer

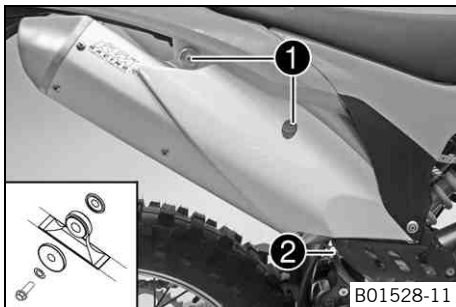

- Mount the main silencer. Mount screws **1** but do not tighten yet.
- Reconnect spring **2**.
- Tighten screws **1**.

Guideline

| | | |
|---------------------------|----|--------------------|
| Remaining screws, chassis | M6 | 10 Nm (7.4 lbf ft) |
|---------------------------|----|--------------------|

12.33 Changing the glass fiber yarn filling of the main silencer



Warning

Danger of burns The exhaust system gets very hot when the vehicle is driven.

- Allow the exhaust system to cool down. Do not touch hot components.



Info

Over time, the fibers of the glass fiber yarn escape and the damper "burns" out. Not only is the noise level higher, the performance characteristic changes.

Preparatory work

- Remove the main silencer. (☛ p. 70)

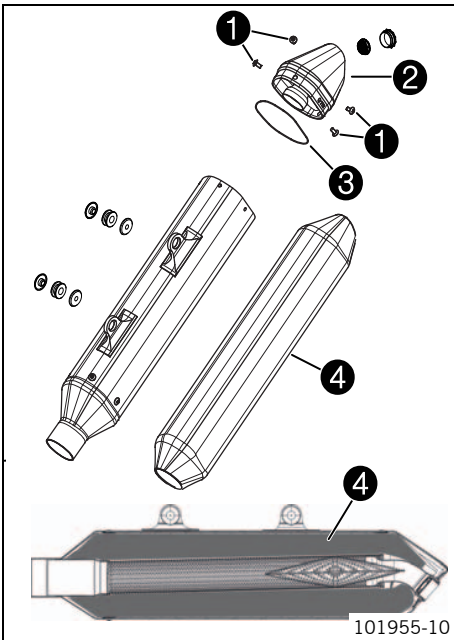

Main work
(All EXC-F models)

- Remove screws ① and silencer cap ② with O-ring ③.
- Remove the old glass fiber yarn filling.
- Clean the parts that need to be reinstalled and check for damage.
- Slide the new glass fiber yarn filling ④ into the main silencer.
- Mount the O-ring on the silencer cap.
- Position the silencer cap. Mount and tighten the screws.

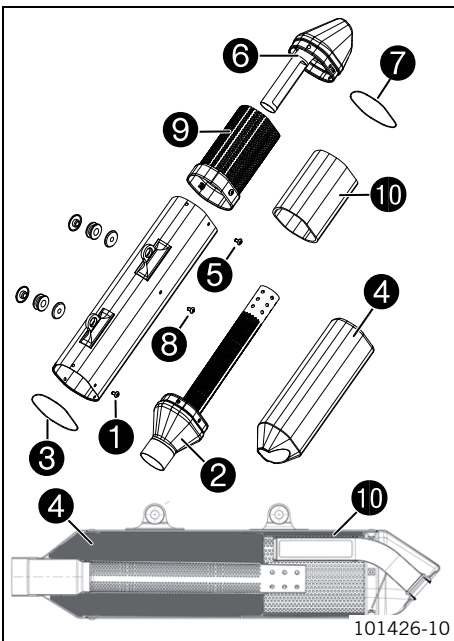

(XCF-W)

- Remove screws ① of connecting cap ②.
- Take off the connecting cap with the perforated pipe, O-ring ③ and glass fiber yarn filling ④.
- Remove screw ⑤ and take off silencer cap ⑥ with O-ring ⑦.
- Remove screw ⑧ and remove insert ⑨ together with stuffing yarn ⑩.
- Clean the parts that need to be reinstalled and check for damage.
- Mount the new stuffing yarn on the insert and fasten with adhesive tape.
- Slide the insert with the stuffing yarn into the main silencer and fasten with the screw.
- Mount the O-ring on the connecting cap.
- Slide the new glass fiber yarn filling over the perforated pipe.
- Mount the connecting cap with the glass fiber yarn filling in the main silencer.

i Info

Slide the glass fiber yarn filling into the main silencer with a blunt tool.

- Mount and tighten the screws.
- Mount the O-ring on the silencer cap.
- Position the silencer cap. Mount and tighten the screws.

Finishing work

- Install the main silencer. (☛ p. 70)

12.34 Removing the fuel tank ☛



Danger

Fire hazard Fuel is highly flammable.

- Never refuel the vehicle near open flames or burning cigarettes, and always switch off the engine first. Be careful that no fuel is spilt, especially on hot vehicle components. Clean up spilt fuel immediately.
- The fuel in the fuel tank expands when warm and may emerge if overfilled. Follow the instructions on refueling.



Warning

Danger of poisoning Fuel is poisonous and a health hazard.

- Fuel must not come into contact with the skin, eyes, or clothing. Do not breathe in the fuel vapors. If contact occurs with the eyes, rinse with water immediately and contact a physician. Immediately clean contaminated areas on the skin with soap and water. If fuel is swallowed, contact a physician immediately. Change clothing that is contaminated with fuel. Store fuel properly in a suitable canister and keep away from children.

Preparatory work

- Remove the seat. (☛ p. 67)

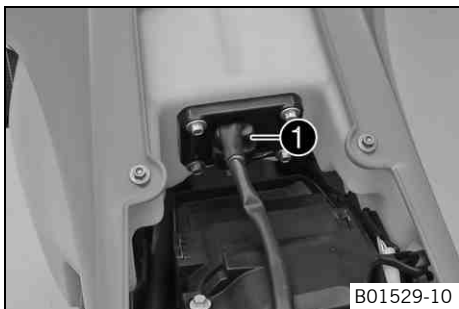

Main work

- Disconnect electric plug-in connection ❶ of the fuel pump.
- Remove the tube from the fuel tank breather.

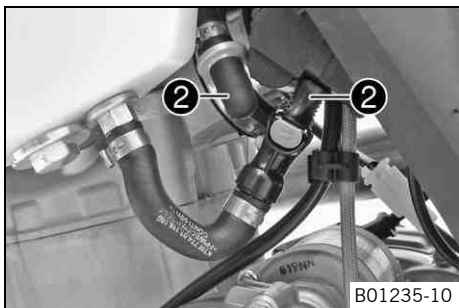

- Thoroughly clean the plug-in connection of the fuel line using compressed air.



Info

Under no circumstances should dirt enter into the fuel line. Dirt in the fuel line clogs the injection valve.

- Disconnect the plug-in connection of the fuel line.
- Mount wash cap set ❷.

Wash cap set (81212016100)

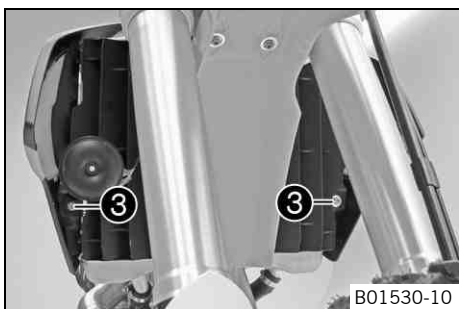

- Remove screws ❸ with the collar bushings and horn.

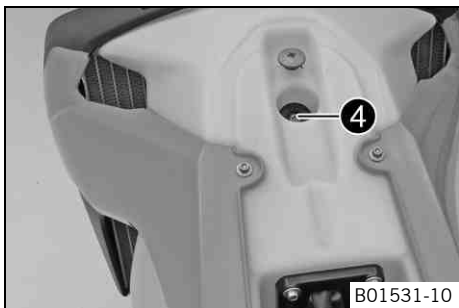

- Remove screw ❹ with the rubber bushing.

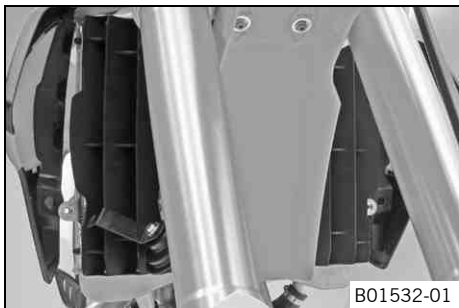

- Pull both spoilers off of the sides of the radiator bracket and lift off the fuel tank.

12.35 Installing the fuel tank 🛠️



Danger

Fire hazard Fuel is highly flammable.

- Never refuel the vehicle near open flames or burning cigarettes, and always switch off the engine first. Be careful that no fuel is spilt, especially on hot vehicle components. Clean up spilt fuel immediately.
- The fuel in the fuel tank expands when warm and may emerge if overfilled. Follow the instructions on refueling.



Warning

Danger of poisoning Fuel is poisonous and a health hazard.

- Fuel must not come into contact with the skin, eyes, or clothing. Do not breathe in the fuel vapors. If contact occurs with the eyes, rinse with water immediately and contact a physician. Immediately clean contaminated areas on the skin with soap and water. If fuel is swallowed, contact a physician immediately. Change clothing that is contaminated with fuel.

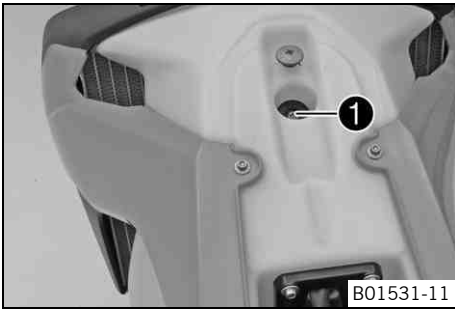

Main work

- Check the throttle cable routing. (☛ p. 77)
- Position the fuel tank and fit the two spoilers to the sides of the radiator bracket.
- Make sure that no cables are trapped or damaged.
- Mount the fuel tank breather.
- Mount and tighten screw ❶ with the rubber bushing.

Guideline

| | | |
|---------------------------|----|--------------------|
| Remaining screws, chassis | M6 | 10 Nm (7.4 lbf ft) |
|---------------------------|----|--------------------|

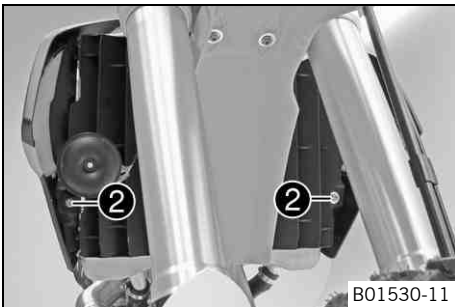

- Position the horn, and fit and tighten screws ❷ with collar bushings.

Guideline

| | | |
|---------------------------|----|--------------------|
| Remaining screws, chassis | M6 | 10 Nm (7.4 lbf ft) |
|---------------------------|----|--------------------|

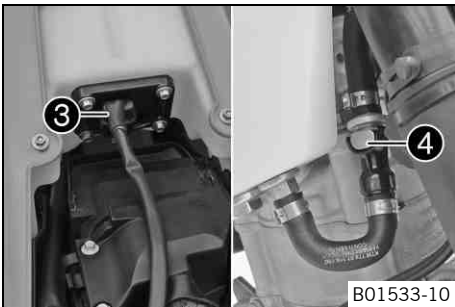

- Connect the electrical plug-in connection ❸.
- Remove the wash cap set.
- Thoroughly clean the plug-in connection of the fuel line using compressed air.



Info

Never let dirt enter the fuel line. Dirt in the fuel line clogs the injection valve.

- Lubricate the O-ring and connect plug-in connection ❹ of the fuel line.



Info

Route the cable and fuel line at a safe distance from the exhaust system.

Finishing work

- Mount the seat. (☛ p. 68)

12.36 Checking for chain dirt accumulation

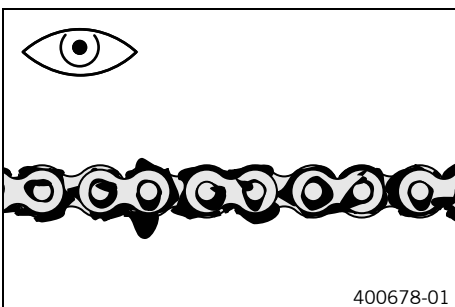

- Check the chain for coarse dirt accumulation.
 - » If the chain is very dirty:
 - Clean the chain. (☛ p. 74)

12.37 Cleaning the chain

Warning
Danger of accidents Oil or grease on the tires reduces their grip.
 – Remove oil and grease with a suitable cleaning material.

Warning
Danger of accidents Reduced braking efficiency due to oil or grease on the brake discs.
 – Always keep the brake discs free of oil and grease, and clean them with brake cleaner when necessary.

Warning
Environmental hazard Hazardous substances cause environmental damage.
 – Oil, grease, filters, fuel, cleaners, brake fluid, etc., should be disposed of as stipulated in applicable regulations.

i Info
 The service life of the chain depends largely on its maintenance.

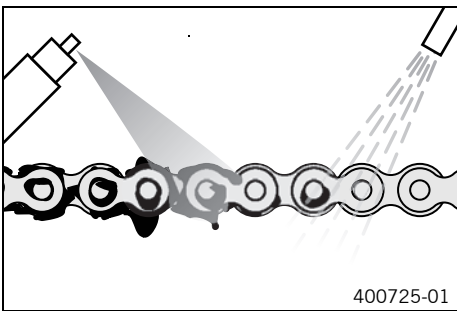

– Clean the chain regularly and then treat with chain spray.

| |
|---------------------------------|
| Chain cleaner (☛ p. 128) |
| Off-road chain spray (☛ p. 128) |

12.38 Checking the chain tension

Warning
Danger of accidents Danger caused by incorrect chain tension.
 – If the chain is too taut, the components of the secondary power transmission (chain, engine sprocket, rear sprocket, bearings in the transmission and in the rear wheel) will be under additional load. In addition to premature wear, this can cause the chain or the countershaft of the transmission to break in extreme cases. If the chain is too loose, however, it may fall off the engine sprocket or rear sprocket and block the rear wheel or damage the engine. Ensure that the chain tension is correct and adjust it if necessary.

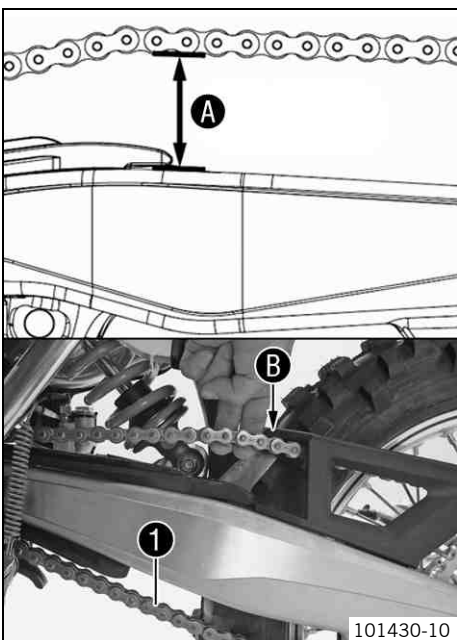

Preparatory work

– Raise the motorcycle with the lift stand. (☛ p. 56)

Main work

– Push the chain at the end of the chain sliding component upwards to measure the chain tension **A**.

i Info
 The lower chain section **1** must be taut.
 When the chain guard is mounted, it must be possible to pull up the chain at least to the point where it makes contact with chain guard **B**.
 Chain wear is not always even, so you should repeat this measurement at different chain positions.

| | |
|---------------|-------------------------------|
| Chain tension | 55... 58 mm (2.17... 2.28 in) |
|---------------|-------------------------------|

» If the chain tension does not meet specifications:
 – Adjust the chain tension. (☛ p. 75)

Finishing work

- Remove the motorcycle from the lift stand. (🔧 p. 56)

12.39 Adjusting the chain tension

Warning

Danger of accidents Danger caused by incorrect chain tension.

- If the chain is too taut, the components of the secondary power transmission (chain, engine sprocket, rear sprocket, bearings in the transmission and in the rear wheel) will be under additional load. In addition to premature wear, this can cause the chain or the countershaft of the transmission to break in extreme cases. If the chain is too loose, however, it may fall off the engine sprocket or rear sprocket and block the rear wheel or damage the engine. Ensure that the chain tension is correct and adjust it if necessary.

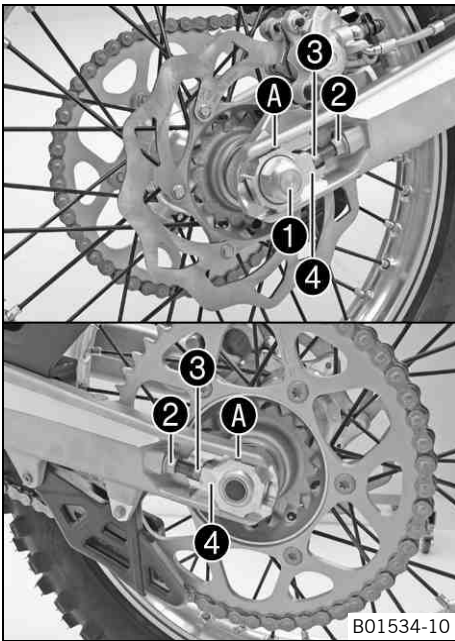

Preparatory work

- Raise the motorcycle with the lift stand. (🔧 p. 56)
- Check the chain tension. (🔧 p. 74)

Main work

- Loosen nut ①.
- Loosen nuts ②.
- Adjust the chain tension by turning adjusting screws ③ left and right.

Guideline

| | |
|--|-------------------------------|
| Chain tension | 55... 58 mm (2.17... 2.28 in) |
| Turn adjusting screws ③ on the left and right so that the markings on the left and right chain adjusters are in the same position relative to the reference marks A. The rear wheel is then correctly aligned. | |

- Tighten nuts ②.
- Make sure that the chain adjusters ④ are fitted correctly on the adjusting screws ③.
- Tighten nut ①.

Guideline

| | | |
|-------------------------|---------|-------------------|
| Nut, rear wheel spindle | M20x1.5 | 80 Nm (59 lbf ft) |
|-------------------------|---------|-------------------|



Info

The wide adjustment range of the chain adjusters (32 mm (1.26 in)) enables different secondary ratios with the same chain length. Chain adjusters ④ can be turned by 180°.

Finishing work

- Remove the motorcycle from the lift stand. (🔧 p. 56)

12.40 Checking the chain, rear sprocket, engine sprocket and chain guide

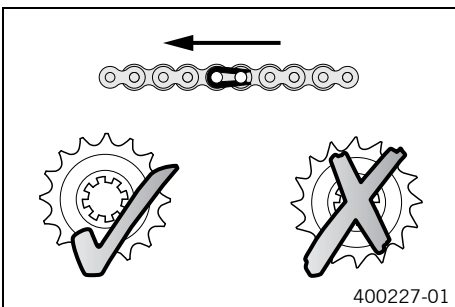

Preparatory work

- Raise the motorcycle with the lift stand. (🔧 p. 56)

Main work

- Shift gear to neutral.
- Check the rear sprocket and engine sprocket for wear.
 - » If the rear sprocket or engine sprocket is worn:
 - Change the power set. 🛠️



Info

The engine sprocket, rear sprocket and chain should always be replaced together.

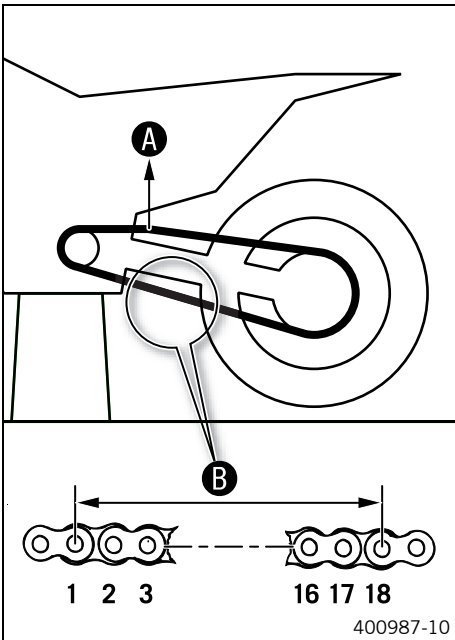

- Pull on the upper part of the chain with the specified weight **A**.

Guideline

| | |
|----------------------------------|----------------------------|
| Weight of chain wear measurement | 10... 15 kg (22... 33 lb.) |
|----------------------------------|----------------------------|

- Measure the distance **B** of 18 chain links in the lower chain section.

i **Info**

Chain wear is not always even, so you should repeat this measurement at different chain positions.

| | |
|--|-------------------|
| Maximum distance B at the longest chain section | 272 mm (10.71 in) |
|--|-------------------|

- » If the distance **B** is greater than the specified measurement:

- Change the power set.

i **Info**

When the chain is replaced, the rear sprocket and engine sprocket should also be changed.

New chains wear out faster on old, worn sprockets.

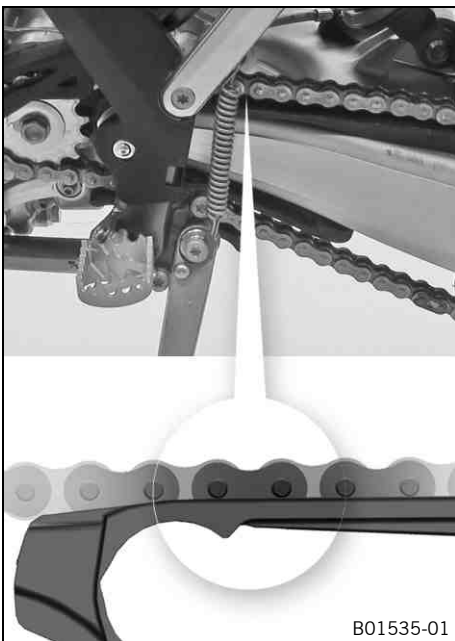

- Check the chain sliding guard for wear.
 - » If the bottom edge of the chain bolt is in line with or below the chain sliding guard:
 - Change the chain sliding guard.

- Check that the chain sliding guard is firmly seated.

- » If the chain sliding guard is loose:

- Tighten the chain sliding guard.

Guideline

| | | | |
|----------------------------|----|----------------------|----------------------|
| Screw, chain sliding guard | M6 | 6 Nm (4.4 lbf ft) | Loctite® 243™ |
|----------------------------|----|----------------------|----------------------|

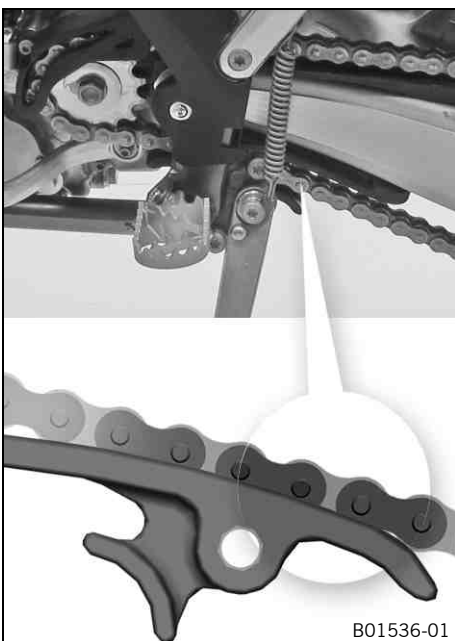

- Check the chain sliding piece for wear.
 - » If the bottom edge of the chain bolt is in line with or below the chain sliding piece:
 - Change the chain sliding piece.

- Check that the chain sliding piece is firmly seated.

- » If the chain sliding piece is loose:

- Tighten the chain sliding piece.

Guideline

| | | |
|----------------------------|----|------------------------|
| Screw, chain sliding piece | M8 | 15 Nm (11.1 lbf ft) |
|----------------------------|----|------------------------|

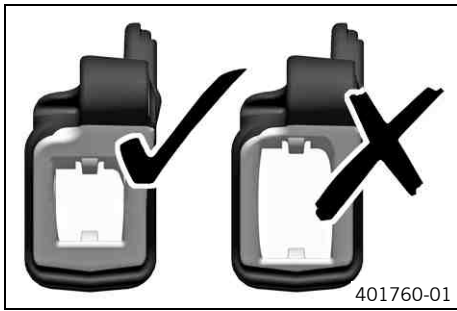

- Check the chain guide for wear.

i Info

Wear is visible on the front of the chain guide.

- » If the light part of the chain guide is worn:
 - Change the chain guide. 🛠️

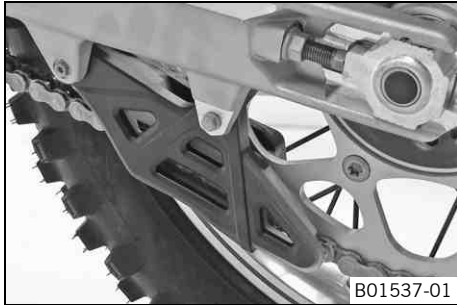

- Check that the chain guide is firmly seated.

- » If the chain guide is loose:
 - Tighten the chain guide.

Guideline

| | | |
|---------------------------|----|-----------------------|
| Remaining screws, chassis | M6 | 10 Nm (7.4 lbf ft) |
| Remaining nuts, chassis | M6 | 10 Nm (7.4 lbf ft) |

Finishing work

- Remove the motorcycle from the lift stand. (🔧 p. 56)

12.41 Checking the frame 🛠️

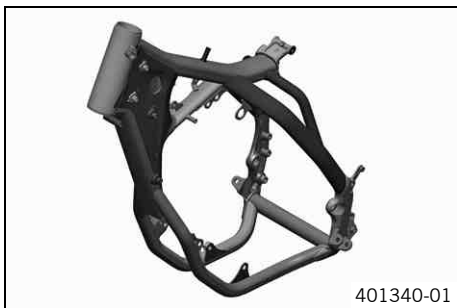

- Check the frame for cracking and deformation.
 - » If the frame exhibits cracking or deformation due to a mechanical impact:
 - Change the frame. 🛠️

i Info

A frame that has been damaged due to a mechanical impact must always be changed. Repair of the frame is not authorized by KTM.

12.42 Checking the swingarm 🛠️



- Check the swingarm for damage, cracking, and deformation.
 - » If the swingarm shows signs of damage, cracking, or deformation:
 - Change the swingarm. 🛠️

i Info

A damaged swingarm must always be changed. Repair of the swingarm is not authorized by KTM.

12.43 Checking the throttle cable routing

Preparatory work

- Remove the seat. (🔧 p. 67)
- Remove the fuel tank. 🛠️ (🔧 p. 71)



Main work

- Check the throttle cable routing.

Both throttle cables must be routed side by side behind the handlebars and above the fuel tank bearing to the throttle valve body.

- » If the throttle cable is not routed as specified:
 - Correct the throttle cable routing.

Finishing work

- Install the fuel tank. (🔧 p. 72)
- Mount the seat. (🔧 p. 68)

12.44 Checking the rubber grip

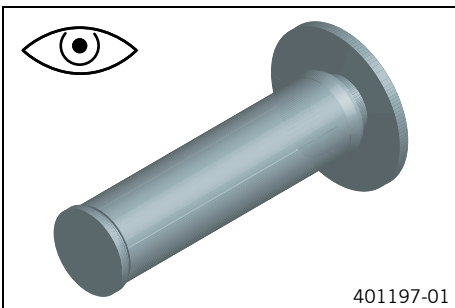

- Check the rubber grips on the handlebar for damage and wear and to ensure they are firmly seated.
 - » If a rubber grip is damaged, worn or loose:
 - Change and secure the rubber grip.

Rubber grip adhesive (00062030051) (🔧 p. 129)

12.45 Additionally securing the rubber grip

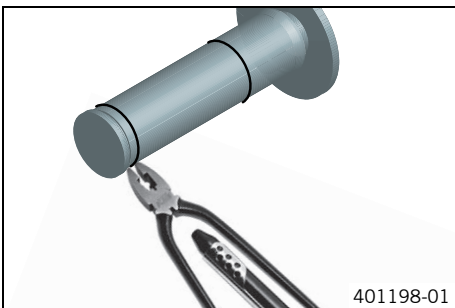

Preparatory work

- Check the rubber grip. (🔧 p. 78)

Main work

- Secure the rubber grip at two points using the securing wire.

Securing wire (54812016000)

Wire twister forceps (U6907854)

- ✓ The twisted wire ends face away from the hands and are bent toward the rubber grip.

12.46 Adjusting the basic position of the clutch lever

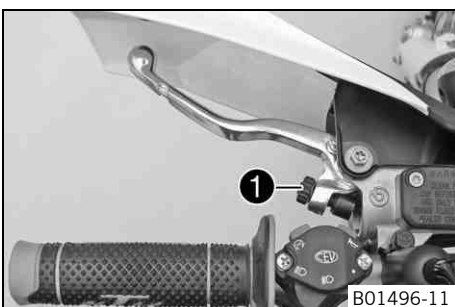

- Adjust the basic setting of the clutch lever to your hand size by turning adjusting screw ❶.

i Info

Turn the adjusting screw clockwise to increase the distance between the clutch lever and the handlebar.
 Turn the adjusting screw counterclockwise to decrease the distance between the clutch lever and the handlebar.
 The range of adjustment is limited.
 Turn the adjusting screw by hand only, and do not apply any force.
 Do not make any adjustments while riding!

12.47 Checking/correcting the fluid level of the hydraulic clutch

i Info
The fluid level rises with increased wear of the clutch lining discs.

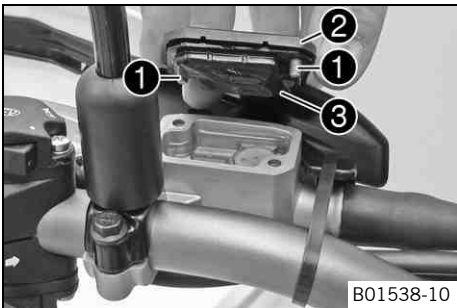

- Move the clutch fluid reservoir mounted on the handlebar to a horizontal position.
- Remove screws ❶.
- Remove cover ❷ with membrane ❸.
- Check the fluid level.

| | |
|---------------------------------|----------------|
| Fluid level below container rim | 4 mm (0.16 in) |
|---------------------------------|----------------|

- » If the fluid level does not meet specifications:
 - Correct the fluid level of the hydraulic clutch.

| |
|--|
| Brake fluid DOT 4 / DOT 5.1 (☛ p. 126) |
|--|

- Position the cover with the membrane. Mount and tighten the screws.

i Info
Clean up overflowed or spilt brake fluid immediately with water.

12.48 Changing the hydraulic clutch fluid ☞

Warning
Environmental hazard Hazardous substances cause environmental damage.

- Oil, grease, filters, fuel, cleaners, brake fluid, etc., should be disposed of as stipulated in applicable regulations.

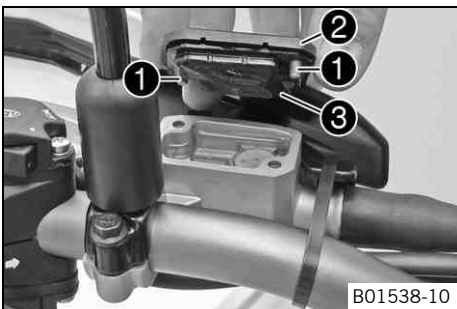

- Move the clutch fluid reservoir mounted on the handlebar to a horizontal position.
- Remove screws ❶.
- Remove cover ❷ with membrane ❸.

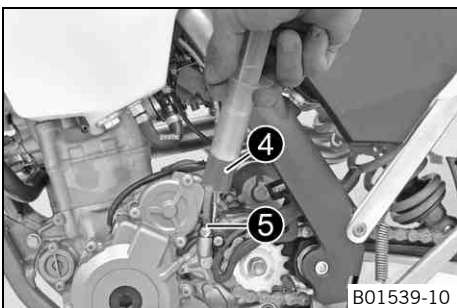

- Fill bleeding syringe ❹ with the appropriate hydraulic fluid.
- On the slave cylinder of the clutch, remove bleeder screw ❺ and mount bleeding syringe ❹.

| |
|-----------------------------|
| Bleed syringe (50329050000) |
|-----------------------------|

| |
|--|
| Brake fluid DOT 4 / DOT 5.1 (☛ p. 126) |
|--|

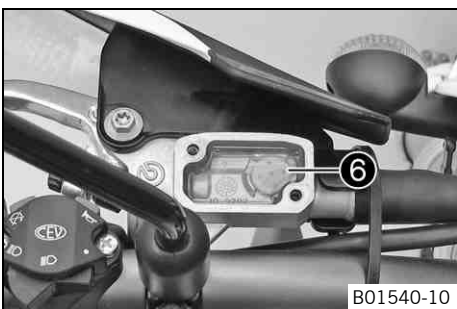

- Inject the liquid into the system until it escapes from openings ❻ of the master cylinder without bubbles.
- To prevent overflow, drain fluid occasionally from the master cylinder reservoir.
- Remove the bleeding syringe. Mount and tighten screws bleeder screw.
- Correct the fluid level of the hydraulic clutch.

Guideline

| | |
|---------------------------------|----------------|
| Fluid level below container rim | 4 mm (0.16 in) |
|---------------------------------|----------------|

- Position the cover with the membrane. Mount and tighten the screws.

12.49 Removing the engine guard (EXC-F AUS, EXC-F SIX DAYS)



- Turn quick release ❶ counterclockwise until it disengages. Remove the engine guard.

12.50 Installing the engine guard (EXC-F AUS, EXC-F SIX DAYS)



- Attach the engine guard on the frame at the rear and swing up at the front.
- Turn quick release ❶ clockwise all the way.

13.1 Checking free travel of hand brake lever

Warning
Danger of accidents Brake system failure.

- If there is no free travel on the hand brake lever, pressure builds up on the front brake circuit. The front brake can fail due to overheating. Adjust the free travel on hand brake lever according to specifications.

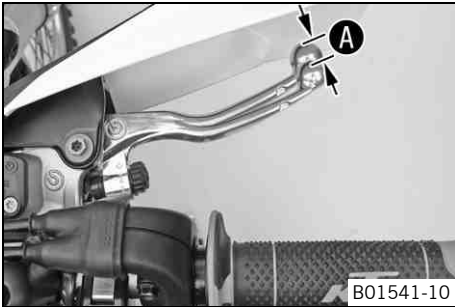

(All EXC-F models)

- Push the hand brake to the handlebar and check free travel **A**.

| | |
|---------------------------------|--------------------|
| Free travel of hand brake lever | ≥ 3 mm (≥ 0.12 in) |
|---------------------------------|--------------------|

- » If the free travel does not meet specifications:
 - Adjust the free travel of the hand brake lever. (☛ p. 81)

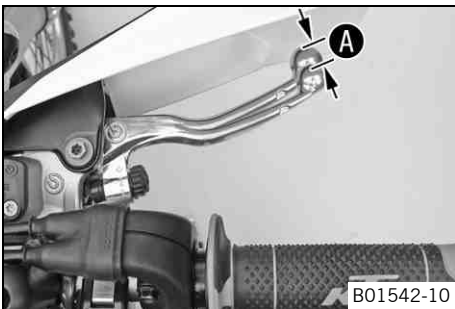

(XCF-W)

- Push the hand brake lever forwards and check free travel **A**.

| | |
|---------------------------------|--------------------|
| Free travel of hand brake lever | ≥ 3 mm (≥ 0.12 in) |
|---------------------------------|--------------------|

- » If the free travel does not meet specifications:
 - Adjust the basic position of the hand brake lever. (☛ p. 81)

13.2 Adjusting free travel of hand brake lever (All EXC-F models)



- Check the free travel of the hand brake lever. (☛ p. 81)
- Adjust the free travel of the hand brake lever with adjusting screw **1**.

i Info

Turn the adjustment screw clockwise to reduce free travel. The pressure point moves away from the handlebar.
 Turn the adjustment screw counterclockwise to increase free travel. The pressure point moves towards the handlebar.
 The range of adjustment is limited.
 Turn the adjusting screw by hand only, and do not apply any force.
 Do not make any adjustments while riding!

13.3 Adjusting the basic position of the hand brake lever (XCF-W)

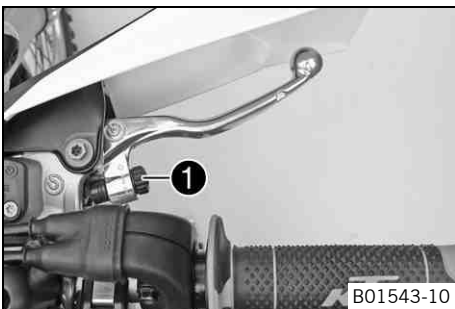

- Check the free travel of the hand brake lever. (☛ p. 81)
- Adjust the basic setting of the hand brake lever to your hand size by turning adjusting screw **1**.

i Info

Turn the adjusting screw clockwise to increase the distance between the hand brake lever and the handlebar.
 Turn the adjusting screw counterclockwise to decrease the distance between the hand brake lever and the handlebar.
 The range of adjustment is limited.
 Turn the adjusting screw by hand only, and do not apply any force.
 Do not make any adjustments while riding!

13.4 Checking the brake discs

Warning
Danger of accidents Reduced braking efficiency due to worn brake disc(s).

- Change the worn brake disc(s) without delay. (Your authorized KTM workshop will be glad to help.)

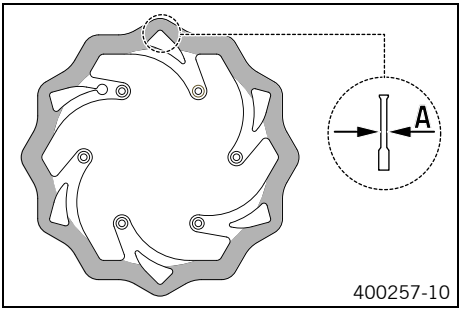

- Check the thickness of the front and rear brake discs at several places on the disk to see if it conforms to measurement **A**.

Info
 Wear reduces the thickness of the brake disc around the area used by the brake linings.

| Brake discs - wear limit | |
|--------------------------|-------------------|
| Front | 2.5 mm (0.098 in) |
| Rear | 3.5 mm (0.138 in) |

- » If the brake disc thickness is less than the specified value:
 - Change the brake disc.
- Check the front and rear brake discs for damage, cracking and deformation.
 - » If the brake disc shows signs of damage, cracking, or deformation:
 - Change the brake disc.

13.5 Checking the brake fluid level of the front brake

Warning
Danger of accidents Brake system failure.

- If the brake fluid level drops below the specified marking or the specified value, this is an indication that the brake system is leaking or that the brake linings are completely worn down. Check the brake system and do not continue riding. (Your authorized KTM workshop will be glad to help.)

Warning
Danger of accidents Reduced braking efficiency due to old brake fluid.

- Change the brake fluid of the front and rear brake according to the service schedule. (Your authorized KTM workshop will be glad to help.)

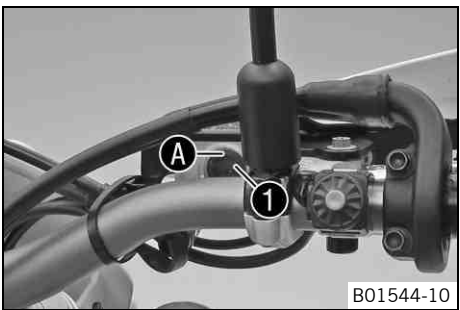

- Move the brake fluid reservoir mounted on the handlebar to a horizontal position.
- Check the brake fluid level in level viewer **1**.
 - » If the brake fluid level has dropped below marking **A**:
 - Add front brake fluid. 🛠️ (📖 p. 82)

13.6 Adding front brake fluid 🛠️

Warning
Danger of accidents Brake system failure.

- If the brake fluid level drops below the specified marking or the specified value, this is an indication that the brake system is leaking or that the brake linings are completely worn down. Check the brake system and do not continue riding. (Your authorized KTM workshop will be glad to help.)

Warning
Skin irritation Brake fluid can cause skin irritation on contact.

- Avoid contact with skin and eyes, and keep out of the reach of children.
- Wear suitable protective clothing and goggles.
- If brake fluid comes into contact with the eyes, flush the eyes thoroughly with water and consult a physician immediately.

- Warning**
Danger of accidents Reduced braking efficiency due to old brake fluid.
- Change the brake fluid of the front and rear brake according to the service schedule. (Your authorized KTM workshop will be glad to help.)

- Warning**
Environmental hazard Hazardous substances cause environmental damage.
- Oil, grease, filters, fuel, cleaners, brake fluid, etc., should be disposed of as stipulated in applicable regulations.

i Info
 Never use DOT 5 brake fluid. It is silicone-based and purple in color. Oil seals and brake lines are not designed for DOT 5 brake fluid.
 Avoid contact between brake fluid and painted parts. Brake fluid attacks paint!
 Use only clean brake fluid from a sealed container.

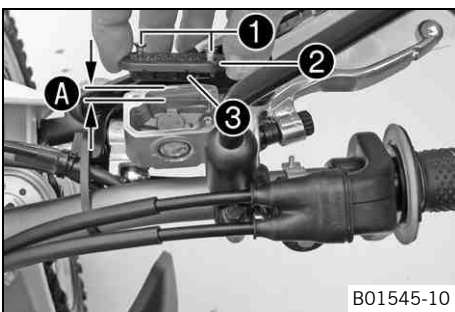

Preparatory work

- Check the front brake linings. (☞ p. 83)

Main work

- Move the brake fluid reservoir mounted on the handlebar to a horizontal position.
- Remove screws 1.
- Remove cover 2 with membrane 3.
- Add brake fluid to level A.

Guideline

| | |
|---|---------------|
| Level A (brake fluid level below container rim) | 5 mm (0.2 in) |
|---|---------------|

Brake fluid DOT 4 / DOT 5.1 (☞ p. 126)

- Position the cover with the membrane. Mount and tighten the screws.

i Info
 Clean up overflowed or spilt brake fluid immediately with water.

13.7 Checking the front brake linings

- Warning**
Danger of accidents Reduced braking efficiency caused by worn brake linings.
- Change worn brake linings immediately. (Your authorized KTM workshop will be glad to help.)

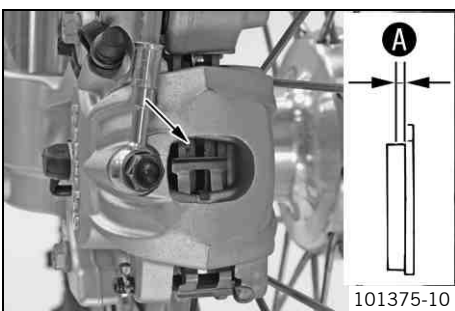

- Check the brake linings for minimum thickness A.

| | |
|---------------------|--------------------|
| Minimum thickness A | ≥ 1 mm (≥ 0.04 in) |
|---------------------|--------------------|

- » If the minimum thickness is less than specified:
 - Change the front brake linings. ☞ (☞ p. 84)
- Check the brake linings for damage and cracking.
 - » If damage or cracking is visible:
 - Change the front brake linings. ☞ (☞ p. 84)

13.8 Changing the front brake linings

- Warning**
Danger of accident Brake system failure.
 - Maintenance work and repairs must be carried out professionally. (Your authorized KTM workshop will be glad to help.)
- Warning**
Skin irritation Brake fluid can cause skin irritation on contact.
 - Avoid contact with skin and eyes, and keep out of the reach of children.
 - Wear suitable protective clothing and goggles.
 - If brake fluid comes into contact with the eyes, flush the eyes thoroughly with water and consult a physician immediately.
- Warning**
Danger of accidents Reduced braking efficiency due to old brake fluid.
 - Change the brake fluid of the front and rear brake according to the service schedule. (Your authorized KTM workshop will be glad to help.)
- Warning**
Danger of accidents Reduced braking efficiency due to oil or grease on the brake discs.
 - Always keep the brake discs free of oil and grease, and clean them with brake cleaner when necessary.
- Warning**
Danger of accidents Reduced braking efficiency due to use of non-approved brake linings.
 - Brake linings available from accessory suppliers are often not tested and approved for use on KTM vehicles. The construction and friction factor of the brake linings and therefore the brake power can differ considerably from the original KTM brake linings. If brake linings are used that differ from the originals, there is no guarantee that they comply with the original license. The vehicle no longer corresponds to the condition at delivery, and the warranty is no longer valid.
-  **Warning**
Environmental hazard Hazardous substances cause environmental damage.
 - Oil, grease, filters, fuel, cleaners, brake fluid, etc., should be disposed of as stipulated in applicable regulations.

i Info
 Never use DOT 5 brake fluid! This is based on silicone oil and is colored purple. Oil seals and brake lines are not designed for DOT 5 brake fluid.
 Avoid contact between brake fluid and painted parts. Brake fluid attacks paint!
 Use only clean brake fluid from a sealed container.

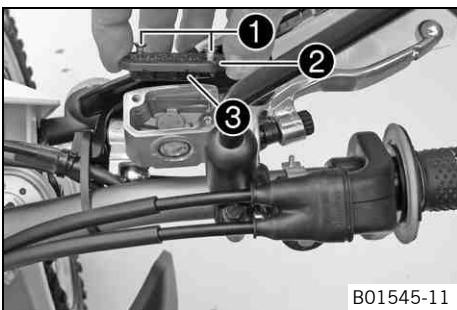

- Move the brake fluid reservoir mounted on the handlebar to a horizontal position.
- Remove screws **1**.
- Remove cover **2** with membrane **3**.
- Manually press the brake caliper toward the brake disc to push back the brake pistons. Ensure that brake fluid does not flow out of the brake fluid reservoir, extracting it by suction if it does.

i Info
 Make sure when pushing back the brake pistons that you do not press the brake caliper against the spokes.

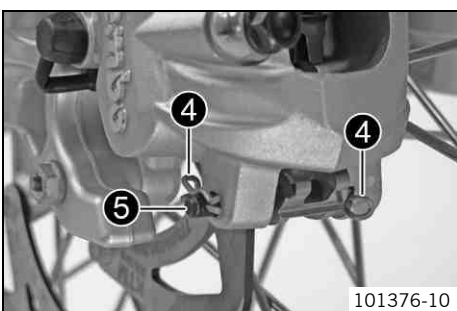

- Remove cotter pin **4**, pull out pin **5**, and remove the brake linings.
- Clean the brake caliper and brake caliper support.

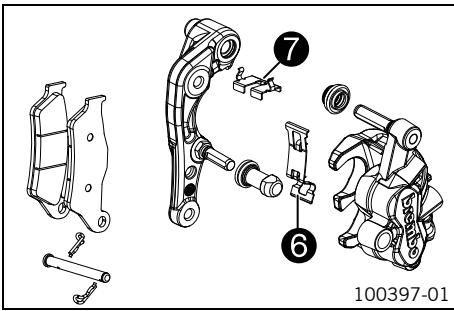

- Check that leaf spring 6 in the brake caliper and sliding plate 7 in the brake caliper support are seated correctly.

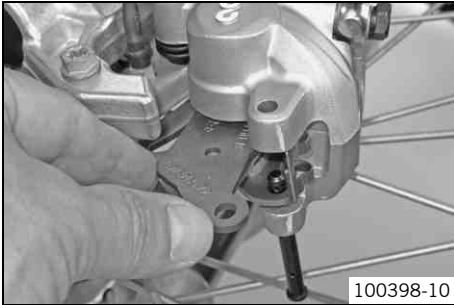

- Insert the brake linings, insert the pin, and mount the cotter pin.
- Operate the hand brake lever repeatedly until the brake linings are in contact with the brake disc and there is a pressure point.

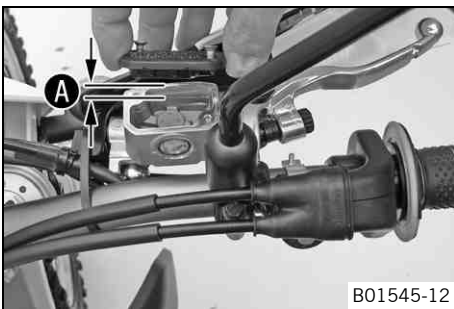

- Correct the brake fluid quantity to level A.

Guideline

| | |
|---|---------------|
| Dimension A (brake fluid level below top edge of container) | 5 mm (0.2 in) |
|---|---------------|

| |
|--|
| Brake fluid DOT 4 / DOT 5.1 (↖ p. 126) |
|--|

- Position the cover with the membrane. Mount and tighten the screws.

Info
Clean up overflowed or spilt brake fluid immediately with water.

13.9 Checking the free travel of foot brake lever

Warning
Danger of accidents Brake system failure.

- If there is no free travel on the foot brake lever, pressure builds up on the rear brake circuit. The rear brake can fail due to overheating. Adjust the free travel on foot brake lever according to specifications.

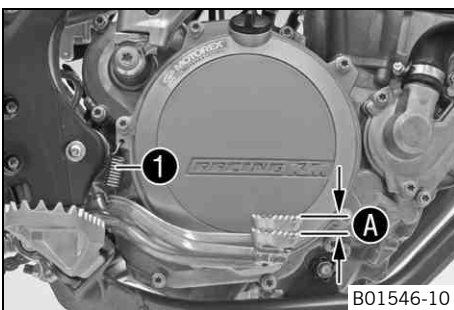

- Disconnect spring 1.
- Move the foot brake lever back and forth between the end stop and the contact to the foot brake cylinder piston and check free travel A.

Guideline

| | |
|---------------------------------|----------------------------|
| Free travel at foot brake lever | 3... 5 mm (0.12... 0.2 in) |
|---------------------------------|----------------------------|

- » If the free travel does not meet specifications:
 - Adjust the basic position of the foot brake lever. ↘ (↖ p. 85)
- Reconnect spring 1.

13.10 Adjusting the basic position of the foot brake lever ↘

Warning
Danger of accidents Brake system failure.

- If there is no free travel on the foot brake lever, pressure builds up on the rear brake circuit. The rear brake can fail due to overheating. Adjust the free travel on foot brake lever according to specifications.

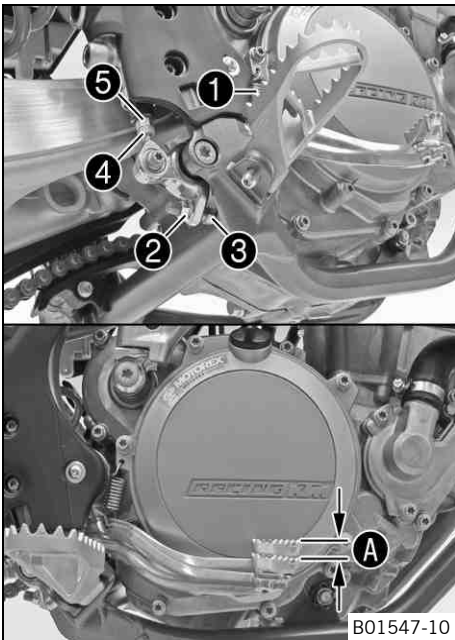

- Disconnect spring ❶.
- Loosen nut ❷ and, with push rod ❸, turn it back until you have maximum free travel.
- To adjust the basic position of the foot brake lever individually, loosen nut ❹ and turn screw ❺ accordingly.

Info
The range of adjustment is limited.

- Turn push rod ❸ accordingly until you have free travel A. If necessary, adjust the basic position of the foot brake lever.

Guideline

| | |
|---------------------------------|----------------------------|
| Free travel at foot brake lever | 3... 5 mm (0.12... 0.2 in) |
|---------------------------------|----------------------------|

- Hold screw ❺ and tighten nut ❹.

Guideline

| | | |
|----------------------------|----|---------------------|
| Nut, foot brake lever stop | M8 | 20 Nm (14.8 lbf ft) |
|----------------------------|----|---------------------|

- Hold push rod ❸ and tighten nut ❷.

Guideline

| | | |
|-------------------------|----|--------------------|
| Remaining nuts, chassis | M6 | 10 Nm (7.4 lbf ft) |
|-------------------------|----|--------------------|

- Reconnect spring ❶.

13.11 Checking the rear brake fluid level

Warning
Danger of accidents Brake system failure.

- If the brake fluid level drops below the specified marking or the specified value, this is an indication that the brake system is leaking or that the brake linings are completely worn down. Check the brake system and do not continue riding. (Your authorized KTM workshop will be glad to help.)

Warning
Danger of accidents Reduced braking efficiency due to old brake fluid.

- Change the brake fluid of the front and rear brake according to the service schedule. (Your authorized KTM workshop will be glad to help.)

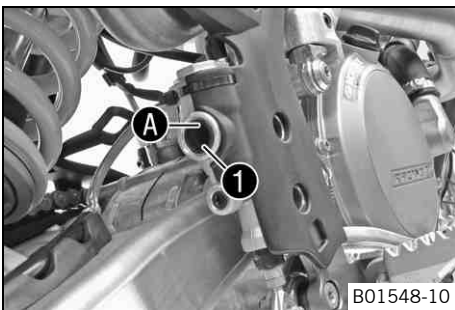

- Stand the vehicle upright.
- Check the brake fluid level in level viewer ❶.
 - » If the brake fluid level has dropped below marking A:
 - Add rear brake fluid. (p. 86)

13.12 Adding rear brake fluid

Warning
Danger of accidents Brake system failure.

- If the brake fluid level drops below the specified marking or the specified value, this is an indication that the brake system is leaking or that the brake linings are completely worn down. Check the brake system and do not continue riding. (Your authorized KTM workshop will be glad to help.)

Warning
Skin irritation Brake fluid can cause skin irritation on contact.

- Avoid contact with skin and eyes, and keep out of the reach of children.
- Wear suitable protective clothing and goggles.
- If brake fluid comes into contact with the eyes, flush the eyes thoroughly with water and consult a physician immediately.

- Warning**
Danger of accidents Reduced braking efficiency due to old brake fluid.
- Change the brake fluid of the front and rear brake according to the service schedule. (Your authorized KTM workshop will be glad to help.)

- Warning**
Environmental hazard Hazardous substances cause environmental damage.
- Oil, grease, filters, fuel, cleaners, brake fluid, etc., should be disposed of as stipulated in applicable regulations.

i Info
 Never use DOT 5 brake fluid. It is silicone-based and purple in color. Oil seals and brake lines are not designed for DOT 5 brake fluid.
 Avoid contact between brake fluid and painted parts. Brake fluid attacks paint!
 Use only clean brake fluid from a sealed container.

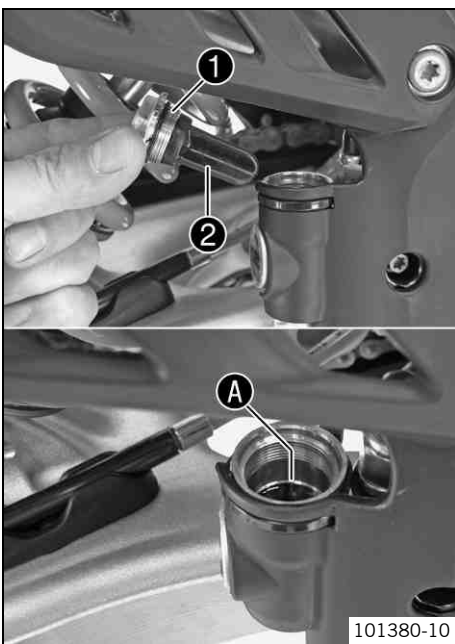

Preparatory work

- Check the rear brake linings. (☛ p. 87)

Main work

- Stand the vehicle upright.
- Remove screw cap ❶ with membrane ❷ and the O-ring.
- Add brake fluid to level A.

| |
|--|
| Brake fluid DOT 4 / DOT 5.1 (☛ p. 126) |
|--|

- Mount the screw cap with the membrane and the O-ring.

i Info
 Clean up overflowed or spilt brake fluid immediately with water.

13.13 Checking the rear brake linings

- Warning**
Danger of accidents Reduced braking efficiency caused by worn brake linings.

- Change worn brake linings immediately. (Your authorized KTM workshop will be glad to help.)

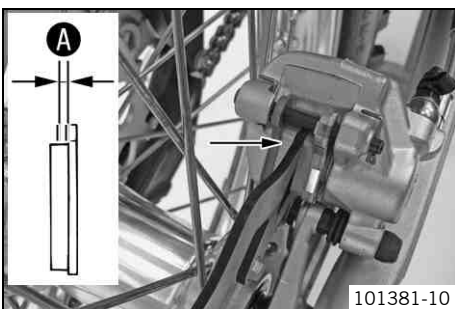

- Check the brake linings for minimum thickness A.

| | |
|---------------------|--------------------|
| Minimum thickness A | ≥ 1 mm (≥ 0.04 in) |
|---------------------|--------------------|

- » If the minimum thickness is less than specified:
 - Change the rear brake linings. ☛ (☛ p. 88)
- Check the brake linings for damage and cracking.
 - » If damage or cracking is visible:
 - Change the rear brake linings. ☛ (☛ p. 88)

13.14 Changing the rear brake linings

- Warning**
Danger of accident Brake system failure.
 - Maintenance work and repairs must be carried out professionally. (Your authorized KTM workshop will be glad to help.)
- Warning**
Skin irritation Brake fluid can cause skin irritation on contact.
 - Avoid contact with skin and eyes, and keep out of the reach of children.
 - Wear suitable protective clothing and goggles.
 - If brake fluid comes into contact with the eyes, flush the eyes thoroughly with water and consult a physician immediately.
- Warning**
Danger of accidents Reduced braking efficiency due to old brake fluid.
 - Change the brake fluid of the front and rear brake according to the service schedule. (Your authorized KTM workshop will be glad to help.)
- Warning**
Danger of accidents Reduced braking efficiency due to oil or grease on the brake discs.
 - Always keep the brake discs free of oil and grease, and clean them with brake cleaner when necessary.
- Warning**
Danger of accidents Reduced braking efficiency due to use of non-approved brake linings.
 - Brake linings available from accessory suppliers are often not tested and approved for use on KTM vehicles. The construction and friction factor of the brake linings and therefore the brake power can differ considerably from the original KTM brake linings. If brake linings are used that differ from the originals, there is no guarantee that they comply with the original license. The vehicle no longer corresponds to the condition at delivery, and the warranty is no longer valid.
- Warning**
Environmental hazard Hazardous substances cause environmental damage.
 - Oil, grease, filters, fuel, cleaners, brake fluid, etc., should be disposed of as stipulated in applicable regulations.

i Info
Never use DOT 5 brake fluid! This is based on silicone oil and is colored purple. Oil seals and brake lines are not designed for DOT 5 brake fluid.
Avoid contact between brake fluid and painted parts. Brake fluid attacks paint!
Use only clean brake fluid from a sealed container.

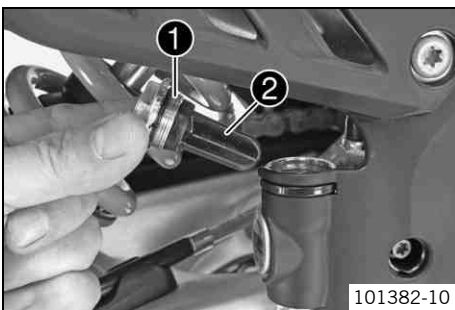

- Stand the vehicle upright.
- Remove screw cap ① with membrane ② and the O-ring.
- Press the brake piston back to its basic position and make sure that no brake fluid overflows from the brake fluid reservoir.

i Info
Make sure when pushing back the brake piston that you do not press the brake caliper against the spokes.

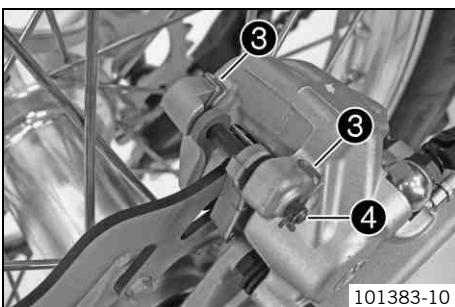

- Remove cotter pin ③, pull out pin ④, and remove the brake linings.
- Clean the brake caliper and brake caliper support.

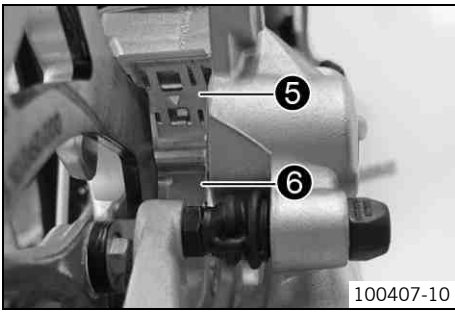

100407-10

- Check that leaf spring ⑤ in the brake caliper and sliding plate ⑥ in the brake caliper support are seated correctly.

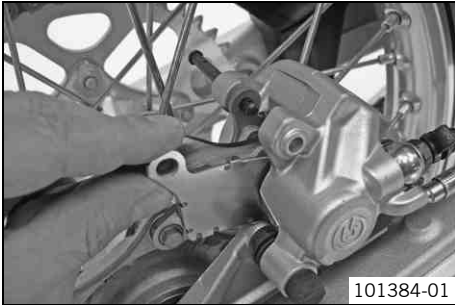

101384-01

- Insert the brake linings, insert the pin, and mount the cotter pin.
- Operate the foot brake lever repeatedly until the brake linings are in contact with the brake disc and there is a pressure point.

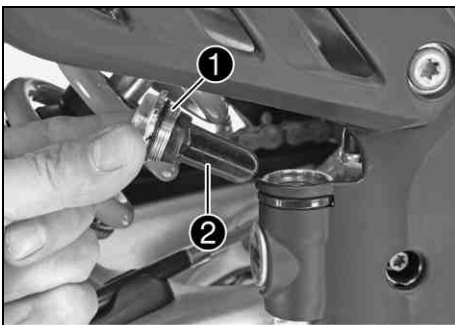

- Add brake fluid to level A.

Brake fluid DOT 4 / DOT 5.1 (☛ p. 126)

- Mount screw cap ① with membrane ② and the O-ring.

i Info

Clean up overflowed or spilt brake fluid immediately with water.

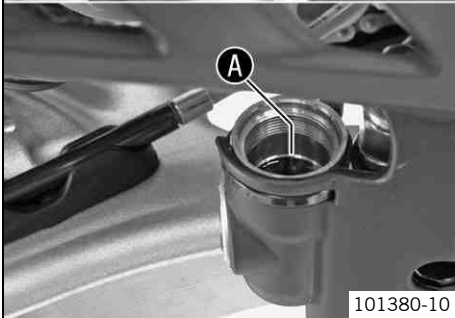

101380-10

14.1 Removing the front wheel



Preparatory work

- Raise the motorcycle with the lift stand. (☛ p. 56)

Main work

- Press the brake caliper onto the brake disc by hand in order to push back the brake pistons.

i Info

Make sure when pushing back the brake pistons that you do not press the brake caliper against the spokes.

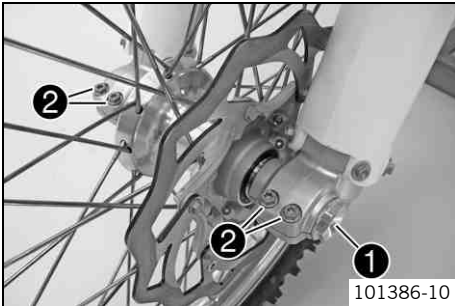

- Remove screw ❶.
- Release screws ❷.

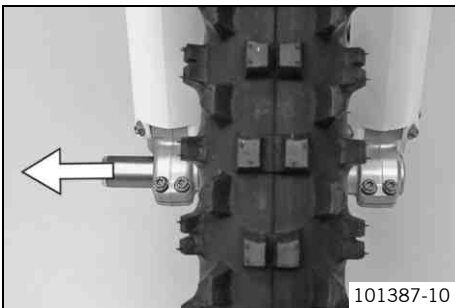

- Holding the front wheel, withdraw the wheel spindle. Take the front wheel out of the fork.

i Info

Do not pull the hand brake lever when the front wheel is removed. Always lay the wheel down in such a way that the brake disc is not damaged.

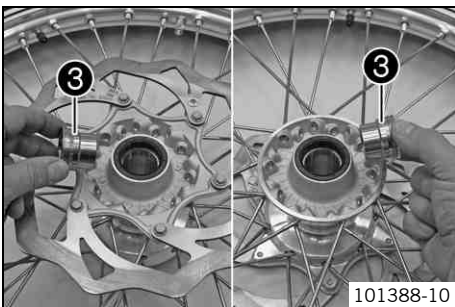

- Remove spacers ❸.

14.2 Installing the front wheel



Warning

Danger of accidents Reduced braking efficiency due to oil or grease on the brake discs.

- Always keep the brake discs free of oil and grease, and clean them with brake cleaner when necessary.

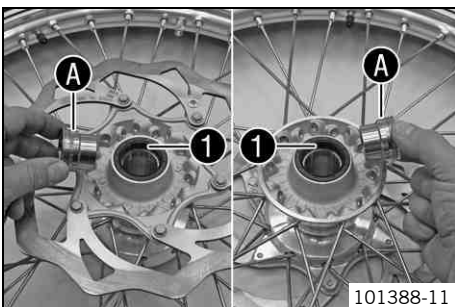

- Check the wheel bearing for damage and wear.
 - » If the wheel bearing is damaged or worn:
 - Change the wheel bearing. ☛
- Clean and grease shaft seal rings ❶ and bearing surface **A** of the spacers.

Long-life grease (☛ p. 128)

- Insert the spacers.

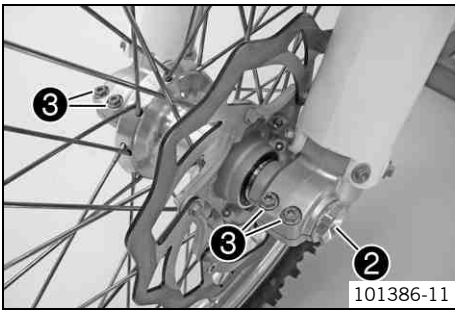

- Position the front wheel and insert the wheel spindle.
 ✓ The brake linings are correctly positioned.
- Mount and tighten screw ②.

Guideline

| | | |
|----------------------------|---------|------------------------|
| Screw, front wheel spindle | M24x1.5 | 45 Nm (33.2 lbf ft) |
|----------------------------|---------|------------------------|

- Activate the hand brake lever multiple times until the brake linings are in contact with the brake disc.
- Remove the motorcycle from the lift stand. (☛ p. 56)
- Pull the front wheel brake and push down hard on the fork several times to align the fork legs.
- Fully tighten screw ③.

Guideline

| | | |
|------------------|----|------------------------|
| Screw, fork stub | M8 | 15 Nm (11.1 lbf ft) |
|------------------|----|------------------------|

14.3 Removing the rear wheel 🛠️

Preparatory work

- Raise the motorcycle with the lift stand. (☛ p. 56)

Main work

- Press the brake caliper by hand on to the brake disc in order to press back the brake piston.

i Info
 Make sure when pushing back the brake piston that you do not press the brake caliper against the spokes.

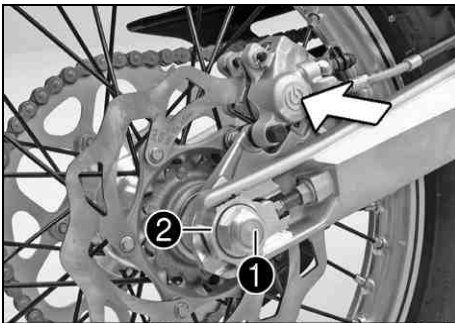

- Remove nut ①.
- Remove chain adjuster ②. Withdraw wheel spindle ③ only enough to allow the rear wheel to be pushed forward.
- Push the rear wheel forward as far as possible. Remove the chain from the rear sprocket.
- Holding the rear wheel, withdraw the wheel spindle. Take the rear wheel out of the swingarm.

i Info
 Do not operate the foot brake when the rear wheel is removed.
 Always lay the wheel down in such a way that the brake disc is not damaged.

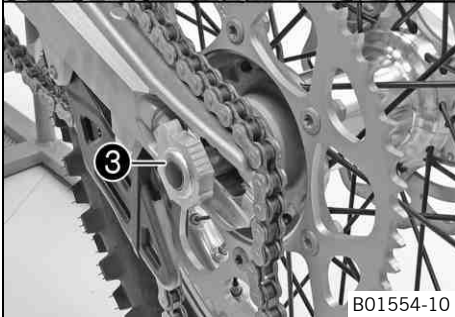

- Remove spacers ④.

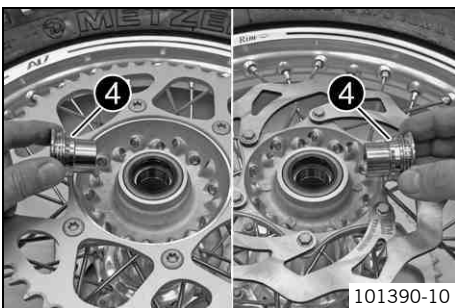

14.4 Installing the rear wheel

Warning
Danger of accidents Reduced braking efficiency due to oil or grease on the brake discs.
 – Always keep the brake discs free of oil and grease, and clean them with brake cleaner when necessary.

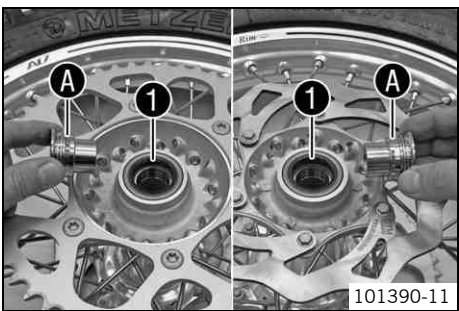

101390-11

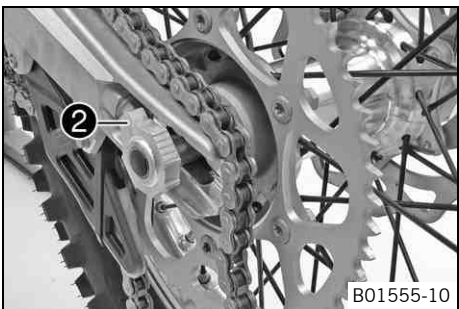

B01555-10

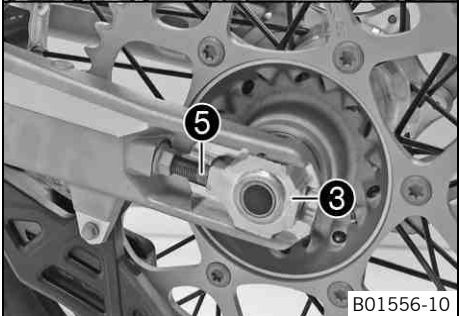
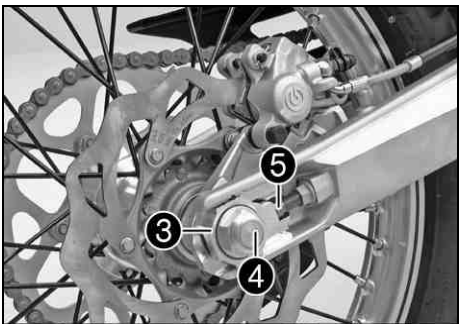

B01556-10

Main work

- Check the wheel bearing for damage and wear.
 - » If the wheel bearing is damaged or worn:
 - Change the wheel bearing.
- Clean and grease shaft seal rings 1 and bearing surface A of the spacers.

Long-life grease (p. 128)

- Insert the spacers.
- Position the rear wheel and insert wheel spindle 2.
 - ✓ The brake linings are correctly positioned.
- Attach the chain.

- Position chain adjuster 3. Mount nut 4 but do not tighten it yet.
- Make sure that chain adjusters 3 are fitted correctly on adjusting screws 5.
- Check the chain tension. (p. 74)
- Tighten nut 4.

Guideline

| | | |
|-------------------------|---------|-------------------|
| Nut, rear wheel spindle | M20x1.5 | 80 Nm (59 lbf ft) |
|-------------------------|---------|-------------------|

i Info
 The wide adjustment range of the chain adjusters (32 mm (1.26 in)) enables different secondary ratios with the same chain length. Chain adjusters 3 can be turned by 180°.

- Operate the foot brake lever repeatedly until the brake linings are in contact with the brake disc and there is a pressure point.

Finishing work

- Remove the motorcycle from the lift stand. (p. 56)

14.5 Checking the tire condition

i Info
 Only mount tires approved and/or recommended by KTM. Other tires could have a negative effect on handling characteristics. The type, condition, and air pressure of the tires all have a significant impact on the handling characteristics of the motorcycle. The tires mounted on the front and rear wheels must have a similar profile. Worn tires have a negative effect on handling characteristics, especially on wet surfaces.

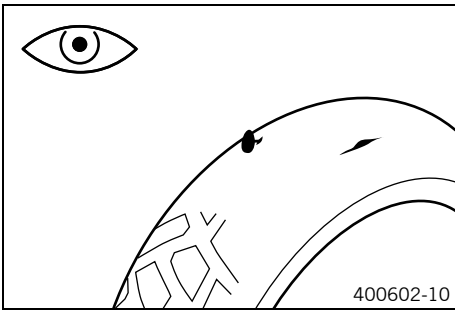

- Check the front and rear tires for cuts, run-in objects, and other damage.
 - » If the tire exhibits cuts, run-in objects, or other damage:
 - Change the tire.
- Check the depth of the tread.



Info

Note local national regulations concerning the minimum tread depth.

| | |
|---------------------|--------------------|
| Minimum tread depth | ≥ 2 mm (≥ 0.08 in) |
|---------------------|--------------------|

- » If the tread depth is less than the minimum permissible depth:
 - Change the tire.
- Check the tire age.



Info

The tire's date of manufacture is usually part of the tire markings and is indicated by the last four digits of the **DOT** marking. The first two digits indicate the week of manufacture and the last two digits the year of manufacture.

KTM recommends that the tires be changed after 5 years at the latest, regardless of the actual state of wear.

- » If the tire is older than five years:
 - Change the tire.

14.6 Checking the tire air pressure



Info

Low tire air pressure leads to abnormal wear and overheating of the tire. Correct tire air pressure ensures optimal riding comfort and maximum tire service life.

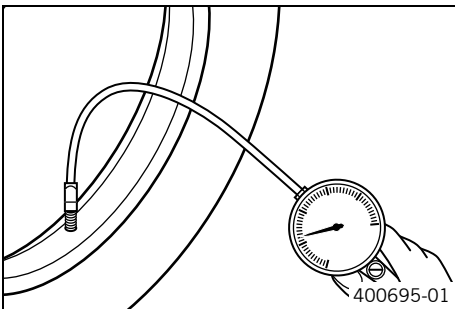

- Remove the protection cap.
- Check the tire air pressure when the tires are cold.

| Tire air pressure off road | |
|----------------------------|------------------|
| Front | 1.0 bar (15 psi) |
| Rear | 1.0 bar (15 psi) |

| Road tire pressure (All EXC-F models) | |
|---------------------------------------|------------------|
| Front | 1.5 bar (22 psi) |
| Rear | 1.5 bar (22 psi) |

- » If the tire air pressure does not meet specifications:
 - Correct the tire air pressure.
- Mount protection cap.

14.7 Checking spoke tension



Warning

Danger of accidents Instable handling due to incorrect spoke tension.

- Ensure that the spoke tension is correct. (Your authorized KTM workshop will be glad to help.)



Info

A loose spoke can cause wheel imbalance, which leads to more loose spokes in a short time. If the spokes are too tight, they can break due to local overload. Check the spoke tension regularly, especially on a new motorcycle.

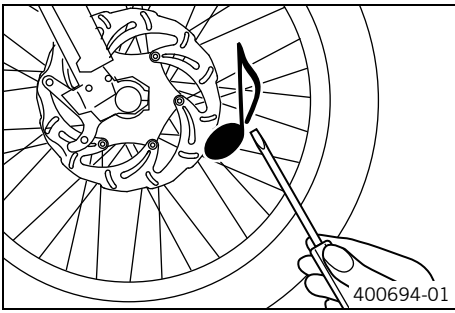

- Tap each spoke with a screwdriver.

i Info

The sound frequency depends on the length and thickness of the spoke. If there are different sound frequencies in spokes with the same length and thickness, this indicates different spoke tensions.

You should hear a high note.

- » If the spoke tension varies:
 - Correct the spoke tension. ↩

- Check the spoke torque.

Guideline

| | | |
|---------------------------|------|-------------------------------|
| Spoke nipple, front wheel | M4.5 | 5... 6 Nm (3.7... 4.4 lbf ft) |
| Spoke nipple, rear wheel | M4.5 | 5... 6 Nm (3.7... 4.4 lbf ft) |

Torque wrench with various accessories in set (58429094000)

15.1 Removing the battery

- Warning**
Risk of injury Battery acid and battery gases cause serious chemical burns.
- Keep batteries out of the reach of children.
 - Wear suitable protective clothing and goggles.
 - Avoid contact with battery acid and battery gases.
 - Keep sparks and open flames away from the battery. Only charge in well-ventilated rooms.
 - In the event of skin contact, rinse with large amounts of water. If battery acid gets in the eyes, rinse with water for at least 15 minutes and contact a physician.

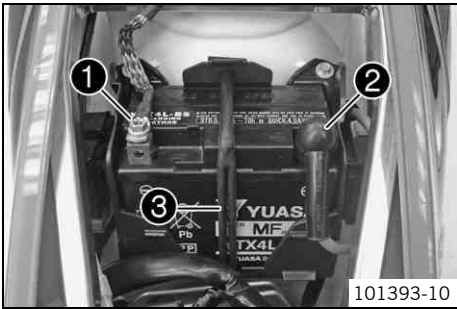

- Preparatory work**
- Switch off all power consumers and switch off the engine.
 - Remove the seat. (☛ p. 67)
- Main work**
- Disconnect negative cable ① of the battery.
 - Pull back the positive terminal cover ② and disconnect the positive (plus) cable of the battery.
 - Detach rubber band ③ at the bottom.
 - Lift the battery up and out.

15.2 Installing the battery

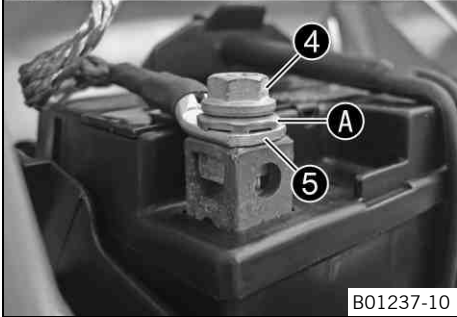
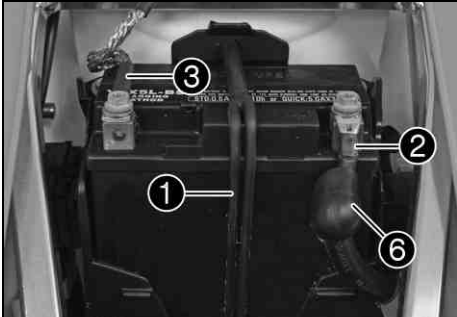

- Main work**
- Insert battery into the battery compartment with the terminals facing to the front.
- | | | |
|-------------------------------|--|--|
| Battery (YTX4L-BS) (☛ p. 122) | | |
|-------------------------------|--|--|
- Reconnect rubber band ①.
 - Connect positive cable ②.
- Guideline
- | | | |
|-------------------------|----|-------------------------|
| Screw, battery terminal | M5 | 2.5 Nm (1.84 lbf ft) |
|-------------------------|----|-------------------------|

Info
 Contact disk **A** must be mounted between screw ④ and cable socket ⑤ with the claws facing down.

- Slide positive terminal cover ⑥ over the positive terminal.
 - Connect negative cable ③.
- Guideline
- | | | |
|-------------------------|----|-------------------------|
| Screw, battery terminal | M5 | 2.5 Nm (1.84 lbf ft) |
|-------------------------|----|-------------------------|

Info
 Contact disk **A** must be mounted between screw ④ and cable socket ⑤ with the claws facing down.

- Finishing work**
- Mount the seat. (☛ p. 68)

15.3 Charging the battery

Warning
Risk of injury Battery acid and battery gases cause serious chemical burns.

- Keep batteries out of the reach of children.
- Wear suitable protective clothing and goggles.
- Avoid contact with battery acid and battery gases.
- Keep sparks and open flames away from the battery. Only charge in well-ventilated rooms.
- In the event of skin contact, rinse with large amounts of water. If battery acid gets in the eyes, rinse with water for at least 15 minutes and contact a physician.

Warning
Environmental hazard The battery contains elements that are harmful to the environment.

- Do not discard batteries with the household waste. Dispose of faulty batteries in an environmentally compatible manner. Give the battery to your authorized KTM dealer or dispose of it at a collection point for used batteries.

Warning
Environmental hazard Hazardous substances cause environmental damage.

- Oil, grease, filters, fuel, cleaners, brake fluid, etc., should be disposed of as stipulated in applicable regulations.

i Info
 Even when there is no load on the battery, it still loses power steadily. The charge state and the type of charge are very important for the service life of the battery. Rapid recharging with a high charging current shortens the battery's service life. If the charging current, charging voltage and charging time are exceeded, electrolyte escapes through the safety valves. This reduces the battery capacity. If the battery is depleted from starting the vehicle repeatedly, the battery must be charged immediately. If the battery is left in a discharged state for an extended period, it will become over-discharged and sulfate, destroying the battery. The battery is maintenance-free, which means that the acid level does not need to be checked.

Preparatory work

- Switch off all power consumers and switch off the engine.
- Remove the seat. ( p. 67)
- Disconnect the negative cable of the battery to avoid damage to the onboard electronics.

Main work

- Connect the battery charger to the battery. Switch on the battery charger.

Battery charger (58429074000)

You can also use the battery charger to test the open-circuit voltage and starting voltage of the battery, and to test the alternator. With this device, you cannot over-charge the battery.

i Info
 Never remove lid **1**. Charge the battery with a maximum of 10% of the capacity specified on battery housing **2**.

- Switch off the battery charger after charging. Disconnect the battery.

Guideline

| | |
|---|----------|
| The charge current, charge voltage, and charge time must not be exceeded. | |
| Charge the battery regularly when the motorcycle is not in use | 3 months |

Finishing work

- Mount the seat. ( p. 68)



15.4 Changing the main fuse

Warning
Fire hazard The electrical system can be overloaded if the wrong fuses are used.
 – Use only fuses with the prescribed amperage. Never by-pass or repair fuses.

Info
 The main fuse protects all power consumers of the vehicle. It is located in the starter relay housing under the air filter box cover.

Preparatory work

- Switch off all power consumers and the engine.
- Remove the air filter box lid. (☛ p. 68)

Main work

- Remove screw ❶.

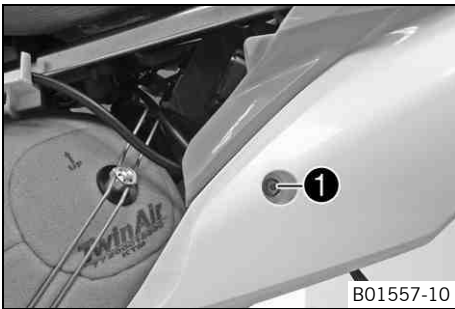

B01557-10

- Lift rear fairing ❷ slightly and pull starter relay ❸ out of the holder.

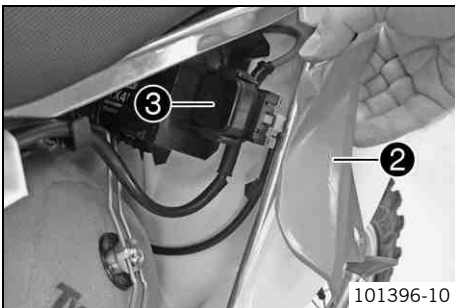

101396-10

- Remove protection caps ❹.
- Remove the faulty main fuse ❺.

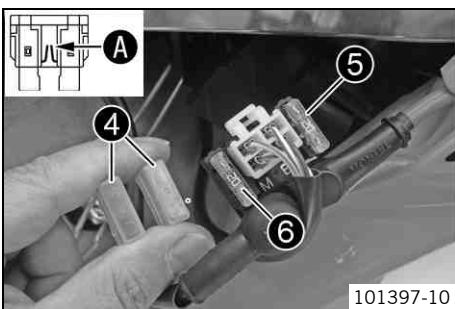

101397-10

Info

A defective fuse can be identified by the burned-out fuse wire ❹. A reserve fuse ❻ is located in the starter relay.

- Install a new main fuse.

| |
|-------------------------------|
| Fuse (58011109120) (☛ p. 122) |
|-------------------------------|

- Check that the electrical equipment is functioning properly.

Tip

Insert the spare fuse so that it is available if needed.

- Mount the protection caps.
- Mount the starter relay onto the holder and lay the cable.
- Position the rear fairing. Mount and tighten the screw.

Guideline

| | | |
|---------------------------|----|--------------------|
| Remaining screws, chassis | M6 | 10 Nm (7.4 lbf ft) |
|---------------------------|----|--------------------|

Finishing work

- Install the air filter box lid. (☛ p. 68)

15.5 Changing the fuses of individual power consumers

i Info
The fuse box containing the fuses of individual power consumers is located under the seat.

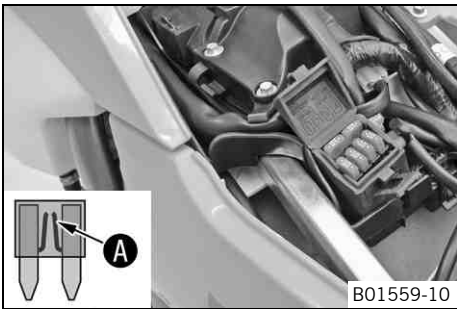
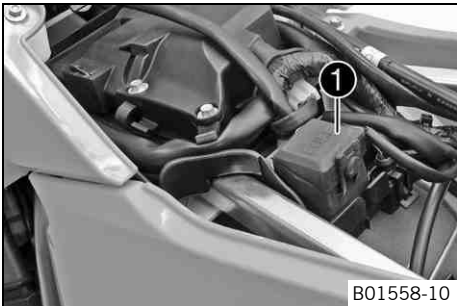

Preparatory work

- Switch off all power consumers and switch off the engine.
- Remove the seat. (☛ p. 67)

Main work

- Open fuse box cover ❶.

- Remove the defective fuse.

Guideline

| |
|--|
| Fuse 1 - 10 A - EFI control unit |
| Fuse 2 - 10 A - fuel pump |
| Fuse 3 - 10 A - high beam, low beam, parking light, tail light, license plate lamp |
| Fuse 4 - 10 A - horn, brake light, turn signal, radiator fan (optional) |
| Fuses res - 10 A - spare fuses |

i Info
A defective fuse can be identified by the burned-out fuse wire ❸.

! Warning
Fire hazard The electrical system can be overloaded if the wrong fuses are used.

- Use only fuses with the prescribed amperage. Never by-pass or repair fuses.

- Use spare fuses with the correct rating only.

| |
|-------------------------------|
| Fuse (75011088010) (☛ p. 122) |
|-------------------------------|

i Tip
Replace the spare fuse in the fuse box so that it is available if needed.

- Check that the power consumer is functioning properly.
- Close the fuse box cover.

Finishing work

- Mount the seat. (☛ p. 68)

15.6 Removing headlight mask with headlight

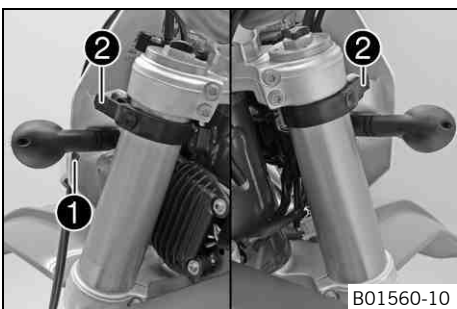

- Switch off all electrical equipment.
- Remove screw ❶ and take off clamp.
- Loosen the rubber band ❷. Push up the headlight mask and swing it forwards.

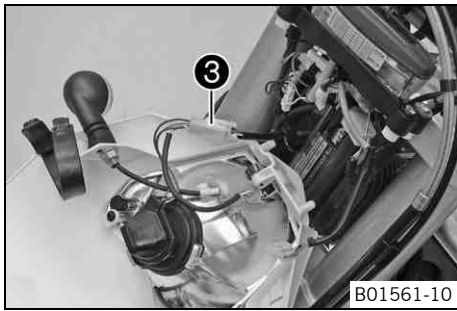

- Pull out the electric plug connector ③ and remove the headlight mask with the headlight.

15.7 Refitting the headlight mask with the headlight

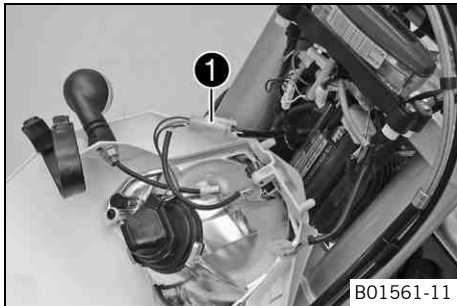

Main work

- Connect the electric plug connector ①.

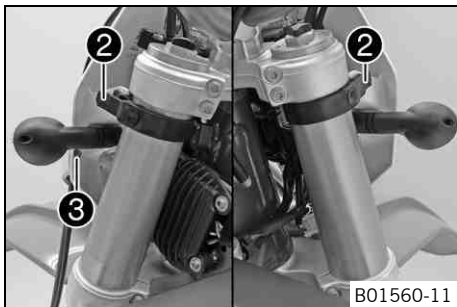

- Position the headlight mask and fix it with the rubber band ②.



Info

Ensure that the retaining lugs engage in the fender.

- Position the brake line and wiring harness. Put the clamp on, mount and tighten screw ③.

Finishing work

- Check the headlight setting. (☛ p. 100)

15.8 Changing the headlight bulb

Note

Damage to reflector Reduced brightness.

- Grease on the lamp will evaporate due to the heat and be deposited on the reflector. Clean the lamp and keep it free of grease before mounting.

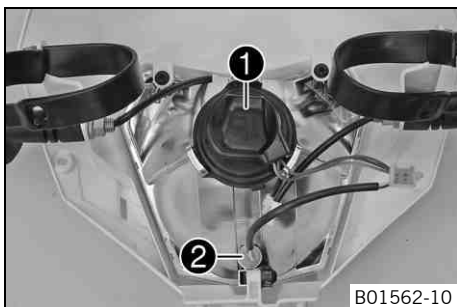

Preparatory work

- Remove the headlight mask with the headlight. (☛ p. 98)

Main work

- Turn protection cap ① together with the underlying bulb socket counterclockwise all the way and remove it.
- Pull bulb socket ② of the parking light out of the reflector.

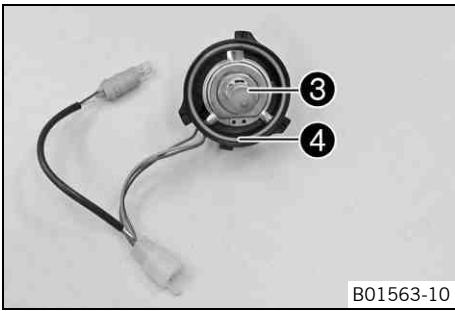

- Pull out headlight bulb ③.
- Insert the new headlight bulb.

Headlight (HS1 / socket PX43t) (☛ p. 122)

- Insert the protection cap with the bulb socket into the reflector and turn it clockwise all the way.



Info

Ensure that O-ring ④ is seated properly.

- Insert the bulb socket of the parking light into the reflector.

Finishing work

- Refit the headlight mask with the headlight. (☛ p. 99)
- Check the headlight setting. (☛ p. 100)

15.9 Checking the headlight setting

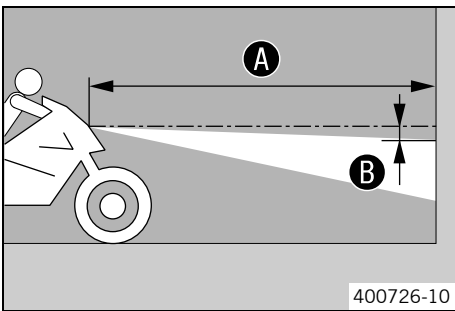

- Position the vehicle upright on a horizontal surface in front of a light wall and make a mark at the height of the center of the low beam headlight.
- Make another mark a distance ② under the first mark.

Guideline

| | |
|------------|-------------|
| Distance ② | 5 cm (2 in) |
|------------|-------------|

- Position the vehicle vertically a distance ① away from the wall.

Guideline

| | |
|------------|-------------|
| Distance ① | 5 m (16 ft) |
|------------|-------------|

- The rider now sits down on the motorcycle.
- Switch on the low beam.
- Check the headlight setting.

The boundary between light and dark must be exactly on the lower mark for a motorcycle with driver.

- » If the light-dark border does not meet specifications:
 - Adjust the headlight range. (☛ p. 100)

15.10 Adjusting the headlight range



Preparatory work

- Check the headlight setting. (☛ p. 100)

Main work

- Loosen screw ①.
- Adjust the headlight range of the headlight by moving it up or down.

Guideline

The boundary between light and dark must be exactly on the lower mark for a motorcycle with driver (instructions on how to apply the mark: Checking the headlight setting).



Info

A change in weight on the vehicle may require a correction of the headlight range.

- Tighten screw ①.

15.11 Changing the turn signal bulb

Note

Damage to reflector Reduced brightness.

- Grease on the lamp will evaporate due to the heat and be deposited on the reflector. Clean the lamp and keep it free of grease before mounting.

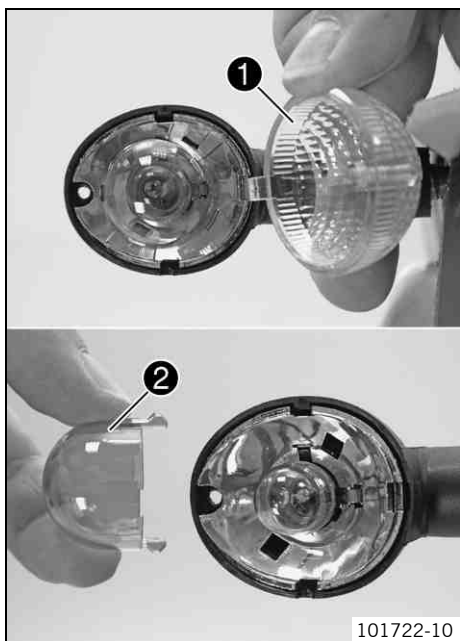

Main work (All EXC-F models)

- Remove the screw on the rear of the turn signal housing.
- Carefully remove diffuser ❶.
- Lightly squeeze orange cap ❷ in the area of the holding lugs and take it off.
- Press the turn signal bulb carefully into the socket, turn it counterclockwise by about 30°, and take it out of the socket.

Info

Do not touch the reflector with your fingers, and keep it free from grease.

- Press the new turn signal bulb carefully into the socket and turn it clockwise until it stops.

Turn signal (R10W / socket BA15s) (☛ p. 122)

- Mount the orange cap.
- Position the diffuser.
- Insert the screw and first turn it counterclockwise until it engages in the thread. Tighten the screw slightly.

Finishing work

- Check that the turn signal system is functioning properly.

15.12 Changing the speedometer battery

Preparatory work

- Remove the headlight mask with the headlight. (☛ p. 98)

Main work (EXC-F EU, EXC-F AUS, XCF-W)

- Remove screws ❶.
- Pull the speedometer upward out of the holder.

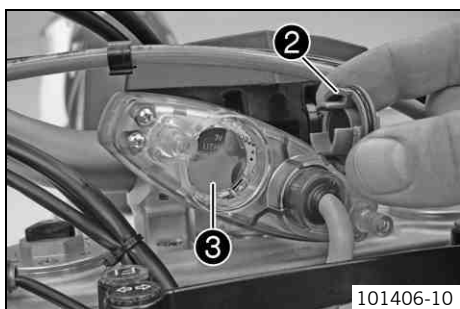
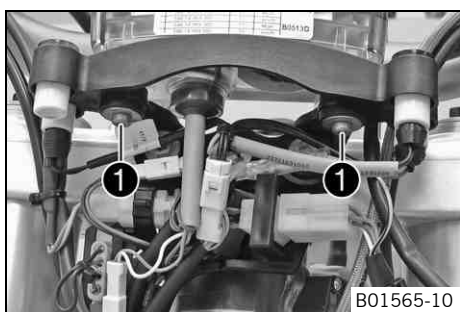

- Using a coin, turn protection cap ❷ all the way counterclockwise and remove it.
- Remove speedometer battery ❸.
- Insert the new battery with the label facing upward.

Speedometer battery (CR 2430) (☛ p. 122)

- Check the O-ring of the protection cap for correct seating.

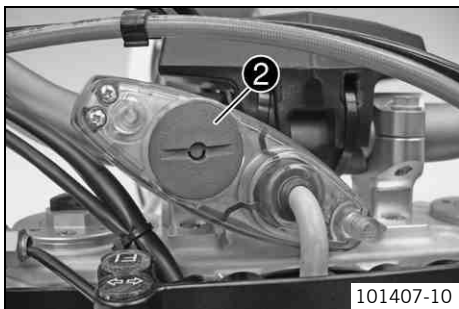

101407-10

- Position protection cap ② and turn all the way clockwise using a coin.
- Press any button on the speedometer.
- ✓ The speedometer is activated.
- Position the speedometer in the holder.
- Mount and tighten the screws with washers.

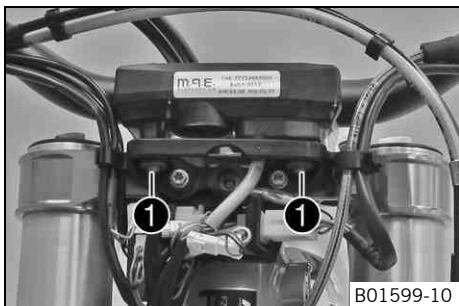

B01599-10

(EXC-F SIX DAYS)

- Remove screws ①.
- Pull the speedometer upward out of the holder.

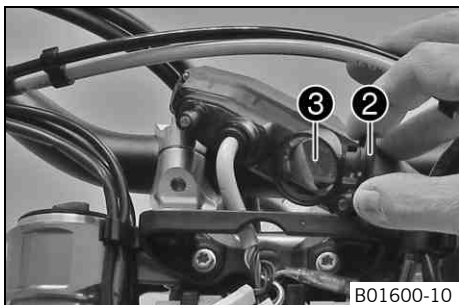

B01600-10

- Using a coin, turn protection cap ② all the way counterclockwise and remove it.
- Remove speedometer battery ③.
- Insert the new battery with the label facing upward.

Speedometer battery (CR 2430) (☛ p. 122)

- Check the O-ring of the protection cap for correct seating.

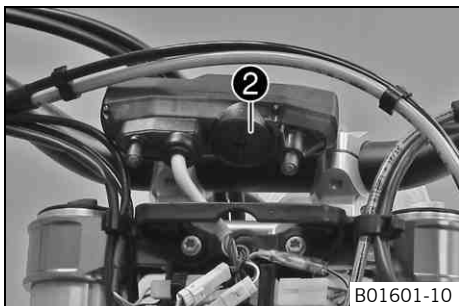

B01601-10

- Position protection cap ② and turn all the way clockwise using a coin.
- Press any button on the speedometer.
- ✓ The speedometer is activated.
- Position the speedometer in the holder.
- Mount and tighten the screws with washers.

Finishing work

- Refit the headlight mask with the headlight. (☛ p. 99)
- Check the headlight setting. (☛ p. 100)
- Set kilometers or miles. (☛ p. 21)
- Adjust the speedometer functions. (☛ p. 22)
- Set the clock. (☛ p. 22)

16.1 Cooling system

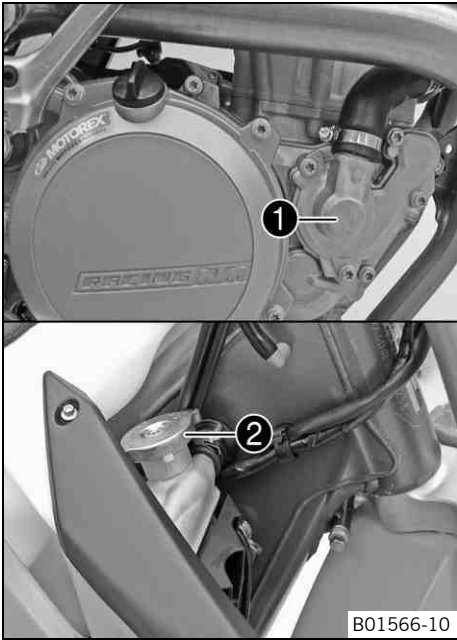

Water pump ❶ in the engine circulates the coolant. The pressure resulting from the warming of the cooling system is regulated by a valve in radiator cap ❷. This ensures that operating the vehicle at the specified coolant temperature will not result in a risk of malfunctions.

| |
|-----------------|
| 120 °C (248 °F) |
|-----------------|

Cooling is effected by the air stream. The lower the speed, the less the cooling effect. Dirty cooling fins also reduce the cooling effect.

(EXC-F SIX DAYS, XCF-W)

The radiator fan provides extra cooling. It is controlled by a thermostwitch.

16.2 Checking the antifreeze and coolant level

- Warning**
Danger of scalding During motorcycle operation, the coolant gets very hot and is under pressure.
 - Do not remove the radiator cap, radiator hoses or other cooling system components when the engine is hot. Allow the engine and cooling system to cool down. In case of scalding, rinse immediately with lukewarm water.
- Warning**
Danger of poisoning Coolant is poisonous and a health hazard.
 - Coolant must not come into contact with the skin, eyes, or clothing. If contact occurs with the eyes, rinse with water immediately and contact a physician. Immediately clean contaminated areas on the skin with soap and water. If coolant is swallowed, contact a physician immediately. Change clothing that is contaminated with coolant. Keep coolant out of reach of children.

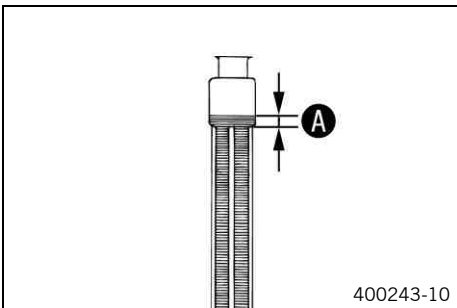

Condition

The engine is cold.

- Stand the motorcycle upright on a horizontal surface.
- Remove the radiator cap.
- Check antifreeze of coolant.

| |
|-------------------------------|
| -25... -45 °C (-13... -49 °F) |
|-------------------------------|

- » If the antifreeze of the coolant does not meet specifications:
 - Correct the antifreeze of the coolant.
- Check the coolant level in the radiator.

| | |
|--------------------------------------|-----------------|
| Coolant level ❶ above radiator fins. | 10 mm (0.39 in) |
|--------------------------------------|-----------------|

- » If the coolant level does not meet specifications:
 - Correct the coolant level.

Alternative 1

| |
|--------------------|
| Coolant (☛ p. 126) |
|--------------------|

Alternative 2

| |
|---|
| Coolant (mixed ready to use) (☛ p. 126) |
|---|

- Mount the radiator cap.

16.3 Checking the coolant level

Warning
Danger of scalding During motorcycle operation, the coolant gets very hot and is under pressure.

- Do not remove the radiator cap, radiator hoses or other cooling system components when the engine is hot. Allow the engine and cooling system to cool down. In case of scalding, rinse immediately with lukewarm water.

Warning
Danger of poisoning Coolant is poisonous and a health hazard.

- Coolant must not come into contact with the skin, eyes, or clothing. If contact occurs with the eyes, rinse with water immediately and contact a physician. Immediately clean contaminated areas on the skin with soap and water. If coolant is swallowed, contact a physician immediately. Change clothing that is contaminated with coolant. Keep coolant out of reach of children.

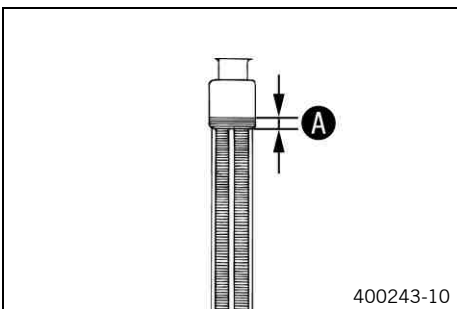

Condition

The engine is cold.

- Stand the motorcycle upright on a horizontal surface.
- Remove the radiator cap.
- Check the coolant level in the radiator.

| | |
|---|-----------------|
| Coolant level A above radiator fins. | 10 mm (0.39 in) |
|---|-----------------|

- » If the coolant level does not meet specifications:
 - Correct the coolant level.

Alternative 1

| |
|--------------------|
| Coolant (☛ p. 126) |
|--------------------|

Alternative 2

| |
|---|
| Coolant (mixed ready to use) (☛ p. 126) |
|---|

- Mount the radiator cap.

16.4 Draining the coolant ☛

Warning
Danger of scalding During motorcycle operation, the coolant gets very hot and is under pressure.

- Do not remove the radiator cap, radiator hoses or other cooling system components when the engine is hot. Allow the engine and cooling system to cool down. In case of scalding, rinse immediately with lukewarm water.

Warning
Danger of poisoning Coolant is poisonous and a health hazard.

- Coolant must not come into contact with the skin, eyes, or clothing. If contact occurs with the eyes, rinse with water immediately and contact a physician. Immediately clean contaminated areas on the skin with soap and water. If coolant is swallowed, contact a physician immediately. Change clothing that is contaminated with coolant. Keep coolant out of reach of children.

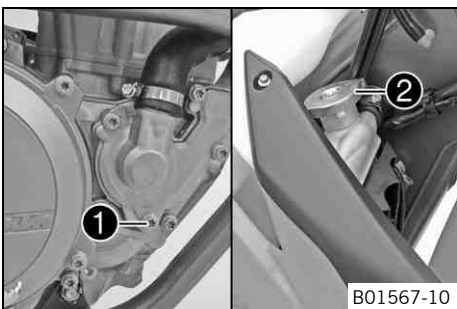

Condition

The engine is cold.

- Position the motorcycle upright.
- Place a suitable container under the water pump cover.
- Remove screw **1**. Take off radiator cap **2**.
- Completely drain the coolant.
- Mount and tighten screw **1** with a new seal ring.

Guideline

| | | |
|-------------------------|----|--------------------|
| Screw, water pump cover | M6 | 10 Nm (7.4 lbf ft) |
|-------------------------|----|--------------------|

16.5 Refilling coolant

Warning
Danger of poisoning Coolant is poisonous and a health hazard.

- Coolant must not come into contact with the skin, eyes, or clothing. If contact occurs with the eyes, rinse with water immediately and contact a physician. Immediately clean contaminated areas on the skin with soap and water. If coolant is swallowed, contact a physician immediately. Change clothing that is contaminated with coolant. Keep coolant out of reach of children.

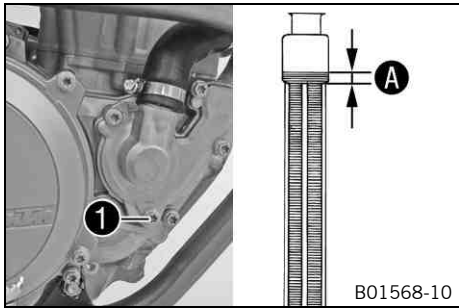



Main work

- Make sure that the screw ❶ is tightened.
- Stand the vehicle upright.
- Pour coolant in up to measurement ❶ above the radiator fins.

Guideline

10 mm (0.39 in)

| | | |
|---------|-----------------|--|
| Coolant | 1.2 l (1.3 qt.) | Coolant ( p. 126) |
| | | Coolant (mixed ready to use) ( p. 126) |

- Refit the radiator cap.

Finishing work

- Take a short test ride.
- Check the coolant level. ( p. 104)

17.1 Checking the play in the throttle cable

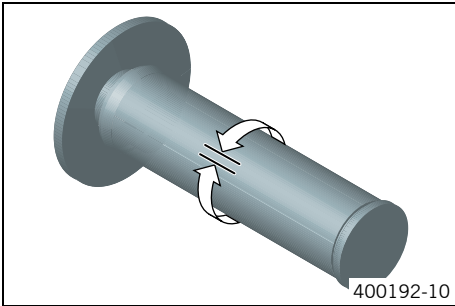

- Check the throttle grip for smooth operation.
- Move the handlebar to the straight-ahead position. Move the throttle grip backwards and forwards to ascertain the play in the throttle cable.

| | |
|------------------------|----------------------------|
| Play in throttle cable | 3... 5 mm (0.12... 0.2 in) |
|------------------------|----------------------------|

- » If the throttle cable play does not meet specifications:
 - Adjust the play in the throttle cable. 🛠️ (👉 p. 106)



Danger

Danger of poisoning Exhaust gases are toxic and inhaling them may result in unconsciousness and/or death.

- When running the engine, always make sure there is sufficient ventilation, and do not start or run the engine in an enclosed space without an effective exhaust extraction system.

- Start the engine and let it run idle. Move the handlebar to and fro over the entire steering range.

| |
|---------------------------------|
| The idle speed must not change. |
|---------------------------------|

- » If the idle speed changes:
 - Adjust the play in the throttle cable. 🛠️ (👉 p. 106)

17.2 Adjusting the play in the throttle cable 🛠️

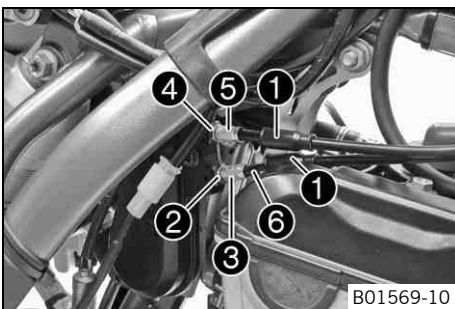

Preparatory work

- Remove the seat. (👉 p. 67)
- Remove the fuel tank. 🛠️ (👉 p. 71)
- Check the throttle cable routing. (👉 p. 77)

Main work

- Move the handlebar to the straight-ahead position.
- Push back sleeves ①.
- Loosen nut ②. Turn adjusting screw ③ in as far as possible.
- Loosen nut ④. Turn adjusting screw ⑤ so that there is play in the throttle cable at the throttle grip.

Guideline

| | |
|------------------------|----------------------------|
| Play in throttle cable | 3... 5 mm (0.12... 0.2 in) |
|------------------------|----------------------------|

- Tighten nut ④.
- Press and hold the throttle grip in the closed setting. Turn adjusting screw ③ out until there is no play in throttle cable ⑥.
- Tighten nut ②.
- Push sleeves ① on. Check the throttle grip for smooth operation.

Finishing work

- Install the fuel tank. 🛠️ (👉 p. 72)
- Mount the seat. (👉 p. 68)
- Check the play in the throttle cable. (👉 p. 106)

17.3 Adjusting the idle speed 🛠️

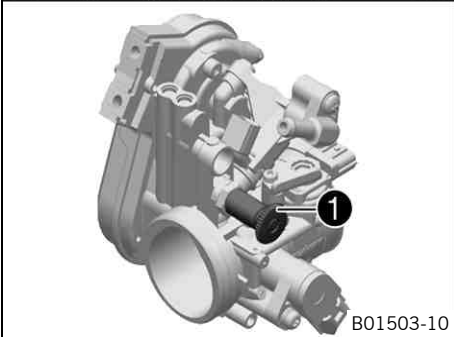
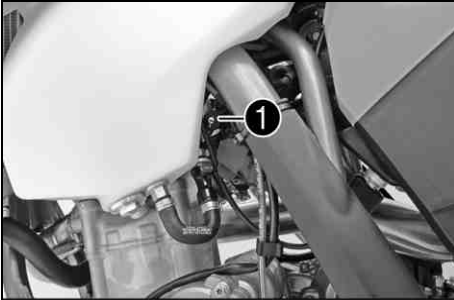

- Run the engine warm and push the idle speed adjusting screw ❶ all the way in.
- Set the desired idle speed by turning the idle speed adjusting screw.

Guideline

| | |
|------------|--------------------|
| Idle speed | 2,050... 2,150 rpm |
|------------|--------------------|

i **Info**

Turn counterclockwise to increase the idle speed.
Turn clockwise to decrease the idle speed.

17.4 Checking the basic position of the shift lever

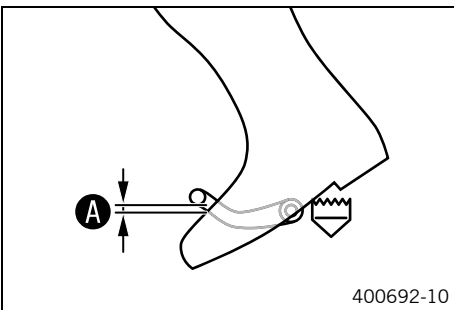

- Sit on the vehicle in the riding position and determine the distance **A** between the upper edge of your boot and the shift lever.

| | |
|---|-------------------------------|
| Gap between the shift lever and the top of the boot | 10... 20 mm (0.39... 0.79 in) |
|---|-------------------------------|

- » If the distance does not meet the specifications:
 - Adjust the basic position of the shift lever. 🛠️ (p. 107)

17.5 Adjusting the basic position of the shift lever 🛠️

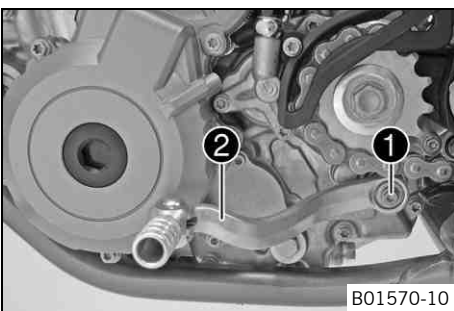

- Remove screw ❶ and take off shift lever ❷.

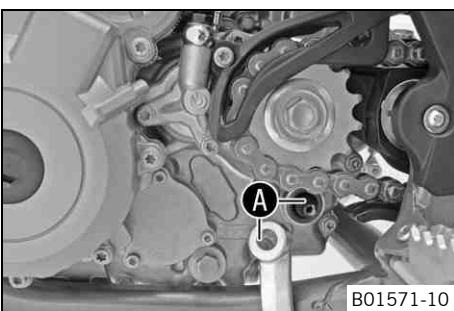

- Clean gear teeth **A** of the shift lever and shift shaft.
- Mount the shift lever on the shift shaft in the required position and engage the gearing.

i **Info**

The range of adjustment is limited.
The shift lever must not come into contact with any other vehicle components during the shift procedure.

- Mount and tighten the screw.

Guideline

| | | | |
|--------------------|----|------------------------|---------------|
| Screw, shift lever | M6 | 14 Nm (10.3 lbf ft) | Loctite® 243™ |
|--------------------|----|------------------------|---------------|

18.1 Changing the fuel screen

 **Danger**
Fire hazard Fuel is highly flammable.

- Never refuel the vehicle near open flames or burning cigarettes, and always switch off the engine first. Be careful that no fuel is spilt, especially on hot vehicle components. Clean up spilt fuel immediately.
- The fuel in the fuel tank expands when warm and may emerge if overfilled. Follow the instructions on refueling.

 **Warning**
Danger of poisoning Fuel is poisonous and a health hazard.

- Fuel must not come into contact with the skin, eyes, or clothing. Do not breathe in the fuel vapors. If contact occurs with the eyes, rinse with water immediately and contact a physician. Immediately clean contaminated areas on the skin with soap and water. If fuel is swallowed, contact a physician immediately. Change clothing that is contaminated with fuel.

 **Warning**
Environmental hazard Improper handling of fuel is a danger to the environment.

- Do not allow fuel to get into the ground water, the ground, or the sewage system.

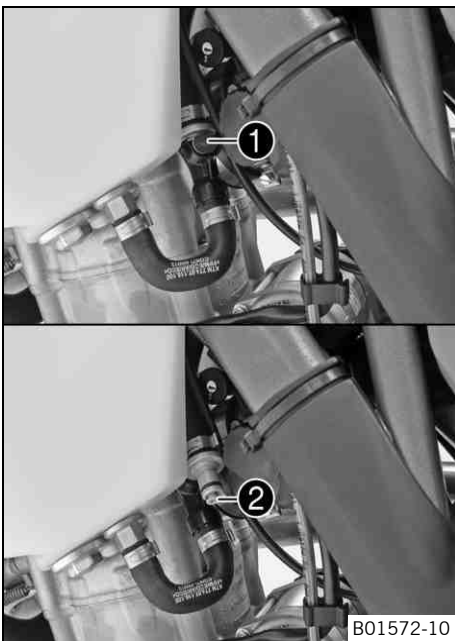

- Clean the plug-in connection **1** of the fuel line thoroughly with compressed air.

 **Info**
 Under no circumstances should dirt enter into the fuel line. Dirt in the fuel line clogs the injection valve.

- Disconnect the plug-in connection **1** of the fuel line.
- Pull fuel screen **2** out of the connecting piece.
- Insert the new fuel screen all the way into the connecting piece.
- Lubricate the O-ring and connect plug-in connection of the fuel line.

 **Danger**
Danger of poisoning Exhaust gases are toxic and inhaling them may result in unconsciousness and/or death.

- When running the engine, always make sure there is sufficient ventilation, and do not start or run the engine in an enclosed space without an effective exhaust extraction system.

- Start the motor and check the response.

18.2 Checking the engine oil level

 **Info**
 The engine oil level can be checked when the engine is cold or warm.

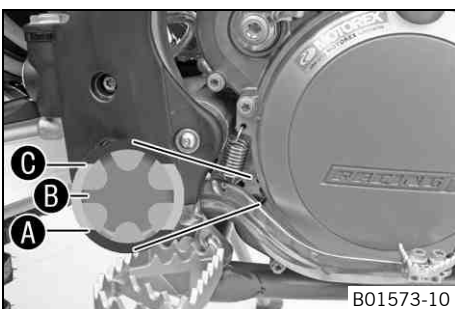

Preparatory work

- Stand the motorcycle upright on a horizontal surface.

Condition

The engine is cold.

- Check the engine oil level.

The engine oil is at a level between the lower edge **A** and the middle **B** of the level viewer.

- » If the engine oil is not up to the lower edge **A** of the level viewer:
 - Add engine oil. (🔧 p. 111)

Condition

The engine is at operating temperature.

- Check the engine oil level.

 **Info**
 After switching off the engine, wait one minute before checking the level.

The engine oil is at a level between the lower edge **A** and the upper edge **B** of the level viewer.

- » If the engine oil is not up to the lower edge **A** of the level viewer:
 - Add engine oil. (☛ p. 111)

18.3 Changing the engine oil and oil filter, cleaning the oil screen ☛

Warning
Danger of scalding Engine oil and gear oil get very hot when the motorcycle is ridden.
 – Wear appropriate protective clothing and safety gloves. In case of burns, rinse immediately with lukewarm water.

Warning
Environmental hazard Hazardous substances cause environmental damage.
 – Oil, grease, filters, fuel, cleaners, brake fluid, etc., should be disposed of as stipulated in applicable regulations.

Info
 Drain the engine oil only when the engine is warm.

Preparatory work
(EXC-F AUS, EXC-F SIX DAYS)

- Remove the engine guard. (☛ p. 80)
- Park the motorcycle on a level surface.

Main work

- Place a suitable container under the engine.
- Remove oil drain plug **1** with the magnet and seal ring.

Info
 Do not remove screws **A** on both sides.

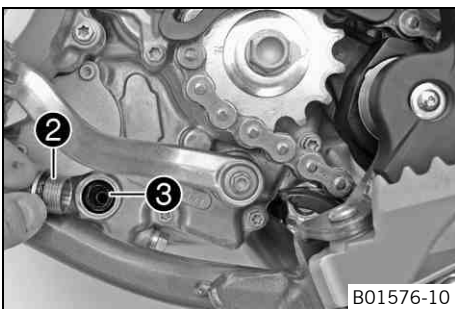
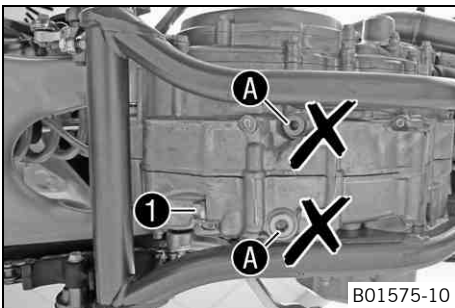

- Remove screw plug **2** with oil screen **3** and the O-rings.
- Completely drain the engine oil.
- Thoroughly clean the parts and sealing surfaces.

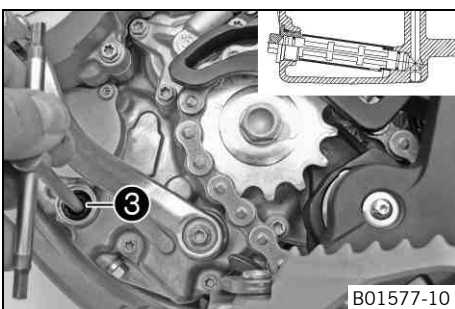

- Push the oil screen with O-rings onto a pin wrench.
- Push the pin wrench through the opening into the drill hole of the opposite engine case wall and push the oil screen as far as possible into the engine case.

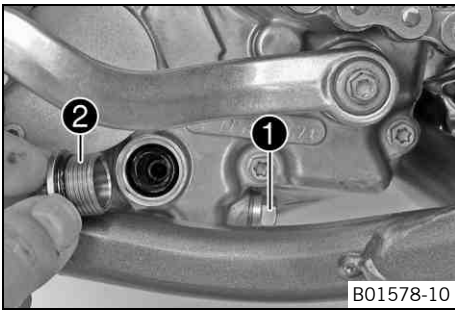

- Mount and tighten screw plug ② with the O-ring.

Guideline

| | | |
|------------------------|---------|------------------------|
| Screw plug, oil screen | M20x1.5 | 15 Nm (11.1 lbf ft) |
|------------------------|---------|------------------------|

- Mount and tighten the oil drain plug ① with the magnet and a new seal ring.

Guideline

| | | |
|----------------------------|---------|------------------------|
| Oil drain plug with magnet | M12x1.5 | 20 Nm (14.8 lbf ft) |
|----------------------------|---------|------------------------|

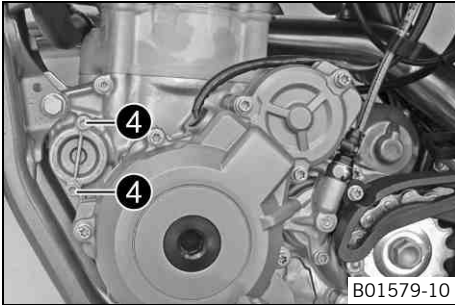

- Remove screws ④. Remove the oil filter cover with the O-ring.

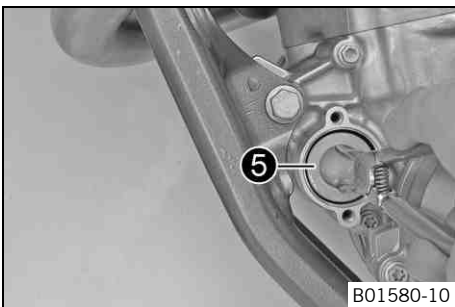

- Pull oil filter ⑤ out of the oil filter housing.

| |
|--------------------------------------|
| Circlip pliers reverse (51012011000) |
|--------------------------------------|

- Completely drain the engine oil.
- Thoroughly clean the parts and sealing surface.

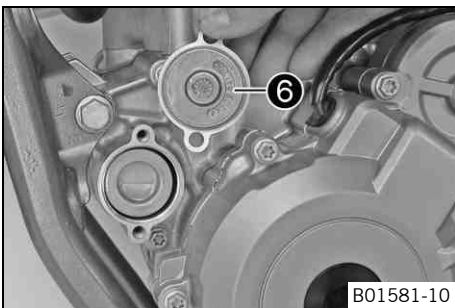

- Lay the motorcycle on its side and fill the oil filter housing to about 1/3 full with engine oil.
- Fill the oil filter with engine oil and place it in the oil filter housing.
- Oil the O-ring of the oil filter cover and mount it with the oil filter cover ⑥.
- Mount and tighten the screws.

Guideline

| | | |
|-------------------------|----|--------------------|
| Screw, oil filter cover | M6 | 10 Nm (7.4 lbf ft) |
|-------------------------|----|--------------------|

- Stand the motorcycle upright.

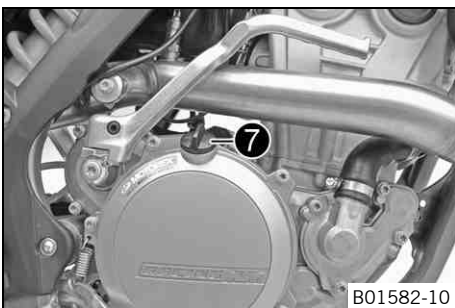

- Remove the oil filler plug ⑦ with the O-ring from the clutch cover and fill up with engine oil.

| | | | |
|------------|-------------------|---|--|
| Engine oil | 1.20 l (1.27 qt.) | Engine oil (SAE 10W/50) (☛ p. 126) | |
| | | Alternative engine oil for harsh operating conditions and increased performance | Engine oil (SAE 10W/60) (00062010035) (☛ p. 126) |

i Info

Too little engine oil or poor-quality engine oil results in premature wear to the engine.

- Install and tighten the oil filler plug with O-ring.

! Danger

Danger of poisoning Exhaust gases are toxic and inhaling them may result in unconsciousness and/or death.

- When running the engine, always make sure there is sufficient ventilation, and do not start or run the engine in an enclosed space without an effective exhaust extraction system.

- Start the engine and check that it is oil-tight.

Finishing work**(EXC-F AUS, EXC-F SIX DAYS)**

- Install the engine guard. (☛ p. 80)
- Check the engine oil level. (☛ p. 108)

18.4 Adding engine oil**Info**

Too little engine oil or poor-quality engine oil results in premature wear to the engine.

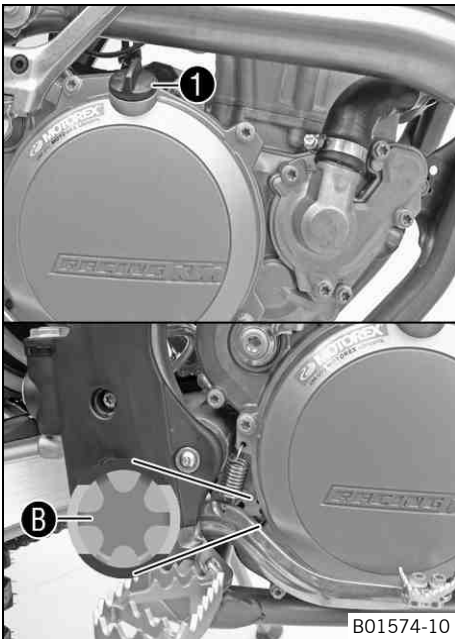
**Main work**

- Remove the oil filler plug 1 with the O-ring from the clutch cover.
- Fill engine oil to the middle B of the level viewer.

Engine oil (SAE 10W/50) (☛ p. 126)

Alternative 1

Engine oil (SAE 10W/60) (00062010035) (☛ p. 126)

**Info**

For optimal performance of the engine oil, do not mix different types of engine oil.
If appropriate, change the engine oil.

- Install and tighten the oil filler plug with O-ring.

**Danger**

Danger of poisoning Exhaust gases are toxic and inhaling them may result in unconsciousness and/or death.

- When running the engine, always make sure there is sufficient ventilation, and do not start or run the engine in an enclosed space without an effective exhaust extraction system.

- Start the engine and check that it is oil-tight.

Finishing work

- Check the engine oil level. (☛ p. 108)

19.1 Cleaning the motorcycle

Note

Material damage Damage and destruction of components by high-pressure cleaning equipment.

- When cleaning the vehicle with a pressure cleaner, do not point the water jet directly onto electrical components, connectors, cables, bearings, etc. Maintain a minimum distance of 60 cm between the nozzle of the pressure cleaner and the component. Excessive pressure can cause malfunctions or destroy these parts.

 **Warning**

Environmental hazard Hazardous substances cause environmental damage.

- Oil, grease, filters, fuel, cleaners, brake fluid, etc., should be disposed of as stipulated in applicable regulations.

 **Info**

If you clean the motorcycle regularly, its value and appearance will be maintained over a long period. Avoid direct sunshine on the motorcycle during cleaning.

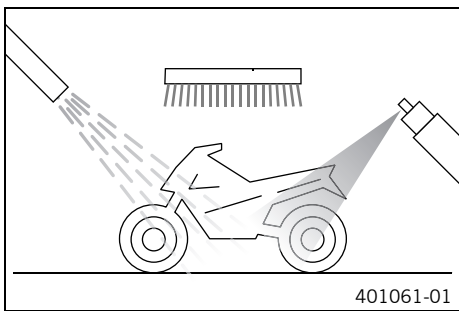

- Close off the exhaust system to prevent water from entering.
- First remove coarse dirt particles with a gentle spray of water.
- Spray very dirty areas with a normal motorcycle cleaner and then clean with a paintbrush.

Motorcycle cleaner (☛ p. 128)

 **Info**

Use warm water containing normal motorcycle cleaner and a soft sponge. Never apply motorcycle cleaner to the dry vehicle; always rinse with water first.

- After rinsing the motorcycle with a gentle spray of water, allow it to dry thoroughly.
- Remove the plug from the exhaust system.



Warning

Danger of accidents Reduced braking efficiency due to a wet or dirty brake system.

- Clean or dry a dirty or wet brake system by riding and braking gently.

- After cleaning, ride a short distance until the engine reaches operating temperature.

 **Info**

The heat produced causes water at inaccessible locations in the engine and brake system to evaporate.

- After the motorcycle has cooled off, lubricate all moving parts and bearings.
- Clean the chain. (☛ p. 74)
- Treat bare metal parts (except for brake discs and exhaust system) with anti-corrosion materials.

Cleaning and preserving materials for metal, rubber and plastic (☛ p. 128)

- Treat all plastic parts and powder-coated parts with a mild cleaning and care product.

Paint cleaner and polish for high-gloss and matte finishes, bare metal and plastic surfaces (☛ p. 129)

19.2 Checks and maintenance steps for winter operation

- i Info**
If the motorcycle is used in the winter, salt can be expected on the roads. Precautions need to be taken against road salt corrosion.
If the vehicle was operated in road salt, clean it with cold water after riding. Warm water would enhance the corrosive effects of salt.

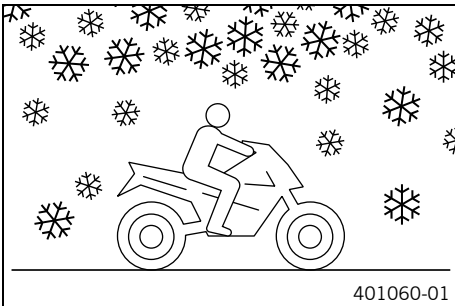

- Clean the motorcycle. (☛ p. 112)
- Clean the brake system.

- i Info**
After **EVERY** trip on salted roads, thoroughly wash the brake calipers and brake linings with cold water and dry carefully. This should be done after the parts are cooled down and while they are installed.
After riding on salted roads, thoroughly wash the motorcycle with cold water and dry it well.

- Treat the engine, swingarm, and all other bright and zinc-plated parts (except for the brake discs) with a wax-based corrosion inhibitor.

- i Info**
Corrosion inhibitor is not permitted to come in contact with the brake discs as this would greatly reduce the braking force.

- Clean the chain. (☛ p. 74)

20.1 Storage



Warning

Danger of poisoning Fuel is poisonous and a health hazard.

- Fuel must not come into contact with the skin, eyes, or clothing. Do not breathe in the fuel vapors. If contact occurs with the eyes, rinse with water immediately and contact a physician. Immediately clean contaminated areas on the skin with soap and water. If fuel is swallowed, contact a physician immediately. Change clothing that is contaminated with fuel. Store fuel properly in a suitable canister and keep away from children.



Info

If you want to garage the motorcycle for a longer period, take the following steps. Before storing the motorcycle, check all parts for function and wear. If service, repairs or replacements are necessary, you should do this during the storage period (less workshop overload). In this way, you can avoid long workshop waiting times at the start of the new season.

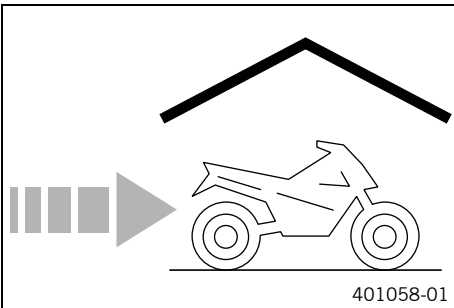

- When refueling for the last time before taking the motorcycle out of service, add fuel additive.

| |
|--------------------------|
| Fuel additive (☞ p. 128) |
|--------------------------|

- Refuel. (☞ p. 45)
- Clean the motorcycle. (☞ p. 112)
- Change the engine oil and oil filter, clean the oil screen. 🛠️ (☞ p. 109)
- Check the antifreeze and coolant level. (☞ p. 103)
- Check the tire air pressure. (☞ p. 93)
- Remove the battery. 🛠️ (☞ p. 95)
- Charge the battery. 🛠️ (☞ p. 96)

Guideline

| | |
|--|--------------------------|
| Storage temperature of battery without direct sunlight | 0... 35 °C (32... 95 °F) |
|--|--------------------------|

- Store the vehicle in a dry location that is not subject to large fluctuations in temperature.



Info

KTM recommends raising the motorcycle.

- Raise the motorcycle with the lift stand. (☞ p. 56)
- Cover the motorcycle with a porous sheet or blanket. Do not use non-porous materials since they prevent humidity from escaping, thus causing corrosion.



Info

Avoid running the engine for a short time only. Since the engine cannot warm up properly, the water vapor produced during combustion condenses and causes valves and exhaust system to rust.



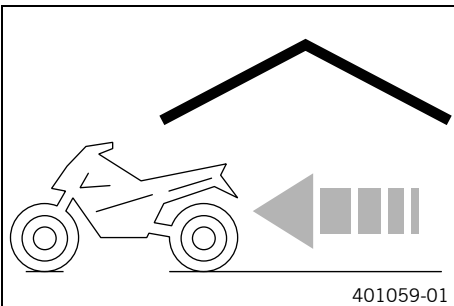







20.2 Preparing for use after storage



- Remove the motorcycle from the lift stand. (☞ p. 56)
- Install the battery. 🛠️ (☞ p. 95)
- Perform checks and maintenance work when preparing the vehicle for use. (☞ p. 42)
- Take a test ride.

| Faults | Possible cause | Action |
|---|---|--|
| The engine cannot be cranked (electric starter) | Operating error | – Carry out the start procedure. (☞ p. 42) |
| | Battery is discharged | – Charge the battery. 🛠️ (☞ p. 96) – Check the charging voltage. 🛠️ – Check the closed current. 🛠️ – Check the stator winding of the alternator. 🛠️ |
| | Main fuse blown | – Change the main fuse. (☞ p. 97) |
| | Starter relay defective | – Check the starter relay. 🛠️ |
| | Starter motor defective | – Check the starter motor. 🛠️ |
| Engine turns but does not start | Operating error | – Carry out the start procedure. (☞ p. 42) |
| | Coupling of fuel hose connection not joined together | – Join the fuel hose connection. |
| | Fuse 1 blown | – Change the fuses of individual power consumers. (☞ p. 98) |
| | Fuse 2 blown | – Change the fuses of individual power consumers. (☞ p. 98) |
| | Idle speed is not set correctly | – Adjust the idle speed. 🛠️ (☞ p. 107) |
| | Spark plug oily or wet | – Clean and dry the spark plug or replace if necessary. |
| | Electrode distance (plug gap) of spark plug too wide | – Adjust the plug gap. Guideline Spark plug electrode gap 1.0 mm (0.039 in) |
| | Ignition system defective | – Check the ignition system. 🛠️ |
| | Short-circuit cable in wiring harness frayed, kill switch or emergency OFF switch defective | – Check the wiring harness. (visual check) – Check the electrical system. |
| Defect in fuel injection system | – Read out the fault memory using the KTM diagnostics tool. 🛠️ | |
| Engine does not speed up | Defect in fuel injection system | – Read out the fault memory using the KTM diagnostics tool. 🛠️ |
| | Ignition system defective | – Ignition coil - check the secondary winding. 🛠️ – Check the spark plug connector. 🛠️ – Check the stator winding of the alternator. 🛠️ |
| Engine has too little power | Air filter heavily contaminated | – Clean the air filter and air filter box. 🛠️ (☞ p. 69) |
| | Fuel filter is very dirty | – Change the fuel filter. 🛠️ |
| | Fuel screen is very dirty | – Change the fuel screen. 🛠️ (☞ p. 108) |
| | Defect in fuel injection system | – Read out the fault memory using the KTM diagnostics tool. 🛠️ |
| | Exhaust system leaky, deformed or too little glass fiber yarn filling in main silencer | – Check exhaust system for damage. – Change the glass fiber yarn filling of the main silencer. 🛠️ (☞ p. 70) |
| | Valve clearance too little | – Adjust the valve clearance. 🛠️ |
| | Ignition system defective | – Ignition coil - check the secondary winding. 🛠️ – Check the spark plug connector. 🛠️ – Check the stator winding of the alternator. 🛠️ |
| Engine dies during the trip | Lack of fuel | – Refuel. (☞ p. 45) |
| | Fuse 1 blown | – Change the fuses of individual power consumers. (☞ p. 98) |
| | Fuse 2 blown | – Change the fuses of individual power consumers. (☞ p. 98) |
| Engine overheats | Coolant level low in cooling system | – Check the cooling system for leaks. – Check the coolant level. (☞ p. 104) |
| | Insufficient airflow | – Switch off engine when stationary. |
| | Radiator fins very dirty | – Clean radiator fins. |

| Faults | Possible cause | Action |
|--|---|--|
| Engine overheats | Foam formation in cooling system | <ul style="list-style-type: none"> – Drain the coolant. 🛠️ (📖 p. 104) – Refill the coolant. 🛠️ (📖 p. 105) |
| | Bent radiator hose | – Change the radiator hose. 🛠️ |
| | Thermostat defective | <ul style="list-style-type: none"> – Check the thermostat. 🛠️ <p>Guideline Opening temperature: 70 °C (158 °F)</p> |
| | Defect in radiator fan system (EXC-F SIX DAYS, XCF-W) | <ul style="list-style-type: none"> – Check the radiator fan fuse. – Check fuse 4. – Check the radiator fan. 🛠️ |
| FI warning lamp (MIL) lights up/flashes | Defect in fuel injection system | <ul style="list-style-type: none"> – Stop the motorcycle and identify the faulty part using the blink code. <hr/> <p>i Info See blink code</p> <hr/> <ul style="list-style-type: none"> – Check the cabling for damage and the electrical plug-in connections for corrosion and damage. – Read out the fault memory using the KTM diagnostics tool. 🛠️ |
| High oil consumption | Engine vent hose bent | – Route the vent hose without bends or replace it if necessary. |
| | Engine oil level too high | – Check the engine oil level. (📖 p. 108) |
| | Engine oil too thin (low viscosity) | – Change the engine oil and oil filter, clean the oil screen. 🛠️ (📖 p. 109) |
| | Piston and cylinder worn | – Measure the piston/cylinder mounting clearance. 🛠️ |
| Battery discharged | Battery is not being charged by alternator | <ul style="list-style-type: none"> – Check the charging voltage. 🛠️ – Check the stator winding of the alternator. 🛠️ |
| | Undesired power consumer | – Check the closed current. 🛠️ |
| Speedometer values deleted (time, stop watch, lap times) | The battery in the speedometer is discharged | – Change the speedometer battery. (📖 p. 101) |
| The high beam, low beam, parking light, tail light, and license plate lamp are not working | Fuse 3 blown | – Change the fuses of individual power consumers. (📖 p. 98) |
| The speedometer, horn, brake light, turn signal, and radiator fan (optional) are not working | Fuse 4 blown | – Change the fuses of individual power consumers. (📖 p. 98) |

| | |
|---|---|
| Blink code FI warning lamp (MIL) |  02 FI warning lamp (MIL) flashes 2x short |
| Error level condition | Crankshaft position sensor - circuit fault |
| Blink code FI warning lamp (MIL) |  06 FI warning lamp (MIL) flashes 6x short |
| Error level condition | Throttle position sensor circuit A - input signal too low Throttle position sensor circuit A - input signal too high |
| Blink code FI warning lamp (MIL) |  09 FI warning lamp (MIL) flashes 9x short |
| Error level condition | Manifold absolute pressure sensor cylinder 1 - input signal too low Manifold absolute pressure sensor cylinder 1 - input signal too high |
| Blink code FI warning lamp (MIL) |  12 FI warning lamp (MIL) flashes 1x long, 2x short |
| Error level condition | Engine coolant temperature sensor - input signal too low Engine coolant temperature sensor - input signal too high |
| Blink code FI warning lamp (MIL) |  13 FI warning lamp (MIL) flashes 1x long, 3x short |
| Error level condition | Intake air temperature sensor - input signal too low Intake air temperature sensor - input signal too high |
| Blink code FI warning lamp (MIL) |  15 FI warning lamp (MIL) flashes 1x long, 5x short |
| Error level condition | Rollover sensor (A/D type) - input signal too low Rollover sensor (A/D type) - input signal too high |
| Blink code FI warning lamp (MIL) |  17 FI warning lamp (MIL) flashes 1x long, 7x short |
| Error level condition | EXC-F EU, EXC-F SIX DAYS Lambda sensor cylinder 1, sensor 1 - circuit fault |
| Blink code FI warning lamp (MIL) |  33 FI warning lamp (MIL) flashes 3x long, 3x short |
| Error level condition | Injector cylinder 1 - circuit fault |
| Blink code FI warning lamp (MIL) |  37 FI warning lamp (MIL) flashes 3x long, 7x short |
| Error level condition | Ignition coil 1, cylinder 1 - circuit fault |
| Blink code FI warning lamp (MIL) |  41 FI warning lamp (MIL) flashes 4x long, 1x short |
| Error level condition | Fuel pump control - open/short circuit to ground Fuel pump control - input signal too low |

| | |
|---|---|
| Blink code FI warning lamp (MIL) |  45 FI warning lamp (MIL) flashes 4x long, 5x short |
| Error level condition | EXC-F EU, EXC-F SIX DAYS Lambda sensor heater cylinder 1, sensor 1 - short circuit to ground or open circuit Lambda sensor heater cylinder 1, sensor 1 - input signal too high |

23.1 Engine

| | |
|---------------------------|---|
| Design | 1-cylinder 4-stroke engine, water-cooled |
| Displacement | 249.91 cm ³ (15.2505 cu in) |
| Stroke | 52.3 mm (2.059 in) |
| Bore | 78 mm (3.07 in) |
| Compression ratio | 12.8:1 |
| Idle speed | 2,050... 2,150 rpm |
| Control | DOHC, four valves controlled via cam lever, drive via timing chain |
| Valve diameter, intake | 32.5 mm (1.28 in) |
| Valve diameter, exhaust | 26.5 mm (1.043 in) |
| Valve clearance | |
| Intake at: 20 °C (68 °F) | 0.10... 0.15 mm (0.0039... 0.0059 in) |
| Exhaust at: 20 °C (68 °F) | 0.13... 0.18 mm (0.0051... 0.0071 in) |
| Crankshaft bearing | 2 cylinder bearings |
| Conrod bearing | Slide bearing |
| Piston pin bearing | Bearing bush |
| Pistons | Forged light alloy |
| Piston rings | 1 compression ring, 1 oil scraper ring |
| Engine lubrication | Pressure circulation lubrication with two Eaton pumps |
| Primary transmission | 24:73 |
| Clutch | Multidisc clutch in oil bath/hydraulically activated |
| Transmission ratio | |
| 1st gear | 13:32 |
| 2nd gear | 16:30 |
| 3rd gear | 16:24 |
| 4th gear | 23:28 |
| 5th gear | 23:23 |
| 6th gear | 26:22 |
| Alternator | 12 V, 168 W |
| Ignition | Contactless controlled fully electronic ignition with digital ignition adjustment |
| Spark plug | NGK LMAR9AI-10 |
| Spark plug electrode gap | 1.0 mm (0.039 in) |
| Cooling | Water cooling, permanent circulation of coolant by water pump |
| Starting aid | Electric starter/kick starter |

23.2 Engine tightening torques

| | | | |
|--|----|-------------------|---------------|
| Nozzle, crank chamber ventilation | M4 | 2 Nm (1.5 lbf ft) | Loctite® 243™ |
| Oil nozzle for alternator cooling | M4 | 2 Nm (1.5 lbf ft) | Loctite® 243™ |
| Oil nozzle for balancer shaft lubrication | M4 | 2 Nm (1.5 lbf ft) | Loctite® 243™ |
| Oil nozzle for conrod bearing lubrication | M4 | 2 Nm (1.5 lbf ft) | Loctite® 243™ |
| Screw, oil nozzle for piston cooling | M4 | 2 Nm (1.5 lbf ft) | Loctite® 243™ |
| Locking screw for bearing | M5 | 6 Nm (4.4 lbf ft) | Loctite® 243™ |
| Oil nozzle for cam lever lubrication | M5 | 3 Nm (2.2 lbf ft) | Loctite® 243™ |
| Oil nozzle for clutch lubrication | M5 | 6 Nm (4.4 lbf ft) | Loctite® 243™ |
| Oil nozzle, piston cooling | M5 | 2 Nm (1.5 lbf ft) | Loctite® 243™ |
| Screw cap, oil channel in alternator cover | M5 | 3 Nm (2.2 lbf ft) | Loctite® 243™ |
| Screw, clutch spring | M5 | 6 Nm (4.4 lbf ft) | – |
| Screw, crankshaft position sensor | M5 | 6 Nm (4.4 lbf ft) | Loctite® 243™ |

| | | | |
|--|-----------|---|--|
| Screw, locking lever | M5 | 6 Nm (4.4 lbf ft) | Loctite® 243™ |
| Screw, oil pump cover | M5 | 6 Nm (4.4 lbf ft) | Loctite® 243™ |
| Screw, stator | M5 | 6 Nm (4.4 lbf ft) | Loctite® 648™ |
| Nut, cylinder head | M6 | 10 Nm (7.4 lbf ft) | Lubricated with engine oil |
| Nut, water-pump wheel | M6 | 6 Nm (4.4 lbf ft) | Loctite® 243™ |
| Screw, alternator cover | M6 | 10 Nm (7.4 lbf ft) | – |
| Screw, clutch cover | M6 | 10 Nm (7.4 lbf ft) | – |
| Screw, clutch slave cylinder | M6 | 10 Nm (7.4 lbf ft) | – |
| Screw, engine case | M6 | 10 Nm (7.4 lbf ft) | – |
| Screw, exhaust flange | M6 | 10 Nm (7.4 lbf ft) | Loctite® 243™ |
| Screw, kick starter stop | M6 | 10 Nm (7.4 lbf ft) | Loctite® 243™ |
| Screw, oil filter cover | M6 | 10 Nm (7.4 lbf ft) | – |
| Screw, shift drum locating | M6 | 10 Nm (7.4 lbf ft) | Loctite® 243™ |
| Screw, shift lever | M6 | 14 Nm (10.3 lbf ft) | Loctite® 243™ |
| Screw, starter motor | M6 | 10 Nm (7.4 lbf ft) | – |
| Screw, timing chain securing guide | M6 | 10 Nm (7.4 lbf ft) | Loctite® 243™ |
| Screw, valve cover | M6 | 8 Nm (5.9 lbf ft) | – |
| Screw, water pump cover | M6 | 10 Nm (7.4 lbf ft) | – |
| Stud, cylinder head | M6 | 10 Nm (7.4 lbf ft) | – |
| Screw, camshaft bearing bridge | M7x1 | 14 Nm (10.3 lbf ft) | Lubricated with engine oil |
| Screw plug, crankshaft location | M8 | 10 Nm (7.4 lbf ft) | – |
| Screw, kick starter | M8 | 25 Nm (18.4 lbf ft) | Loctite® 243™ |
| Screw, timing chain tensioning rail | M8 | 15 Nm (11.1 lbf ft) | Loctite® 243™ |
| Screw, engine sprocket | M10 | 60 Nm (44.3 lbf ft) | Loctite® 2701™ |
| Plug, oil channel | M10x1 | 15 Nm (11.1 lbf ft) | Loctite® 243™ |
| Rotor screw | M10x1 | 70 Nm (51.6 lbf ft) | Thread, oiled with engine oil/cone degreased |
| Screw plug, cam lever axis | M10x1 | 10 Nm (7.4 lbf ft) | – |
| Screw, unlocking of timing chain tensioner | M10x1 | 10 Nm (7.4 lbf ft) | – |
| Spark plug | M10x1 | 10... 12 Nm (7.4... 8.9 lbf ft) | – |
| Nut, cylinder head | M10x1.25 | Tightening sequence: Tighten diagonally. 1st tightening stage 10 Nm (7.4 lbf ft) 2nd tightening stage 30 Nm (22.1 lbf ft) 3rd tightening stage 50° | Thread, oiled with engine oil/cone greased |
| Stud, cylinder head | M10x1.25 | 20 Nm (14.8 lbf ft) | Loctite® 243™ |
| Engine coolant temperature sensor | M12x1.5 | 12 Nm (8.9 lbf ft) | – |
| Oil drain plug with magnet | M12x1.5 | 20 Nm (14.8 lbf ft) | – |
| Plug, oil pressure regulator valve | M12x1.5 | 20 Nm (14.8 lbf ft) | – |
| Oil drain plug | M14x1.5 | 15 Nm (11.1 lbf ft) | – |
| Nut, inner clutch hub | M18x1.5 | 100 Nm (73.8 lbf ft) | Loctite® 243™ |
| Nut, primary gear | M18LHx1.5 | 100 Nm (73.8 lbf ft) | Loctite® 243™ |
| Screw plug, oil screen | M20x1.5 | 15 Nm (11.1 lbf ft) | – |
| Plug, timing chain tensioner | M24x1.5 | 25 Nm (18.4 lbf ft) | – |
| Screw, alternator cover | M24x1.5 | 18 Nm (13.3 lbf ft) | – |

23.3 Capacities

23.3.1 Engine oil

| | | |
|------------|-------------------|---|
| Engine oil | 1.20 l (1.27 qt.) | Engine oil (SAE 10W/50) (☛ p. 126) |
| | | Alternative engine oil for harsh operating conditions and increased performance |
| | | Engine oil (SAE 10W/60) (00062010035) (☛ p. 126) |

23.3.2 Coolant

| | | |
|---------|-----------------|---|
| Coolant | 1.2 l (1.3 qt.) | Coolant (☛ p. 126) |
| | | Coolant (mixed ready to use) (☛ p. 126) |

23.3.3 Fuel

| | | |
|--|---------------------|--|
| Total fuel tank capacity, approx. (All EXC-F models) | 9 l (2.4 US gal) | Super unleaded (ROZ 95/RON 95/PON 91) (☛ p. 127) |
| Total fuel tank capacity, approx. (XCF-W) | 8.5 l (2.25 US gal) | Super unleaded (ROZ 95/RON 95/PON 91) (☛ p. 127) |
| Fuel reserve, approx. | 1.5 l (1.6 qt.) | |

23.4 Chassis

| | | |
|--|---|--|
| Frame | Central tube frame made of chrome molybdenum steel tubing | |
| Fork (EXC-F EU, EXC-F AUS, XCF-W) | WP Suspension Up Side Down 4860 MXMA PA | |
| Fork (EXC-F SIX DAYS) | WP Suspension Up Side Down 4860 4CS | |
| Suspension travel (EXC-F EU, EXC-F AUS, XCF-W) | | |
| Front | 300 mm (11.81 in) | |
| Suspension travel (EXC-F SIX DAYS) | | |
| Front | 292 mm (11.5 in) | |
| Suspension travel | | |
| Rear | 335 mm (13.19 in) | |
| Fork offset | 20 mm (0.79 in) | |
| Shock absorber | WP Suspension PDS 5018 DCC | |
| Brake system | Disc brakes, brake calipers on floating bearings | |
| Brake discs - diameter | | |
| Front | 260 mm (10.24 in) | |
| Rear | 220 mm (8.66 in) | |
| Brake discs - wear limit | | |
| Front | 2.5 mm (0.098 in) | |
| Rear | 3.5 mm (0.138 in) | |
| Tire air pressure off road | | |
| Front | 1.0 bar (15 psi) | |
| Rear | 1.0 bar (15 psi) | |
| Road tire pressure (All EXC-F models) | | |
| Front | 1.5 bar (22 psi) | |
| Rear | 1.5 bar (22 psi) | |
| Final drive (All EXC-F models) | 14:52 (13:52) | |
| Final drive (XCF-W) | 13:52 | |
| Chain | 5/8 x 1/4" | |
| Rear sprockets available | 38, 40, 42, 45, 48, 49, 50, 51, 52 | |
| Steering head angle | 63.5° | |
| Wheelbase | 1,482±10 mm (58.35±0.39 in) | |
| Seat height unloaded | 970 mm (38.19 in) | |
| Ground clearance unloaded | 345 mm (13.58 in) | |

| | |
|---|----------------------|
| Homologated weight without fuel, approx. (All EXC-F models) | 109.5 kg (241.4 lb.) |
| Homologated weight without fuel, approx. (EXC-F SIX DAYS) | 112.0 kg (246.9 lb.) |
| Weight without fuel, approx. (XCF-W) | 105.5 kg (232.6 lb.) |
| Maximum permissible front axle load | 145 kg (320 lb.) |
| Maximum permissible rear axle load | 190 kg (419 lb.) |
| Maximum permissible overall weight | 335 kg (739 lb.) |

23.5 Electrical system

| | | |
|---------------------------------------|------------------------|---|
| Battery | YTX4L-BS | Battery voltage: 12 V Nominal capacity: 3 Ah Maintenance-free |
| Speedometer battery | CR 2430 | Battery voltage: 3 V |
| Fuse | 58011109105 | 5 A |
| Fuse | 75011088010 | 10 A |
| Fuse | 58011109120 | 20 A |
| Headlight | HS1 / socket PX43t | 12 V 35/35 W |
| Parking light | W5W / socket W2.1x9.5d | 12 V 5 W |
| Indicator lamps | W2.3W / socket W2x4.6d | 12 V 2.3 W |
| Turn signal (All EXC-F models) | R10W / socket BA15s | 12 V 10 W |
| Brake/tail light | LED | |
| License plate lamp (All EXC-F models) | W5W / socket W2.1x9.5d | 12 V 5 W |

23.6 Tires

| Validity | Front tires | Rear tires |
|--------------------|---|---|
| (All EXC-F models) | 80/100 - 21 M/C 51M TT MAXXIS MAXX CROSS SI | 140/80 - 18 M/C 70R TT MAXXIS MAXX ENDURO |
| (XCF-W) | 80/100 - 21 51M TT Dunlop GEOMAX MX51FA | 110/100 - 18 64M TT Dunlop GEOMAX MX51 |

Additional information is available in the Service section under:
<http://www.ktm.com>

23.7 Fork

23.7.1 EXC-F EU, EXC-F AUS, XCF-W

| | |
|--|--|
| Fork part number | 14.18.7L.67 |
| Fork | WP Suspension Up Side Down 4860 MXMA PA |
| Compression damping | |
| Comfort | 22 clicks |
| Standard | 20 clicks |
| Sport | 18 clicks |
| Rebound damping | |
| Comfort | 20 clicks |
| Standard | 18 clicks |
| Sport | 16 clicks |
| Spring preload - Preload Adjuster | |
| Comfort | 1 turn |
| Standard | 2 turns |
| Sport | 2 turns |
| Spring length with preload spacer(s) | |

| | |
|---|--|
| Weight of rider: 65... 75 kg (143... 165 lb.) | 513 mm (20.2 in) |
| Weight of rider: 75... 85 kg (165... 187 lb.) | 513 mm (20.2 in) |
| Weight of rider: 85... 95 kg (187... 209 lb.) | 513 mm (20.2 in) |
| Spring rate | |
| Weight of rider: 65... 75 kg (143... 165 lb.) | 4.0 N/mm (22.8 lb/in) |
| Weight of rider: 75... 85 kg (165... 187 lb.) | 4.2 N/mm (24 lb/in) |
| Weight of rider: 85... 95 kg (187... 209 lb.) | 4.4 N/mm (25.1 lb/in) |
| Fork length | 940 mm (37.01 in) |
| Air chamber length | 110 ⁺¹⁰ ₋₂₀ mm (4.33 ^{+0.39} _{-0.79} in) |

| | | |
|-----------------------|------------------------|--|
| Fork oil per fork leg | 620 ml (20.96 fl. oz.) | Fork oil (SAE 4) (48601166S1) (☛ p. 127) |
|-----------------------|------------------------|--|

23.7.2 EXC-F SIX DAYS

| | |
|---|--|
| Fork part number | 24.18.7N.67 |
| Fork | WP Suspension Up Side Down 4860 4CS |
| Compression damping | |
| Comfort | 15 clicks |
| Standard | 13 clicks |
| Sport | 11 clicks |
| Rebound damping | |
| Comfort | 15 clicks |
| Standard | 13 clicks |
| Sport | 11 clicks |
| Spring length with preload spacer(s) | 472 mm (18.58 in) |
| Spring rate | |
| Weight of rider: 65... 75 kg (143... 165 lb.) | 4.0 N/mm (22.8 lb/in) |
| Weight of rider: 75... 85 kg (165... 187 lb.) | 4.2 N/mm (24 lb/in) |
| Weight of rider: 85... 95 kg (187... 209 lb.) | 4.4 N/mm (25.1 lb/in) |
| Fork length | 932 mm (36.69 in) |
| Air chamber length | 100 mm (3.94 in) |

| | | |
|-----------------------|------------------------|--|
| Fork oil per fork leg | 635 ml (21.47 fl. oz.) | Fork oil (SAE 4) (48601166S1) (☛ p. 127) |
|-----------------------|------------------------|--|

23.8 Shock absorber

| | |
|---|-----------------------------------|
| Shock absorber part number | 12.18.7L.67 |
| Shock absorber | WP Suspension PDS 5018 DCC |
| Compression damping, low-speed | |
| Comfort | 25 clicks |
| Standard | 20 clicks |
| Sport | 15 clicks |
| Compression damping, high-speed | |
| Comfort | 2 turns |
| Standard | 1.5 turns |
| Sport | 1.25 turns |
| Rebound damping | |
| Comfort | 28 clicks |
| Standard | 24 clicks |
| Sport | 22 clicks |
| Spring preload | 8 mm (0.31 in) |
| Spring rate | |
| Weight of rider: 65... 75 kg (143... 165 lb.) | 66 N/mm (377 lb/in) |
| Weight of rider: 75... 85 kg (165... 187 lb.) | 69 N/mm (394 lb/in) |
| Weight of rider: 85... 95 kg (187... 209 lb.) | 72 N/mm (411 lb/in) |

| | |
|---------------|--|
| Spring length | 250 mm (9.84 in) |
| Gas pressure | 10 bar (145 psi) |
| Static sag | 33... 35 mm (1.3... 1.38 in) |
| Riding sag | 105... 115 mm (4.13... 4.53 in) |
| Fitted length | 417 mm (16.42 in) |
| Damper oil | Shock absorber oil (SAE 2.5) (50180342S1) (☛ p. 127) |

23.9 Chassis tightening torques

| | | | |
|---|-----------------|-------------------------------|-----------------------|
| Screw, pressure regulator | EJOT PT® | 3 Nm (2.2 lbf ft) | – |
| Spoke nipple, front wheel | M4.5 | 5... 6 Nm (3.7... 4.4 lbf ft) | – |
| Spoke nipple, rear wheel | M4.5 | 5... 6 Nm (3.7... 4.4 lbf ft) | – |
| Screw, battery terminal | M5 | 2.5 Nm (1.84 lbf ft) | – |
| Screw, intake air temperature sensor | M5 | 2 Nm (1.5 lbf ft) | – |
| Screw, shock absorber adjusting ring | M5 | 5 Nm (3.7 lbf ft) | – |
| Screw, spoiler on fuel tank (XCF-W) | M5x12 | 1.5 Nm (1.11 lbf ft) | – |
| Nut, cable on starter motor | M6 | 4 Nm (3 lbf ft) | – |
| Remaining nuts, chassis | M6 | 10 Nm (7.4 lbf ft) | – |
| Remaining screws, chassis | M6 | 10 Nm (7.4 lbf ft) | – |
| Screw, ball joint of push rod on foot brake cylinder | M6 | 10 Nm (7.4 lbf ft) | Loctite® 243™ |
| Screw, chain sliding guard | M6 | 6 Nm (4.4 lbf ft) | Loctite® 243™ |
| Screw, front brake disc | M6 | 14 Nm (10.3 lbf ft) | Loctite® 243™ |
| Screw, rear brake disc | M6 | 14 Nm (10.3 lbf ft) | Loctite® 243™ |
| Screw, throttle grip | M6 | 5 Nm (3.7 lbf ft) | – |
| Fuel connection on fuel pump | M8 | 10 Nm (7.4 lbf ft) | – |
| Nut, foot brake lever stop | M8 | 20 Nm (14.8 lbf ft) | – |
| Nut, rear sprocket screw | M8 | 35 Nm (25.8 lbf ft) | Loctite® 2701™ |
| Nut, rim lock | M8 | 12 Nm (8.9 lbf ft) | – |
| Remaining nuts, chassis | M8 | 25 Nm (18.4 lbf ft) | – |
| Remaining screws, chassis | M8 | 25 Nm (18.4 lbf ft) | – |
| Screw, bottom triple clamp (EXC-F SIX DAYS) | M8 | 15 Nm (11.1 lbf ft) | – |
| Screw, bottom triple clamp (EXC-F EU, EXC-F AUS, XCF-W) | M8 | 15 Nm (11.1 lbf ft) | – |
| Screw, chain sliding piece | M8 | 15 Nm (11.1 lbf ft) | – |
| Screw, engine brace | M8 | 33 Nm (24.3 lbf ft) | – |
| Screw, fork stub | M8 | 15 Nm (11.1 lbf ft) | – |
| Screw, front brake caliper | M8 | 25 Nm (18.4 lbf ft) | Loctite® 243™ |
| Screw, handlebar clamp | M8 | 20 Nm (14.8 lbf ft) | – |
| Screw, side stand attachment | M8 | 45 Nm (33.2 lbf ft) | Loctite® 2701™ |
| Screw, subframe | M8 | 35 Nm (25.8 lbf ft) | Loctite® 2701™ |
| Screw, top steering stem (EXC-F SIX DAYS) | M8 | 17 Nm (12.5 lbf ft) | Loctite® 243™ |
| Screw, top steering stem (EXC-F EU, EXC-F AUS, XCF-W) | M8 | 20 Nm (14.8 lbf ft) | – |
| Screw, top triple clamp (EXC-F SIX DAYS) | M8 | 17 Nm (12.5 lbf ft) | – |
| Screw, top triple clamp (EXC-F EU, EXC-F AUS, XCF-W) | M8 | 20 Nm (14.8 lbf ft) | – |
| Engine attachment bolt | M10 | 60 Nm (44.3 lbf ft) | – |
| Remaining nuts, chassis | M10 | 45 Nm (33.2 lbf ft) | – |
| Remaining screws, chassis | M10 | 45 Nm (33.2 lbf ft) | – |
| Screw, handlebar holder | M10 | 40 Nm (29.5 lbf ft) | Loctite® 243™ |

| | | | |
|----------------------------------|---------|----------------------|-----------------------|
| Nut, fuel pump fixation | M12 | 15 Nm (11.1 lbf ft) | – |
| Screw, bottom shock absorber | M12 | 80 Nm (59 lbf ft) | Loctite® 2701™ |
| Screw, top shock absorber | M12 | 80 Nm (59 lbf ft) | Loctite® 2701™ |
| Nut, seat fixing | M12x1 | 20 Nm (14.8 lbf ft) | – |
| Nut, swingarm pivot | M16x1.5 | 100 Nm (73.8 lbf ft) | – |
| Nut, rear wheel spindle | M20x1.5 | 80 Nm (59 lbf ft) | – |
| Screw, top steering head | M20x1.5 | 12 Nm (8.9 lbf ft) | – |
| Screw-in nozzles, cooling system | M20x1.5 | 12 Nm (8.9 lbf ft) | Loctite® 243™ |
| Screw, front wheel spindle | M24x1.5 | 45 Nm (33.2 lbf ft) | – |

Brake fluid DOT 4 / DOT 5.1

According to

- DOT

Guideline

- Use only brake fluid that complies with the specified standard (see specifications on the container) and that possesses the corresponding properties. KTM recommends **Castrol** and **Motorex®** products.

Supplier

Castrol

- **RESPONSE BRAKE FLUID SUPER DOT 4**

Motorex®

- **Brake Fluid DOT 5.1**

Coolant

Guideline

- Use only suitable coolant (also in countries with high temperatures). Use of low-quality antifreeze can lead to corrosion and foaming. KTM recommends **Motorex®** products.

Mixture ratio

| | |
|--|---|
| Antifreeze protection: -25... -45 °C (-13... -49 °F) | 50 % corrosion inhibitor/antifreeze 50 % distilled water |
|--|---|

Coolant (mixed ready to use)

| | |
|------------|-----------------|
| Antifreeze | -40 °C (-40 °F) |
|------------|-----------------|

Supplier

Motorex®

- **COOLANT G48**

Engine oil (SAE 10W/60) (00062010035)

According to

- JASO T903 MA (☛ p. 130)
- SAE (☛ p. 130) (SAE 10W/60)
- KTM LC4 2007+

Guideline

- Use only engine oils that comply with the specified standards (see specifications on the container) and that possess the corresponding properties. KTM recommends **Motorex®** products.

| |
|----------------------|
| Synthetic engine oil |
|----------------------|

Supplier

Motorex®

- **Cross Power 4T**

Engine oil (SAE 10W/50)

According to

- JASO T903 MA (☛ p. 130)
- SAE (☛ p. 130) (SAE 10W/50)

Guideline

- Use only engine oils that comply with the specified standards (see specifications on the container) and that possess the corresponding properties. KTM recommends **Motorex®** products.

| |
|----------------------|
| Synthetic engine oil |
|----------------------|

Supplier

Motorex®

- **Cross Power 4T**

Fork oil (SAE 4) (48601166S1)

According to

- SAE (☛ p. 130) (SAE 4)

Guideline

- Use only oils that comply with the specified standards (see specifications on the container) and that possess the corresponding properties.

Shock absorber oil (SAE 2.5) (50180342S1)

According to

- SAE (☛ p. 130) (SAE 2.5)

Guideline

- Use only oils that comply with the specified standards (see specifications on the container) and that possess the corresponding properties.

Super unleaded (ROZ 95/RON 95/PON 91)

According to

- DIN EN 228 (ROZ 95/RON 95/PON 91)

Guideline

- Only use unleaded super fuel that matches or is equivalent to the specified fuel grade.
- Fuel with an ethanol content of up to 10 % (E10 fuel) is safe to use.



Info

Do **not** use fuel containing methanol (e. g. M15, M85, M100) or more than 10 % ethanol (e. g. E15, E25, E85, E100).

Air filter cleaner

Guideline

- KTM recommends **Motorex®** products.

Supplier

Motorex®

- **Twin Air Dirt Bio Remover**

Chain cleaner

Guideline

- KTM recommends **Motorex®** products.

Supplier

Motorex®

- **Chain Clean**

Cleaning and preserving materials for metal, rubber and plastic

Guideline

- KTM recommends **Motorex®** products.

Supplier

Motorex®

- **Protect & Shine**

Fuel additive

Guideline

- KTM recommends **Motorex®** products.

Supplier

Motorex®

- **Fuel Stabilizer**

High viscosity grease

Guideline

- KTM recommends **SKF®** products.

Supplier

SKF®

- **LGHB 2**

Long-life grease

Guideline

- KTM recommends **Motorex®** products.

Supplier

Motorex®

- **Bike Grease 2000**

Motorcycle cleaner

Guideline

- KTM recommends **Motorex®** products.

Supplier

Motorex®

- **Moto Clean 900**

Off-road chain spray

Guideline

- KTM recommends **Motorex®** products.

Supplier

Motorex®

- **Chainlube Offroad**

Oil for foam air filter

Guideline

- KTM recommends **Motorex®** products.

Supplier

Motorex®

- **Twin Air Liquid Bio Power**

Paint cleaner and polish for high-gloss and matte finishes, bare metal and plastic surfaces

Guideline

- KTM recommends **Motorex®** products.

Supplier

Motorex®

- **Clean & Polish**

Rubber grip adhesive (00062030051)

Supplier

KTM-Sportmotorcycle AG

- **GRIP GLUE**

Universal oil spray

Guideline

- KTM recommends **Motorex®** products.

Supplier

Motorex®

- **Joker 440 Synthetic**

JASO T903 MA

Different technical development directions required a new specification for 4-stroke motorcycles – the JASO T903 MA Standard. Earlier, engine oils from the automobile industry were used for 4-stroke motorcycles because there was no separate motorcycle specification. Whereas long service intervals are demanded for automobile engines, high performance at high engine speeds are in the foreground for motorcycle engines. In most motorcycles, the gearbox and the clutch are lubricated with the same oil as the engine. The JASO MA Standard meets these special requirements.

SAE

The SAE viscosity classes were defined by the Society of Automotive Engineers and are used for classifying oils according to their viscosity. The viscosity describes only one property of oil and says nothing about quality.

| | |
|-------------------------------------|----------|
| A | |
| Accessories | 9 |
| Air filter | |
| cleaning | 69 |
| installing | 69 |
| removing | 68 |
| Air filter box | |
| cleaning | 69 |
| sealing | 70 |
| Air filter box lid | |
| installing | 68 |
| removing | 68 |
| Antifreeze | |
| checking | 103 |
| Auxiliary substances | 9 |
| B | |
| Basic suspension setting | |
| checking against the rider's weight | 48 |
| Battery | |
| charging | 96 |
| installing | 95 |
| removing | 95 |
| Blink code | 117-118 |
| Brake discs | |
| checking | 82 |
| Brake fluid | |
| front brake, adding | 82 |
| rear brake, adding | 86 |
| Brake fluid level | |
| front brake, checking | 82 |
| rear brake, checking | 86 |
| Brake linings | |
| front brake, changing | 84 |
| front brake, checking | 83 |
| rear brake, changing | 88 |
| rear brake, checking | 87 |
| Brake system | 81-89 |
| C | |
| Capacity | |
| coolant | 105, 121 |
| engine oil | 110, 121 |
| fuel | 45, 121 |
| Chain | |
| checking | 75 |
| cleaning | 74 |
| Chain guide | |
| checking | 75 |
| Chain tension | |
| adjusting | 75 |
| checking | 74 |
| Chassis number | 12 |
| Clutch | |
| fluid level, checking/correcting | 79 |
| fluid, changing | 79 |

| | |
|--|---------|
| Clutch lever | 14 |
| basic position, adjusting | 78 |
| Compression damping | |
| fork, adjusting | 52 |
| Compression damping, high-speed | |
| shock absorber, adjusting | 49 |
| Compression damping, low-speed | |
| shock absorber, adjusting | 48 |
| Coolant | |
| draining | 104 |
| refilling | 105 |
| Coolant level | |
| checking | 103-104 |
| Cooling system | 103 |
| Customer service | 9 |
| D | |
| Difficult riding conditions | 39 |
| dry sand | 40 |
| high temperature | 41 |
| low temperature | 41 |
| muddy surfaces | 41 |
| slow speed | 41 |
| snow | 41 |
| wet sand | 40 |
| wet surfaces | 41 |
| E | |
| Electric starter button | 16 |
| Emergency OFF switch | 15 |
| Engine | |
| running-in | 39 |
| Engine guard | |
| installing | 80 |
| removing | 80 |
| Engine number | 12 |
| Engine oil | |
| adding | 111 |
| changing | 109 |
| Engine oil level | |
| checking | 108 |
| Engine sprocket | |
| checking | 75 |
| Environment | 7 |
| F | |
| Figures | 9 |
| Filler cap | |
| closing | 17 |
| opening | 17 |
| Filling up | |
| fuel | 45 |
| Foot brake lever | 19 |
| basic position, adjusting | 85 |
| free travel, checking | 85 |
| Fork legs | |
| basic setting, checking | 52 |
| bleeding | 56 |

| | |
|--------------------------------------|--------|
| dust boots, cleaning | 56 |
| installing | 58 |
| removing | 57 |
| spring preload, adjusting | 54 |
| Fork protector | |
| installing | 59 |
| removing | 59 |
| Frame | |
| checking | 77 |
| Front fender | |
| installing | 66 |
| removing | 66 |
| Front wheel | |
| installing | 90 |
| removing | 90 |
| Fuel screen | |
| changing | 108 |
| Fuel tank | |
| installing | 72 |
| removing | 71 |
| Fuse | |
| individual power consumers, changing | 98 |
| main fuse, changing | 97 |
| H | |
| Hand brake lever | 14 |
| basic position, adjusting | 81 |
| free travel, adjusting | 81 |
| free travel, checking | 81 |
| Handlebar position | 54 |
| adjusting | 54 |
| Headlight | |
| headlight range, adjusting | 100 |
| Headlight bulb | |
| changing | 99 |
| Headlight mask with headlight | |
| installing | 99 |
| removing | 98 |
| Headlight setting | |
| checking | 100 |
| Horn button | 15 |
| I | |
| Idle speed | |
| adjusting | 107 |
| Idle speed adjusting screw | 18 |
| Intended use | 6 |
| K | |
| Key number | 12 |
| Kick starter | 18 |
| Kill switch | 14 |
| L | |
| Light switch | 15 |
| Lower triple clamp | |
| installing | 61, 63 |
| removing | 59-60 |

| | |
|--|-------|
| M | |
| Main fuse | |
| changing | 97 |
| Main silencer | |
| glass fiber yarn filling, changing | 70 |
| installing | 70 |
| removing | 70 |
| Motorcycle | |
| cleaning | 112 |
| raising with lift stand | 56 |
| removing from lift stand | 56 |
| O | |
| Oil filter | |
| changing | 109 |
| Oil screen | |
| cleaning | 109 |
| Operating substances | 9 |
| Overview of indicator lamps | 16 |
| Owner's Manual | 8 |
| P | |
| Play in throttle cable | |
| checking | 106 |
| Preparing for use | |
| advice on first use | 38 |
| after storage | 114 |
| checks and maintenance work when preparing for use | 42 |
| Protective clothing | 7 |
| R | |
| Rear sprocket | |
| checking | 75 |
| Rear wheel | |
| installing | 92 |
| removing | 91 |
| Rebound damping | |
| fork, adjusting | 53 |
| shock absorber, adjusting | 49 |
| Riding sag | |
| adjusting | 51 |
| Rubber grip | |
| checking | 78 |
| securing | 78 |
| S | |
| Safe operation | 7 |
| Seat | |
| mounting | 68 |
| removing | 67 |
| Service | 9 |
| Service schedule | 46-47 |
| Shift lever | 18 |
| basic position, adjusting | 107 |
| basic position, checking | 107 |
| Shock absorber | |
| installing | 67 |
| removing | 67 |

- riding sag, checking 50
- spring preload, adjusting 51
- static sag, checking 50
- Side stand** 19
- Spare parts** 9
- Speedometer**
 - adjusting 22
 - battery, changing 101
 - clock, setting 22, 30
 - kilometers or miles, setting 21, 29
 - setting 29
 - speedometer overview 21, 28
- Spoke tension**
 - checking 93
- Starting** 42
- Steering**
 - locking 19
 - unlocking 20
- Steering head bearing**
 - greasing 66
- Steering head bearing play**
 - adjusting 65
 - checking 64
- Storage** 114
- Swingarm**
 - checking 77

T

- Technical data**
 - capacities 121
 - chassis 121
 - chassis tightening torques 124
 - electrical system 122
 - engine 119
 - engine tightening torques 119
 - fork 122
 - shock absorber 123
 - tires 122
- Throttle cable play**
 - adjusting 106
- Throttle cable routing**
 - checking 77
- Throttle grip** 14
- Tire air pressure**
 - checking 93
- Tire condition**
 - checking 92
- Transport** 44
- Troubleshooting** 115-116
- Turn signal bulb**
 - changing 101
- Turn signal switch** 15
- Type label** 12

U

- Use definition** 6

V

- View of vehicle**
 - front left 10
 - rear right 11

W

- Warranty** 9
- Winter operation**
 - checks and maintenance steps 113
- Work rules** 7



3213035en

04/2013

