

Freeride 350 EU
Freeride 350 AU

Art. no. 3213184en



KTM

DEAR KTM CUSTOMER

Congratulations on your decision to purchase a KTM motorcycle. You are now the owner of a state-of-the-art sports motorcycle that will give you enormous pleasure if you service and maintain it accordingly.

We wish you a lot of enjoyment in riding this vehicle.

Enter the serial numbers of your vehicle below.

Chassis number (☛ p. 10)	Dealer's stamp
Engine number (☛ p. 10)	
Key number (☛ p. 10)	

The Owner's Manual contained the latest information for this model series at the time of going to print. Slight deviations resulting from continuing development and design of the motorcycles can, however, not be completely excluded.

All specifications are non-binding. KTM Motorrad AG specifically reserves the right to modify or delete technical specifications, prices, colors, forms, materials, services, designs, equipment, etc., without prior notice and without specifying reasons, to adapt these to local conditions, as well as to stop production of a particular model without prior notice. KTM accepts no liability for delivery options, deviations from illustrations and descriptions, misprints, and other errors. The models portrayed partly contain special equipment that does not belong to the regular scope of supply.

© 2014 KTM Motorrad AG, Mattighofen Austria

All rights reserved

Reproduction, even in part, as well as copying of all kinds, is permitted only with the express written permission of the copyright owner.



ISO 9001(12 100 6061)

According to the international quality management standard ISO 9001, KTM uses quality assurance processes that lead to the maximum possible quality of the products.

Issued by: TÜV Management Service

REG.NO. 12 100 6061

KTM Motorrad AG

5230 Mattighofen, Austria





TABLE OF CONTENTS

1	MEANS OF REPRESENTATION	4	7.10	AVG average speed, ART operating hours, and ODO total distance covered	21
1.1	Symbols used	4	8	PREPARING FOR USE.....	22
1.2	Formats used.....	4	8.1	Advice on first use	22
2	SAFETY ADVICE.....	5	8.2	Running in the engine	23
2.1	Use definition - intended use	5	9	RIDING INSTRUCTIONS.....	24
2.2	Safety advice.....	5	9.1	Checks and maintenance work when preparing for use	24
2.3	Degrees of risk and symbols	5	9.2	Starting.....	24
2.4	Tampering warning.....	5	9.3	Starting off.....	25
2.5	Safe operation	6	9.4	Shifting, riding	25
2.6	Protective clothing	6	9.5	Applying the brakes.....	25
2.7	Work rules.....	6	9.6	Stopping, parking.....	26
2.8	Environment.....	6	9.7	Transport	26
2.9	Owner's Manual	6	9.8	Refueling	27
3	IMPORTANT NOTES.....	7	10	SERVICE SCHEDULE	28
3.1	Guarantee, warranty	7	10.1	Service schedule.....	28
3.2	Operating and auxiliary substances	7	10.2	Service work (as additional order)	29
3.3	Spare parts, accessories	7	11	TUNING THE CHASSIS	30
3.4	Service	7	11.1	Checking the basic chassis setting with the rider's weight.....	30
3.5	Figures	7	11.2	Compression damping of the shock absorber.....	30
3.6	Customer service.....	7	11.3	Adjusting the low-speed compression damping of the shock absorber	30
4	VIEW OF VEHICLE	8	11.4	Adjusting the high-speed compression damping of the shock absorber.....	31
4.1	View of vehicle, front left (example)	8	11.5	Adjusting the rebound damping of the shock absorber.....	31
4.2	View of vehicle, rear right (example)	9	11.6	Measuring rear wheel sag unloaded.....	32
5	SERIAL NUMBERS	10	11.7	Checking the static sag of the shock absorber....	32
5.1	Chassis number	10	11.8	Checking the riding sag of the shock absorber....	33
5.2	Type label	10	11.9	Adjusting the spring preload of the shock absorber 🖱.....	33
5.3	Key number.....	10	11.10	Adjusting the riding sag 🖱.....	34
5.4	Engine number	10	11.11	Checking the basic setting of the fork	34
5.5	Fork part number	10	11.12	Adjusting the compression damping of the fork	35
5.6	Shock absorber part number	11	11.13	Adjusting the rebound damping of the fork.....	35
6	CONTROLS.....	12	11.14	Handlebar position.....	35
6.1	Clutch lever.....	12	11.15	Adjusting the handlebar position 🖱.....	36
6.2	Hand brake lever.....	12	12	SERVICE WORK ON THE CHASSIS.....	37
6.3	Throttle grip	12	12.1	Raising the motorcycle with the lift stand.....	37
6.4	Kill switch	12	12.2	Removing the motorcycle from the lift stand.....	37
6.5	Horn button.....	12	12.3	Bleeding the fork legs.....	37
6.6	Light switch	13	12.4	Cleaning the dust boots of the fork legs.....	38
6.7	Turn signal switch.....	13	12.5	Removing the fork legs 🖱.....	38
6.8	Emergency OFF switch (Freeride 350 AU)	13	12.6	Installing the fork legs 🖱.....	39
6.9	Electric starter button (Freeride 350 EU)	13	12.7	Removing the fork protector	39
6.10	Electric starter button (Freeride 350 AU)	13	12.8	Installing the fork protector.....	40
6.11	Overview of indicator lamps	14	12.9	Removing the lower triple clamp 🖱.....	40
6.12	Opening the filler cap.....	14	12.10	Installing the lower triple clamp 🖱.....	41
6.13	Closing the filler cap	14	12.11	Checking the steering head bearing play.....	42
6.14	Idle speed adjusting screw	15	12.12	Adjusting the play of the steering head bearing 🖱.....	43
6.15	Shift lever	15	12.13	Greasing the steering head bearing 🖱.....	43
6.16	Foot brake lever	15	12.14	Removing the front fender	44
6.17	Side stand.....	16	12.15	Installing the front fender	44
6.18	Steering lock	16	12.16	Removing the shock absorber 🖱.....	44
6.19	Locking the steering.....	16	12.17	Installing the shock absorber 🖱.....	44
6.20	Unlocking the steering.....	17	12.18	Folding the seat up	45
7	SPEEDOMETER	18	12.19	Locking the seat	45
7.1	Overview	18	12.20	Taking off the spoiler.....	45
7.2	Activation.....	18	12.21	Mounting the spoiler	46
7.3	Message on the speedometer	18			
7.4	Setting the speedometer.....	18			
7.5	Setting kilometers or miles.....	19			
7.6	Setting the clock.....	20			
7.7	Setting the service display	20			
7.8	Speed, time, and DST distance 1	21			
7.9	Speed, time, and DST2 distance 2	21			

12.22	Removing the air filter housing	46	15.6	Removing the headlight mask with the headlight	78
12.23	Installing the air filter housing	47	15.7	Refitting the headlight mask with the headlight	78
12.24	Removing the air filter	47	15.8	Changing the headlight bulb	79
12.25	Installing the air filter	47	15.9	Changing the turn signal bulb	80
12.26	Cleaning the air filter and air filter housing	48	15.10	Checking the headlight setting	80
12.27	Removing the main silencer	48	15.11	Adjusting the headlight range	80
12.28	Installing the main silencer	49	15.12	Changing the speedometer battery	81
12.29	Changing the glass fiber yarn filling of the main silencer	50	16	COOLING SYSTEM	82
12.30	Removing the fuel tank	50	16.1	Cooling system	82
12.31	Installing the fuel tank	51	16.2	Checking the antifreeze and coolant level	82
12.32	Checking for chain dirt accumulation	53	16.3	Checking the coolant level	83
12.33	Cleaning the chain	53	16.4	Draining the coolant	83
12.34	Checking the chain tension	53	16.5	Refilling coolant	84
12.35	Adjusting the chain tension	54	17	TUNING THE ENGINE	85
12.36	Checking the chain, rear sprocket, engine sprocket and chain guide	55	17.1	Checking the play in the throttle cable	85
12.37	Checking the frame	56	17.2	Adjusting the play in the throttle cable	85
12.38	Checking the swingarm	57	17.3	Adjusting the idle speed	86
12.39	Checking the throttle cable routing	57	17.4	Checking the basic position of the shift lever	86
12.40	Checking the rubber grip	57	17.5	Adjusting the basic position of the shift lever	86
12.41	Additionally securing the rubber grip	58	18	SERVICE WORK ON THE ENGINE	87
12.42	Adjusting the basic position of the clutch lever	58	18.1	Changing the fuel screen	87
12.43	Checking fluid level of the hydraulic clutch	58	18.2	Checking the engine oil level	87
12.44	Correcting the fluid level of the hydraulic clutch	58	18.3	Changing the engine oil and oil filter, cleaning the oil screen	88
12.45	Changing the hydraulic clutch fluid	59	18.4	Adding engine oil	90
12.46	Removing the engine guard	60	19	CLEANING, CARE	91
12.47	Installing the engine guard	60	19.1	Cleaning the motorcycle	91
13	BRAKE SYSTEM	61	19.2	Checks and maintenance steps for winter operation	92
13.1	Checking the free travel of the hand brake lever	61	20	STORAGE	93
13.2	Adjusting the free travel of the handbrake lever	61	20.1	Storage	93
13.3	Checking the brake discs	61	20.2	Preparing for use after storage	93
13.4	Checking the brake fluid level of the front brake	62	21	TROUBLESHOOTING	94
13.5	Adding front brake fluid	62	22	FLASH CODE	96
13.6	Checking the front brake linings	63	23	TECHNICAL DATA	97
13.7	Changing the front brake linings	63	23.1	Engine	97
13.8	Checking the free travel of foot brake lever	65	23.2	Engine tightening torques	97
13.9	Adjusting the basic position of the foot brake lever	65	23.3	Capacities	99
13.10	Checking the rear brake fluid level	66	23.3.1	Engine oil	99
13.11	Adding rear brake fluid	66	23.3.2	Coolant	99
13.12	Checking the rear brake linings	67	23.3.3	Fuel	99
13.13	Changing the rear brake linings	67	23.4	Chassis	99
14	WHEELS, TIRES	70	23.5	Electrical system	100
14.1	Removing the front wheel	70	23.6	Tires	100
14.2	Installing the front wheel	70	23.7	Fork	100
14.3	Removing the rear wheel	71	23.8	Shock absorber	101
14.4	Installing the rear wheel	71	23.9	Chassis tightening torques	101
14.5	Checking the tire condition	72	24	SUBSTANCES	103
14.6	Checking the tire air pressure	73	25	AUXILIARY SUBSTANCES	105
14.7	Checking the spoke tension	73	26	STANDARDS	107
15	ELECTRICAL SYSTEM	74	INDEX		108
15.1	Removing the battery	74			
15.2	Installing the battery	74			
15.3	Recharging the battery	75			
15.4	Changing the main fuse	76			
15.5	Changing the fuses of individual power consumers	77			

1.1 Symbols used

The meaning of specific symbols is described below.

	Indicates an expected reaction (e.g. of a work step or a function).
	Indicates an unexpected reaction (e.g. of a work step or a function).
	All work marked with this symbol requires specialist knowledge and technical understanding. In the interest of your own safety, have these jobs performed by an authorized KTM workshop. There, your motorcycle will be optimally cared for by specially trained experts using the specialist tools required.
	Indicates a page reference (more information is provided on the specified page).

1.2 Formats used

The typographical formats used in this document are explained below.

Specific name	Identifies a proprietary name.
Name®	Identifies a protected name.
Brand™	Identifies a brand available on the open market.

2.1 Use definition - intended use

KTM sport motorcycles are designed and built to withstand the normal stresses and strains of offroad use.



Info

The motorcycle is authorized for public road traffic in the homologous (reduced) version only. In the derestricted version, the motorcycle must be used only on closed off property remote from public road traffic. The motorcycle is designed for trial riding and difficult offroad terrain and not for motocross.

2.2 Safety advice

A number of safety instructions need to be followed to operate the vehicle safely. Therefore, read this manual carefully. The safety instructions are highlighted in the text and are referred to at the relevant passages.



Info

The vehicle has various information and warning labels at prominent locations. Do not remove information/warning labels. If they are missing, you or others may not recognize dangers and may therefore be injured.

2.3 Degrees of risk and symbols



Danger

Identifies a danger that will immediately and invariably lead to fatal or serious permanent injury if the appropriate measures are not taken.



Warning

Identifies a danger that is likely to lead to fatal or serious injury if the appropriate measures are not taken.



Caution

Identifies a danger that may lead to minor injuries if the appropriate measures are not taken.

Note

Identifies a danger that will lead to considerable machine and material damage if the appropriate measures are not taken.



Warning

Identifies a danger that will lead to environmental damage if the appropriate measures are not taken.

2.4 Tampering warning



Tampering with the noise control system is prohibited. Federal law prohibits the following acts or the causing thereof:

- 1 The removal or rendering inoperative by any person other than for purposes of maintenance, repair, or replacement, of any device or element of design incorporated into any new vehicle for the purpose of noise control prior to its sale or delivery to the ultimate purchaser or while it is in use, or
- 2 the use of the vehicle after such device or element of design has been removed or rendered inoperative by any person.

Among those acts presumed to constitute tampering are the acts listed below:

- 1 Removal or puncturing of the main silencer, baffles, header pipes or any other components which conduct exhaust gases.
- 2 Removal or puncturing of parts of the intake system.
- 3 Lack of proper maintenance.
- 4 Replacing moving part of the vehicle, or parts of the exhaust or intake system, with parts other than those specified by the manufacturer.

2.5 Safe operation

-  **Danger**
Danger of accidents Danger arising from the rider's judgement being impaired.
- Do not operate the vehicle while under the influence of alcohol, drugs and certain medications or physically or mentally impaired.
-  **Danger**
Danger of poisoning Exhaust gases are toxic and inhaling them may result in unconsciousness and/or death.
- When running the engine, always make sure there is sufficient ventilation, and do not start or run the engine in an enclosed space without an effective exhaust extraction system.
-  **Warning**
Danger of burns Some vehicle components become very hot when the vehicle is operated.
- Do not touch hot components such as exhaust system, radiator, engine, shock absorber, and the brake system. Allow these components to cool down before starting work on them.

Only operate the vehicle when it is in perfect technical condition, in accordance with its intended use, and in a safe and environmentally compatible manner.

An appropriate driver's license is needed to ride the vehicle on public roads.

Have malfunctions that impair safety promptly eliminated by an authorized KTM workshop.

Adhere to the information and warning labels on the vehicle.

2.6 Protective clothing

-  **Warning**
Risk of injury Missing or poor protective clothing presents an increased safety risk.
- Wear protective clothing (helmet, boots, gloves, pants and jacket with protectors) every time you ride the vehicle. Always wear protective clothing that is in good condition and meets the legal requirements.

In the interest of your own safety, KTM recommends that you only operate the vehicle while wearing protective clothing.

2.7 Work rules

Special tools are necessary for certain tasks. The tools are not contained in the vehicle but can be ordered under the number in parentheses. E.g.: bearing puller (15112017000)

During assembly, non-reusable parts (e.g. self-locking screws and nuts, seals and seal rings, O-rings, pins, lock washers) must be replaced by new parts.

In some instances, a thread locker (e.g. **Loctite**®) is required. The manufacturer instructions for use must be followed.

After disassembly, clean the parts that are to be reused and check them for damage and wear. Change damaged or worn parts.

After you complete the repair or service work, check the operating safety of the vehicle.

2.8 Environment

If you use your motorcycle responsibly, you can ensure that problems and conflicts do not occur. To protect the future of the motorcycle sport, make sure that you use your motorcycle legally, display environmental consciousness, and respect the rights of others.

When disposing of used oil, other operating and auxiliary fluids, and used components, comply with the laws and regulations of the respective country.

Because motorcycles are not subject to the EU regulations governing the disposal of used vehicles, there are no legal regulations that pertain to the disposal of an end-of-life motorcycle. Your authorized KTM dealer will be glad to advise you.

2.9 Owner's Manual

It is important that you read this Owner's Manual carefully and completely before making your first trip. The Owner's Manual contains useful information and many tips on how to operate, handle, and maintain your motorcycle. Only then will you find out how to customize the vehicle ideally for your own use and how you can protect yourself from injury.

Keep the Owner's Manual in an accessible place to enable you to refer to it as needed.

If you would like to know more about the vehicle or have questions on the material you read, please contact an authorized KTM dealer. The Owner's Manual is an important component of the vehicle and should be handed over to the new owner if the vehicle is sold.

3.1 Guarantee, warranty

The work prescribed in the service schedule must be carried out by an authorized KTM workshop only and confirmed in the customer's Service & Warranty Booklet and in the **KTM Dealer.net**; otherwise, all warranty claims will be void. No warranty claims can be considered for damage resulting from manipulations and/or alterations to the vehicle.

Additional information on the guarantee or warranty and the procedures involved can be found in the Service & Warranty Booklet.

3.2 Operating and auxiliary substances



Warning

Environmental hazard Improper handling of fuel is a danger to the environment.

- Do not allow fuel to get into the ground water, the ground, or the sewage system.

Use operating and auxiliary substances (such as fuel and lubricants) as specified in the Owner's Manual.

3.3 Spare parts, accessories

For your own safety, only use spare parts and accessory products that are approved and/or recommended by KTM and have them installed by an authorized KTM workshop. KTM accepts no liability for other products and any resulting damage or loss. Certain spare parts and accessory products are specified in parentheses in the descriptions. Your authorized KTM dealer will be glad to advise you.

The current **KTM PowerParts** for your vehicle can be found on the KTM website.

International KTM Website: <http://www.ktm.com>

3.4 Service

A prerequisite for perfect operation and prevention of premature wear is that the service, care, and tuning work on the engine and chassis is properly carried out as described in the Owner's Manual. Incorrect adjustment and tuning of the engine and chassis can lead to damage and breakage of components.

Use of the vehicle under difficult conditions, such as on sand or on wet and muddy surfaces, can lead to considerably more rapid wear of components such as the drive train, brake system, or suspension components. For this reason, it may be necessary to inspect or replace parts before the next scheduled service.

It is imperative that you adhere to the stipulated run-in times and service intervals. If you observe these exactly, you will ensure a much longer service life for your motorcycle.

3.5 Figures

The figures contained in the manual may depict special equipment.

In the interest of clarity, some components may be shown disassembled or may not be shown at all. It is not always necessary to disassemble the component to perform the activity in question. Please follow the instructions in the text.

3.6 Customer service

Your authorized KTM dealer will be happy to answer any questions you may have on your vehicle and KTM.

A list of authorized KTM dealers can be found on the KTM website.

International KTM Website: <http://www.ktm.com>

4.1 View of vehicle, front left (example)



1	Speedometer
2	Clutch lever (☛ p. 12)
3	Filler cap
4	Seat
5	Seat release
6	Shock absorber compression adjustment
7	Shock absorber rebound adjustment
8	Side stand (☛ p. 16)
9	Battery
10	Shift lever (☛ p. 15)
11	Idle speed adjusting screw (☛ p. 15)
12	Steering lock (☛ p. 16)

4.2 View of vehicle, rear right (example)



M00466-10

1	Kill switch (☛ p. 12)
1	Horn button (☛ p. 12)
1	Light switch (☛ p. 13)
1	Turn signal switch (☛ p. 13)
2	Electric starter button (☛ p. 13)
3	Throttle grip (☛ p. 12)
4	Hand brake lever (☛ p. 12)
5	Fork rebound adjustment
6	Fork compression adjustment
7	Foot brake lever (☛ p. 15)
8	Level viewer for brake fluid, rear

5.1 Chassis number

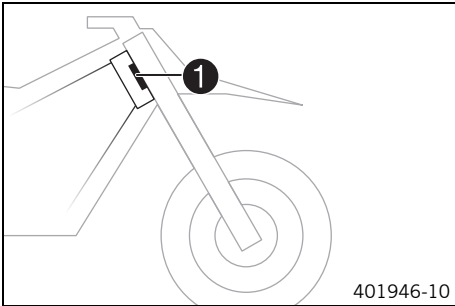

The chassis number ① is stamped on the right side of the steering head.

5.2 Type label

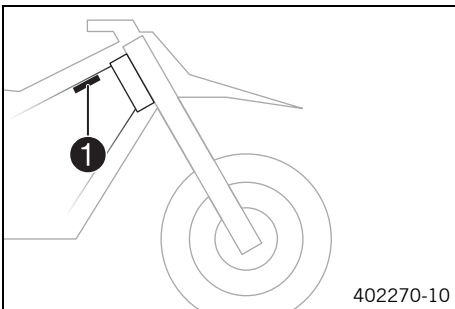

The type label ① is mounted on the frame at the front right.

5.3 Key number

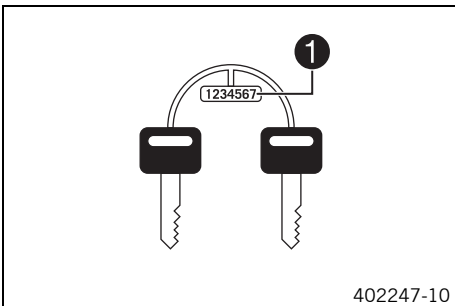

The key number ① for the steering lock is stamped onto the key connector.

5.4 Engine number

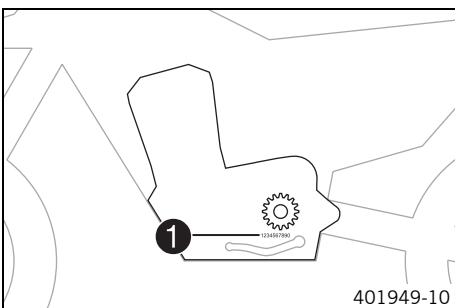

The engine number ① is stamped on the left side of the engine under the engine sprocket.

5.5 Fork part number

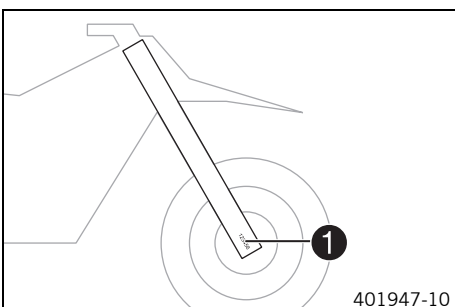

The fork part number ① is stamped on the inner side of the axle clamp.

5.6 Shock absorber part number

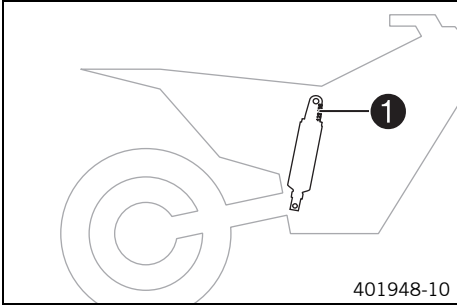

The shock absorber part number ① is stamped on the top of the shock absorber above the adjusting ring on the engine side.

6.1 Clutch lever

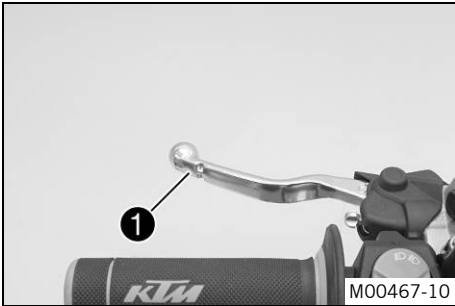

The clutch lever **1** is fitted on the left side of the handlebar. The clutch is hydraulically operated and self-adjusting.

6.2 Hand brake lever



The hand brake lever **1** is fitted on the right side of the handlebar. The front brake is engaged using the hand brake lever.

6.3 Throttle grip





The throttle grip **1** is fitted on the right side of the handlebar.

6.4 Kill switch



Kill switch **1** is fitted on the left side of the handlebar.

Possible states

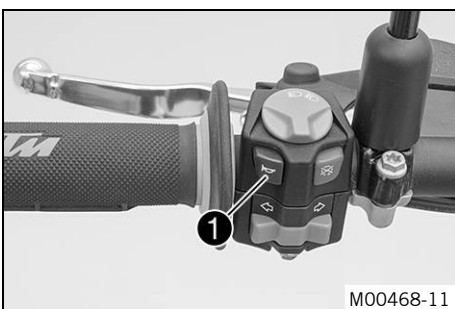

- Kill switch  in basic position – In this position, the ignition circuit is closed and the engine can be started.
- Kill switch  pressed – In this position, the ignition circuit is interrupted, a running engine stops, and a non-running engine will not start.

6.5 Horn button



The horn button **1** is fitted on the left side of the handlebar.

Possible states

- Horn button  in neutral position
- Horn button  pressed – The horn is operated in this position.

6.6 Light switch

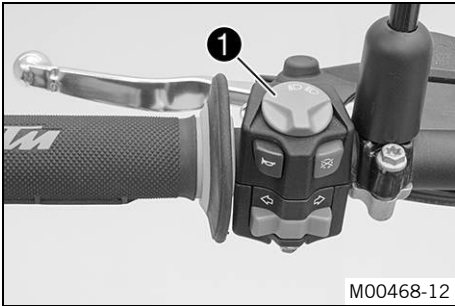

The light switch ❶ is fitted on the left side of the handlebar.

Possible states

	Low beam on – Light switch is in the central position. In this position, the low beam and tail light are switched on.
	High beam on – The light switch is turned counterclockwise. In this position, the high beam and the tail light are switched on.

6.7 Turn signal switch

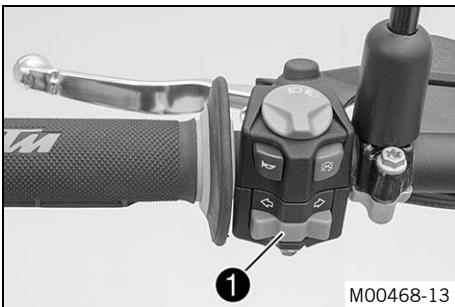

Turn signal switch ❶ is fitted on the left side of the handlebar.

Possible states

	Turn signal light off – Turn signal switch is in the central position.
	Turn signal light, left, on – Turn signal switch is turned to the left.
	Turn signal light, right, on – Turn signal switch is turned to the right.

6.8 Emergency OFF switch (Freeride 350 AU)



The emergency OFF switch ❶ is fitted on the right side of the handlebar.

Possible states

	Ignition off – In this position, the ignition circuit is interrupted, a running engine stops, and a non-running engine will not start.
	Ignition on – In this position, the ignition circuit is closed and the engine can be started.

6.9 Electric starter button (Freeride 350 EU)



Electric starter button ❶ is fitted on the right side of the handlebar.

Possible states

- Electric starter button ❶ in basic position
- Electric starter button ❶ pressed – In this position, the electric starter is actuated.

6.10 Electric starter button (Freeride 350 AU)



Electric starter button ❶ is fitted on the right side of the handlebar.

Possible states

- Electric starter button ❶ in basic position
- Electric starter button ❶ pressed – In this position, the electric starter is actuated.

6.11 Overview of indicator lamps



602795-01

Possible states

	High beam indicator light lights up blue – High beam is switched on.
	FI warning lamp (MIL) lights up/flashes orange – The OBD has detected an emission- or safety-critical fault.
	The fuel level warning lamp lights up orange – The fuel level has reached the reserve mark.
	Turn signal indicator light flashes green – Turn signal is switched on.

6.12 Opening the filler cap



Danger

Fire hazard Fuel is highly flammable.

- Never refuel the vehicle near open flames or burning cigarettes, and always switch off the engine first. Be careful that no fuel is spilt, especially on hot vehicle components. Clean up spilt fuel immediately.
- The fuel in the fuel tank expands when warm and may emerge if overfilled. Follow the instructions on refueling.



Warning

Danger of poisoning Fuel is poisonous and a health hazard.

- Fuel must not come into contact with the skin, eyes, or clothing. Do not breathe in the fuel vapors. If contact occurs with the eyes, rinse with water immediately and contact a physician. Immediately clean contaminated areas on the skin with soap and water. If fuel is swallowed, contact a physician immediately. Change clothing that is contaminated with fuel. Store fuel properly in a suitable canister and keep away from children.



Warning

Environmental hazard Improper handling of fuel is a danger to the environment.

- Do not allow fuel to get into the ground water, the ground, or the sewage system.

Preparatory work

- Fold the seat up. (☛ p. 45)

Main work

- Press release button **1**, turn the filler cap counterclockwise, and lift it free.

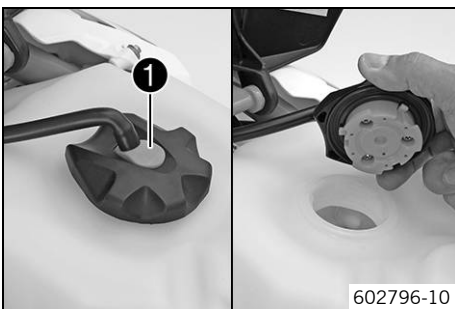

602796-10

6.13 Closing the filler cap

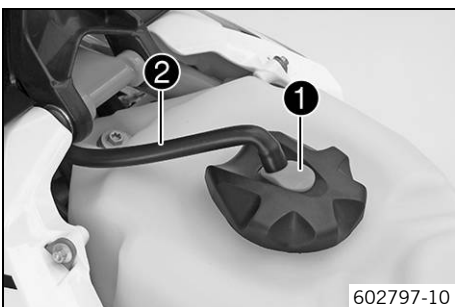

602797-10

Main work

- Replace the filler cap and turn clockwise until the release button **1** locks in place.



Info

Run the fuel tank breather hose **2** without kinks.

Finishing work

- Lock the seat. (☛ p. 45)

6.14 Idle speed adjusting screw



Idle speed adjusting screw **1** is located on the throttle valve body at the top left. The idle speed adjusting screw has two functions. Turning it controls the idle speed. Pulling it out all the way raises the idle speed during a cold start.

Possible states

- RPM increase activated – Idle speed adjusting screw is pulled out all the way.
- RPM increase deactivated – Idle speed adjusting screw is pushed in all the way.

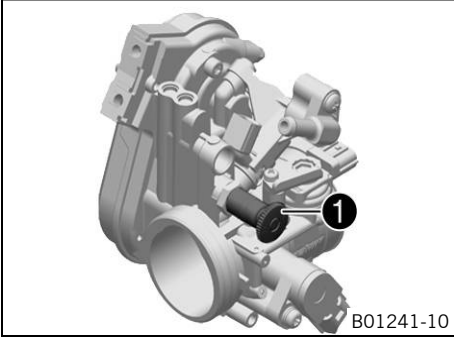

6.15 Shift lever

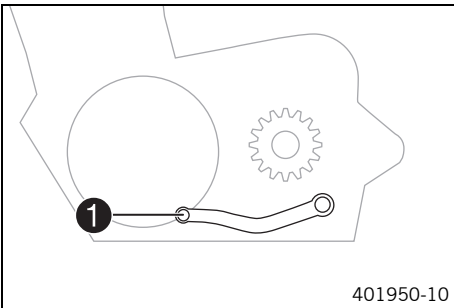

Shift lever **1** is mounted on the left side of the engine.

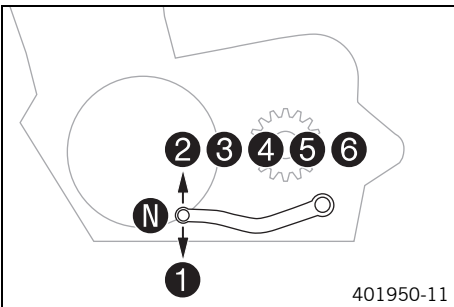

The gear positions can be seen in the photograph. The neutral or idle position is between the first and second gears.

6.16 Foot brake lever

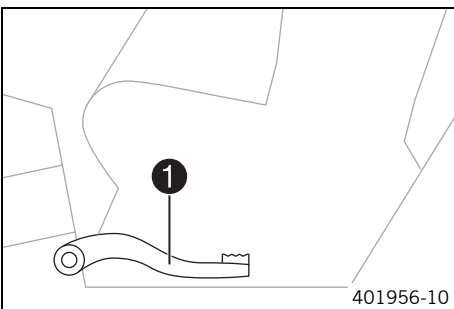

Foot brake lever **1** is located in front of the right footrest. The foot brake lever is used to activate the rear brake.

6.17 Side stand

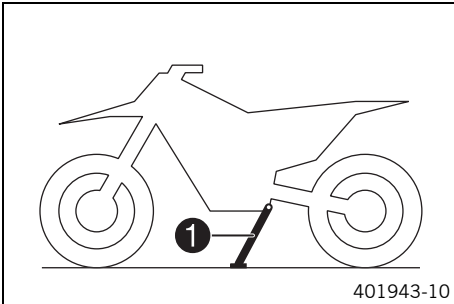

The side stand **1** is on the left side of the vehicle.

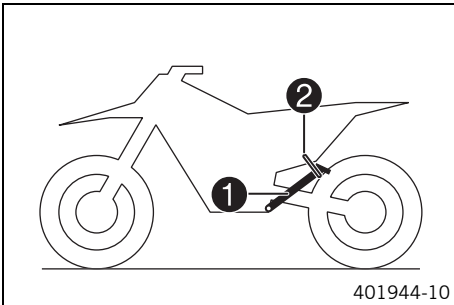

The side stand is used to park the motorcycle.

i Info
When you are riding, side stand **1** must be folded up and secured with rubber band **2**.

6.18 Steering lock

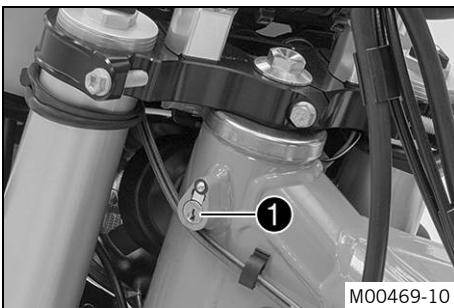

Steering lock **1** is fitted on the left side of the steering head.

The steering lock is used to lock the steering. Steering, and therefore riding, is no longer possible.

6.19 Locking the steering

Note

Danger of damage The parked vehicle may roll away or fall over.

- Always place the vehicle on a firm and even surface.

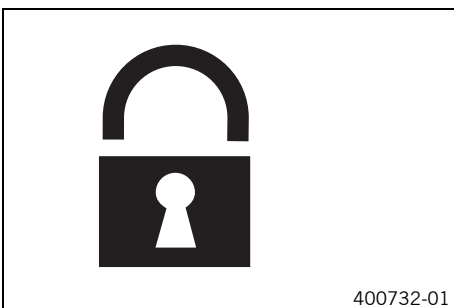

- Park the vehicle.
- Turn the handlebar as far as possible to the right.
- Insert the key in the steering lock, turn it to the left, press it in, and turn it to the right. Remove the key.
- ✓ Steering is no longer possible.

i Info
Never leave the key in the steering lock.

6.20 Unlocking the steering



- Insert the key in the steering lock, turn it to the left, pull it out, and turn it to the right. Remove the key.
✓ You can now steer the bike again.



Info

Never leave the key in the steering lock.

7.1 Overview

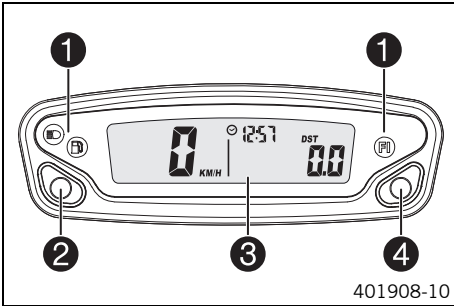

1	Overview of indicator lamps (☛ p. 14)
2	Left button
3	Display
4	Right button

7.2 Activation

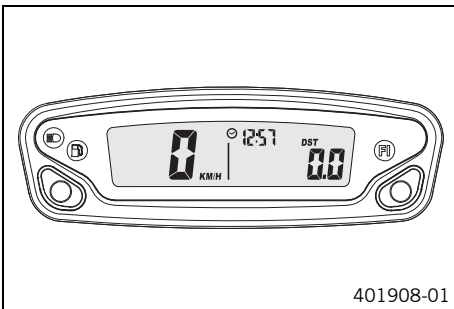

Activating the speedometer

The speedometer is activated when one of the buttons is pressed or an impulse comes from the wheel speed sensor.

7.3 Message on the speedometer

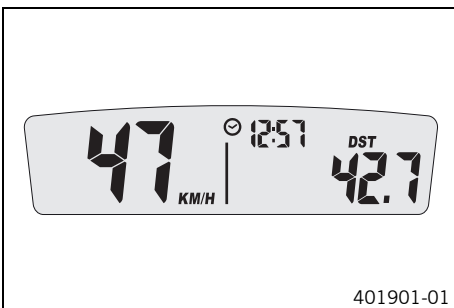

Possible states

	Battery voltage of the speedometer – Battery voltage of the speedometer is too low. Change the battery.
	Service – A service is due. Contact an authorized KTM workshop.

7.4 Setting the speedometer

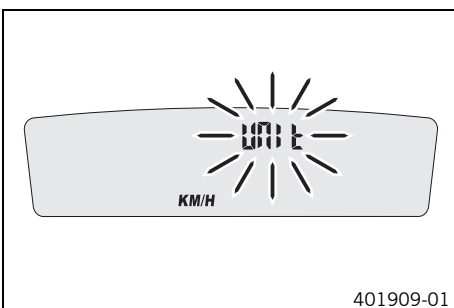

Condition

The motorcycle is stationary.

- Press both buttons for 3–5 seconds.
 - ✓ The Setup menu is displayed. The **UNIT** display flashes.
- Press one of the buttons to select **UNIT** for the speed in kilometers **KM/H** or miles **M/H**.

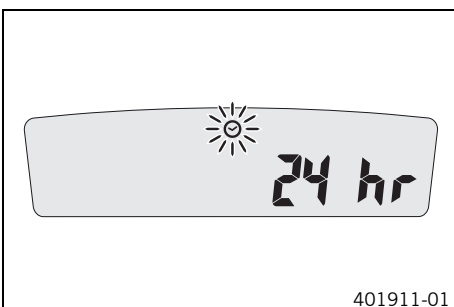

- Wait for 5 seconds.
 - ✓ The speedometer changes to the next menu item. The ☉ symbol flashes.
- Press one of the buttons to select the 24h or 12h display of the clock.

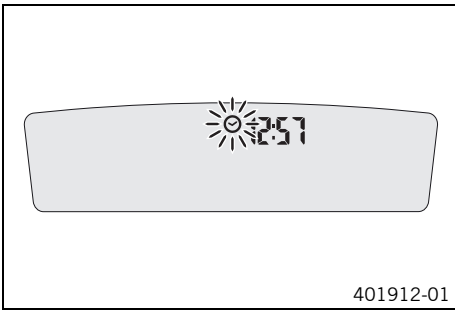

- Wait for 5 seconds.
- ✓ The speedometer changes to the next menu item. The ☀ symbol flashes.

Resetting the time

- Press the left button.
- ✓ The value decreases.

Advancing the time

- Press the right button.
- ✓ The value increases.

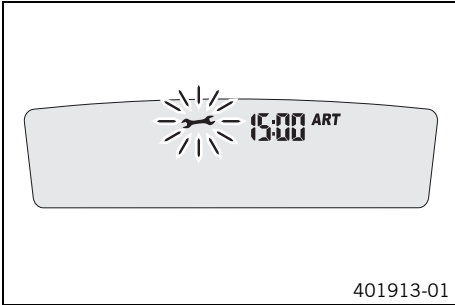

- Wait for 5 seconds.
- ✓ The speedometer changes to the next menu item. The ☀ symbol flashes.
- Set the service.

Guideline

One-time service after	1 h
Service every	20 h

Shortening the service interval

- Press the left button.
- ✓ The value decreases.

Extending the service interval

- Press the right button.
- ✓ The value increases.

Switching off the service interval display

- Press and hold the left button.
- ✓ The value decreases rapidly until **off** appears in the display.

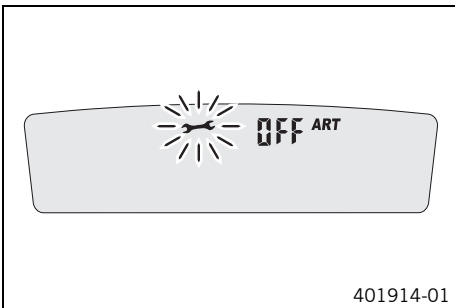

7.5 Setting kilometers or miles



Info

If you change the unit of measure, the **ODO** value is retained and converted accordingly.

Condition

The motorcycle is stationary.

- Press both buttons for 3–5 seconds.
- ✓ The Setup menu is displayed. The **UNIT** display flashes.
- Press one of the buttons to select **UNIT** for the speed in kilometers **KM/H** or miles **M/H**.

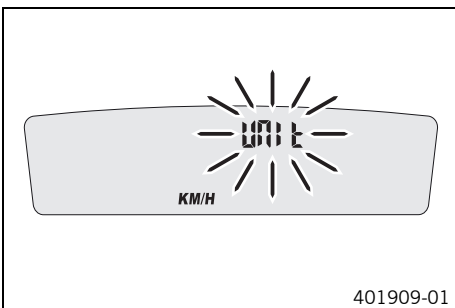

7.6 Setting the clock

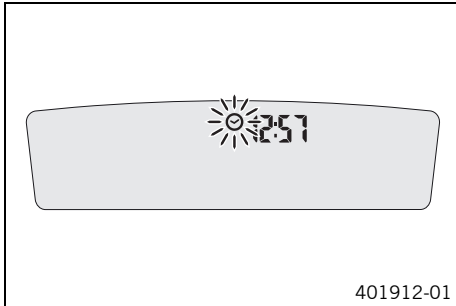
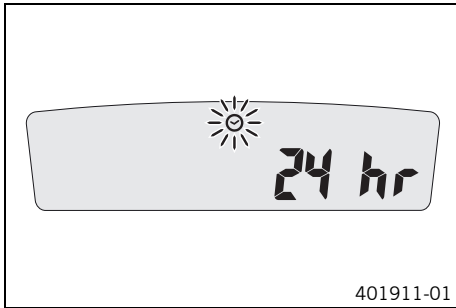

Condition

The motorcycle is stationary.

- Press both buttons for 3–5 seconds.
 - ✓ The Setup menu is displayed. The **UNIT** display flashes.
- Wait for the menu of the clock ☀ to flash.
- Press one of the buttons to select the 24h or 12h display of the clock.

- Wait for 5 seconds.

✓ The speedometer changes to the next menu item. The ☀ symbol flashes.

Resetting the time

- Press the left button.
 - ✓ The value decreases.

Advancing the time

- Press the right button.
 - ✓ The value increases.

7.7 Setting the service display

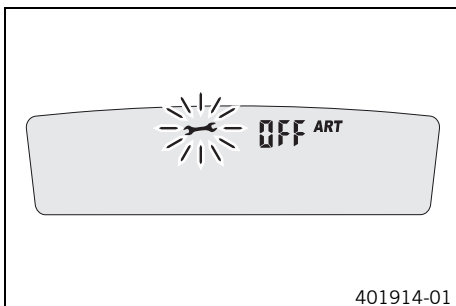
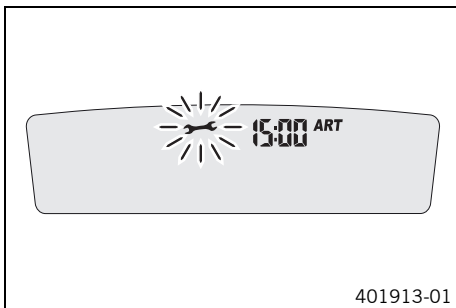

Condition

The motorcycle is stationary.

- Press both buttons for 3–5 seconds.
 - ✓ The Setup menu is displayed. The **UNIT** display flashes.
- Wait for the menu of the service display ⚙ to flash.
- Set the service.

Guideline

One-time service after	1 h
Service every	20 h

Shortening the service interval

- Press the left button.
 - ✓ The value decreases.

Extending the service interval

- Press the right button.
 - ✓ The value increases.

Switching off the service interval display

- Press and hold the left button.
 - ✓ The value decreases rapidly until **off** appears in the display.

7.8 Speed, time, and DST distance 1

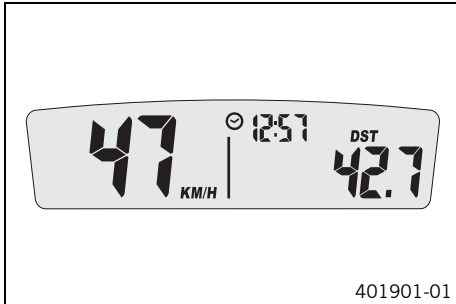

- Press one of the buttons until **DST** appears on the speedometer.
- KM/H** or **M/H** shows the speed.
 ⌚ shows the time.
DST shows the distance since the last reset, such as between two refueling stops.

i Info
 If the value of 39999.9 is exceeded, **DST** is automatically reset to 0.0.

Press the left button briefly.	Next display mode
Press the left button for 3 – 5 seconds.	DST can be preset to a value between 0.0 and 39999.9 by pressing the buttons.
Press the right button briefly.	Next display mode
Press the right button for 3 – 5 seconds.	DST is reset to 0.0.

7.9 Speed, time, and DST2 distance 2

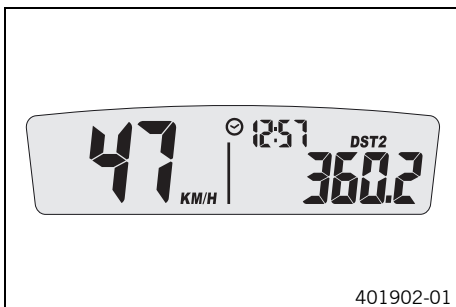

- Press one of the buttons until **DST2** appears on the speedometer.
- KM/H** or **M/H** shows the speed.
 ⌚ shows the time.
DST2 shows the distance 2 since the last reset, such as between two refueling stops.

i Info
 If the value of 39999.9 is exceeded, **DST2** is automatically reset to 0.0.

Press the left button briefly.	Next display mode
Press the left button for 3 – 5 seconds.	DST2 can be preset to a value between 0.0 and 39999.9 by pressing the buttons.
Press the right button briefly.	Next display mode
Press the right button for 3 – 5 seconds.	DST2 is reset to 0.0.

7.10 AVG average speed, ART operating hours, and ODO total distance covered

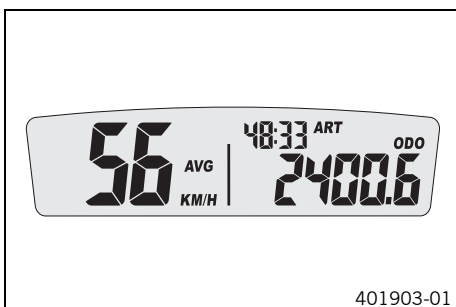

- Press one of the buttons until **AVG**, **ART** and **ODO** appear in the speedometer.
- AVG** shows the average speed since the last reset.
ART shows the operating hours.
ODO shows the total distance covered.

Press the left button briefly.	Next display mode
Press the left button for 3 – 5 seconds.	The OPEN END WRENCH SYMBOL shows the remaining operating hours until the next service is due.
Press the right button briefly.	Next display mode
Press the right button for 3 – 5 seconds.	AVG is reset to 0.0.

8.1 Advice on first use

**Danger****Danger of accidents** Danger arising from the rider's judgement being impaired.

- Do not operate the vehicle while under the influence of alcohol, drugs and certain medications or physically or mentally impaired.

**Warning****Risk of injury** Missing or poor protective clothing presents an increased safety risk.

- Wear protective clothing (helmet, boots, gloves, pants and jacket with protectors) every time you ride the vehicle. Always wear protective clothing that is in good condition and meets the legal requirements.

**Warning****Danger of crashing** Poor vehicle handling due to different tire tread patterns on front and rear wheels.

- The front and rear wheels must be fitted with tires with similar tread patterns to prevent loss of control over the vehicle.

**Warning****Danger of accidents** Critical riding behavior due to inappropriate riding.

- Adapt your riding speed to the road conditions and your riding ability.

**Warning****Danger of accidents** Accident risk caused by presence of a passenger.

- Your vehicle is not designed to carry passengers. Do not ride with a passenger.

**Warning****Danger of accidents** Failure of brake system.

- If the foot brake lever is not released, the brake linings drag continuously. The rear brake may fail due to overheating. Take your foot off the foot brake lever when you are not braking.

**Warning****Danger of accidents** Unstable riding behavior.

- Do not exceed the maximum permissible weight and axle loads.

**Warning****Risk of misappropriation** Usage by unauthorized persons.

- Never leave the vehicle while the engine is running. Secure the vehicle against use by unauthorized persons.

**Info**

When using your motorcycle, remember that others may feel disturbed by excessive noise.

- Make sure that the pre-delivery inspection work has been carried out by an authorized KTM workshop.
 - ✓ You receive a delivery certificate and the Service and Warranty Booklet at vehicle handover.
- Before your first trip, read the entire operating instructions carefully.
- Get to know the controls.
- Adjust the basic position of the clutch lever. (☞ p. 58)
- Adjust the free travel of the handbrake lever. (☞ p. 61)
- Adjust the basic position of the foot brake lever. ☞ (☞ p. 65)
- Adjust the basic position of the shift lever. ☞ (☞ p. 86)
- Get used to handling the motorcycle on a suitable piece of land before making a longer trip.

**Info**

When offroad, being accompanied by another person on another vehicle so that you can help each other is recommended.

- Try also to ride as slowly as possible and in a standing position to get a better feeling for the vehicle.
- Do not make any offroad trips that over-stress your ability and experience.
- Hold the handlebar firmly with both hands and keep your feet on the footrests when riding.
- If you carry any baggage, make sure it is fixed firmly as close as possible to the center of the vehicle and ensure even weight distribution between the front and rear wheels.



Info

Motorcycles react sensitively to any changes of weight distribution.

- Do not exceed the overall maximum permitted weight and the axle loads.

Guideline

Maximum permissible overall weight	280 kg (617 lb.)
Maximum permissible front axle load	135 kg (298 lb.)
Maximum permissible rear axle load	175 kg (386 lb.)

- Run the engine in. (🔍 p. 23)

8.2 Running in the engine

- During the running-in phase, do not exceed the specified engine speed and engine performance.

Guideline

Maximum engine speed	
During the first operating hour	7,000 rpm
Maximum engine performance	
During the first 3 operating hours	≤ 75 %

- Avoid fully opening the throttle!

9.1 Checks and maintenance work when preparing for use



Info

Before riding the vehicle, always check its condition and operating safety. The vehicle must be in perfect technical condition when used.

- Check the engine oil level. (☛ p. 87)
- Check the electrical system.
- Check the brake fluid level of the front brake. (☛ p. 62)
- Check the rear brake fluid level. (☛ p. 66)
- Check the front brake linings. (☛ p. 63)
- Check the rear brake linings. (☛ p. 67)
- Check that the brake system is functioning properly.
- Check the coolant level. (☛ p. 83)
- Check for chain dirt accumulation. (☛ p. 53)
- Check the chain, rear sprocket, engine sprocket and chain guide. (☛ p. 55)
- Check the chain tension. (☛ p. 53)
- Check the tire condition. (☛ p. 72)
- Check the tire air pressure. (☛ p. 73)
- Check the spoke tension. (☛ p. 73)
- Clean the dust boots of the fork legs. (☛ p. 38)
- Bleed the fork legs. (☛ p. 37)
- Check the air filter.
- Check the settings of all controls and ensure that they can be operated smoothly.
- Check all screws, nuts, and hose clamps regularly for tightness.
- Check the fuel supply.

9.2 Starting



Danger

Danger of poisoning Exhaust gases are toxic and inhaling them may result in unconsciousness and/or death.

- When running the engine, always make sure there is sufficient ventilation, and do not start or run the engine in an enclosed space without an effective exhaust extraction system.

Note

Engine failure High engine speeds in cold engines have a negative effect on the service life of the engine.

- Always warm up the engine at low engine speeds.

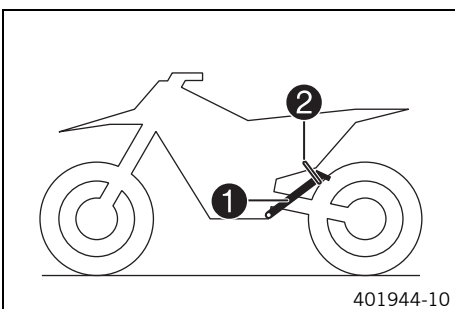

- Take the motorcycle off the side stand **1** and secure the side stand with rubber band **2**.
- Shift gear to neutral.

(Freeride 350 AU)

- Press the emergency OFF switch into the position .

Condition

Ambient temperature: < 20 °C (< 68 °F)

- Pull the idle speed adjusting screw all the way out.

- Press the electric starter button.



Info

Press the electric starter button for at most 5 seconds. Wait for a least 5 seconds before trying again.

FI warning lamp lights up briefly as a functional control when starting.

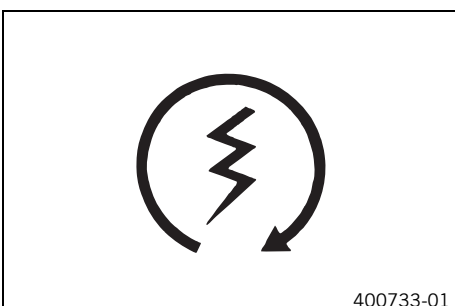

9.3 Starting off



Info

When you are riding, the side stand must be folded up and secured with the rubber band.

- Pull the clutch lever, engage 1st gear, release the clutch lever slowly and simultaneously open the throttle carefully.

9.4 Shifting, riding



Warning

Danger of accidents If you change down at high engine speed, the rear wheel can lock up.

- Do not change into a low gear at high engine speed. The engine races and the rear wheel can lock up.



Info

If you hear unusual noises while riding, stop immediately, switch off the engine and contact an authorized KTM workshop. First gear is used for starting off or for steep inclines.

- When conditions allow (incline, road situation, etc.), you can shift into a higher gear. To do so, release the throttle while simultaneously pulling the clutch lever, shift into the next gear, release the clutch, and open the throttle.
- After reaching maximum speed by fully opening the throttle grip, turn the throttle back so it is $\frac{3}{4}$ open. This will barely reduce the speed but fuel consumption will be considerably lower.
- Always open the throttle only as much as the engine can handle – abrupt throttle opening increases fuel consumption.
- To shift down, brake and close the throttle at the same time.
- Pull the clutch lever and shift into a lower gear, release the clutch lever slowly, and open the throttle or shift again.
- Switch off the engine if you expect to be standing for a long time.

Guideline

≥ 2 min

- Avoid frequent and longer slipping of the clutch. This heats the engine oil, the engine, and the cooling system.
- Ride with a lower engine speed instead of with a high engine speed and a slipping clutch.

9.5 Applying the brakes



Warning

Danger of accidents If you brake too hard, the wheels can lock.

- Adapt your braking to the traffic situation and the road conditions.



Warning

Danger of accidents Reduced braking efficiency caused by spongy pressure point of front or rear brake.

- Check the brake system and do not continue riding. (Your authorized KTM workshop will be glad to help.)



Warning

Danger of accidents Reduced braking efficiency due to a wet or dirty brake system.

- Clean or dry a dirty or wet brake system by riding and braking gently.

- On sandy, wet or slippery surfaces, use the rear brake.
- Braking should always be completed before you go into a bend. Change down to a lower gear appropriate to your road speed.
- On long downhill stretches, use the braking effect of the engine. Change down one or two gears, but do not overstress the engine. In this way, you have to apply the brakes far less frequently and the brake system does not overheat.

9.6 Stopping, parking



Warning

Risk of misappropriation Usage by unauthorized persons.

- Never leave the vehicle while the engine is running. Secure the vehicle against use by unauthorized persons.



Warning

Danger of burns Some vehicle components become very hot when the vehicle is operated.

- Do not touch hot components such as exhaust system, radiator, engine, shock absorber, and the brake system. Allow these components to cool down before starting work on them.

Note

Danger of damage The parked vehicle may roll away or fall over.

- Always place the vehicle on a firm and even surface.

Note

Fire hazard Some vehicle components become very hot when the vehicle is operated.

- Do not park the vehicle near flammable or explosive substances. Do not place objects on the vehicle while it is still warm from being run. Always let the vehicle cool first.

Note

Material damage Damage to or destruction of components due to excessive load.

- The side stand is only designed for the weight of the motorcycle. Do not sit on the motorcycle when it is resting on the side stand. The side stand or the frame may become damaged and the motorcycle may fall over.

-
- Brake the motorcycle.
 - Shift gear to neutral.
 - Press and hold the kill switch ☒ while the engine is idling until the engine stops.
 - Park the motorcycle on firm ground.

9.7 Transport

Note

Danger of damage The parked vehicle may roll away or fall over.

- Always place the vehicle on a firm and even surface.

Note

Fire hazard Some vehicle components become very hot when the vehicle is operated.

- Do not park the vehicle near flammable or explosive substances. Do not place objects on the vehicle while it is still warm from being run. Always let the vehicle cool first.

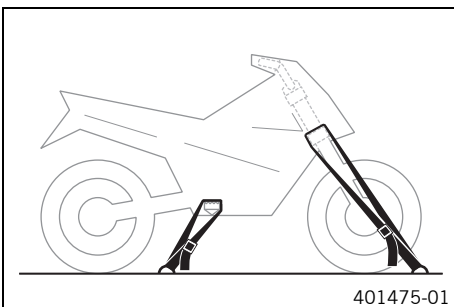

- Switch off the engine.
- Use tension belts or other suitable devices to secure the motorcycle against accidents or falling over.

9.8 Refueling

- Danger**
Fire hazard Fuel is highly flammable.
- Never refuel the vehicle near open flames or burning cigarettes, and always switch off the engine first. Be careful that no fuel is spilt, especially on hot vehicle components. Clean up spilt fuel immediately.
 - The fuel in the fuel tank expands when warm and may emerge if overfilled. Follow the instructions on refueling.

- Warning**
Danger of poisoning Fuel is poisonous and a health hazard.
- Fuel must not come into contact with the skin, eyes, or clothing. Do not breathe in the fuel vapors. If contact occurs with the eyes, rinse with water immediately and contact a physician. Immediately clean contaminated areas on the skin with soap and water. If fuel is swallowed, contact a physician immediately. Change clothing that is contaminated with fuel.

- Note**
Material damage Premature clogging of the fuel filter.
- In some countries and regions, the available fuel quality and cleanliness may not be sufficient. This will result in problems with the fuel system. (Your authorized KTM workshop will be glad to help.)
 - Only refuel with clean fuel that meets the specified standards.

- Warning**
Environmental hazard Improper handling of fuel is a danger to the environment.
- Do not allow fuel to get into the ground water, the ground, or the sewage system.

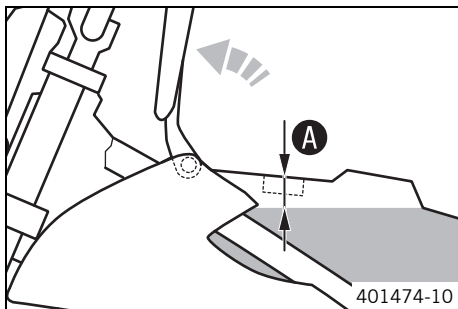

- Preparatory work**
- Switch off the engine.
 - Fold the seat up. (☛ p. 45)
 - Open the filler cap. (☛ p. 14)

- Main work**
- Fill the fuel tank with fuel up to measurement **A**.

Guideline

Measurement of A	30 mm (1.18 in)	
Total fuel tank capacity, approx.	5.5 l (1.45 US gal)	Super unleaded (ROZ 95/RON 95/PON 91) (☛ p. 104)

- Finishing work**
- Close the filler cap. (☛ p. 14)
 - Lock the seat. (☛ p. 45)

10.1 Service schedule

	Every 80 operating hours	Every 20 operating hours	Once after 1 operating hour
Read out the fault memory using the KTM diagnostics tool. 🛠️	○	●	●
Check that the electrical equipment is functioning properly.	○	●	●
Check and charge the battery. 🛠️		●	●
Change the engine oil and oil filter, clean the oil screen. 🛠️ (📖 p. 88)	○	●	●
Check the front brake linings. (📖 p. 63)		●	●
Check the rear brake linings. (📖 p. 67)		●	●
Check the brake discs. (📖 p. 61)		●	●
Check the brake lines for damage and leakage.		●	●
Check the rear brake fluid level. (📖 p. 66)		●	●
Check the free travel of the foot brake lever. (📖 p. 65)		●	●
Check the frame and swingarm. 🛠️		●	●
Check the swingarm bearing. 🛠️			●
Check the heim joints at the top and bottom of the shock absorber. 🛠️		●	●
Check the tire condition. (📖 p. 72)	○	●	●
Check the tire air pressure. (📖 p. 73)	○	●	●
Check the wheel bearing for play. 🛠️		●	●
Check the wheel hubs. 🛠️		●	●
Check the rim run-out. 🛠️	○	●	●
Check the spoke tension. (📖 p. 73)	○	●	●
Check the chain, rear sprocket, engine sprocket and chain guide. (📖 p. 55)		●	●
Check the chain tension. (📖 p. 53)	○	●	●
Grease all moving parts (e.g., side stand, hand lever, chain, ...) and check for smooth operation. 🛠️		●	●
Check the fluid level of the hydraulic clutch. (📖 p. 58)		●	●
Check the brake fluid level of the front brake. (📖 p. 62)		●	●
Check the free travel of the hand brake lever. (📖 p. 61)		●	●
Check the steering head bearing play. (📖 p. 42)	○	●	●
Check the valve clearance. 🛠️	○		●
Check the clutch. 🛠️			●
Change the shaft seal rings of the water pump. 🛠️			●
Change the fuel screen. 🛠️ (📖 p. 87)	○	●	●
Check the fuel pressure. 🛠️		●	●
Check all hoses (e.g. fuel, cooling, bleeder, drainage, etc.) and sleeves for cracking, leaks, and incorrect routing. 🛠️	○	●	●
Check the antifreeze and coolant level. (📖 p. 82)	○	●	●
Check the cables for damage and routing without sharp bends. 🛠️		●	●
Check that the cables are undamaged, routed without sharp bends and set correctly.	○	●	●
Clean the air filter and air filter box. 🛠️		●	●
Change the glass fiber yarn filling of the main silencer. 🛠️ (📖 p. 50)			●
Check the screws and nuts for tightness. 🛠️	○	●	●
Check the headlight setting. (📖 p. 80)	○	●	●
Check idle. 🛠️	○	●	●
Check that the radiator fan is functioning properly. 🛠️	○	●	●
Final check: Check the vehicle for roadworthiness and take a test ride.	○	●	●
Read out the fault memory using the KTM diagnostics tool after a test ride. 🛠️	○	●	●
Make the service entry in the KTM Dealer.net and in the Service and Warranty Booklet. 🛠️	○	●	●

○ One-time interval

● Periodic interval

10.2 Service work (as additional order)

	Once after 20 operating hours	Every 60 operating hours	Every 80 operating hours	Every 160 operating hours	Annually
Change the front brake fluid. 🛠️					•
Change the rear brake fluid. 🛠️					•
Change the foot brake cylinder seals. 🛠️		•			
Change the hydraulic clutch fluid. 🛠️ (🔧 p. 59)					•
Grease the steering head bearing. 🛠️ (🔧 p. 43)					•
Perform a fork service. 🛠️	○		•	•	
Service the shock absorber. 🛠️			•	•	
Change the spark plug and spark plug connector. 🛠️					•
Change the piston. 🛠️					•
Check/measure the cylinder. 🛠️					•
Check the cylinder head. 🛠️					•
Change the valves, valve springs and valve spring seats. 🛠️					•
Check the camshaft and cam lever. 🛠️					•
Change the connecting rod, conrod bearing and crank pin. 🛠️					•
Check the transmission and shift mechanism. 🛠️					•
Check the oil pressure regulator valve. 🛠️					•
Change the suction pump. 🛠️					•
Check the pressure pump and lubrication system. 🛠️					•
Replace the timing chain. 🛠️					•
Check the timing assembly. 🛠️					•
Change all engine bearings. 🛠️					•

- One-time interval
- Periodic interval

11.1 Checking the basic chassis setting with the rider's weight

i Info
When adjusting the basic chassis setting, first adjust the shock absorber and then the fork.

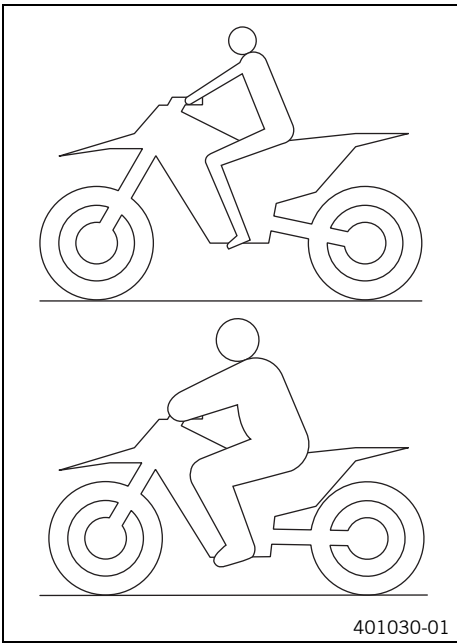

- For optimal motorcycle riding characteristics and to avoid damage to forks, shock absorbers, swingarm and frame, the basic settings of the suspension components must match the rider's weight.
- As delivered, KTM offroad motorcycles are adjusted for an average rider's weight (with full protective clothing).

Guideline

Standard rider weight	75... 85 kg (165... 187 lb.)
-----------------------	------------------------------

- If the rider's weight is above or below this range, the basic setting of the suspension components must be adjusted accordingly.
- Small weight differences can be compensated by adjusting the spring preload, but in the case of large weight differences, the springs must be replaced.

11.2 Compression damping of the shock absorber

The compression damping of the shock absorber is divided into two ranges: high-speed and low-speed. High-speed and low-speed refer to the compression speed of the rear wheel suspension and not to the vehicle speed. The high-speed setting, for example, has an effect on the landing after a jump: the rear wheel suspension compresses more quickly. The low-speed setting, for example, has an effect when riding over long ground swells: the rear wheel suspension compresses more slowly. These two ranges can be adjusted separately, although the transition between high-speed and low-speed is gradual. Thus, changes in the high-speed range affect the compression damping in the low-speed range and vice versa.

11.3 Adjusting the low-speed compression damping of the shock absorber

⚠ Caution
Danger of accidents Disassembly of pressurized parts can lead to injury.

- The shock absorber is filled with high density nitrogen. Adhere to the description provided. (Your authorized KTM workshop will be glad to help.)

i Info
The low-speed setting can be seen during the slow to normal compression of the shock absorber.



- Turn adjusting screw **1** clockwise with a screwdriver up to the last perceptible click.

i Info
Do not loosen nut **2**!

- Turn counterclockwise by the number of clicks corresponding to the shock absorber type.

Guideline

Compression damping, low-speed	
Comfort	20 clicks
Standard	15 clicks
Sport	5 clicks

i Info
Turn clockwise to increase damping; turn counterclockwise to reduce damping.

11.4 Adjusting the high-speed compression damping of the shock absorber

! Caution
Danger of accidents Disassembly of pressurized parts can lead to injury.

- The shock absorber is filled with high density nitrogen. Adhere to the description provided. (Your authorized KTM workshop will be glad to help.)

i Info
The high-speed setting can be seen during the fast compression of the shock absorber.



Preparatory work

- Raise the motorcycle with the lift stand. (☛ p. 37)
- Fold the seat up. (☛ p. 45)
- Remove the shock absorber. ☞ (☛ p. 44)

Main work

- Turn adjusting screw ① all the way clockwise with a socket wrench.

i Info
Do not loosen nut ②!

- Turn counterclockwise by the number of turns corresponding to the shock absorber type.

Guideline

Compression damping, high-speed	
Comfort	2.5 turns
Standard	2 turns
Sport	1 turn

i Info
Turn clockwise to increase damping; turn counterclockwise to reduce damping.

Finishing work

- Install the shock absorber. ☞ (☛ p. 44)
- Lock the seat. (☛ p. 45)
- Remove the motorcycle from the lift stand. (☛ p. 37)

11.5 Adjusting the rebound damping of the shock absorber

! Caution
Danger of accidents Disassembly of pressurized parts can lead to injury.

- The shock absorber is filled with high density nitrogen. Adhere to the description provided. (Your authorized KTM workshop will be glad to help.)

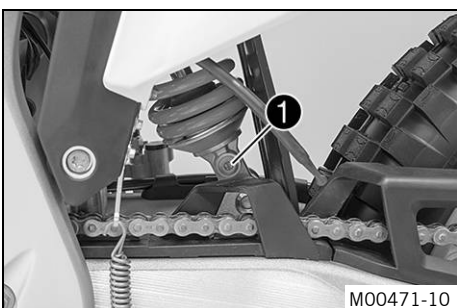

- Turn adjusting screw ① clockwise up to the last perceptible click.
- Turn counterclockwise by the number of clicks corresponding to the shock absorber type.

Guideline

Rebound damping	
Comfort	20 clicks
Standard	15 clicks
Sport	10 clicks



Info

Turn clockwise to increase damping; turn counterclockwise to reduce damping.

11.6 Measuring rear wheel sag unloaded

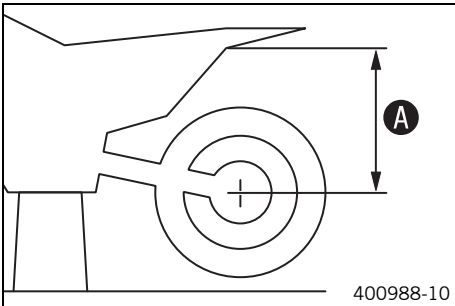

Preparatory work

- Raise the motorcycle with the lift stand. (🔧 p. 37)

Main work

- Measure the distance – as vertical as possible – between the rear axle and a fixed point, for example, a mark on the rear fairing.
- Note down the value as dimension **A**.

Finishing work

- Remove the motorcycle from the lift stand. (🔧 p. 37)

11.7 Checking the static sag of the shock absorber

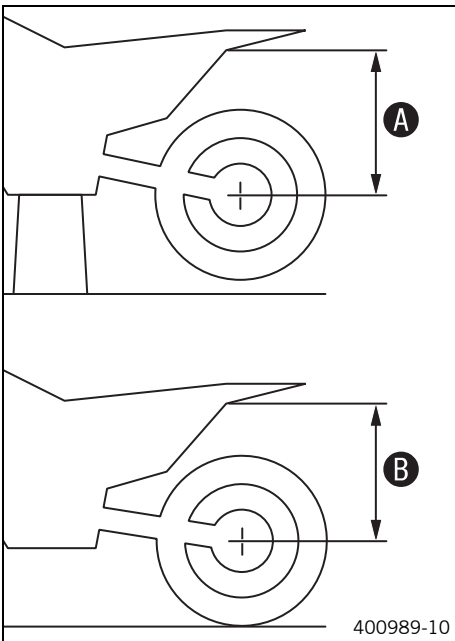

- Measure distance **A** of rear wheel unloaded. (🔧 p. 32)
- Hold the motorcycle upright with the aid of an assistant.
- Measure the distance between the rear axle and the fixed point again.
- Note down the value as dimension **B**.



Info

The static sag is the difference between measurements **A** and **B**.

- Check the static sag.

Static sag	15 mm (0.59 in)
------------	-----------------

- » If the static sag is less or more than the specified value:
 - Adjust the spring preload of the shock absorber. 🛠️ (🔧 p. 33)

11.8 Checking the riding sag of the shock absorber

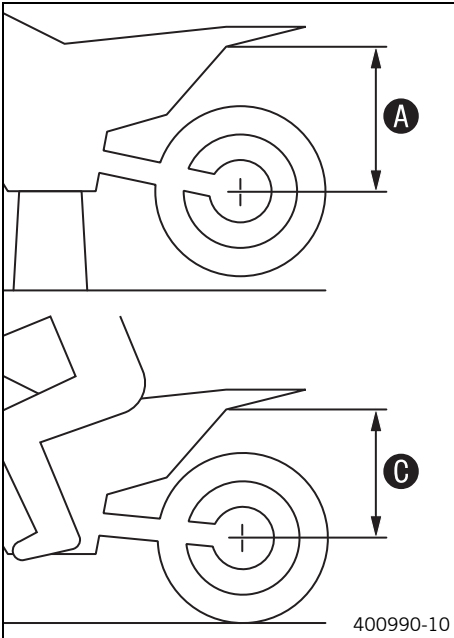

- Measure distance **A** of rear wheel unloaded. (☞ p. 32)
- With another person holding the motorcycle, the rider, wearing full protective clothing, sits on the seat in a normal sitting position (feet on footrests) and bounces up and down a few times.
 - ✓ The rear wheel suspension levels out.
- Another person now measures the distance between the rear axle and a fixed point.
- Note down the value as dimension **C**.

i Info

The riding sag is the difference between measurements **A** and **C**.

- Check the riding sag.

Riding sag	80 mm (3.15 in)
------------	-----------------

- » If the riding sag differs from the specified measurement:
 - Adjust the riding sag. ☞ (☞ p. 34)

11.9 Adjusting the spring preload of the shock absorber ☞

! Caution

Danger of accidents Disassembly of pressurized parts can lead to injury.

- The shock absorber is filled with high density nitrogen. Adhere to the description provided. (Your authorized KTM workshop will be glad to help.)

i Info

Before changing the spring preload, make a note of the present setting, e.g., by measuring the length of the spring.

Preparatory work

- Raise the motorcycle with the lift stand. (☞ p. 37)
- Fold the seat up. (☞ p. 45)
- Remove the shock absorber. ☞ (☞ p. 44)
- After removing the shock absorber, clean it thoroughly.

Main work

- Loosen screw **1**.
- Turn adjusting ring **2** until the spring is no longer under tension.

Hook wrench (T106S)

- Measure the overall spring length while the spring is not under tension.
- Tighten the spring by turning adjusting ring **2** to measurement **A**.

Guideline

Spring preload	
Comfort	12 mm (0.47 in)
Standard	12 mm (0.47 in)
Sport	12 mm (0.47 in)

i Info

Depending on the static sag and/or the riding sag, it may be necessary to increase or decrease the spring preload.

- Tighten screw **1**.

Guideline

Screw, shock absorber adjusting ring	M5	5 Nm (3.7 lbf ft)
--------------------------------------	----	-------------------

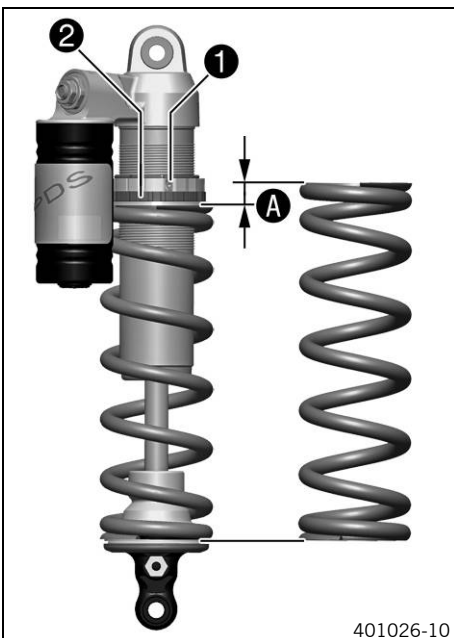

Finishing work

- Install the shock absorber. ↘ (☞ p. 44)
- Lock the seat. (☞ p. 45)
- Remove the motorcycle from the lift stand. (☞ p. 37)

11.10 Adjusting the riding sag ↘

Preparatory work

- Raise the motorcycle with the lift stand. (☞ p. 37)
- Fold the seat up. (☞ p. 45)
- Remove the shock absorber. ↘ (☞ p. 44)
- After removing the shock absorber, clean it thoroughly.

Main work

- Choose and mount a suitable spring.

Guideline

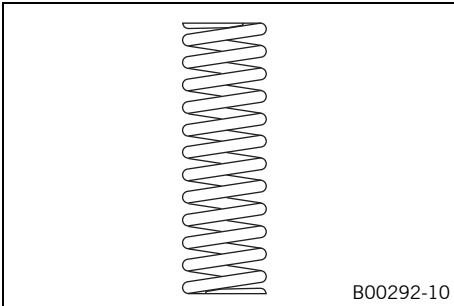

Spring designation	
Weight of rider: 65... 75 kg (143... 165 lb.)	55/63/71-215
Weight of rider: 75... 85 kg (165... 187 lb.)	58/66/74-215
Weight of rider: 85... 95 kg (187... 209 lb.)	66-215



Info

The spring rate is shown on the outside of the spring. Smaller weight differences can be compensated by changing the spring preload.

Finishing work

- Install the shock absorber. ↘ (☞ p. 44)
- Lock the seat. (☞ p. 45)
- Remove the motorcycle from the lift stand. (☞ p. 37)
- Check the static sag of the shock absorber. (☞ p. 32)
- Check the riding sag of the shock absorber. (☞ p. 33)
- Adjust the rebound damping of the shock absorber. (☞ p. 31)

11.11 Checking the basic setting of the fork



Info

For various reasons, no exact riding sag can be determined for the forks.

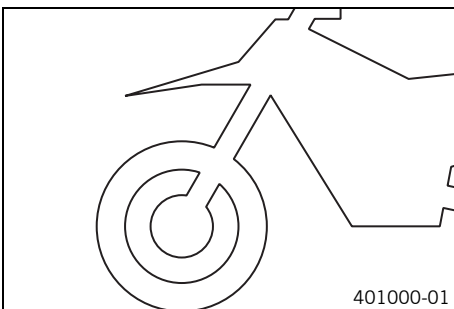

- As with the shock absorber, smaller differences in the rider's weight can be compensated by the spring preload.
- However, if the fork is often overloaded (hard end stop on compression), harder springs must be fit to avoid damage to the fork and frame.

11.12 Adjusting the compression damping of the fork

i Info
The hydraulic compression damping determines the fork suspension behavior.

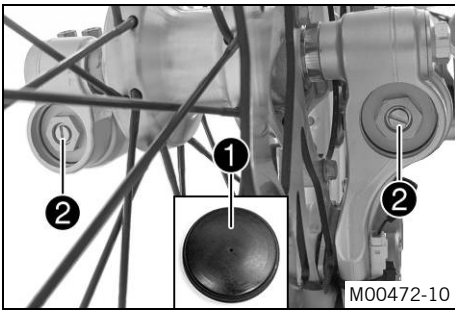

- Remove protection caps ❶.
- Turn adjusting screws ❷ clockwise all the way.

i Info
Adjusting screws ❷ are located at the bottom end of the fork legs. Make the same adjustment on both fork legs.

- Turn back counterclockwise by the number of clicks corresponding to the fork type.
- Guideline

Compression damping	
Comfort	25 clicks
Standard	20 clicks
Sport	15 clicks

i Info
Turn clockwise to increase damping; turn counterclockwise to reduce damping.

- Mount protection covers ❶.

11.13 Adjusting the rebound damping of the fork

i Info
The hydraulic rebound damping determines the fork suspension behavior.

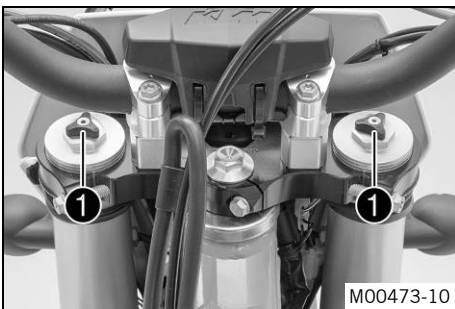

- Turn adjusting screws ❶ clockwise all the way.

i Info
Adjusting screws ❶ are located at the top end of the fork legs. Make the same adjustment on both fork legs.

- Turn back counterclockwise by the number of clicks corresponding to the fork type.
- Guideline

Rebound damping	
Comfort	25 clicks
Standard	20 clicks
Sport	15 clicks

i Info
Turn clockwise to increase damping; turn counterclockwise to reduce damping.

11.14 Handlebar position

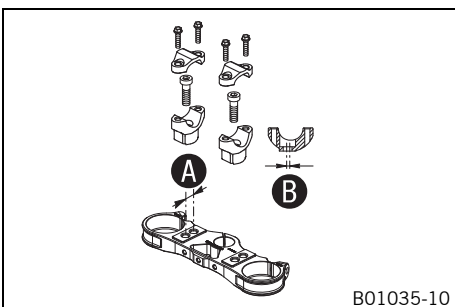

On the upper triple clamp, there are two holes at a distance of **A** to each other.

Hole distance A	15 mm (0.59 in)
------------------------	-----------------

The holes on the handlebar supports are placed at a distance of **B** from the center.

Hole distance B	3.5 mm (0.138 in)
------------------------	-------------------

The handlebar supports can be mounted in four different positions.

11.15 Adjusting the handlebar position ↩

Warning
Danger of accidents Handlebar breakage.

- If the handlebar is bent or straightened it will cause material fatigue, and the handlebar can break. Always replace handlebar.

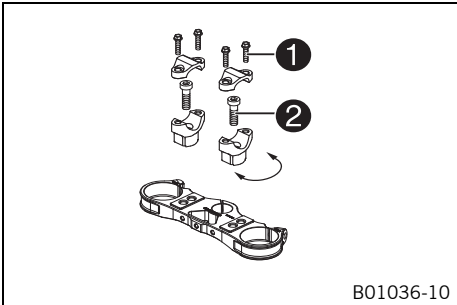

- Remove screws ❶. Remove the handlebar clamps. Take off the handlebar and lay it to one side.

i Info
 Cover the components to protect them against damage.
 Do not bend the cables and lines.

- Remove screws ❷. Take off the handlebar supports.
- Move the handlebar supports into the desired position. Mount and tighten screws ❷.

Guideline

Screw, handlebar support	M10	40 Nm (29.5 lbf ft)	Loctite® 243™
--------------------------	-----	------------------------	----------------------

i Info
 Position the left and right handlebar supports evenly.

- Position the handlebar.

i Info
 Make sure cables and wiring are positioned correctly.

- Position the handlebar clamps. Mount screws ❶ and tighten evenly.

Guideline

Screw, handlebar clamp	M8	20 Nm (14.8 lbf ft)
------------------------	----	------------------------

i Info
 Make sure the gap width is even.

12.1 Raising the motorcycle with the lift stand

Note

Danger of damage The parked vehicle may roll away or fall over.

- Always place the vehicle on a firm and even surface.

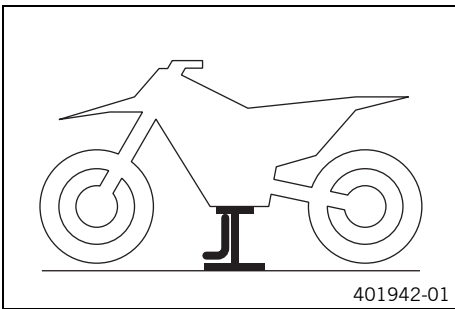

- Raise the motorcycle at the frame underneath the engine.

Lift stand (54829055000)

- ✓ Neither wheel is in contact with the ground.
- Secure the motorcycle against falling over.

12.2 Removing the motorcycle from the lift stand

Note

Danger of damage The parked vehicle may roll away or fall over.

- Always place the vehicle on a firm and even surface.

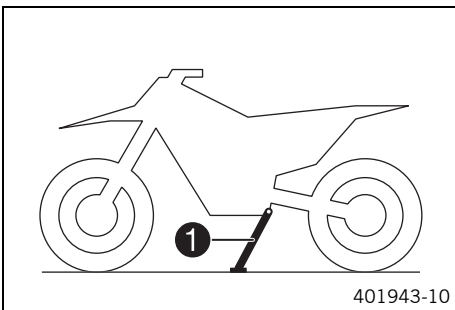

- Remove the motorcycle from the lift stand.
- Remove the lift stand.
- To park the motorcycle, fold side stand ❶ down to the ground with your foot and rest the motorcycle on it.

i Info

While riding, the side stand must be folded up and secured with the rubber band.

12.3 Bleeding the fork legs



Preparatory work

- Raise the motorcycle with the lift stand. (☛ p. 37)

Main work

- Release bleeder screws ❶.
- ✓ Any excess pressure escapes from the interior of the fork.
- Tighten the bleeder screws.

Finishing work

- Remove the motorcycle from the lift stand. (☛ p. 37)

12.4 Cleaning the dust boots of the fork legs



Preparatory work

- Raise the motorcycle with the lift stand. (☛ p. 37)
- Remove the fork protector. (☛ p. 39)

Main work

- Push dust boots ① of both fork legs downward.



Info

The dust boots remove dust and coarse dirt particles from the inside fork tubes. Over time, dirt can penetrate behind the dust boots. If this dirt is not removed, the shaft seal rings behind can start to leak.



Warning

Danger of accidents Reduced braking efficiency due to oil or grease on the brake discs.

- Always keep the brake discs free of oil and grease, and clean them with brake cleaner when necessary.

- Clean and oil the dust boots and inner fork tube of both fork legs.

Universal oil spray (☛ p. 106)

- Press the dust boots back into their normal position.
- Remove excess oil.

Finishing work

- Install the fork protector. (☛ p. 40)
- Remove the motorcycle from the lift stand. (☛ p. 37)

12.5 Removing the fork legs 🛠️

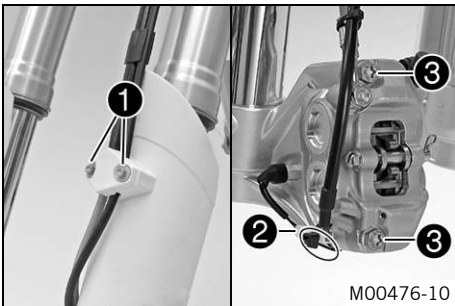

Preparatory work

- Remove the headlight mask with the headlight. (☛ p. 78)
- Raise the motorcycle with the lift stand. (☛ p. 37)
- Remove the front wheel. 🛠️ (☛ p. 70)

Main work

- Remove screws ① and take off the clamp.
- Remove the cable tie(s) and detach plug-in connector ②.
- Remove screws ③ and the spacers and take off the brake caliper.
- Allow the brake caliper and brake line to hang tension-free to the side.

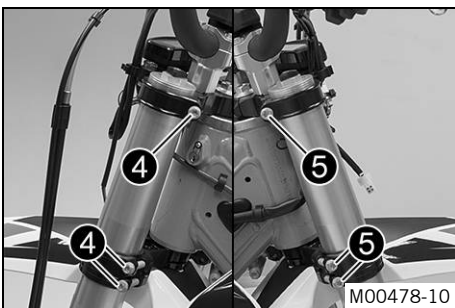

- Release screws ④. Take out the left fork leg.
- Release screws ⑤. Take out the right fork leg.

12.6 Installing the fork legs



Main work

- Position the fork legs.
- ✓ Bleeder screws **1** face forward.



Info

Grooves are milled into the side of the upper end of the fork legs. The second milled groove (from the top) must be flush with the top edge of the upper triple clamp.

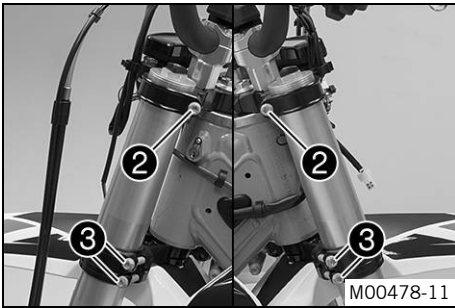

- Tighten screws **2**.

Guideline

Screw, top triple clamp	M8	22 Nm (16.2 lbf ft)
-------------------------	----	------------------------

- Tighten screws **3**.

Guideline

Screw, bottom triple clamp	M8	18 Nm (13.3 lbf ft)
----------------------------	----	------------------------

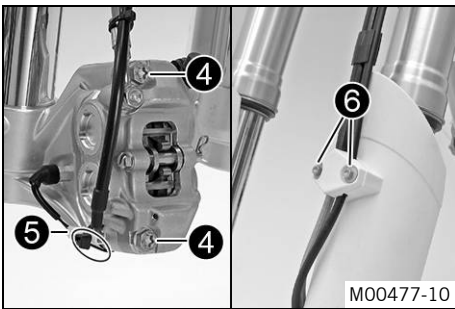

- Position the brake caliper. Mount and tighten screws **4** with the spacers.

Guideline

Screw, front brake caliper	M8	25 Nm (18.4 lbf ft)	Loctite® 243™
----------------------------	----	------------------------	---------------

- Connect the plug-in connector **5** and mount the cable ties.
- Position the brake line, wiring harness, and clamp. Mount and tighten screws **6**.

Finishing work

- Install the front wheel. (☞ p. 70)
- Refit the headlight mask with the headlight. (☞ p. 78)
- Check the headlight setting. (☞ p. 80)

12.7 Removing the fork protector

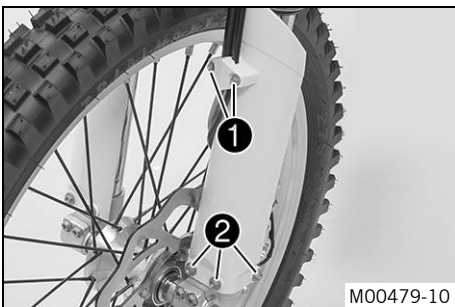

- Remove screws **1**. Take off the clamp.
- Remove screws **2** on the left fork leg. Take off the fork protector.

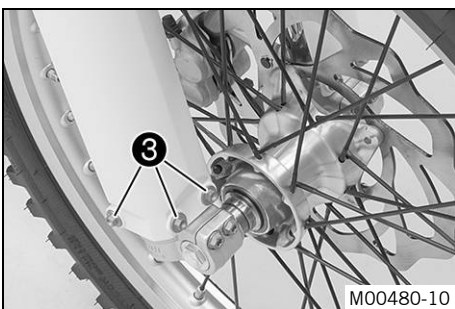

- Remove screws **3** on the right fork leg. Take off the fork protector.

12.8 Installing the fork protector

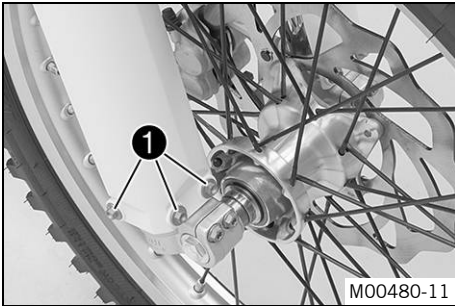

- Position the fork protection on the right fork leg. Mount and tighten screws ❶.

Guideline

Remaining screws, chassis	M6	10 Nm (7.4 lbf ft)
---------------------------	----	--------------------

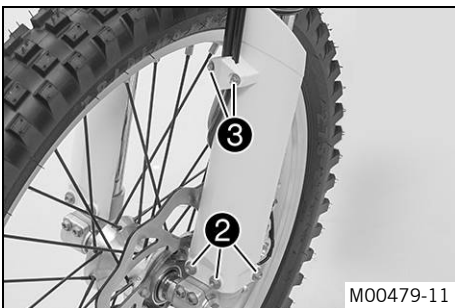

- Position the fork protection on the left fork leg. Mount and tighten screws ❷.

Guideline

Remaining screws, chassis	M6	10 Nm (7.4 lbf ft)
---------------------------	----	--------------------

- Position the brake line, wiring harness, and clamp. Mount and tighten screws ❸.

12.9 Removing the lower triple clamp

Preparatory work

- Remove the headlight mask with the headlight. (☛ p. 78)
- Raise the motorcycle with the lift stand. (☛ p. 37)
- Remove the front wheel. ☛ (☛ p. 70)
- Remove the fork legs. ☛ (☛ p. 38)
- Remove the front fender. (☛ p. 44)

Main work

- Remove the cable holder ❶ in front of the radiator.

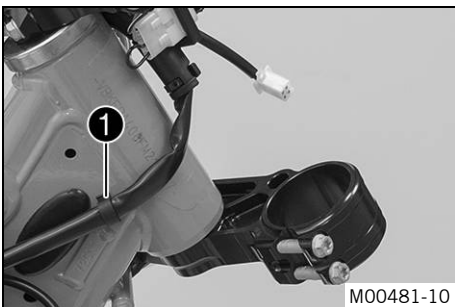

- Remove screw ❷.
- Remove screw ❸, take off the upper triple clamp with the handlebar and set it aside.



Info

Cover the components to protect them against damage.
Do not bend the cables and lines.

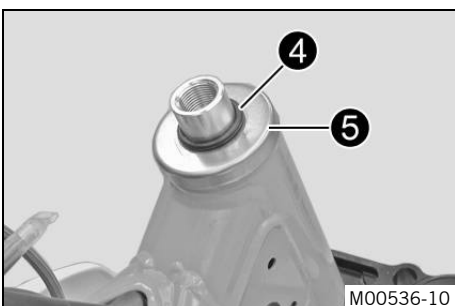
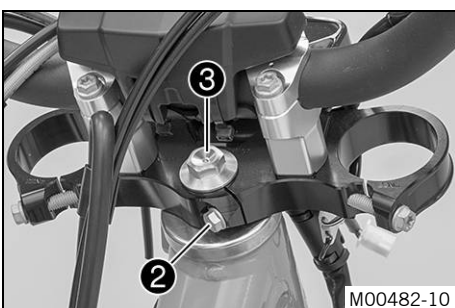

- Remove O-ring ❹. Remove protective ring ❺.
- Take out the lower triple clamp with the steering stem.
- Take out the upper steering head bearing.

12.10 Installing the lower triple clamp

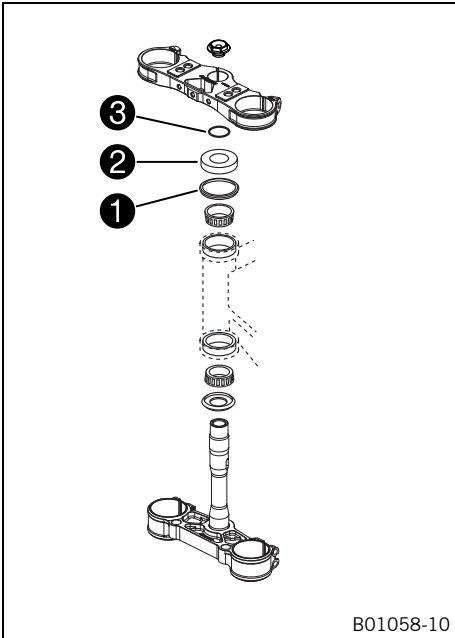

Main work

- Clean the bearing and sealing elements, check for damage, and grease.

High viscosity grease (☛ p. 105)

- Insert the lower triple clamp with the steering stem. Mount the upper steering head bearing.
- Check whether the top steering head seal ① is correctly positioned.
- Slide on protective ring ② and O-ring ③.

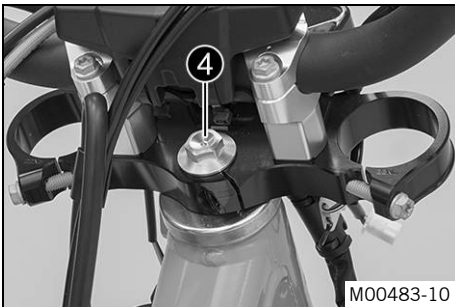

- Position the upper triple clamp with the steering.
- Mount screw ④ but do not tighten yet.
- Position the clutch line and wiring harness.



- Position the fork legs.
- ✓ Bleeder screws ⑤ face forward.

Info

Grooves are milled into the side of the upper end of the fork legs. The second milled groove (from the top) must be flush with the top edge of the upper triple clamp.

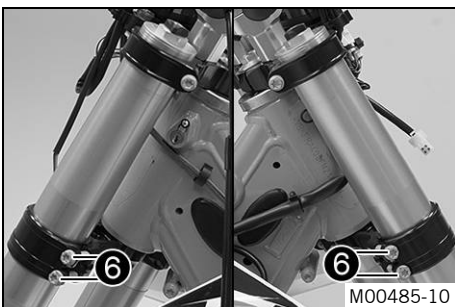

- Tighten screws ⑥.

Guideline

Screw, bottom triple clamp	M8	18 Nm (13.3 lbf ft)
----------------------------	----	------------------------

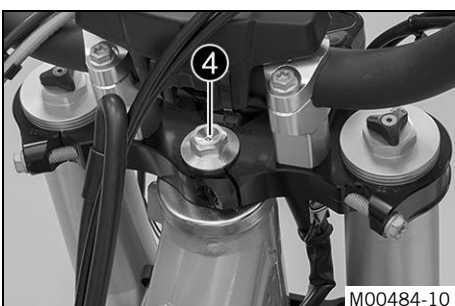

- Tighten screw ④.

Guideline

Screw, top steering head	M20x1.5	12 Nm (8.9 lbf ft)
--------------------------	---------	--------------------

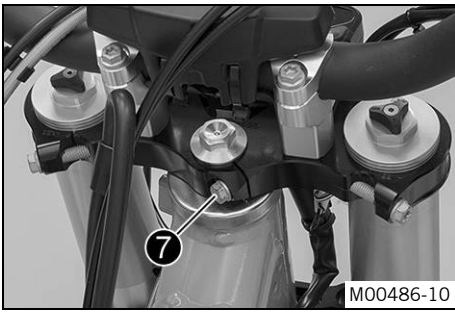

- Mount and tighten screw 7.

Guideline

Screw, top steering stem	M8	17 Nm (12.5 lbf ft)	Loctite® 243™
--------------------------	----	------------------------	---------------

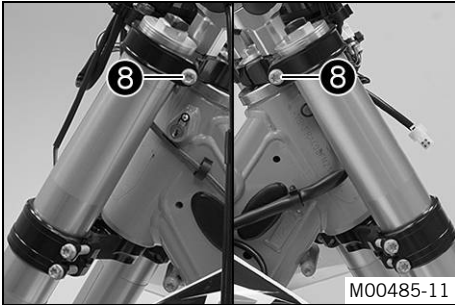

- Tighten screws 8.

Guideline

Screw, top triple clamp	M8	22 Nm (16.2 lbf ft)	
-------------------------	----	------------------------	--



- Secure the cable holder 9.

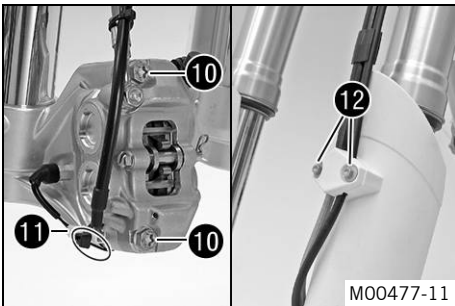

- Position the brake caliper. Mount and tighten screws 10 with the spacers.

Guideline

Screw, front brake caliper	M8	25 Nm (18.4 lbf ft)	Loctite® 243™
----------------------------	----	------------------------	---------------

- Connect the plug-in connector 11 and mount the cable ties.
- Position the brake line, wiring harness, and clamp. Mount and tighten screws 12.

Finishing work

- Install the front fender. (☛ p. 44)
- Install the front wheel. ☛ (☛ p. 70)
- Refit the headlight mask with the headlight. (☛ p. 78)
- Check that the wiring harness, cables, and brake and clutch lines can move freely and are routed correctly.
- Check the steering head bearing play. (☛ p. 42)
- Remove the motorcycle from the lift stand. (☛ p. 37)
- Check the headlight setting. (☛ p. 80)

12.11 Checking the steering head bearing play

Warning
Danger of accidents Unstable vehicle handling from incorrect steering head bearing play.

- Adjust the steering head bearing play without delay. (Your authorized KTM workshop will be glad to help.)

Info
 If the bike is ridden with play in the steering head bearing, the bearing and the bearing seats in the frame can become damaged over time.

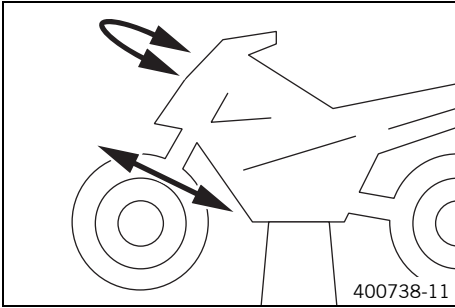

Preparatory work

- Raise the motorcycle with the lift stand. (☛ p. 37)

Main work

- Move the handlebar to the straight-ahead position. Move the fork legs to and fro in the direction of travel.

No play should be noticeable in the steering head bearing.

- » If there is noticeable play present:
 - Adjust the play of the steering head bearing. ☛ (☛ p. 43)

- Move the handlebar to and fro over the entire steering range.

The handlebar must be able to move easily over the entire steering range. No resting locations should be noticeable.

- » If click positions are noticeable:
 - Adjust the play of the steering head bearing. ☛ (☛ p. 43)
 - Check the steering head bearing and replace if required.

Finishing work

- Remove the motorcycle from the lift stand. (☛ p. 37)

12.12 Adjusting the play of the steering head bearing ☛

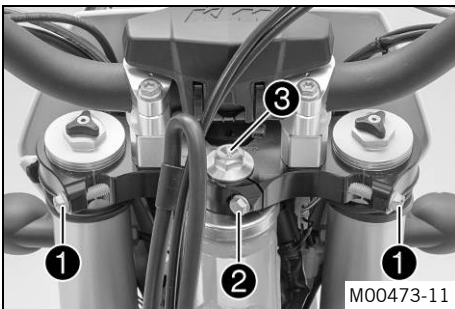

Preparatory work

- Raise the motorcycle with the lift stand. (☛ p. 37)

Main work

- Loosen screws ①. Remove screw ②.
- Loosen and retighten screw ③.

Guideline

Screw, top steering head	M20x1.5	12 Nm (8.9 lbf ft)
--------------------------	---------	--------------------

- Using a plastic hammer, tap lightly on the upper triple clamp to avoid strains.
- Tighten screws ①.

Guideline

Screw, top triple clamp	M8	22 Nm (16.2 lbf ft)
-------------------------	----	---------------------

- Mount and tighten screw ②.

Guideline

Screw, top steering stem	M8	17 Nm (12.5 lbf ft)	Loctite® 243™
--------------------------	----	---------------------	---------------

Finishing work

- Check the steering head bearing play. (☛ p. 42)
- Remove the motorcycle from the lift stand. (☛ p. 37)

12.13 Greasing the steering head bearing ☛

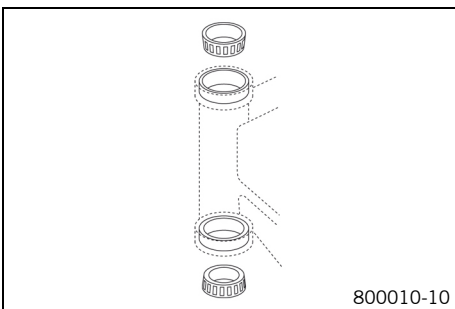

- Remove the lower triple clamp. ☛ (☛ p. 40)
- Install the lower triple clamp. ☛ (☛ p. 41)

12.14 Removing the front fender

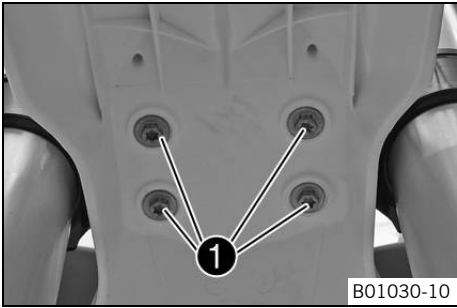

- Remove screws ①. Remove the front fender.

12.15 Installing the front fender

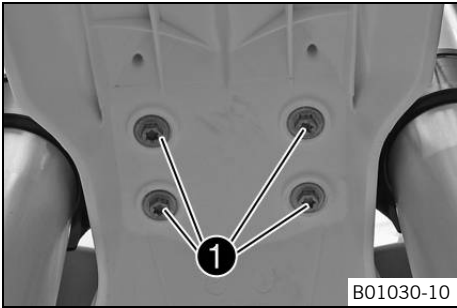

- Position the front fender. Mount and tighten screws ①.

Guideline

Remaining screws, chassis	M6	10 Nm (7.4 lbf ft)
---------------------------	----	--------------------

i Info
Make sure the holding lugs engage in the headlight mask.

12.16 Removing the shock absorber

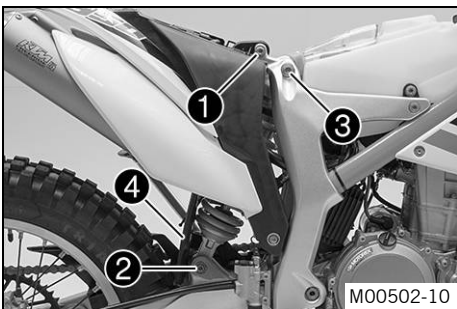

Preparatory work

- Raise the motorcycle with the lift stand. (☛ p. 37)
- Fold the seat up. (☛ p. 45)

Main work

- Remove screw ①.
- Remove screw ② and lower the rear wheel with the swing arm as far as possible without blocking the rear wheel. Fix the rear wheel in this position.
- Remove screw ③.
- Push splash protector ④ to the side and remove the shock absorber.

12.17 Installing the shock absorber

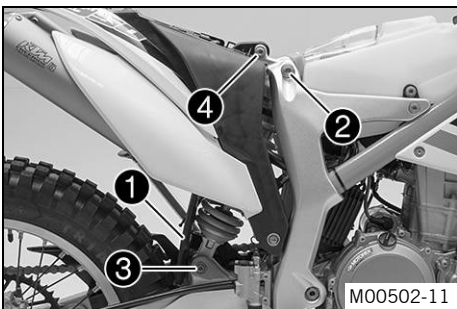

Main work

- Push splash protector ① to the side and position the shock absorber. Mount and tighten screw ②.

Guideline

Screw, top shock absorber	M12	80 Nm (59 lbf ft)	Loctite® 2701™
---------------------------	-----	-------------------	----------------

- Mount and tighten screw ③.

Guideline

Screw, bottom shock absorber	M12	80 Nm (59 lbf ft)	Loctite® 2701™
------------------------------	-----	-------------------	----------------

i Info
The heim joint for the shock absorber at the swingarm is Teflon coated. It must not be greased with grease or with any other lubricants. Lubricants dissolve the Teflon coating, thereby drastically reducing the service life.

- Mount and tighten screw ④.

Guideline

Screw, upper subframe	M10	45 Nm (33.2 lbf ft)	Loctite® 243™
-----------------------	-----	---------------------	---------------

Finishing work

- Lock the seat. (☛ p. 45)
- Remove the motorcycle from the lift stand. (☛ p. 37)

12.18 Folding the seat up

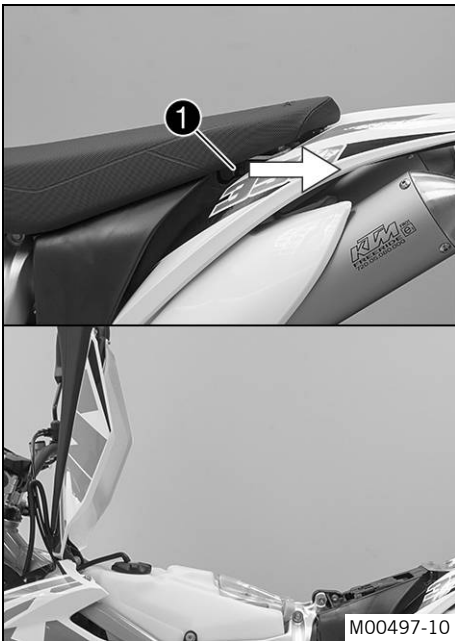

- Press release lever ①.
- Lift the seat and fold it up.

12.19 Locking the seat

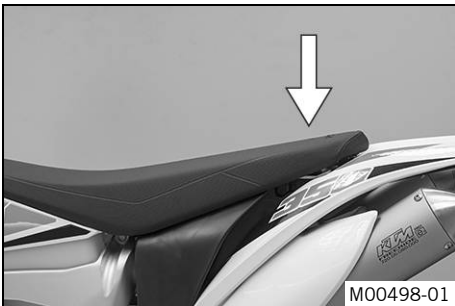

- Fold down the seat and push it down.
- ✓ The seat engages with an audible click.
- Finally, check that the seat is correctly locked.

12.20 Taking off the spoiler

Preparatory work

- Fold the seat up. (☛ p. 45)

Main work

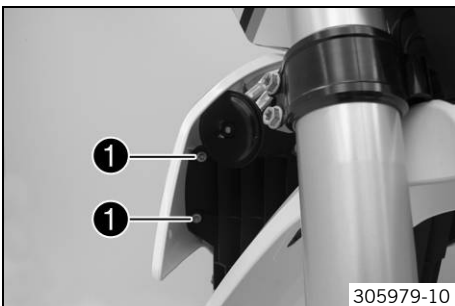

- Remove screws ①.

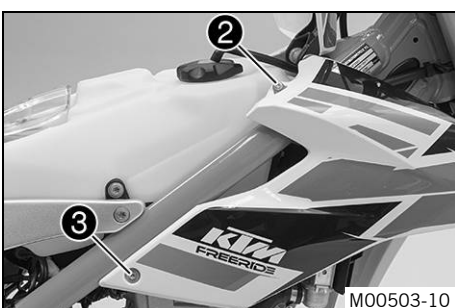

- Remove screw ②.
- Remove screw ③.
- Take off the spoiler.
- Repeat the operation on the opposite side.

12.21 Mounting the spoiler

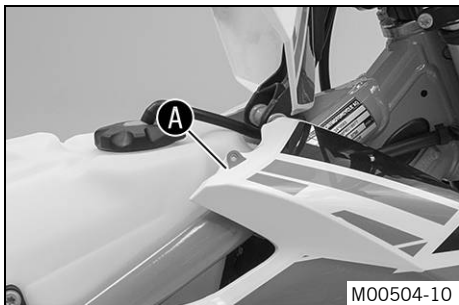

Main work

- Position the spoiler and hook it in at area **A**.



- Mount and tighten screw **1**.

Guideline

Screw for spoiler, top	EJOT PT® K60x20AL	3 Nm (2.2 lbf ft)
------------------------	----------------------	-------------------

- Mount and tighten screw **2**.

Guideline

Screw for spoiler attachment	M6	5 Nm (3.7 lbf ft)
------------------------------	----	-------------------

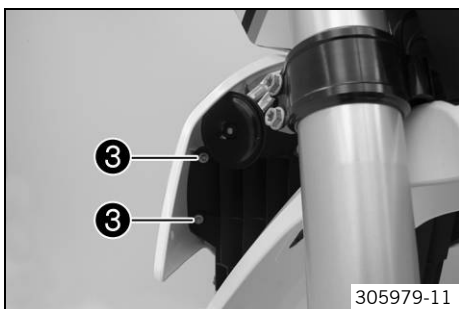

- Mount and tighten screws **3**.

Guideline

Screw for spoiler, front	EJOT PT® K60x30-Z	3 Nm (2.2 lbf ft)
--------------------------	----------------------	-------------------

- Repeat the operation on the opposite side.

Finishing work

- Lock the seat. (☛ p. 45)

12.22 Removing the air filter housing

Note

Engine failure Unfiltered intake air has a negative effect on the service life of the engine.

- Never operate the vehicle without an air filter as dust and dirt will enter the engine and lead to increased wear.

Preparatory work

- Fold the seat up. (☛ p. 45)

Main work

- Pull off air filter housing **1** and pre-filter **2** toward the top.

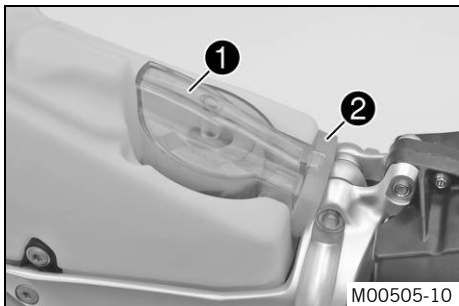

12.23 Installing the air filter housing ↘

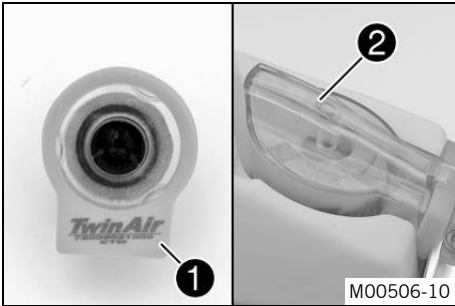

Main work

- Position pre-filter ① on the air filter housing.

Note

Engine failure If the pre-filter is mounted incorrectly or not mounted at all, the air-fuel mixture will change. This has a negative effect on the service life of the engine.

- Make sure the pre-filter is seated correctly.
- Attach air filter housing ② to the inlet flange together with the mounted pre-filter.



Info

If the air filter housing is not mounted correctly, dust and dirt may enter the engine and cause damage.

Finishing work

- Lock the seat. (☞ p. 45)

12.24 Removing the air filter ↘

Note

Engine failure Unfiltered intake air has a negative effect on the service life of the engine.

- Never operate the vehicle without an air filter as dust and dirt will enter the engine and lead to increased wear.



Warning

Environmental hazard Hazardous substances cause environmental damage.

- Oil, grease, filters, fuel, cleaners, brake fluid, etc., should be disposed of as stipulated in applicable regulations.

Preparatory work

- Fold the seat up. (☞ p. 45)
- Remove the air filter housing. ↘ (☞ p. 46)

Main work

- Take off pre-filter ①.
- Open air filter housing ② by turning counterclockwise and take out air filter ④ with air filter support ③.
- Take off air filter ④ from air filter support ③.

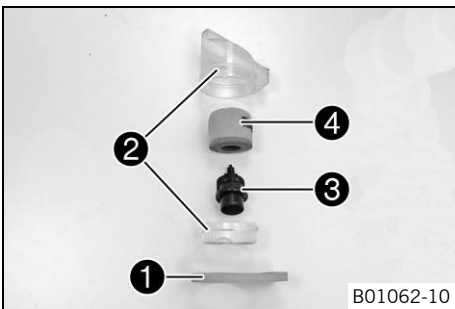

12.25 Installing the air filter ↘

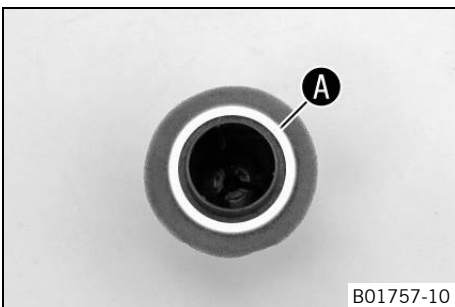

Main work

- Mount the clean air filter onto the air filter support.
- Apply grease to the air filter around area A.

Long-life grease (☞ p. 105)



- Insert both parts together and close air filter housing **1** by turning clockwise.

i Info

If the air filter is not mounted correctly, dust and dirt may enter the engine and cause damage.

Finishing work

- Install the air filter housing. ↘ (☞ p. 47)
- Lock the seat. (☞ p. 45)

12.26 Cleaning the air filter and air filter housing ↘

Warning

Environmental hazard Hazardous substances cause environmental damage.

- Oil, grease, filters, fuel, cleaners, brake fluid, etc., should be disposed of as stipulated in applicable regulations.

i Info

Do not clean the air filter with fuel or petroleum since these substances attack the foam.

Preparatory work

- Fold the seat up. (☞ p. 45)
- Remove the air filter housing. ↘ (☞ p. 46)
- Remove the air filter. ↘ (☞ p. 47)

Main work

- Wash the air filter thoroughly in special cleaning liquid and allow it to dry properly.

Air filter cleaner (☞ p. 105)

i Info

Only press the air filter to dry it, never wring it out.

- Oil the dry air filter with a high quality filter oil.

Oil for foam air filter (☞ p. 105)

- Clean the air filter housing.
- Check the intake flange for damage and ensure it is firmly seated.

Finishing work

- Install the air filter. ↘ (☞ p. 47)
- Install the air filter housing. ↘ (☞ p. 47)
- Lock the seat. (☞ p. 45)



12.27 Removing the main silencer

Warning

Danger of burns The exhaust system gets very hot when the vehicle is driven.

- Allow the exhaust system to cool down. Do not touch hot components.

Remove the right main silencer:

- Take off the spoiler. (☞ p. 45)

i Info

Only remove the right spoiler.

- Disconnect connector **1** of the lambda sensor.

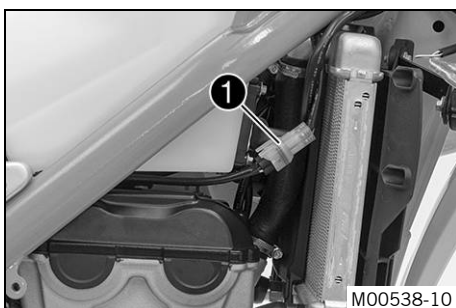

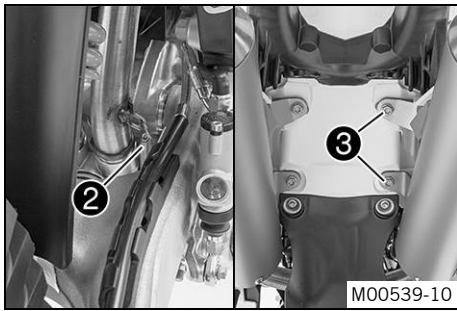

- Disconnect spring ②.
- Remove screws ③ and take off the main silencer.

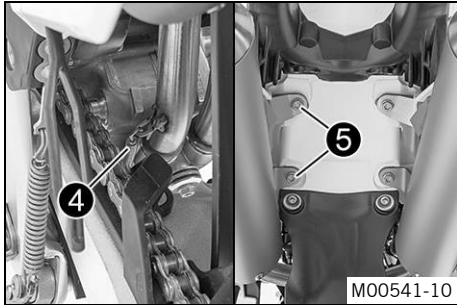

Remove the left main silencer:

- Disconnect spring ④.
- Remove screws ⑤ and take off the main silencer.

12.28 Installing the main silencer

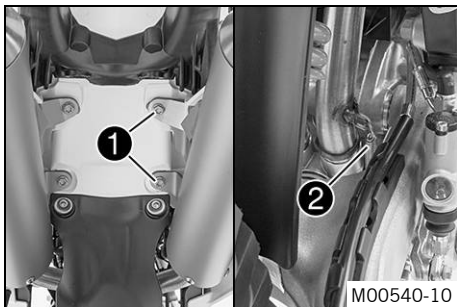

Install the right main silencer:

- Position the main silencer. Mount screws ① but do not tighten yet.
- Attach springs ②.
- Tighten screws ①.

Guideline

Remaining screws, chassis	M8	25 Nm (18.4 lbf ft)
---------------------------	----	------------------------

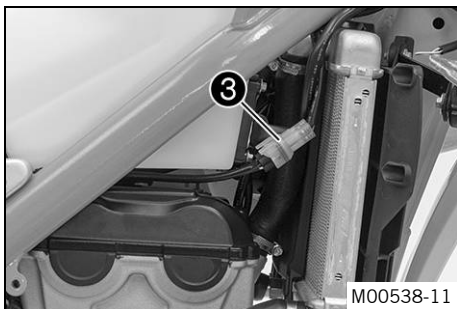

- Plug in connector ③ of the lambda sensor.
- Mount the spoiler. (☞ p. 46)

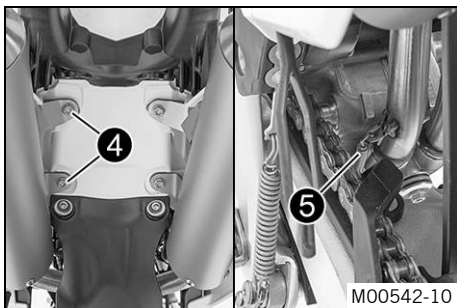

Install the left main silencer:

- Position the main silencer. Mount screws ④ but do not tighten yet.
- Attach springs ⑤.
- Tighten screws ④.

Guideline

Remaining screws, chassis	M8	25 Nm (18.4 lbf ft)
---------------------------	----	------------------------

12.29 Changing the glass fiber yarn filling of the main silencer ↩



Warning

Danger of burns The exhaust system gets very hot when the vehicle is driven.

- Allow the exhaust system to cool down. Do not touch hot components.



Info

Over a period, the fibers of the glass fiber yarn vanish into the air, and the silencer "burns out". Not only is the noise level higher, the performance characteristic changes. The operations are the same for the left and right sides.

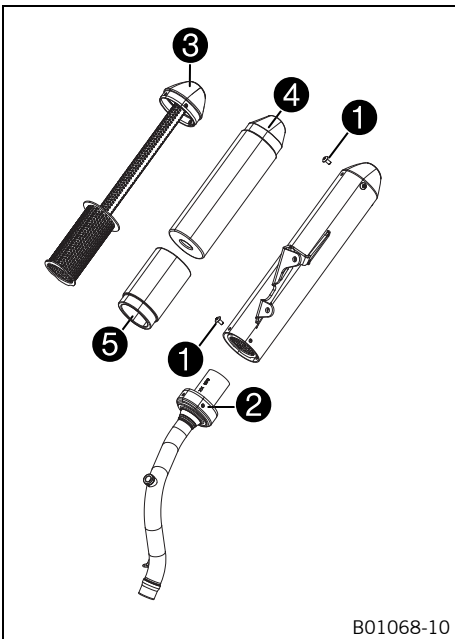

Preparatory work

- Remove the main silencer. (↩ p. 48)

Main work

- Remove screws ①.
- Take off connecting cap ②.
- Remove the silencer cap ③ together with the perforated pipe and glass fiber yarn fillings ④ and ⑤.
- Clean the parts that need to be reinstalled and check for damage.
- Mount the new glass fiber yarn fillings ④ and ⑤ on the perforated pipe.
- Position the silencer cap with the perforated pipe ③ in the outer tube.
- Position the connection cap ②.
- Mount and tighten screws ①.

Guideline

Screws on the main silencer	M5	7 Nm (5.2 lbf ft)
-----------------------------	----	-------------------

Finishing work

- Install the main silencer. (↩ p. 49)

12.30 Removing the fuel tank ↩



Danger

Fire hazard Fuel is highly flammable.

- Never refuel the vehicle near open flames or burning cigarettes, and always switch off the engine first. Be careful that no fuel is spilt, especially on hot vehicle components. Clean up spilt fuel immediately.
- The fuel in the fuel tank expands when warm and may emerge if overfilled. Follow the instructions on refueling.



Warning

Danger of poisoning Fuel is poisonous and a health hazard.

- Fuel must not come into contact with the skin, eyes, or clothing. Do not breathe in the fuel vapors. If contact occurs with the eyes, rinse with water immediately and contact a physician. Immediately clean contaminated areas on the skin with soap and water. If fuel is swallowed, contact a physician immediately. Change clothing that is contaminated with fuel. Store fuel properly in a suitable canister and keep away from children.

Preparatory work

- Fold the seat up. (↩ p. 45)

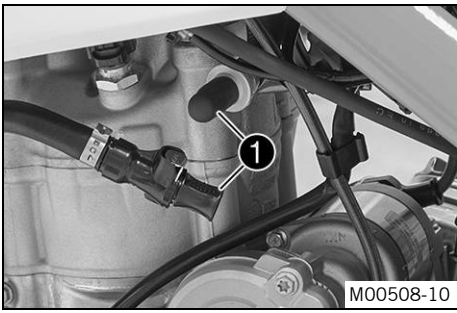

Main work

- Thoroughly clean the plug-in connection of the fuel line using compressed air.



Info

Under no circumstances should dirt enter the fuel line. Dirt in the fuel line clogs the injection valve.

- Disconnect the plug-in connection of the fuel line.
- Mount the wash cap set (1).

Wash cap set (81212016100)

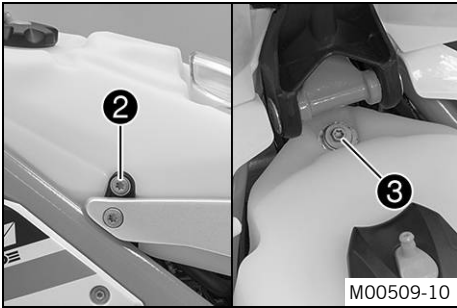

- Remove the tube from the fuel tank breather.
- Remove screws (2) on both sides.
- Remove screw (3).

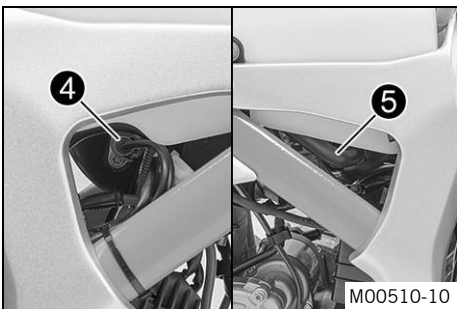

- Unplug connector (4).
- Pull off engine breather hose (5).

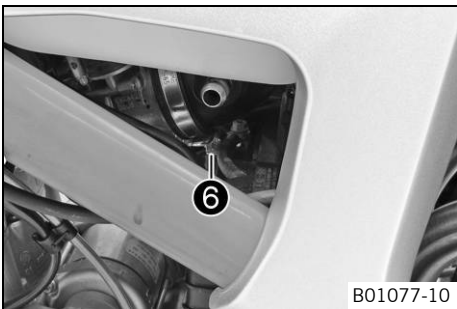

- Release hose clamp (6).
- Detach the intake flange from the throttle valve body.

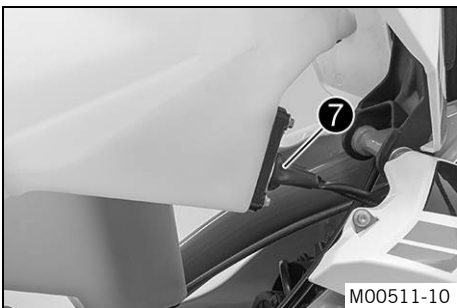

- Pull up the fuel tank slightly and disconnect the connector (7) for the fuel pump.
- Remove the fuel tank from above.

12.31 Installing the fuel tank



Danger

Fire hazard Fuel is highly flammable.

- Never refuel the vehicle near open flames or burning cigarettes, and always switch off the engine first. Be careful that no fuel is spilt, especially on hot vehicle components. Clean up spilt fuel immediately.
- The fuel in the fuel tank expands when warm and may emerge if overfilled. Follow the instructions on refueling.



Warning

Danger of poisoning Fuel is poisonous and a health hazard.

- Fuel must not come into contact with the skin, eyes, or clothing. Do not breathe in the fuel vapors. If contact occurs with the eyes, rinse with water immediately and contact a physician. Immediately clean contaminated areas on the skin with soap and water. If fuel is swallowed, contact a physician immediately. Change clothing that is contaminated with fuel.



Main work

- Check the throttle cable routing. (☛ p. 57)
- Make sure that no cables are trapped or damaged.
- Plug in the connector ① for the fuel pump.

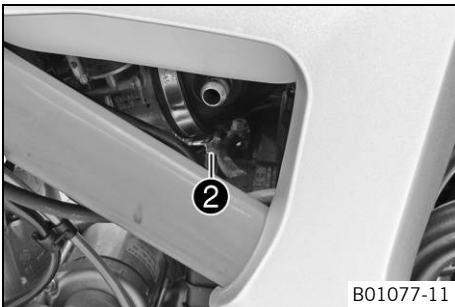

- Position the fuel tank.
- Position the intake flange on the throttle valve body.
- Tighten hose clamp ②.

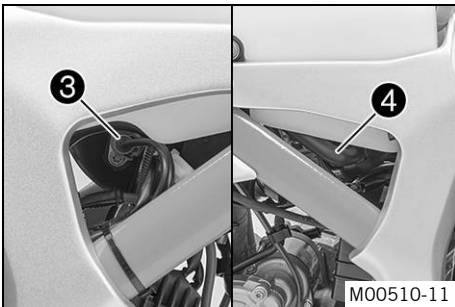

- Plug in connector ③.
- Position engine breather hose ④.

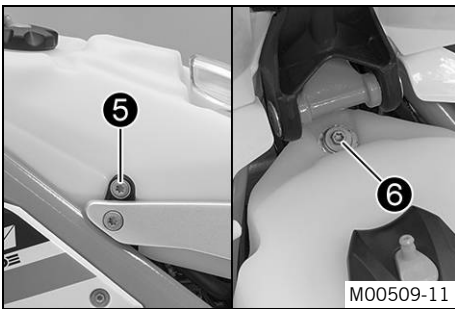

- Mount and tighten screws ⑤ on both sides.

Guideline

Screw, fuel tank	M8	15 Nm (11.1 lbf ft)	Loctite® 243™
------------------	----	------------------------	---------------

- Mount and tighten screw ⑥.

Guideline

Remaining screws, chassis	M6	10 Nm (7.4 lbf ft)
---------------------------	----	--------------------

- Mount the fuel tank breather.
- Thoroughly clean the plug-in connection of the fuel line using compressed air.



Info

Under no circumstances should dirt enter into the fuel line. Dirt in the fuel line clogs the injection valve.

- Remove the wash cap set. Lubricate the O-ring and connect the plug-in connection ⑦ for the fuel line.



Info

Route the cable and fuel line at a safe distance from the exhaust system.

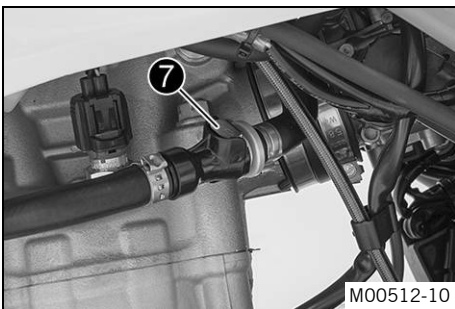

Finishing work

- Lock the seat. (☛ p. 45)

12.32 Checking for chain dirt accumulation

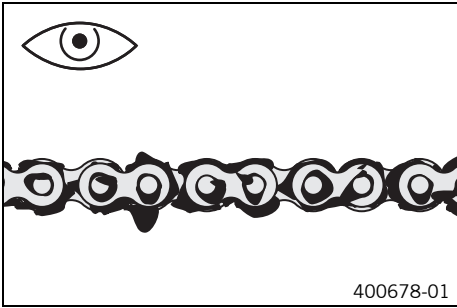

- Check the chain for coarse dirt accumulation.
 - » If the chain is very dirty:
 - Clean the chain. (☛ p. 53)

12.33 Cleaning the chain

Warning
Danger of accidents Oil or grease on the tires reduces their grip.
 - Remove oil and grease with a suitable cleaning material.

Warning
Danger of accidents Reduced braking efficiency due to oil or grease on the brake discs.
 - Always keep the brake discs free of oil and grease, and clean them with brake cleaner when necessary.

Warning
Environmental hazard Hazardous substances cause environmental damage.
 - Oil, grease, filters, fuel, cleaners, brake fluid, etc., should be disposed of as stipulated in applicable regulations.

i Info
 The service life of the chain depends largely on its maintenance.

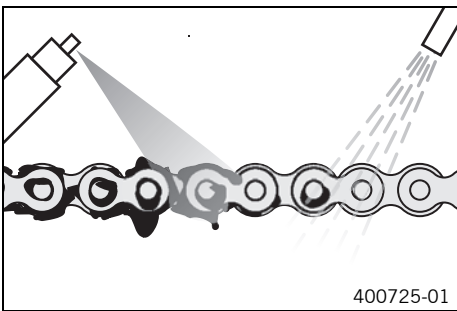

Preparatory work
 - Raise the motorcycle with the lift stand. (☛ p. 37)

Main work
 - Clean the chain regularly and then treat with chain spray.

Chain cleaner (☛ p. 105)
Off-road chain spray (☛ p. 105)

Finishing work
 - Remove the motorcycle from the lift stand. (☛ p. 37)

12.34 Checking the chain tension

Warning
Danger of accidents Danger caused by incorrect chain tension.
 - If the chain is too taut, the components of the secondary power transmission (chain, engine sprocket, rear sprocket, bearings in the transmission and in the rear wheel) will be under additional load. In addition to premature wear, this can cause the chain or the countershaft of the transmission to break in extreme cases. If the chain is too loose, however, it may fall off the engine sprocket or rear sprocket and block the rear wheel or damage the engine. Ensure that the chain tension is correct and adjust it if necessary.

Preparatory work
 - Raise the motorcycle with the lift stand. (☛ p. 37)

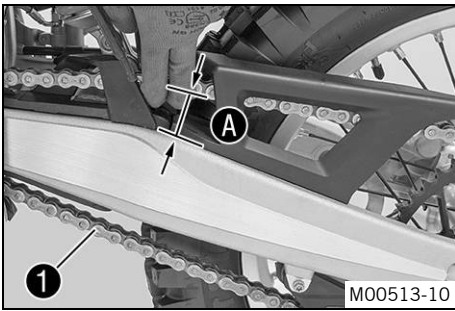

Main work

- Pull the chain at the end of the chain sliding component upwards to measure chain tension **A**.

i Info

The lower chain section **1** must be taut. Chain wear is not always even, so you should repeat this measurement at different chain positions.

Chain tension	36... 40 mm (1.42... 1.57 in)
---------------	-------------------------------

- » If the chain tension does not meet specifications:
 - Adjust the chain tension. (☛ p. 54)

Finishing work

- Remove the motorcycle from the lift stand. (☛ p. 37)

12.35 Adjusting the chain tension



Warning

Danger of accidents Danger caused by incorrect chain tension.

- If the chain is too taut, the components of the secondary power transmission (chain, engine sprocket, rear sprocket, bearings in the transmission and in the rear wheel) will be under additional load. In addition to premature wear, this can cause the chain or the countershaft of the transmission to break in extreme cases. If the chain is too loose, however, it may fall off the engine sprocket or rear sprocket and block the rear wheel or damage the engine. Ensure that the chain tension is correct and adjust it if necessary.

Preparatory work

- Raise the motorcycle with the lift stand. (☛ p. 37)
- Check the chain tension. (☛ p. 53)

Main work

- Loosen nut **1**.
- Loosen nuts **2**.
- Adjust the chain tension by turning adjusting screws **3** on the left and right.

Guideline

Chain tension	36... 40 mm (1.42... 1.57 in)	
Turn adjusting screws 3 on the left and right so that the markings on the left and right chain adjusters are in the same position relative to reference marks A . The rear wheel is then correctly aligned.		

- Tighten nuts **2**.
- Make sure that chain adjusters **4** are fitted correctly on adjusting screws **3**.
- Tighten nut **1**.

Guideline

Nut, rear wheel spindle	M20x1.5	80 Nm (59 lbf ft)
-------------------------	---------	-------------------

i Info

The wide adjustment range of the chain adjusters enables different secondary ratios with the same chain length. Chain adjusters **4** can be turned by 180°.

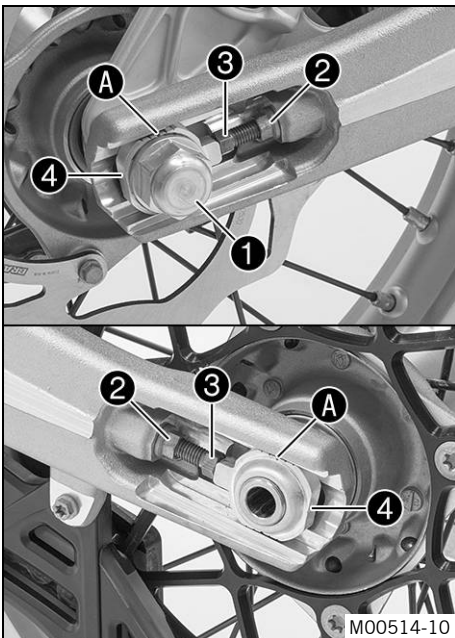

Finishing work

- Remove the motorcycle from the lift stand. (☛ p. 37)

12.36 Checking the chain, rear sprocket, engine sprocket and chain guide

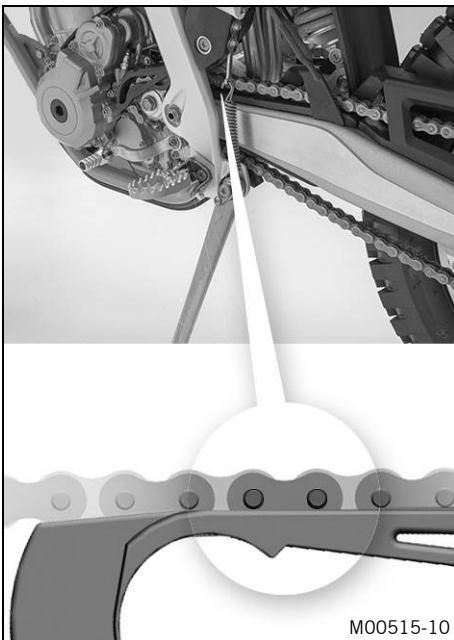
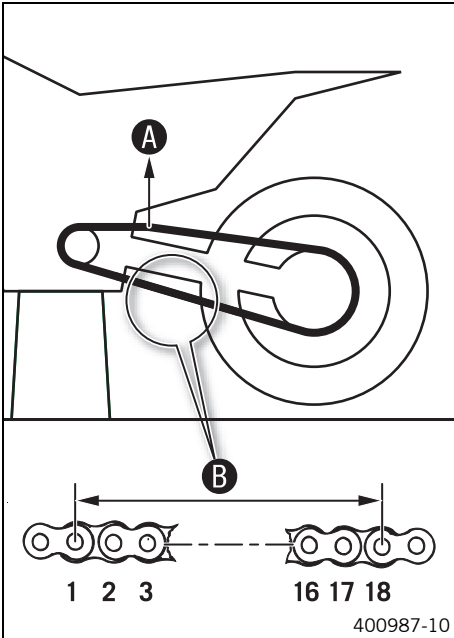
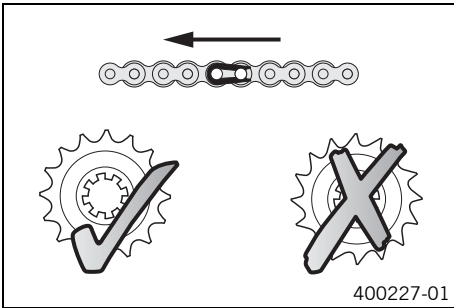

Preparatory work

- Raise the motorcycle with the lift stand. (☛ p. 37)

Main work

- Shift gear to neutral.
- Check the rear sprocket and engine sprocket for wear.
 - » If the rear sprocket and engine sprocket are worn:
 - Change the drivetrain kit. ☛



Info

The engine sprocket, rear sprocket and chain should always be replaced together.

- Pull on the upper part of the chain with the specified weight **A**.

Guideline

Weight, chain wear measurement	10... 15 kg (22... 33 lb.)
--------------------------------	----------------------------

- Measure the distance **B** of 18 chain links in the lower chain section.



Info

Chain wear is not always even, so you should repeat this measurement at different chain positions.

Maximum distance B at the longest chain section	272 mm (10.71 in)
--	-------------------

- » If the distance **B** is greater than the specified measurement:

- Change the drivetrain kit. ☛



Info

When the chain is replaced, the rear sprocket and engine sprocket should also be changed.
New chains wear out faster on old, worn sprockets.

- Check the chain sliding guard for wear.

- » If the bottom edge of the chain bolt is in line with or below the chain sliding guard:
 - Change the chain sliding guard. ☛

- Check that the chain sliding guard is firmly seated.

- » If the chain sliding guard is loose:
 - Tighten the chain sliding guard.

Guideline

Remaining screws, chassis	M6	10 Nm (7.4 lbf ft)
---------------------------	----	-----------------------

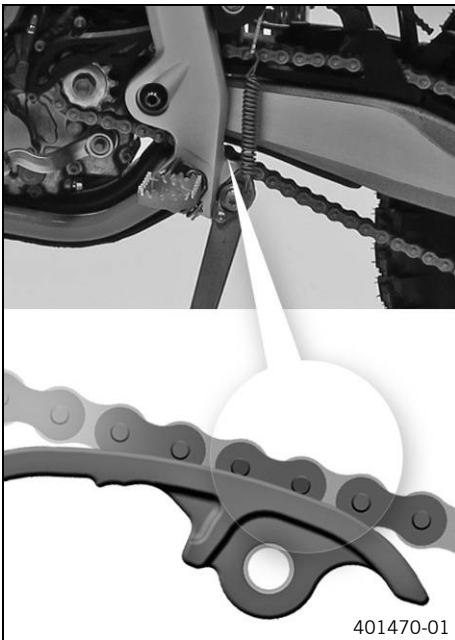

- Check the chain sliding piece for wear.
 - » If the bottom edge of the chain bolt is in line with or below the chain sliding piece:
 - Change the chain sliding piece. 🛠️
- Check that the chain sliding piece is firmly seated.
 - » If the chain sliding piece is loose:
 - Tighten the chain sliding piece.

Guideline

Screw, chain sliding piece	M8	15 Nm (11.1 lbf ft)
----------------------------	----	------------------------

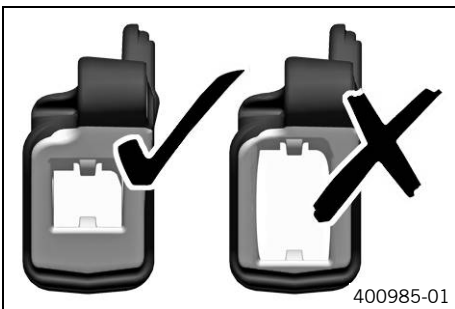

- Check the chain guide for wear.



Info

Wear can be seen on the front of the chain guide.

- » If the light part of the chain guide is worn:
 - Change the chain guide. 🛠️



- Check that the chain guide is firmly seated.
 - » If the chain guide is loose:
 - Tighten the chain guide.

Guideline

Remaining screws, chassis	M6	10 Nm (7.4 lbf ft)
Remaining nuts, chassis	M6	10 Nm (7.4 lbf ft)

Finishing work

- Remove the motorcycle from the lift stand. (👉 p. 37)

12.37 Checking the frame 🛠️

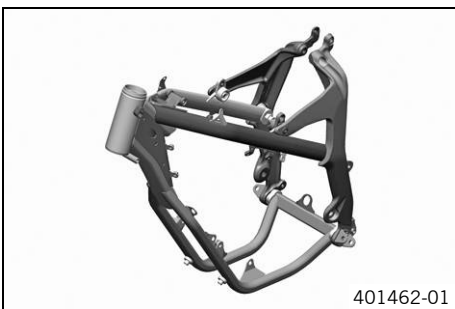

- Check the frame for cracking and deformation.
 - » If the frame exhibits cracking or deformation due to a mechanical impact:
 - Change the frame. 🛠️



Info

A frame that has been damaged due to a mechanical impact must be replaced. Repair of the frame is not authorized by KTM.

12.38 Checking the swingarm ↩



- Check the swingarm for damage, cracking, and deformation.
 - » If the swingarm shows signs of damage, cracking, or deformation:
 - Change the swingarm. ↩



Info

A damaged swingarm must always be changed. Repair of the swingarm is not authorized by KTM.

12.39 Checking the throttle cable routing



Preparatory work

- Fold the seat up. (↩ p. 45)
- Remove the fuel tank. ↩ (↩ p. 50)

Main work

- Check the throttle cable routing.

Both throttle cables must be routed to the throttle valve body side by side behind the handlebars and below the seat fixing.

- » If the throttle cable is not routed as specified:
 - Correct the throttle cable routing.

Finishing work

- Install the fuel tank. ↩ (↩ p. 51)
- Lock the seat. (↩ p. 45)

12.40 Checking the rubber grip

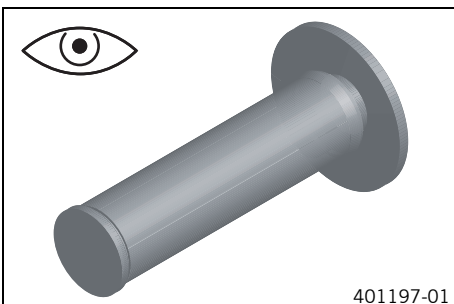

- Check the rubber grips on the handlebar for damage and wear and to ensure they are firmly seated.
 - » If a rubber grip is damaged, worn, or loose:
 - Change and secure the rubber grip.

Rubber grip adhesive (00062030051) (↩ p. 105)

12.41 Additionally securing the rubber grip

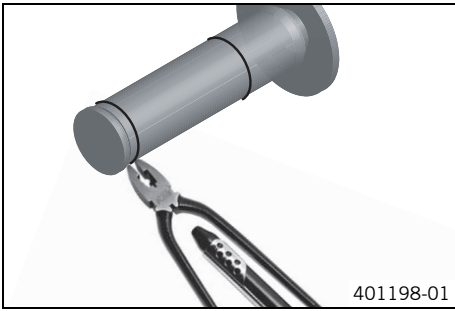

Preparatory work

- Check the rubber grip. (☛ p. 57)

Main work

- Secure the rubber grip at two points using the securing wire.

Securing wire (54812016000)

Wire twister forceps (U6907854)

- ✓ The twisted wire ends face away from the hands and are bent toward the rubber grip.

12.42 Adjusting the basic position of the clutch lever

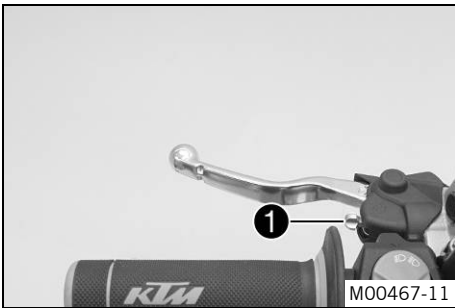

- Adjust the basic position of the clutch lever to your hand size by turning adjusting screw ①.

Info

When the adjusting screw is turned clockwise, the clutch lever moves away from the handlebar.

When the adjusting screw is turned counterclockwise, the clutch lever moves closer to the handlebar.

The range of adjustment is limited.

Turn the adjusting screw by hand only, and do not apply force.

Do not make any adjustments while riding!

12.43 Checking fluid level of the hydraulic clutch

Info

The fluid level rises with increasing wear of the clutch facing discs.

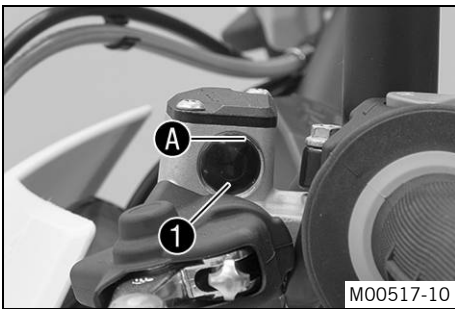

- Move the clutch fluid reservoir mounted on the handlebar into a horizontal position.
- Check the fluid level in viewer ①.
 - » If the fluid has dropped below marking A in the level viewer:
 - Correct the fluid level of the hydraulic clutch. (☛ p. 58)

12.44 Correcting the fluid level of the hydraulic clutch

Info

The fluid level rises with increasing wear of the clutch facing discs.

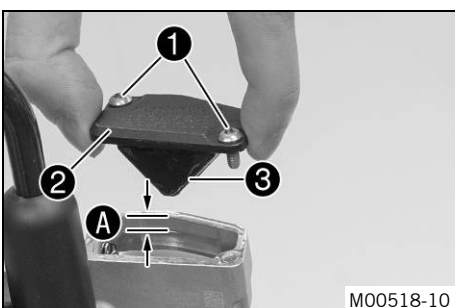

- Move the clutch fluid reservoir mounted on the handlebar to a horizontal position.
- Remove screws ①.
- Remove cover ② with membrane ③.
- Add fluid to level A.

Guideline

Level A (fluid level below container rim)	4 mm (0.16 in)
---	----------------

4 mm (0.16 in)

Brake fluid DOT 4 / DOT 5.1 (☛ p. 103)
--

- Position the cover with the membrane. Mount and tighten the screws.



Info

Clean up overflowed or spilt brake fluid immediately with water.

12.45 Changing the hydraulic clutch fluid



Warning

Environmental hazard Hazardous substances cause environmental damage.

- Oil, grease, filters, fuel, cleaners, brake fluid, etc., should be disposed of as stipulated in applicable regulations.

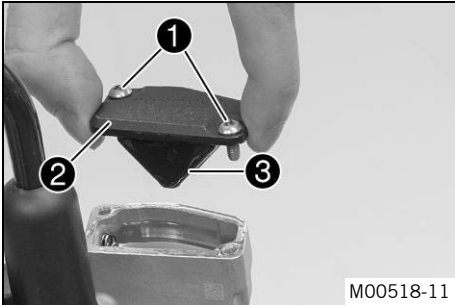

- Move the clutch fluid reservoir mounted on the handlebar to a horizontal position.
- Remove screws ①.
- Remove cover ② with membrane ③.

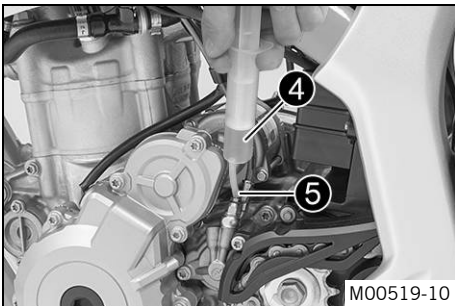

- Fill bleeding syringe ④ with the appropriate hydraulic fluid.

Bleed syringe (50329050000)

Brake fluid DOT 4 / DOT 5.1 (☛ p. 103)
--

- On the clutch slave cylinder, remove bleeder screw ⑤ and mount bleeding syringe ④.

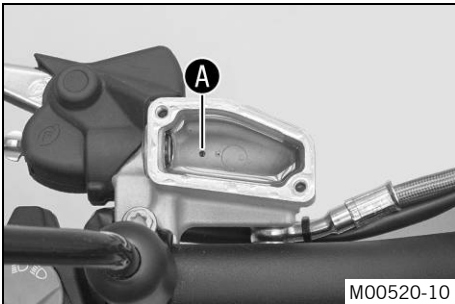

- Inject the liquid into the system until it escapes from opening A of the master cylinder without bubbles.
- To prevent overflow, drain fluid occasionally from the master cylinder reservoir.
- Remove the bleeding syringe. Mount and tighten screws bleeder screw.
- Correct the fluid level of the hydraulic clutch.

Guideline

Fluid level below container rim	4 mm (0.16 in)
---------------------------------	----------------

- Position the cover with the membrane. Mount and tighten the screws.

12.46 Removing the engine guard

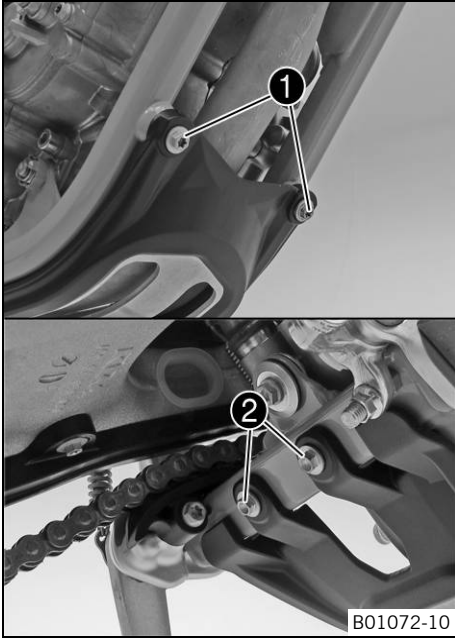

- Remove screws ❶ and ❷.
- Lower the engine guard at the rear and remove it toward the front.

12.47 Installing the engine guard

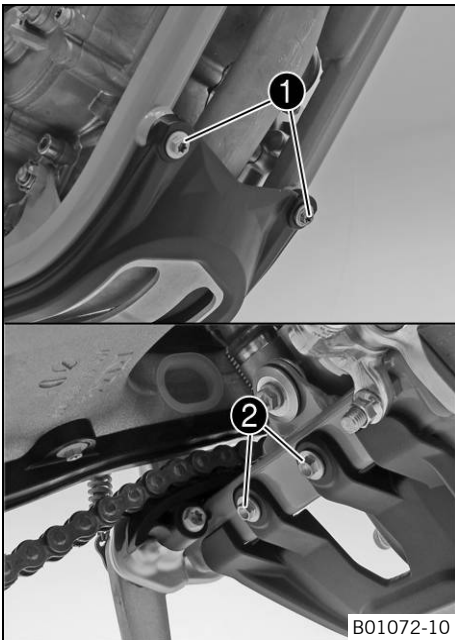

- Position the engine guard on the frame at the front and mount screws ❶ but do not tighten yet.
- Position the engine guard on the frame at the rear and mount and tighten screws ❷.

Guideline

Remaining screws, chassis	M6	10 Nm (7.4 lbf ft)
---------------------------	----	--------------------

- Tighten screws ❶.

Guideline

Remaining screws, chassis	M6	10 Nm (7.4 lbf ft)
---------------------------	----	--------------------

13.1 Checking the free travel of the hand brake lever

Warning
Danger of accidents Brake system failure.

- If there is no free travel on the hand brake lever, pressure builds up on the front brake circuit. The front brake can fail due to overheating. Adjust the free travel on hand brake lever according to specifications.

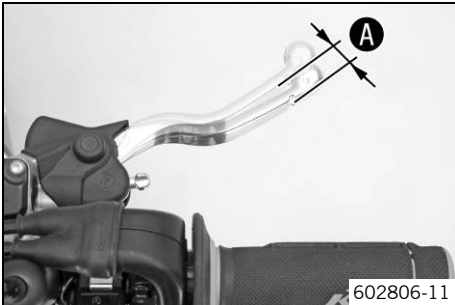

- Push the hand brake to the handlebar and check free travel **A**.

Free travel of hand brake lever	$\geq 3 \text{ mm } (\geq 0.12 \text{ in})$
---------------------------------	---

- » If the free travel does not meet specifications:
 - Adjust the free travel of the handbrake lever. (☛ p. 61)

13.2 Adjusting the free travel of the handbrake lever

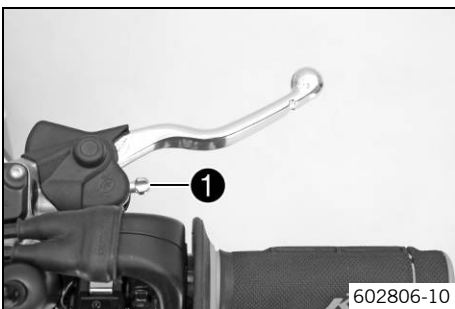

- Check the free travel of the hand brake lever. (☛ p. 61)
- Adjust the free travel of the handbrake lever with adjustment screw **1**.

i Info
 When the adjusting screw is turned clockwise, the free travel decreases. The pressure point moves away from the handlebar.
 When the adjusting screw is turned counterclockwise, the free travel increases. The pressure point moves towards the handlebar.
 The range of adjustment is limited.
 Turn the adjusting screw by hand only, and do not apply force.
 Do not make any adjustments while riding!

13.3 Checking the brake discs

Warning
Danger of accidents Reduced braking efficiency due to worn brake disc(s).

- Change the worn brake disc(s) without delay. (Your authorized KTM workshop will be glad to help.)

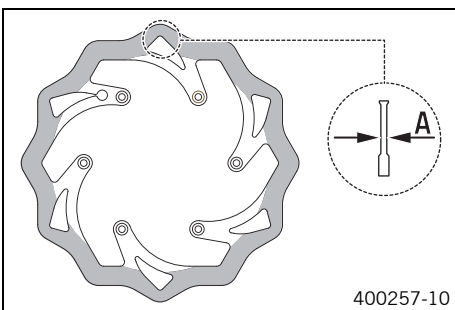

- Check the thickness of the front and rear brake discs at several places on the disk to see if it conforms to measurement **A**.

i Info
 Wear reduces the thickness of the brake disc around the area used by the brake linings.

Brake discs - wear limit	
Front	2.5 mm (0.098 in)
Rear	3.5 mm (0.138 in)

- » If the brake disc thickness is less than the specified value:
 - Change the brake disc.
- Check the front and rear brake discs for damage, cracking and deformation.
 - » If the brake disc shows signs of damage, cracking, or deformation:
 - Change the brake disc.

13.4 Checking the brake fluid level of the front brake



Warning

Danger of accidents Brake system failure.

- If the brake fluid level drops below the specified marking or the specified value, this is an indication that the brake system is leaking or that the brake linings are completely worn down. Check the brake system and do not continue riding. (Your authorized KTM workshop will be glad to help.)



Warning

Danger of accidents Reduced braking efficiency due to old brake fluid.

- Change the brake fluid of the front and rear brake according to the service schedule. (Your authorized KTM workshop will be glad to help.)

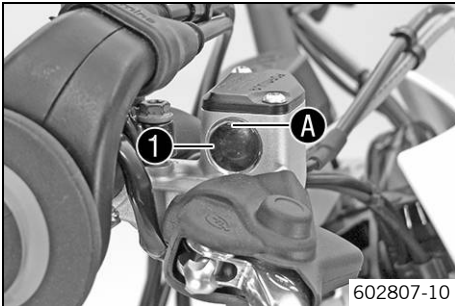

- Move the brake fluid reservoir mounted on the handlebar to a horizontal position.
- Check the brake fluid level in the viewer **1**.
 - » If the brake fluid has dropped below marking **A**:
 - Add front brake fluid. ↘ (↖ p. 62)

13.5 Adding front brake fluid ↘



Warning

Danger of accidents Brake system failure.

- If the brake fluid level drops below the specified marking or the specified value, this is an indication that the brake system is leaking or that the brake linings are completely worn down. Check the brake system and do not continue riding. (Your authorized KTM workshop will be glad to help.)



Warning

Skin irritation Brake fluid can cause skin irritation on contact.

- Avoid contact with skin and eyes, and keep out of the reach of children.
- Wear suitable protective clothing and goggles.
- If brake fluid comes into contact with the eyes, flush the eyes thoroughly with water and consult a physician immediately.



Warning

Danger of accidents Reduced braking efficiency due to old brake fluid.

- Change the brake fluid of the front and rear brake according to the service schedule. (Your authorized KTM workshop will be glad to help.)



Warning

Environmental hazard Hazardous substances cause environmental damage.

- Oil, grease, filters, fuel, cleaners, brake fluid, etc., should be disposed of as stipulated in applicable regulations.



Info

Never use DOT 5 brake fluid! It is silicone-based and purple in color. Oil seals and brake lines are not designed for DOT 5 brake fluid.

Avoid contact between brake fluid and painted parts. Brake fluid attacks paint!

Use only clean brake fluid from a sealed container.

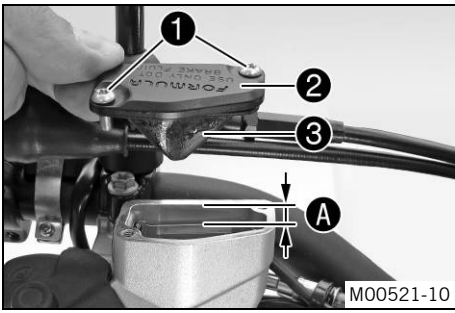

- Move the brake fluid reservoir mounted on the handlebar to a horizontal position.
- Remove screws ①.
- Remove cover ② with membrane ③.
- Add brake fluid to level A.

Guideline

Level A (brake fluid level below container rim)	5 mm (0.2 in)
---	---------------

Brake fluid DOT 4 / DOT 5.1 (☞ p. 103)
--

- Position the cover with the membrane. Mount and tighten the screws.

i Info
Clean up overflowed or spilled brake fluid immediately with water.

13.6 Checking the front brake linings

Warning
Danger of accidents Reduced braking efficiency caused by worn brake linings.

- Change worn brake linings immediately. (Your authorized KTM workshop will be glad to help.)

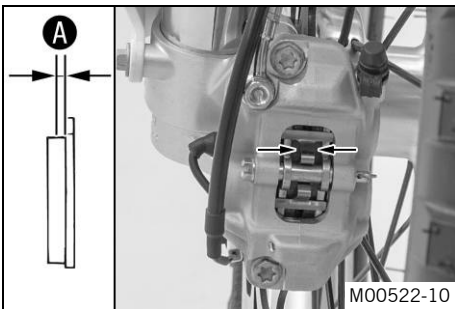

- Check the brake linings for minimum thickness A.

Minimum thickness A	≥ 1 mm (≥ 0.04 in)
---------------------	--------------------

- » If the minimum thickness is less than specified:
 - Change the front brake linings. ☞ (☞ p. 63)
- Check the brake linings for damage and cracking.
 - » If damage or cracking is visible:
 - Change the front brake linings. ☞ (☞ p. 63)

13.7 Changing the front brake linings ☞

Warning
Danger of accident Brake system failure.

- Maintenance work and repairs must be carried out professionally. (Your authorized KTM workshop will be glad to help.)

Warning
Skin irritation Brake fluid can cause skin irritation on contact.

- Avoid contact with skin and eyes, and keep out of the reach of children.
- Wear suitable protective clothing and goggles.
- If brake fluid comes into contact with the eyes, flush the eyes thoroughly with water and consult a physician immediately.

Warning
Danger of accidents Reduced braking efficiency due to old brake fluid.

- Change the brake fluid of the front and rear brake according to the service schedule. (Your authorized KTM workshop will be glad to help.)

Warning
Danger of accidents Reduced braking efficiency due to oil or grease on the brake discs.

- Always keep the brake discs free of oil and grease, and clean them with brake cleaner when necessary.

Warning
Danger of accidents Reduced braking efficiency due to use of non-approved brake linings.

- Brake linings available from accessory suppliers are often not tested and approved for use on KTM vehicles. The construction and friction factor of the brake linings and therefore the brake power can differ considerably from the original KTM brake linings. If brake linings are used that differ from the originals, there is no guarantee that they comply with the original license. The vehicle no longer corresponds to the condition at delivery, and the warranty is no longer valid.



Warning

Environmental hazard Hazardous substances cause environmental damage.

- Oil, grease, filters, fuel, cleaners, brake fluid, etc., should be disposed of as stipulated in applicable regulations.



Info

Never use DOT 5 brake fluid! It is silicone-based and purple in color. Oil seals and brake lines are not designed for DOT 5 brake fluid.

Avoid contact between brake fluid and painted parts. Brake fluid attacks paint!

Use only clean brake fluid from a sealed container.

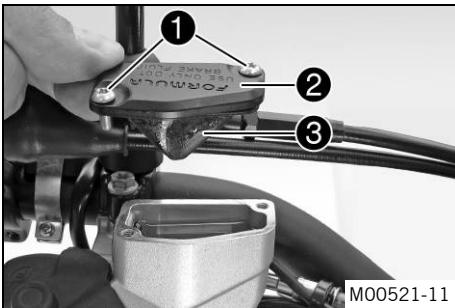

M00521-11

- Move the brake fluid reservoir mounted on the handlebar to a horizontal position.
- Remove screws ①.
- Remove cover ② with membrane ③.

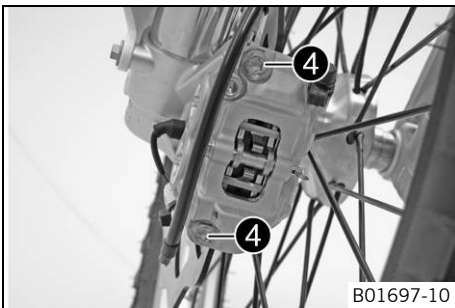

B01697-10

- Remove screws ④ and spacers.
- Press back the brake linings with a light lateral tilting of the brake caliper on the brake disc. Carefully pull the brake caliper backwards from the brake disc..
- Press the brake piston back to its basic position and make sure that no brake fluid overflows from the brake fluid reservoir.

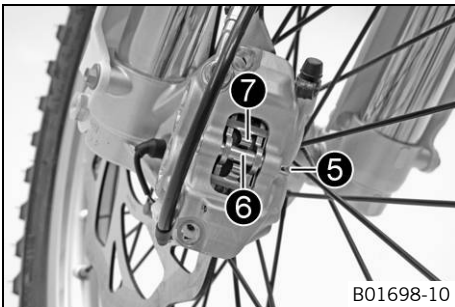

B01698-10

- Remove cotter pin ⑤.
- Remove pin ⑥.
- Take off retaining spring ⑦ and remove the brake linings.
- Clean the brake caliper.
- Position the new brake linings.



Info

Always change the full set of brake linings.

- Position retaining spring ⑦.
- Mount bolt ⑥.



Info

To make it easier to mount the pin, push the retainer spring down. Make sure the retaining spring is seated correctly.

- Mount cotter pin ⑤.
- Position the brake caliper. Mount screws ④ with the spacers but do not tighten yet.
- Operate the hand brake lever repeatedly until the brake linings are in contact with the brake disc and there is a pressure point. Fix the hand brake lever in the activated position.

✓ The brake caliper straightens.

- Tighten screws ④.

Guideline

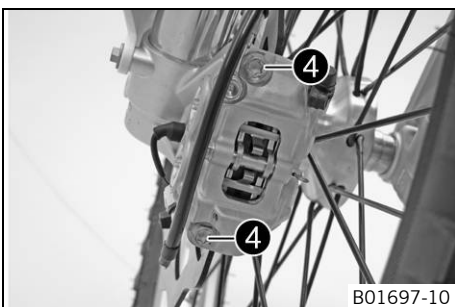

B01697-10

Screw, front brake caliper	M8	25 Nm (18.4 lbf ft)	Loctite® 243™
----------------------------	----	------------------------	---------------

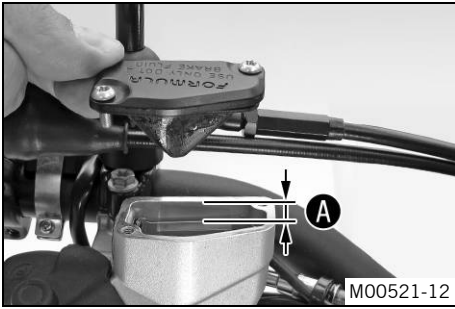

- Remove the fixation of the hand brake lever.
- Add brake fluid to level **A**.

Guideline

Level A (brake fluid level below container rim)	5 mm (0.2 in)
--	---------------

Brake fluid DOT 4 / DOT 5.1 (☞ p. 103)
--

- Position the cover with the membrane. Mount and tighten the screws.

i Info
Clean up overflowed or spilt brake fluid immediately with water.

13.8 Checking the free travel of foot brake lever

Warning
Danger of accidents Brake system failure.

- If there is no free travel on the foot brake lever, pressure builds up on the rear brake circuit. The rear brake can fail due to overheating. Adjust the free travel on foot brake lever according to specifications.

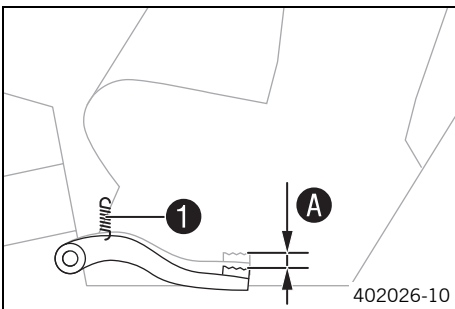

- Disconnect spring **1**.
- Move the foot brake lever back and forth between the end stop and the contact to the foot brake cylinder piston and check free travel **A**.

Guideline

Free travel at foot brake lever	3... 5 mm (0.12... 0.2 in)
---------------------------------	----------------------------

- » If the free travel does not meet specifications:
 - Adjust the basic position of the foot brake lever. ☞ (☞ p. 65)
- Reconnect spring **1**.

13.9 Adjusting the basic position of the foot brake lever ☞

Warning
Danger of accidents Brake system failure.

- If there is no free travel on the foot brake lever, pressure builds up on the rear brake circuit. The rear brake can fail due to overheating. Adjust the free travel on foot brake lever according to specifications.

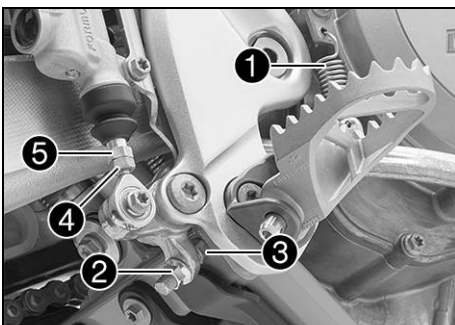

- Disconnect spring **1**.
- Loosen nut **4** and, with push rod **5**, turn it back until you have maximum free travel.
- To adjust the basic position of the foot brake lever individually, loosen nut **2** and turn screw **3** accordingly.

i Info
The range of adjustment is limited.

- Turn push rod **5** accordingly until you have free travel **A**. If necessary, adjust the basic position of the foot brake lever.

Guideline

Free travel at foot brake lever	3... 5 mm (0.12... 0.2 in)
---------------------------------	----------------------------

- Hold screw **3** and tighten nut **2**.

Guideline

Nut, foot brake lever stop	M8	20 Nm (14.8 lbf ft)
----------------------------	----	---------------------

- Hold push rod **5** and tighten nut **4**.

Guideline

Remaining nuts, chassis	M6	10 Nm (7.4 lbf ft)
-------------------------	----	--------------------

- Reconnect spring ①.

13.10 Checking the rear brake fluid level



Warning

Danger of accidents Brake system failure.

- If the brake fluid level drops below the specified marking or the specified value, this is an indication that the brake system is leaking or that the brake linings are completely worn down. Check the brake system and do not continue riding. (Your authorized KTM workshop will be glad to help.)



Warning

Danger of accidents Reduced braking efficiency due to old brake fluid.

- Change the brake fluid of the front and rear brake according to the service schedule. (Your authorized KTM workshop will be glad to help.)

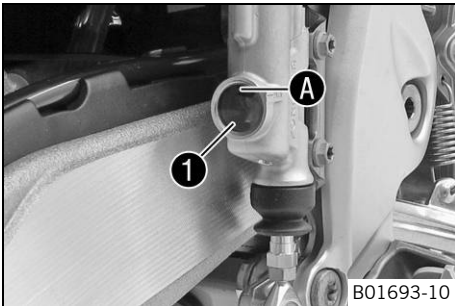

- Stand the vehicle upright.
- Check the brake fluid level in the viewer ①.
 - » If the brake fluid level drops below marking A:
 - Add rear brake fluid. ↗ (↖ p. 66)

13.11 Adding rear brake fluid ↗



Warning

Danger of accidents Brake system failure.

- If the brake fluid level drops below the specified marking or the specified value, this is an indication that the brake system is leaking or that the brake linings are completely worn down. Check the brake system and do not continue riding. (Your authorized KTM workshop will be glad to help.)



Warning

Skin irritation Brake fluid can cause skin irritation on contact.

- Avoid contact with skin and eyes, and keep out of the reach of children.
- Wear suitable protective clothing and goggles.
- If brake fluid comes into contact with the eyes, flush the eyes thoroughly with water and consult a physician immediately.



Warning

Danger of accidents Reduced braking efficiency due to old brake fluid.

- Change the brake fluid of the front and rear brake according to the service schedule. (Your authorized KTM workshop will be glad to help.)



Warning

Environmental hazard Hazardous substances cause environmental damage.

- Oil, grease, filters, fuel, cleaners, brake fluid, etc., should be disposed of as stipulated in applicable regulations.



Info

Never use DOT 5 brake fluid! It is silicone-based and purple in color. Oil seals and brake lines are not designed for DOT 5 brake fluid.

Avoid contact between brake fluid and painted parts. Brake fluid attacks paint!

Use only clean brake fluid from a sealed container.

Preparatory work

- Check the rear brake linings. (↖ p. 67)

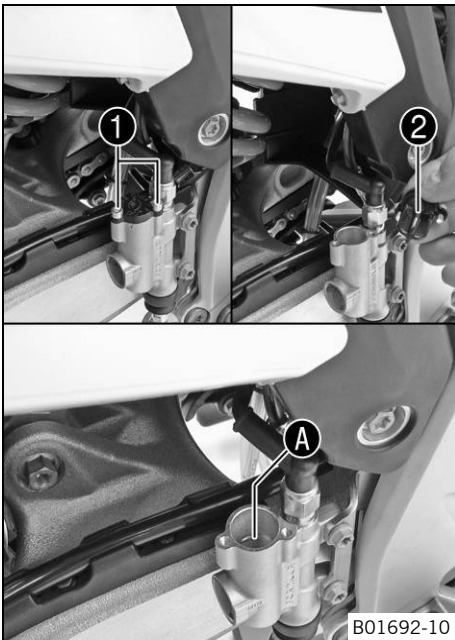

Main work

- Stand the vehicle upright.
- Remove screws ①.
- Remove cover with membrane ②.
- Add brake fluid to level A.

Brake fluid DOT 4 / DOT 5.1 (☞ p. 103)
--

- Position the cover with the membrane.
- Mount and tighten the screws.

i Info

Clean up overflowed or spilt brake fluid immediately with water.

13.12 Checking the rear brake linings

Warning

Danger of accidents Reduced braking efficiency caused by worn brake linings.

- Change worn brake linings immediately. (Your authorized KTM workshop will be glad to help.)

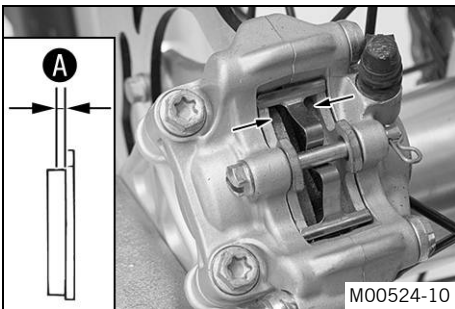

- Check the brake linings for minimum thickness A.

Minimum thickness A	≥ 1 mm (≥ 0.04 in)
---------------------	--------------------

- » If the minimum thickness is less than specified:
 - Change the rear brake linings. ☞ (☞ p. 67)
- Check the brake linings for damage and cracking.
 - » If damage or cracking is visible:
 - Change the rear brake linings. ☞ (☞ p. 67)

13.13 Changing the rear brake linings ☞

Warning

Danger of accident Brake system failure.

- Maintenance work and repairs must be carried out professionally. (Your authorized KTM workshop will be glad to help.)

Warning

Skin irritation Brake fluid can cause skin irritation on contact.

- Avoid contact with skin and eyes, and keep out of the reach of children.
- Wear suitable protective clothing and goggles.
- If brake fluid comes into contact with the eyes, flush the eyes thoroughly with water and consult a physician immediately.

Warning

Danger of accidents Reduced braking efficiency due to old brake fluid.

- Change the brake fluid of the front and rear brake according to the service schedule. (Your authorized KTM workshop will be glad to help.)

Warning

Danger of accidents Reduced braking efficiency due to oil or grease on the brake discs.

- Always keep the brake discs free of oil and grease, and clean them with brake cleaner when necessary.



Warning

Danger of accidents Reduced braking efficiency due to use of non-approved brake linings.

- Brake linings available from accessory suppliers are often not tested and approved for use on KTM vehicles. The construction and friction factor of the brake linings and therefore the brake power can differ considerably from the original KTM brake linings. If brake linings are used that differ from the originals, there is no guarantee that they comply with the original license. The vehicle no longer corresponds to the condition at delivery, and the warranty is no longer valid.



Warning

Environmental hazard Hazardous substances cause environmental damage.

- Oil, grease, filters, fuel, cleaners, brake fluid, etc., should be disposed of as stipulated in applicable regulations.



Info

Never use DOT 5 brake fluid! It is silicone-based and purple in color. Oil seals and brake lines are not designed for DOT 5 brake fluid.

Avoid contact between brake fluid and painted parts. Brake fluid attacks paint!

Use only clean brake fluid from a sealed container.

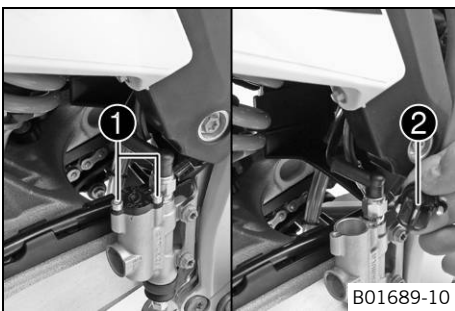

- Stand the vehicle upright.
- Remove screws **1**.
- Remove cover with membrane **2**.
- Press the brake piston back to its basic position and make sure that no brake fluid overflows from the brake fluid reservoir.

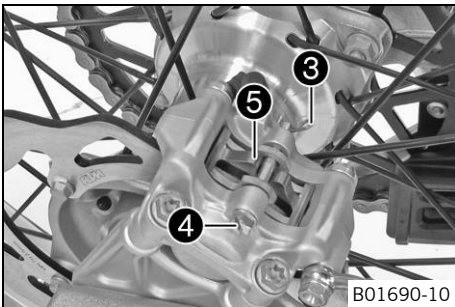

- Remove cotter pins **3**.
- Remove pins **4**.
- Take off retaining spring **5** and remove the brake linings.
- Clean the brake caliper.

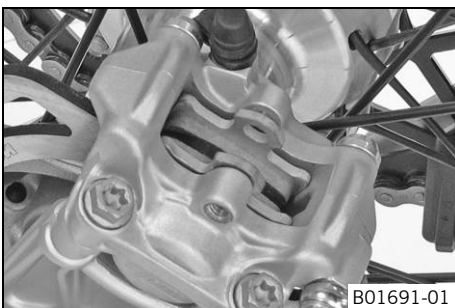

- Position the new brake linings.



Info

Always change the full set of brake linings.

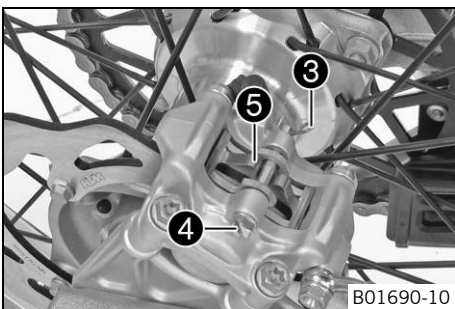

- Position retaining spring **5**.
- Mount bolt **4**.



Info

To make it easier to mount the pin, push the retainer spring down. Make sure the retaining spring is seated correctly.

- Mount cotter pin **3**.
- Operate the foot brake lever repeatedly until the brake linings are in contact with the brake disc and there is a pressure point.

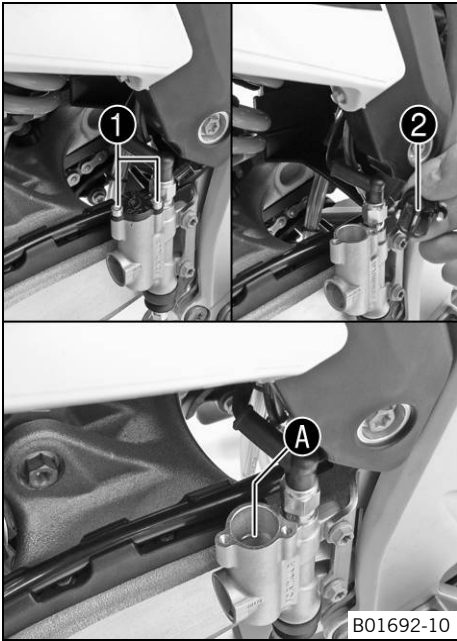

- Add brake fluid to level **A**.

Brake fluid DOT 4 / DOT 5.1 (☛ p. 103)

- Position the cover with the membrane **2**.
- Mount and tighten screws **1**.

i **Info**

Clean up overflowed or spilt brake fluid immediately with water.

14.1 Removing the front wheel

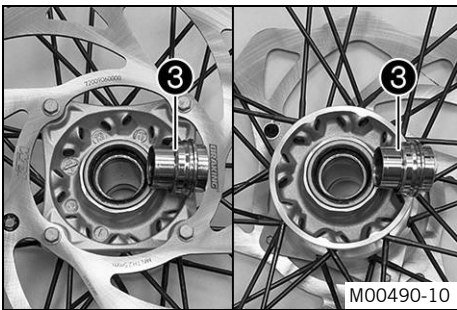
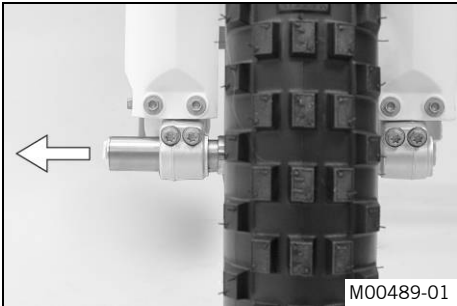
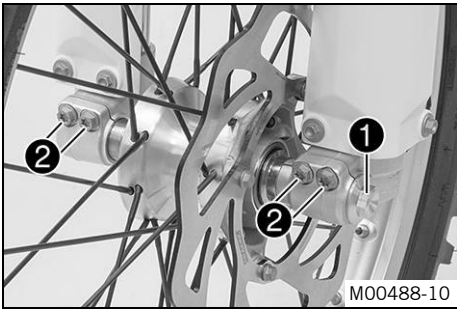

Preparatory work

- Raise the motorcycle with the lift stand. (☛ p. 37)

Main work

- Loosen screw ① by several rotations.
- Release screws ②.
- Press on screw ① to push the wheel spindle on the axle clamp.
- Remove screw ①.

- Holding the front wheel, withdraw the wheel spindle. Take the front wheel out of the fork.

i Info

Do not pull the hand brake lever when the front wheel is removed. Always lay the wheel down in such a way that the brake disc is not damaged.

- Remove spacers ③.

14.2 Installing the front wheel

! Warning

Danger of accidents Reduced braking efficiency due to oil or grease on the brake discs.

- Always keep the brake discs free of oil and grease, and clean them with brake cleaner when necessary.

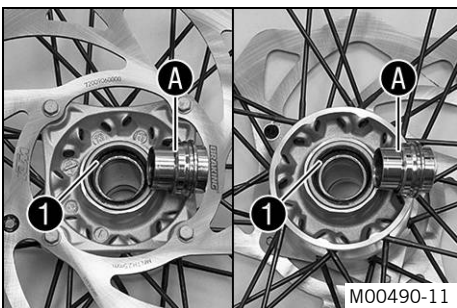

- Check the wheel bearing for damage and wear.
 - » If the wheel bearing is damaged or worn:
 - Change the front wheel bearing. ☛
- Clean and grease the shaft seal rings ① and contact surface A of the spacers.

Long-life grease (☛ p. 105)

- Insert the spacers.

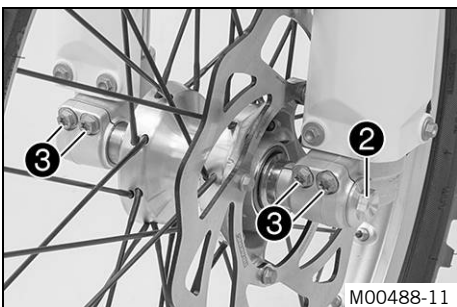

- Position the front wheel and insert the wheel spindle.
 - ✓ The brake linings are correctly positioned.
- Mount and tighten screw ②.

Guideline

Screw, front wheel spindle	M20x1.5	35 Nm (25.8 lbf ft)
----------------------------	---------	------------------------

- Activate the hand brake lever multiple times until the brake linings are in contact with the brake disc.
- Remove the motorcycle from the lift stand. (☛ p. 37)

- Pull the front brake and compress the fork forcefully a few times.
✓ The fork legs straighten.
- Tighten screw ③.

Guideline

Screw, fork stub	M8	15 Nm (11.1 lbf ft)
------------------	----	------------------------

14.3 Removing the rear wheel ↗

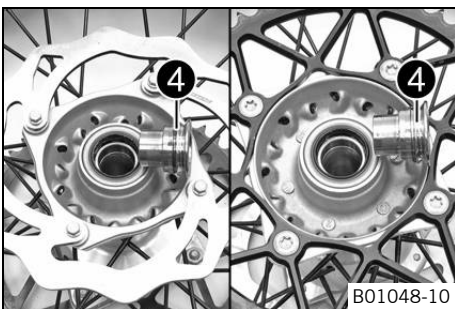
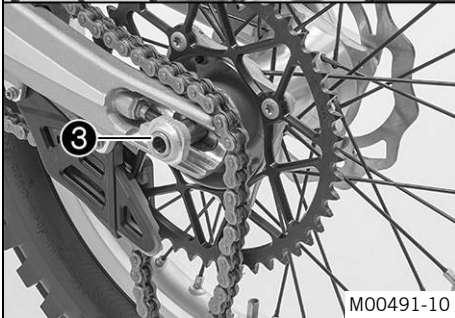
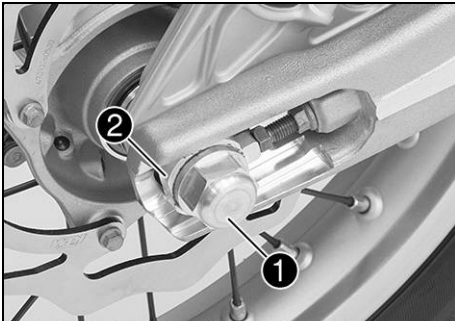

Preparatory work

- Raise the motorcycle with the lift stand. (☛ p. 37)

Main work

- Remove nut ①.
- Remove chain adjuster ②.
- Withdraw wheel spindle ③ only enough to allow the rear wheel to be pushed forward.
- Push the rear wheel forward as far as possible. Remove the chain from the rear sprocket.

i Info

Cover the components to protect them against damage.

- Holding the rear wheel, withdraw the wheel spindle. Take the rear wheel out of the swing arm.

i Info

Do not operate the foot brake when the rear wheel is removed. Always lay the wheel down in such a way that the brake disc is not damaged.

- Remove spacers ④.

14.4 Installing the rear wheel ↗



Warning

Danger of accidents Reduced braking efficiency due to oil or grease on the brake discs.

- Always keep the brake discs free of oil and grease, and clean them with brake cleaner when necessary.

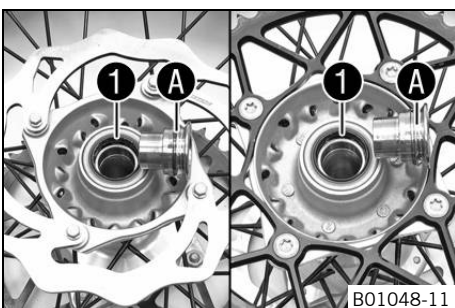

Main work

- Check the wheel bearing for damage and wear.
 - » If the wheel bearing is damaged or worn:
 - Change the rear wheel bearing. ↗
- Clean and grease the shaft seal rings ① and contact surface A of the spacers.

Long-life grease (☛ p. 105)

- Insert the spacers.

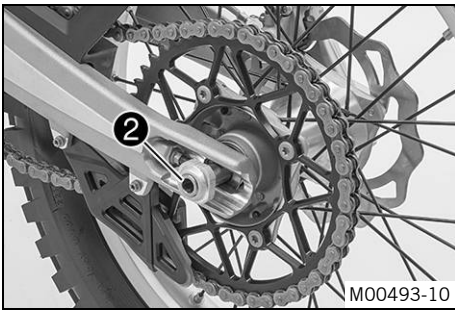

- Lift the rear wheel into the swingarm, position it, and insert wheel spindle ②.
- Put the chain on.
- ✓ The brake linings are correctly positioned.

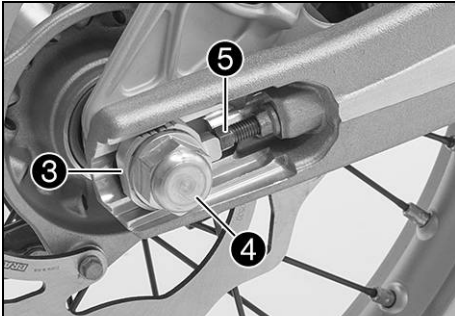

- Position chain adjuster ③. Mount nut ④, but do not tighten it yet.
- Make sure that chain adjusters ③ are fitted correctly on adjusting screws ⑤.
- Check the chain tension. (☛ p. 53)
- Tighten nut ④.

Guideline

Nut, rear wheel spindle	M20x1.5	80 Nm (59 lbf ft)
-------------------------	---------	-------------------

i Info
 The wide adjustment range of the chain adjusters enables different secondary ratios with the same chain length.
 Chain adjusters ③ can be turned by 180°.

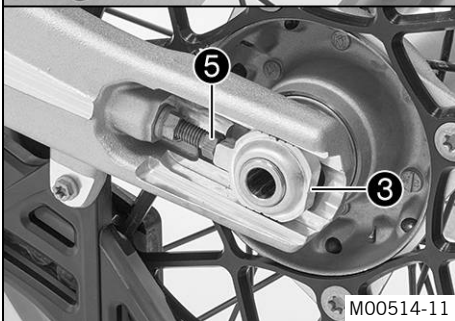

- Operate the foot brake lever repeatedly until the brake linings are in contact with the brake disc and there is a pressure point.

Finishing work

- Remove the motorcycle from the lift stand. (☛ p. 37)

14.5 Checking the tire condition

i Info
 Only mount tires approved and/or recommended by KTM.
 Other tires could have a negative effect on handling characteristics.
 The type, condition, and air pressure of the tires all have a major impact on the handling characteristics of the motorcycle.
 The tires mounted on the front and rear wheels must have a similar profile.
 Worn tires have a negative effect on riding behavior, especially on wet surfaces.
 If used regularly on public roads, tires wear much faster and the minimum tread depth and general condition of the tires must be checked more frequently.

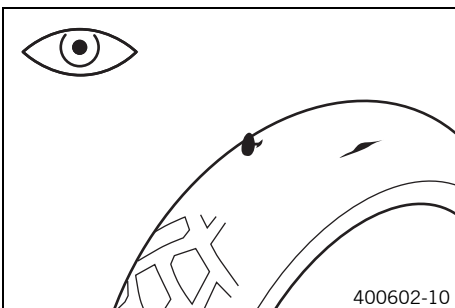

- Check the front and rear tires for cuts, run-in objects, and other damage.
 - » If the tires exhibit cuts, run-in objects, or other damage:
 - Change the tires.
- Check the depth of the tread.

i Info
 Note local national regulations concerning the minimum tread depth.

Minimum tread depth	≥ 2 mm (≥ 0.08 in)
---------------------	--------------------

- » If the tread depth is less than the minimum permissible depth:
 - Change the tires.
- Check the age of the tires.



Info

The tire's date of manufacture is usually part of the tire markings and is indicated by four digits. The first two digits refer to the week of manufacture and last two digits refer to the year of manufacture. KTM recommends that the tires be changed after 5 years at the latest, regardless of the actual state of wear.

- » If a tire is more than 5 years old:
 - Change the tires.

14.6 Checking the tire air pressure



Info

Low tire air pressure leads to abnormal wear and overheating of the tire. Correct tire air pressure ensures optimal riding comfort and maximum tire service life.

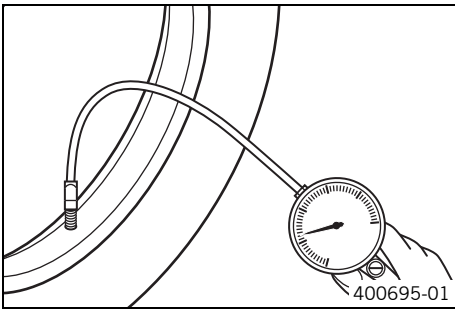

- Remove the protection cap.
- Check the tire air pressure when the tires are cold.

Tire air pressure, offroad	
Front	0.9 bar (13 psi)
Rear	0.7 bar (10 psi)

Tire air pressure, road	
Front	1.5 bar (22 psi)
Rear	1.5 bar (22 psi)

- » If the tire pressure does not meet specifications:
 - Correct the tire pressure.
- Mount protection cap.

14.7 Checking the spoke tension



Warning

Danger of accidents Instable handling due to incorrect spoke tension.

- Ensure that the spoke tension is correct. (Your authorized KTM workshop will be glad to help.)



Info

A loose spoke causes wheel imbalance and rapidly leads to more loose spokes. If the spokes are too tight, they can break due to local overload. Check the spoke tension regularly, especially on a new motorcycle.

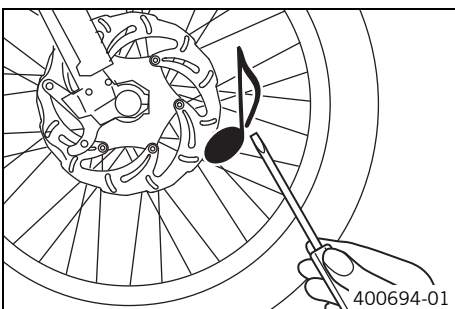

- Briefly strike each spoke with the tip of a screwdriver.



Info

The tone frequency depends on the length of the spoke and the spoke diameter. If you hear different tone frequencies from different spokes of equal length and diameter, this is an indication of different spoke tensions.

You should hear a high note.

- » If the spoke tension varies:
 - Correct the spoke tension. 🛠️
- Check the spoke torque.

Guideline

Spoke nipple	M4.5	6 Nm (4.4 lbf ft)
--------------	------	-------------------

Torque wrench with various accessories in set (58429094000)

15.1 Removing the battery

- Warning**
Risk of injury Battery acid and battery gases cause serious chemical burns.
- Keep batteries out of the reach of children.
 - Wear suitable protective clothing and goggles.
 - Avoid contact with battery acid and battery gases.
 - Keep sparks and open flames away from the battery. Only charge in well-ventilated rooms.
 - In the event of skin contact, rinse with large amounts of water. If battery acid gets in the eyes, rinse with water for at least 15 minutes and contact a physician.

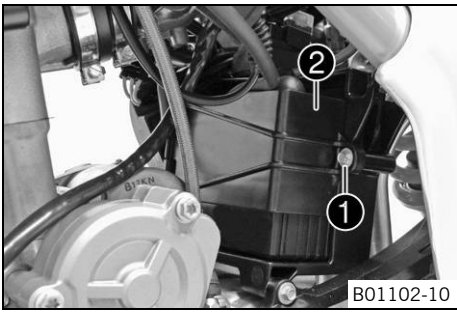

- Switch off all power consumers and switch off the engine.
- Remove screw 1.
- Remove fastening plate 2.

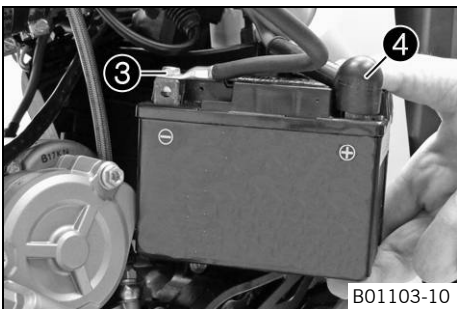

- Remove the battery from the battery compartment.
- Disconnect negative cable 3 from the battery.
- Pull back positive terminal cover 4 and disconnect the positive cable from the battery.

15.2 Installing the battery



- Position the positive cable and mount and tighten the screw.

Guideline

Screw, battery terminal	M5	2.5 Nm (1.84 lbf ft)
-------------------------	----	-------------------------

i Info
 Both poles of the contact disk A must be mounted between screw 1 and cable lug 2 with the claws facing down.

- Slide positive terminal cover 3 over the positive terminal.
- Position the negative cable and mount and tighten the screw.

Guideline

Screw, battery terminal	M5	2.5 Nm (1.84 lbf ft)
-------------------------	----	-------------------------

Battery (YTX5L-BS) (p. 100)

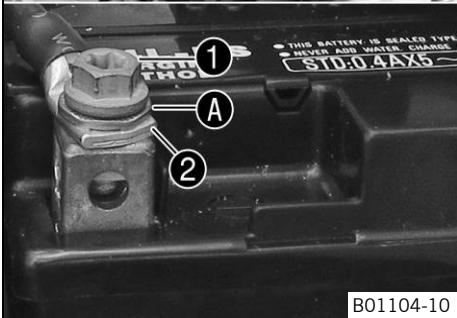

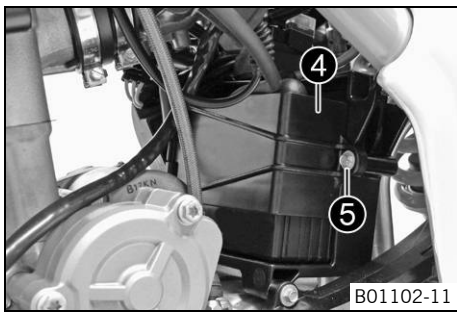

- Position the battery in the battery compartment.
- Attach fixing flap ④.
- Mount and tighten screw ⑤.

15.3 Recharging the battery ↩

Warning
Risk of injury Battery acid and battery gases cause serious chemical burns.

- Keep batteries out of the reach of children.
- Wear suitable protective clothing and goggles.
- Avoid contact with battery acid and battery gases.
- Keep sparks and open flames away from the battery. Only charge in well-ventilated rooms.
- In the event of skin contact, rinse with large amounts of water. If battery acid gets in the eyes, rinse with water for at least 15 minutes and contact a physician.

Warning
Environmental hazard The battery contains elements that are harmful to the environment.

- Do not discard batteries with the household waste. Dispose of faulty batteries in an environmentally compatible manner. Give the battery to your authorized KTM dealer or dispose of it at a collection point for used batteries.

Warning
Environmental hazard Hazardous substances cause environmental damage.

- Oil, grease, filters, fuel, cleaners, brake fluid, etc., should be disposed of as stipulated in applicable regulations.

i Info
 Even when there is no load on the battery, it discharges steadily.
 The charge state and the type of charge are very important for the service life of the battery.
 Rapid recharging with a high charging current shortens the battery's service life.
 If the charging current, charging voltage, and charging time are exceeded, electrolyte escapes through the safety valves. This reduces the battery capacity.
 If the battery is depleted from starting the vehicle repeatedly, the battery must be charged immediately.
 If the battery is left in a discharged state for an extended period, it will become over-discharged and sulfate, destroying the battery.
 The battery is maintenance-free, i.e., the acid level does not have to be checked.

Preparatory work
 - Remove the battery. ↩ (p. 74)

Main work
 - Connect the battery charger to the battery. Switch on the battery charger.

Battery charger (58429074000)

You can also use the battery charger to test the rest potential and starting ability of the battery, and to test the alternator. With this device, you cannot overcharge the battery.

i Info
 Never remove lid ①.
 Charge the battery with a maximum of 10% of the capacity specified on the battery housing ②.



- Switch off the battery charger after charging. Disconnect the battery charger from the battery.

Guideline

The charging current, charging voltage, and charging time must not be exceeded.	
Charge the battery regularly when the motorcycle is not in use	3 months

Finishing work

- Install the battery. ↘ (☞ p. 74)

15.4 Changing the main fuse

Warning **Fire hazard** The electrical system can be overloaded if the wrong fuses are used.

- Use only fuses with the prescribed amperage. Never by-pass or repair fuses.

Info The main fuse protects all power consumers of the vehicle. It is located behind the battery.

Preparatory work

- Switch off all power consumers and switch off the engine.
- Raise the motorcycle with the lift stand. (☞ p. 37)
- Fold the seat up. (☞ p. 45)
- Remove the shock absorber. ↘ (☞ p. 44)

Main work

- Remove protection caps ❶.

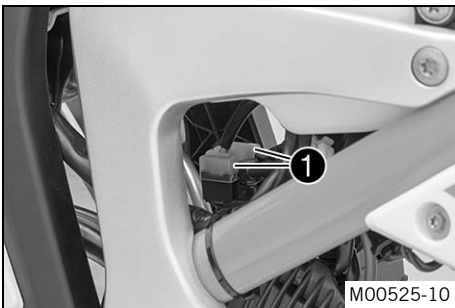

- Remove the faulty main fuse ❷.

Info A defective fuse is indicated by a burned-out fuse wire **A**. A reserve fuse ❸ is located in the starter relay.

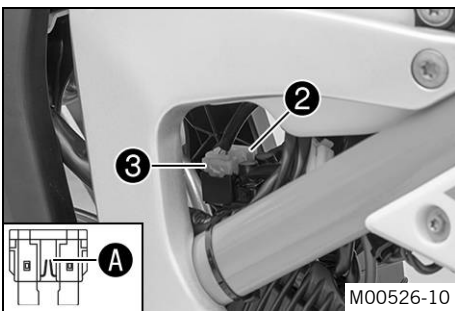

- Install a new main fuse.

Fuse (58011109120) (☞ p. 100)

- Check that the electrical equipment is functioning properly.

Tip Insert the spare fuse so that it is available if needed.

- Mount the protection caps.

Finishing work

- Install the shock absorber. ↘ (☞ p. 44)
- Lock the seat. (☞ p. 45)
- Remove the motorcycle from the lift stand. (☞ p. 37)

15.5 Changing the fuses of individual power consumers



Info

The fuse box containing the fuses of individual power consumers is located under the seat.

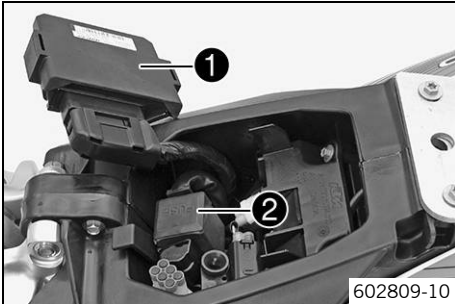

602809-10

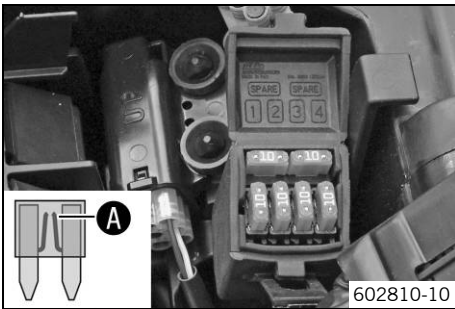

602810-10

Preparatory work

- Switch off all power consumers and switch off the engine.
- Fold the seat up. (☛ p. 45)

Main work

- Pull the EFI control unit **1** from the holder and hang it to one side.
- Open fuse box cover **2**.

- Remove the defective fuse.

Guideline

Fuse 1 - 10 A - EFI control unit, lambda sensor, injection valve
Fuse 2 - 10 A - fuel pump
Fuse 3 - 10 A - high beam, low beam, parking light, tail light, license plate lamp
Fuse 4 - 10 A - horn, brake light, turn signal, radiator fan, speedometer
Fuses res - 10 A - spare fuses



Info

A defective fuse is indicated by a burned-out fuse wire **A**.



Warning

Fire hazard The electrical system can be overloaded if the wrong fuses are used.

- Use only fuses with the prescribed amperage. Never by-pass or repair fuses.

- Use spare fuses with the correct rating only.

Fuse (75011088010) (☛ p. 100)



Tip

Replace the spare fuse in the fuse box so that it is available if needed.

- Check that the power consumer is functioning properly.
- Close the fuse box cover.
- Position the EFI control unit.

Finishing work

- Lock the seat. (☛ p. 45)

15.6 Removing the headlight mask with the headlight



- Switch off all power consumers.
- Detach the brake line and wiring harness ①.
- Release rubber band ②. Slide the headlight mask up and swing it forward.

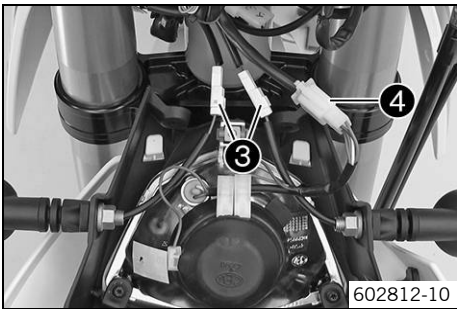

- Disconnect the plug-in connectors ③ for the turn signals and ④ for the headlight.

15.7 Refitting the headlight mask with the headlight

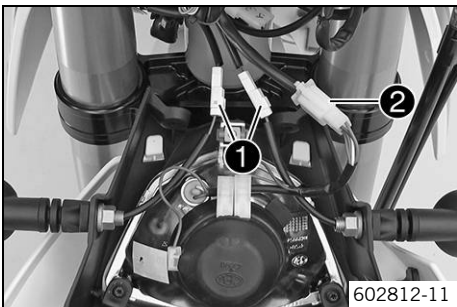

Main work

- Connect the plug-in connectors ① for the turn signals and ② for the headlight.

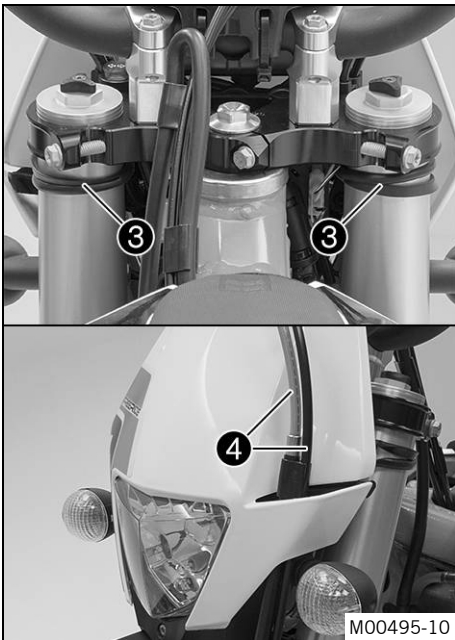

- Position the headlight mask and fix it with the rubber band ③.
- ✓ The holding lugs engage.
- Position the brake line and wiring harness ④.

Finishing work

- Check the headlight setting. (☛ p. 80)

15.8 Changing the headlight bulb

Note

Damage to reflector Reduced brightness.

- Grease on the lamp will evaporate due to the heat and be deposited on the reflector. Clean the lamp and keep it free of grease before mounting.

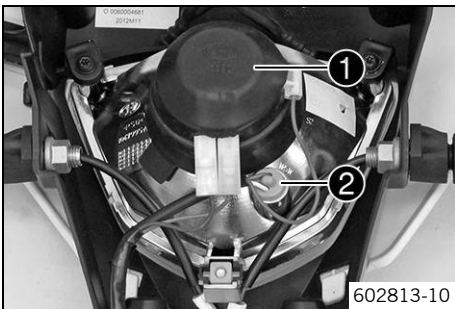

Preparatory work

- Remove the headlight mask with the headlight. (☛ p. 78)

Main work

- Turn rubber cap ① together with the underlying bulb socket counterclockwise all the way and remove it.
- Pull bulb socket ② of the parking light out of the reflector.

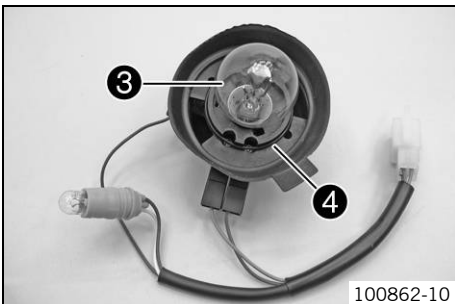

- Press headlight bulb ③ lightly into the bulb socket, turn it counterclockwise, and pull it out.
- Insert the new headlight bulb.

Headlight (S2/socket BA20d) (☛ p. 100)

- Insert the rubber cap with the bulb socket into the reflector and turn it clockwise all the way.



Info

Ensure that O-ring ④ is seated properly.

- Insert the bulb socket of the parking light into the reflector.

Finishing work

- Refit the headlight mask with the headlight. (☛ p. 78)
- Check the headlight setting. (☛ p. 80)

15.9 Changing the turn signal bulb

Note

Damage to reflector Reduced brightness.

- Grease on the lamp will evaporate due to the heat and be deposited on the reflector. Clean the lamp and keep it free of grease before mounting.

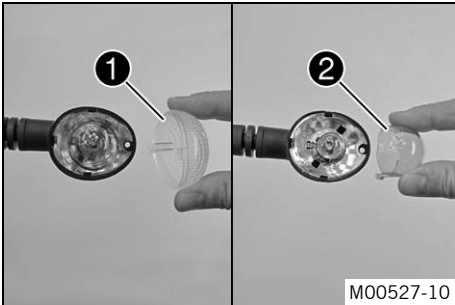

Main work

- Remove the screw on the rear of the turn signal housing.
- Carefully remove diffuser ①.
- Lightly squeeze together the orange cap ② in the area of the holding lugs and take it off.
- Press the turn signal bulb carefully into the socket, turn it counterclockwise by about 30°, and take it out of the socket.

i Info

Do not touch the reflector with your fingers, and keep it free from grease.

- Press the new turn signal bulb carefully into the socket and turn it clockwise until it stops.

Turn signal (R10W/socket BA15s) (☛ p. 100)

- Mount the orange cap.
- Position the diffuser.
- Insert the screw and first turn it counterclockwise until it engages in the thread. Tighten the screw slightly.

Finishing work

- Check that the turn signal system is functioning properly.

15.10 Checking the headlight setting

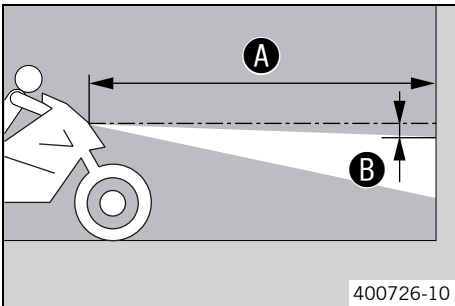

- Position the vehicle upright on a horizontal surface in front of a light wall and make a mark at the height of the center of the low beam headlight.

- Make another mark at a distance B under the first mark.

Guideline

Distance B	5 cm (2 in)
------------	-------------

- Position the vehicle vertically a distance A away from the wall.

Guideline

Distance A	5 m (16 ft)
------------	-------------

- The rider now sits down on the motorcycle.
- Switch on the low beam.
- Check the headlight setting.

The boundary between light and dark must be exactly on the lower mark for a motorcycle with driver.

- » If the boundary between light and dark does not meet specifications:
 - Adjust the headlight range. (☛ p. 80)

15.11 Adjusting the headlight range

Preparatory work

- Check the headlight setting. (☛ p. 80)



Main work

- Adjust the beam distance of the headlight by turning screw 1.

Guideline

For a motorcycle with rider, the light/dark boundary must be exactly on the lower mark (the mark is created in: Checking the headlight setting).

Info

Turn clockwise to increase the headlight range, turn counterclockwise to reduce the headlight range.
A change in weight on the vehicle may require a correction of the headlight range.

15.12 Changing the speedometer battery

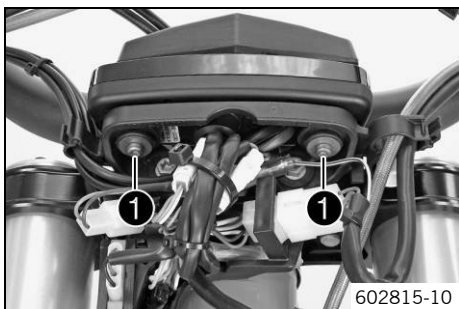

Preparatory work

- Remove the headlight mask with the headlight. (☛ p. 78)

Main work

- Remove screws 1.
- Pull the speedometer upward out of the holder.

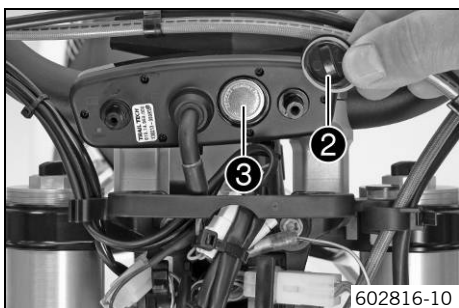

- Using a coin, turn protection cap 2 all the way counterclockwise and remove it.
- Remove speedometer battery 3.
- Insert the new battery with the label facing outward.

Speedometer battery (CR 2032) (☛ p. 100)

- Check the O-ring of the protection cap for correct seating.

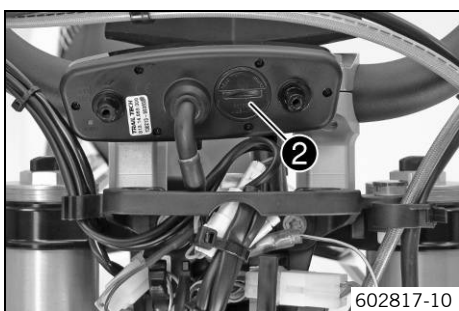

- Position protection cap 2 and turn all the way clockwise using a coin.
- Press any button on the speedometer.
- ✓ The speedometer is activated.
- Position the speedometer in the holder.
- Mount and tighten the screws with washers.

Finishing work

- Refit the headlight mask with the headlight. (☛ p. 78)
- Check the headlight setting. (☛ p. 80)
- Set the speedometer. (☛ p. 18)

16.1 Cooling system

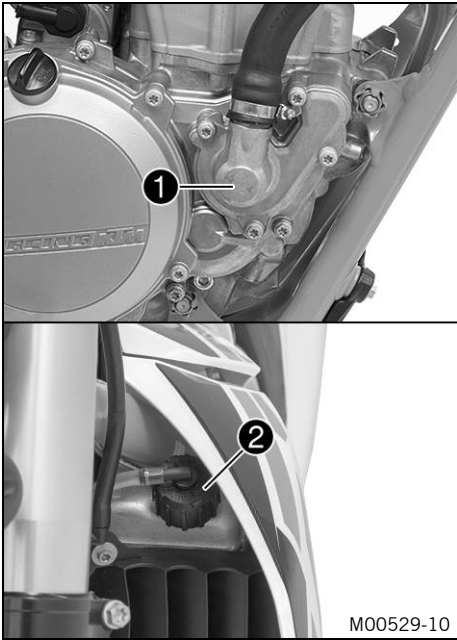

Water pump ① in the engine circulates the coolant. The pressure resulting from the warming of the cooling system is regulated by a valve in radiator cap ②. This ensures that operating the vehicle at the specified coolant temperature will not result in a risk of malfunctions.

120 °C (248 °F)

Cooling is effected by the air stream. The lower the speed, the less the cooling effect. Dirty cooling fins also reduce the cooling effect. The radiator fan provides extra cooling. It is controlled by a thermostitch.

16.2 Checking the antifreeze and coolant level

Warning
Danger of scalding During motorcycle operation, the coolant gets very hot and is under pressure.

- Do not remove the radiator cap, radiator hoses or other cooling system components when the engine is hot. Allow the engine and cooling system to cool down. In case of scalding, rinse immediately with lukewarm water.

Warning
Danger of poisoning Coolant is poisonous and a health hazard.

- Coolant must not come into contact with the skin, eyes, or clothing. If contact occurs with the eyes, rinse with water immediately and contact a physician. Immediately clean contaminated areas on the skin with soap and water. If coolant is swallowed, contact a physician immediately. Change clothing that is contaminated with coolant. Keep coolant out of reach of children.

Condition
 The engine is cold.

- Stand the motorcycle upright on a horizontal surface.
- Remove the radiator cap.
- Check the coolant antifreeze.

-25... -45 °C (-13... -49 °F)

- » If the antifreeze of the coolant does not meet specifications:
 - Correct the coolant antifreeze.

- Check the coolant level in the radiator.

Coolant level ① above radiator fins.	10 mm (0.39 in)
--------------------------------------	-----------------

- » If the coolant level does not meet specifications:
 - Correct the coolant level.

Coolant (☛ p. 103)

- Mount the radiator cap.

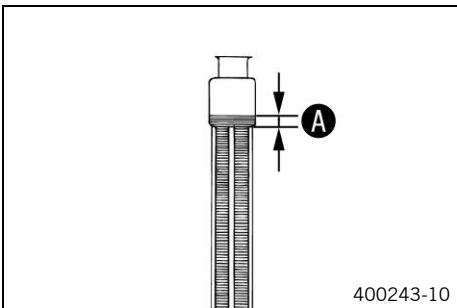

16.3 Checking the coolant level

Warning
Danger of scalding During motorcycle operation, the coolant gets very hot and is under pressure.

- Do not remove the radiator cap, radiator hoses or other cooling system components when the engine is hot. Allow the engine and cooling system to cool down. In case of scalding, rinse immediately with lukewarm water.

Warning
Danger of poisoning Coolant is poisonous and a health hazard.

- Coolant must not come into contact with the skin, eyes, or clothing. If contact occurs with the eyes, rinse with water immediately and contact a physician. Immediately clean contaminated areas on the skin with soap and water. If coolant is swallowed, contact a physician immediately. Change clothing that is contaminated with coolant. Keep coolant out of reach of children.

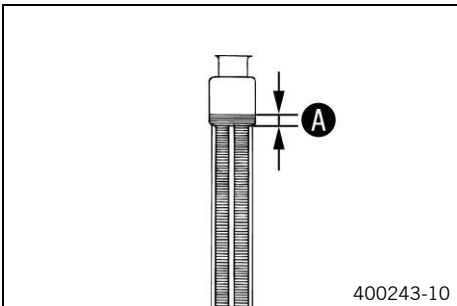

Condition

The engine is cold.

- Stand the motorcycle upright on a horizontal surface.
- Remove the radiator cap.
- Check the coolant level in the radiator.

Coolant level A above radiator fins.	10 mm (0.39 in)
---	-----------------

- » If the coolant level does not meet specifications:
 - Correct the coolant level.

Coolant (☛ p. 103)

- Mount the radiator cap.

16.4 Draining the coolant ☛

Warning
Danger of scalding During motorcycle operation, the coolant gets very hot and is under pressure.

- Do not remove the radiator cap, radiator hoses or other cooling system components when the engine is hot. Allow the engine and cooling system to cool down. In case of scalding, rinse immediately with lukewarm water.

Warning
Danger of poisoning Coolant is poisonous and a health hazard.

- Coolant must not come into contact with the skin, eyes, or clothing. If contact occurs with the eyes, rinse with water immediately and contact a physician. Immediately clean contaminated areas on the skin with soap and water. If coolant is swallowed, contact a physician immediately. Change clothing that is contaminated with coolant. Keep coolant out of reach of children.

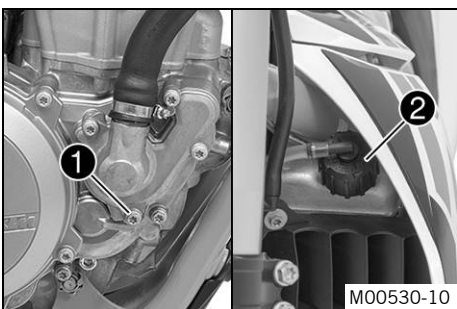

Condition

The engine is cold.

- Stand the motorcycle upright.
- Place a suitable container under the water pump cover.
- Remove screw **1**. Take off radiator cap **2**.
- Completely drain the coolant.
- Mount screw **1** with a new seal ring and tighten it.

Guideline

Screw, water pump cover	M6	10 Nm (7.4 lbf ft)
-------------------------	----	--------------------

16.5 Refilling coolant

- Warning**
Danger of poisoning Coolant is poisonous and a health hazard.
- Coolant must not come into contact with the skin, eyes, or clothing. If contact occurs with the eyes, rinse with water immediately and contact a physician. Immediately clean contaminated areas on the skin with soap and water. If coolant is swallowed, contact a physician immediately. Change clothing that is contaminated with coolant. Keep coolant out of reach of children.

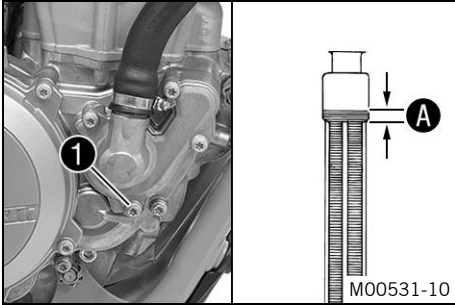

Main work

- Make sure that screw ① is tightened.
- Stand the motorcycle upright.
- Pour coolant in up to measurement A above the radiator fins.

Guideline

10 mm (0.39 in)

Coolant	0.7 l (0.7 qt.)	Coolant (☛ p. 103)
---------	-----------------	--------------------

- Mount the radiator cap.

Finishing work

- Take a short test ride.
- Check the coolant level. (☛ p. 83)

17.1 Checking the play in the throttle cable

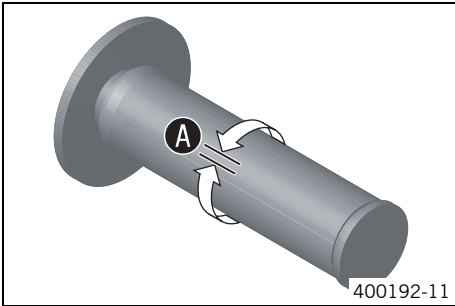

- Check the throttle grip for smooth operation.
- Move the handlebar to the straight-ahead position. Turn the throttle grip back and forth slightly and determine the play in throttle cable **A**.

Throttle cable play	3... 5 mm (0.12... 0.2 in)
---------------------	----------------------------

- » If the throttle cable play does not meet specifications:
 - Adjust the play in the throttle cable. 🛠️ (☞ p. 85)



Danger

Danger of poisoning Exhaust gases are toxic and inhaling them may result in unconsciousness and/or death.

- When running the engine, always make sure there is sufficient ventilation, and do not start or run the engine in an enclosed space without an effective exhaust extraction system.

- Start the engine and let it run idle. Move the handlebar to and fro over the entire steering range.

The idle speed must not change.

- » If the idle speed changes:
 - Adjust the play in the throttle cable. 🛠️ (☞ p. 85)

17.2 Adjusting the play in the throttle cable 🛠️

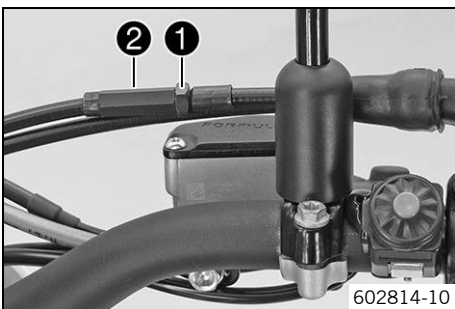

Preparatory work

- Fold the seat up. (☞ p. 45)
- Remove the fuel tank. 🛠️ (☞ p. 50)
- Check the throttle cable routing. (☞ p. 57)

Main work

- Move the handlebar to the straight-ahead position.
- Loosen nut **1**. Turn adjusting screw **2** so that there is play in the throttle cable at the throttle grip.

Guideline

Throttle cable play	3... 5 mm (0.12... 0.2 in)
---------------------	----------------------------

- Tighten nut **1**.
- Check the throttle grip for smooth operation.

Finishing work

- Install the fuel tank. 🛠️ (☞ p. 51)
- Lock the seat. (☞ p. 45)

17.3 Adjusting the idle speed ↘

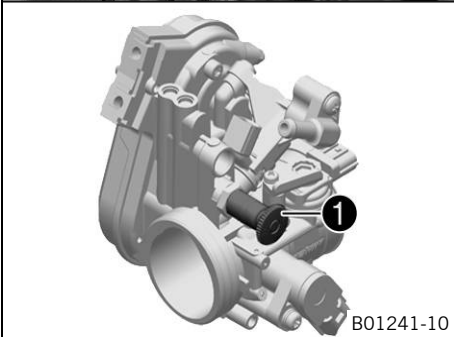
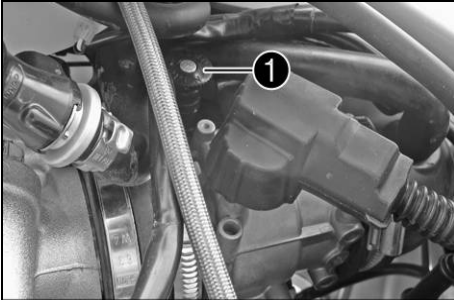

- Run the engine warm and push the idle speed adjusting screw ❶ all the way in.
- Set the desired idle speed by turning the idle speed adjusting screw.

Guideline

Idle speed	1,800... 1,900 rpm
------------	--------------------



Info

Turn counterclockwise to increase the idle speed.
Turn clockwise to decrease the idle speed.

17.4 Checking the basic position of the shift lever

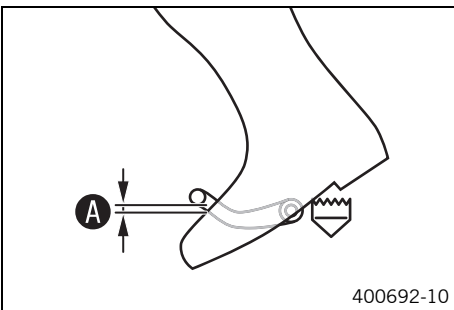

- Sit on the vehicle in the riding position and determine distance ❶ between the upper edge of your boot and the shift lever.

Distance between shift lever and upper edge of boot	10... 20 mm (0.39... 0.79 in)
---	-------------------------------

- » If the distance does not meet specifications:
 - Adjust the basic position of the shift lever. ↘ (p. 86)

17.5 Adjusting the basic position of the shift lever ↘

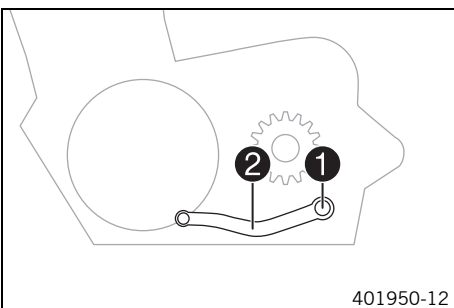

- Remove screw ❶ and take off shift lever ❷.

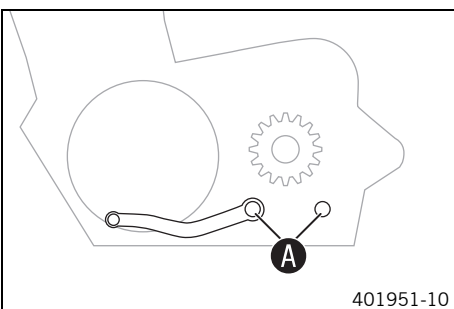

- Clean gear teeth ❶ of the shift lever and shift shaft.
- Mount the shift lever on the shift shaft in the required position and engage the gearing.



Info

The range of adjustment is limited.
The shift lever must not come into contact with any other vehicle components during the shift procedure.

- Mount and tighten screw.

Guideline

Screw, shift lever	M6	14 Nm (10.3 lbf ft)	Loctite® 243™
--------------------	----	------------------------	---------------

18.1 Changing the fuel screen 

- Danger**
Fire hazard Fuel is highly flammable.
- Never refuel the vehicle near open flames or burning cigarettes, and always switch off the engine first. Be careful that no fuel is spilt, especially on hot vehicle components. Clean up spilt fuel immediately.
 - The fuel in the fuel tank expands when warm and may emerge if overfilled. Follow the instructions on refueling.

- Warning**
Danger of poisoning Fuel is poisonous and a health hazard.
- Fuel must not come into contact with the skin, eyes, or clothing. Do not breathe in the fuel vapors. If contact occurs with the eyes, rinse with water immediately and contact a physician. Immediately clean contaminated areas on the skin with soap and water. If fuel is swallowed, contact a physician immediately. Change clothing that is contaminated with fuel.

- Warning**
Environmental hazard Improper handling of fuel is a danger to the environment.
- Do not allow fuel to get into the ground water, the ground, or the sewage system.

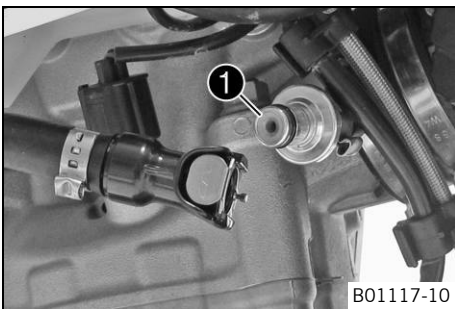
**Main work**

- Thoroughly clean the plug-in connection of the fuel line using compressed air.

i Info
 Under no circumstances should dirt enter into the fuel line. Dirt in the fuel line clogs the injection valve.

- Disconnect the plug-in connection of the fuel line.
- Pull fuel screen **1** out of the connecting piece.
- Slide a new fuel screen into the connecting piece.
- Lubricate the O-ring and connect plug-in connection of the fuel line.

Finishing work

Danger
Danger of poisoning Exhaust gases are toxic and inhaling them may result in unconsciousness and/or death.

- When running the engine, always make sure there is sufficient ventilation, and do not start or run the engine in an enclosed space without an effective exhaust extraction system.

- Start the engine and check the response.

18.2 Checking the engine oil level

i Info
 The engine oil level can be checked when the engine is cold or warm.

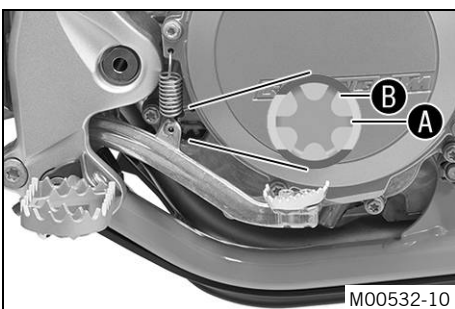
**Preparatory work**

- Stand the motorcycle upright on a horizontal surface.

Condition

The engine is cold.

- Check the engine oil level.

The engine oil level is up to the middle **A** of the level viewer.

- » If the engine oil is not up to the middle of the level viewer:
 - Add engine oil. (🔧 p. 90)

Condition

The engine is at operating temperature.

- Check the engine oil level.

i Info
 After switching off the engine, wait one minute before checking the level.

The engine oil is at a level between the middle **A** and upper edge **B** of the level viewer.

- » If the engine oil is not up to the middle **A** of the level viewer:
 - Add engine oil. (🔧 p. 90)

18.3 Changing the engine oil and oil filter, cleaning the oil screen 🛠️

Warning

Danger of scalding Engine oil and gear oil get very hot when the motorcycle is ridden.

- Wear appropriate protective clothing and safety gloves. In case of burns, rinse immediately with lukewarm water.

Warning

Environmental hazard Hazardous substances cause environmental damage.

- Oil, grease, filters, fuel, cleaners, brake fluid, etc., should be disposed of as stipulated in applicable regulations.

i Info

Drain the engine oil only when the engine is warm.

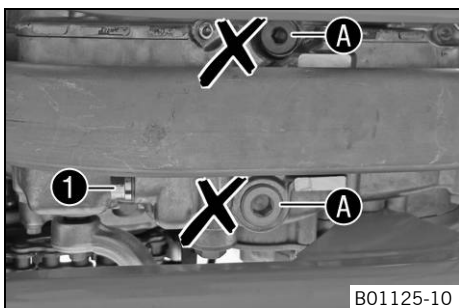

Preparatory work

- Park the motorcycle on a level surface.
- Remove the engine guard. (🔧 p. 60)

Main work

- Place a suitable container under the engine.
- Remove the oil drain plug **1** with the magnet and seal ring.

i Info

Do not remove screws **A** on both sides.

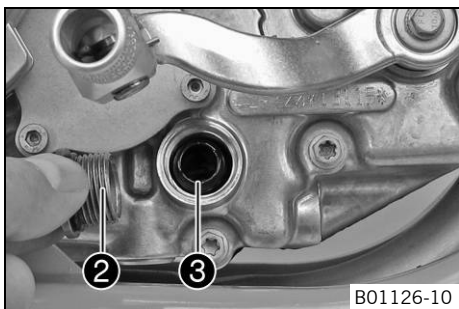

- Remove plug **2** with oil screen **3** and the O-rings.

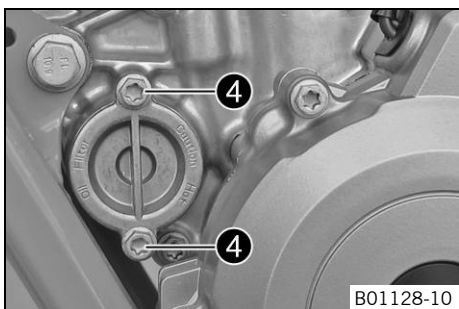

- Remove screws **4**. Remove the oil filter cover with the O-ring.

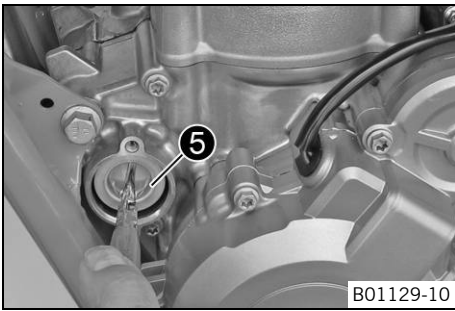

- Pull oil filter **5** out of the oil filter housing.

Circlip pliers reverse (51012011000)

- Completely drain the engine oil.
- Thoroughly clean the parts and sealing area.

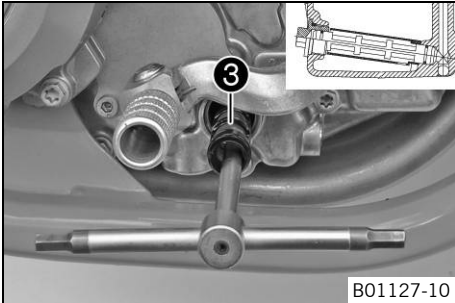

- Position oil screen **3** with the O-rings on a pin wrench.
- Position the pin wrench through the drilled hole of the screw plug in the opposite section of the engine case.
- Push the oil screen all the way into the engine case.

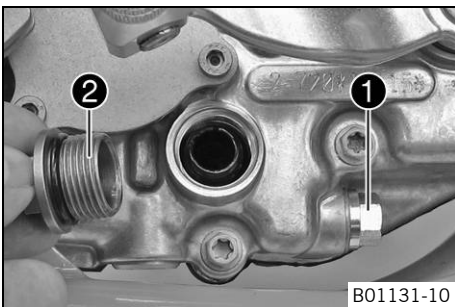

- Mount and tighten screw plug **2** with the O-ring.

Guideline

Screw plug, oil screen	M20x1.5	15 Nm (11.1 lbf ft)
------------------------	---------	------------------------

- Mount and tighten the oil drain plug **1** with the magnet and a new seal ring.

Guideline

Oil drain plug with magnet	M12x1.5	20 Nm (14.8 lbf ft)
----------------------------	---------	------------------------

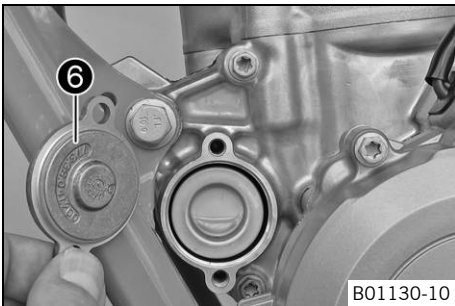

- Lay the motorcycle on its side and fill the oil filter housing to about 1/3 full with engine oil.
- Insert the oil filter into the oil filter housing.
- Oil the O-ring of the oil filter cover and mount it with the oil filter cover **6**.
- Mount and tighten the screws.

Guideline

Screw, oil filter cover	M6	10 Nm (7.4 lbf ft)
-------------------------	----	--------------------

- Stand the motorcycle upright.

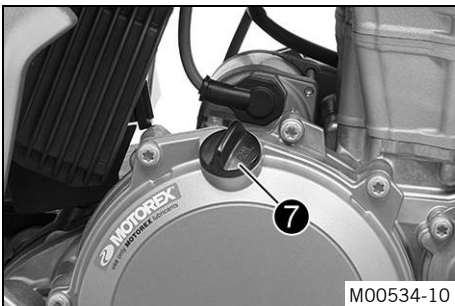

- Remove the oil filler plug **7** with the O-ring from the clutch cover and fill up with engine oil.

Engine oil	1.20 l (1.27 qt.)	Engine oil (SAE 10W/50) (☛ p. 103)	
		Alternative engine oil	Engine oil (SAE 10W/60) (00062010035) (☛ p. 103)



Info

Too little engine oil or poor-quality engine oil results in premature wear to the engine.

- Install and tighten the oil filler plug with the O-ring.



Danger

Danger of poisoning Exhaust gases are toxic and inhaling them may result in unconsciousness and/or death.

- When running the engine, always make sure there is sufficient ventilation, and do not start or run the engine in an enclosed space without an effective exhaust extraction system.

- Start the engine and check that it is oil-tight.

Finishing work

- Install the engine guard. (☞ p. 60)
- Check the engine oil level. (☞ p. 87)

18.4 Adding engine oil**i Info**

Too little engine oil or poor-quality engine oil results in premature wear to the engine.

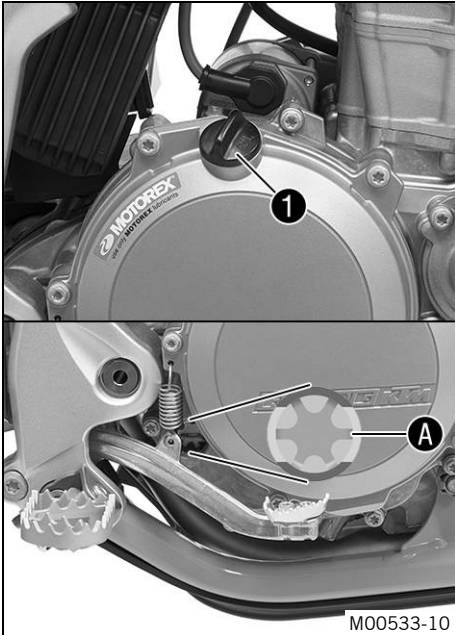

M00533-10

Main work

- Remove the oil filler plug ① with the O-ring from the clutch cover.
- Fill engine oil to the middle A of the level viewer.

Engine oil (SAE 10W/50) (☞ p. 103)

Engine oil (SAE 10W/60) (00062010035) (☞ p. 103)
--

i Info

In order to achieve optimal engine performance, it is not advisable to mix different engine oils.

We recommended changing the engine oil when necessary.

- Install and tighten the oil filler plug with the O-ring.

**Danger**

Danger of poisoning Exhaust gases are toxic and inhaling them may result in unconsciousness and/or death.

- When running the engine, always make sure there is sufficient ventilation, and do not start or run the engine in an enclosed space without an effective exhaust extraction system.

- Start the engine and check that it is oil-tight.

Finishing work

- Check the engine oil level. (☞ p. 87)

19.1 Cleaning the motorcycle

Note

Material damage Damage and destruction of components by high-pressure cleaning equipment.

- When cleaning the vehicle with a pressure cleaner, do not point the water jet directly onto electrical components, connectors, cables, bearings, etc. Maintain a minimum distance of 60 cm between the nozzle of the pressure cleaner and the component. Excessive pressure can cause malfunctions or destroy these parts.

Warning

Environmental hazard Hazardous substances cause environmental damage.

- Oil, grease, filters, fuel, cleaners, brake fluid, etc., should be disposed of as stipulated in applicable regulations.

Info

If you clean the motorcycle regularly, its value and appearance will be maintained over a long period. Avoid direct sunshine on the motorcycle during cleaning.

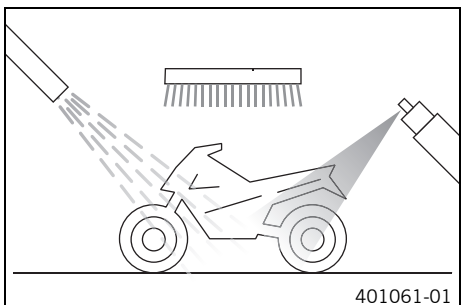

- Close off the exhaust system to keep water from entering.
- First remove coarse dirt particles with a gentle spray of water.
- Spray very dirty areas with a normal motorcycle cleaner and then clean with a paintbrush.

Motorcycle cleaner (☛ p. 105)

Info

Use warm water containing normal motorcycle cleaner and a soft sponge. Never apply motorcycle cleaner to the dry vehicle; always rinse with water first.

- After rinsing the motorcycle with a gentle spray of water, allow it to dry thoroughly.
- Remove the plug from the exhaust system.

Warning

Danger of accidents Reduced braking efficiency due to a wet or dirty brake system.

- Clean or dry a dirty or wet brake system by riding and braking gently.

- After cleaning, ride a short distance until the engine reaches operating temperature.

Info

The heat produced causes water at inaccessible locations in the engine and the brake system to evaporate.

- After the motorcycle has cooled off, lubricate all moving parts and bearings.
- Clean the chain. (☛ p. 53)
- Treat bare metal parts (except for the brake discs and exhaust system) with anti-corrosion materials.

Preserving materials for paints, metal and rubber (☛ p. 105)

- Treat all plastic parts and powder-coated parts with a mild cleaning and care product.

Special cleaner for glossy and matte paint finishes, metal and plastic surfaces (☛ p. 105)

- Oil the steering lock.

Universal oil spray (☛ p. 106)

19.2 Checks and maintenance steps for winter operation

- i Info**
 If the motorcycle is used in the winter, salt can be expected on the roads. Precautions need to be taken against road salt corrosion.
 If the vehicle was operated in road salt, clean it with cold water after riding. Warm water would enhance the corrosive effects of salt.

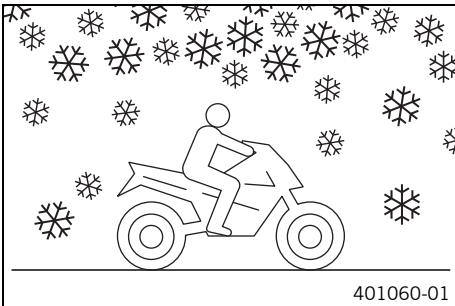

- Clean the motorcycle. (🔧 p. 91)
- Clean the brake system.

- i Info**
 After **EVERY** trip on salted roads, thoroughly wash the brake calipers and brake linings with cold water and dry carefully. This should be done after the parts are cooled down and while they are installed.
 After riding on salted roads, thoroughly wash the motorcycle with cold water and dry it well.

- Treat the engine, swingarm, and all other bright and zinc-plated parts (except for the brake discs) with a wax-based corrosion inhibitor.

- i Info**
 Corrosion inhibitor is not permitted to come in contact with the brake discs as this would greatly reduce the braking force.

- Clean the chain. (🔧 p. 53)

20.1 Storage



Warning

Danger of poisoning Fuel is poisonous and a health hazard.

- Fuel must not come into contact with the skin, eyes, or clothing. Do not breathe in the fuel vapors. If contact occurs with the eyes, rinse with water immediately and contact a physician. Immediately clean contaminated areas on the skin with soap and water. If fuel is swallowed, contact a physician immediately. Change clothing that is contaminated with fuel. Store fuel properly in a suitable canister and keep away from children.



Info

If you want to garage the motorcycle for a longer period, take the following steps. Before storing the motorcycle, check all parts for function and wear. If service, repairs or replacements are necessary, you should do this during the storage period (less workshop overload). In this way, you can avoid long workshop waiting times at the start of the new season.

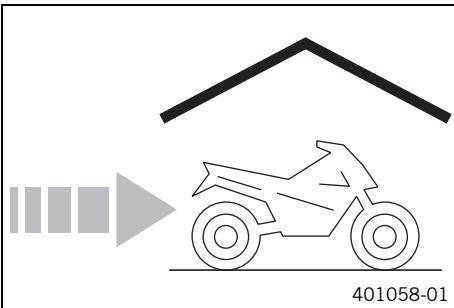

- When refueling for the last time before taking the motorcycle out of service, add fuel additive.

Fuel additive (☞ p. 105)

- Refuel. (☞ p. 27)
- Clean the motorcycle. (☞ p. 91)
- Change the engine oil and oil filter, clean the oil screen. 🛠️ (☞ p. 88)
- Check the antifreeze and coolant level. (☞ p. 82)
- Check the tire air pressure. (☞ p. 73)
- Remove the battery. 🛠️ (☞ p. 74)
- Recharge the battery. 🛠️ (☞ p. 75)

Guideline

Storage temperature of battery without direct sunlight	0... 35 °C (32... 95 °F)
--	--------------------------

- Store the vehicle in a dry location that is not subject to large fluctuations in temperature.



Info

KTM recommends raising the motorcycle.

- Raise the motorcycle with the lift stand. (☞ p. 37)
- Cover the motorcycle with a porous sheet or blanket. Do not use non-porous materials since they prevent humidity from escaping, thus causing corrosion.



Info

Avoid running the engine for a short time only. Since the engine cannot warm up properly, the water vapor produced during combustion condenses and causes valves and exhaust system to rust.



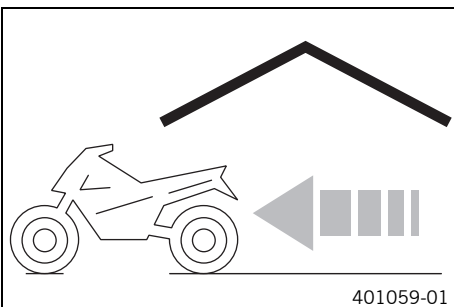







20.2 Preparing for use after storage



- Remove the motorcycle from the lift stand. (☞ p. 37)
- Install the battery. 🛠️ (☞ p. 74)
- Perform checks and maintenance work when preparing the vehicle for use. (☞ p. 24)
- Take a test ride.

Faults	Possible cause	Action
The engine cannot be cranked (electric starter)	Operating error	– Carry out the start procedure. (☞ p. 24)
	Battery is discharged	– Recharge the battery. 🛠️ (☞ p. 75) – Check the charging voltage. 🛠️ – Check the quiescent current. 🛠️ – Check the stator winding of the alternator. 🛠️
	Main fuse blown	– Change the main fuse. (☞ p. 76)
	Starter relay defective	– Check the starter relay. 🛠️
	Starter motor defective	– Check the starter motor. 🛠️
Engine turns but does not start	Operating error	– Carry out the start procedure. (☞ p. 24)
	The plug-in connection of the fuel hose connection is not connected	– Connect the plug-in connection of the fuel line.
	Fuse 1 blown	– Change the fuses of individual power consumers. (☞ p. 77)
	Fuse 2 blown	– Change the fuses of individual power consumers. (☞ p. 77)
	Idle speed is not set correctly	– Adjust the idle speed. 🛠️ (☞ p. 86)
	Spark plug oily or wet	– Clean and dry the spark plug, or change it if necessary.
	Electrode distance (plug gap) of spark plug too wide	– Adjust the plug gap. Guideline Spark plug electrode gap 1.0 mm (0.039 in)
	Short circuit cable in wiring harness frayed, kill switch defective	– Check the wiring harness. (visual check) – Check the electrical system.
Defect in fuel injection system	– Read out the fault memory using the KTM diagnostics tool. 🛠️	
Engine does not speed up	Defect in fuel injection system – Read out the fault memory using the KTM diagnostics tool. 🛠️	
Engine has too little power	Air filter is very dirty	– Clean the air filter and air filter housing. 🛠️ (☞ p. 48)
	Fuel filter is very dirty	– Change the fuel filter. 🛠️
	Fuel screen is very dirty	– Change the fuel screen. 🛠️ (☞ p. 87)
	Defect in fuel injection system	– Read out the fault memory using the KTM diagnostics tool. 🛠️
	Exhaust system leaky, deformed or too little glass fiber yarn filling in main silencer	– Check exhaust system for damage. – Change the glass fiber yarn filling of the main silencer. 🛠️ (☞ p. 50)
Valve clearance too little	– Adjust the valve clearance. 🛠️	
Engine dies during the trip	Lack of fuel	– Refuel. (☞ p. 27)
	Fuse 1 blown	– Change the fuses of individual power consumers. (☞ p. 77)
	Fuse 2 blown	– Change the fuses of individual power consumers. (☞ p. 77)
Engine overheats	Too little coolant in cooling system	– Check the cooling system for leaks. – Check the coolant level. (☞ p. 83)
	Too little air stream	– Switch off the engine when standing.
	Radiator fins very dirty	– Clean the radiator fins.
	Foam formation in cooling system	– Drain the coolant. 🛠️ (☞ p. 83) – Refill the coolant. 🛠️ (☞ p. 84)
	Bent radiator hose	– Change the radiator hose. 🛠️
	Defect in radiator fan system	– Check fuse 4. – Check the radiator fan. 🛠️

Faults	Possible cause	Action
FI warning lamp (MIL) lights up/flashes	Defect in fuel injection system	<ul style="list-style-type: none"> – Stop the motorcycle and identify the faulty part using the blink code. <hr/> <p>i Info See blink code</p> <hr/> <ul style="list-style-type: none"> – Check the cabling for damage and the connectors for corrosion and damage. – Read out the fault memory using the KTM diagnostics tool. 🛠️
High oil consumption	Engine vent hose bent	– Route the vent hose without bends or change it if necessary.
	Engine oil level too high	– Check the engine oil level. (🔧 p. 87)
	Engine oil too thin (low viscosity)	– Change the engine oil and oil filter, clean the oil screen. 🛠️ (🔧 p. 88)
	Piston and cylinder worn	– Measure the piston/cylinder mounting clearance. 🛠️
Battery is discharged	Battery is not being charged by alternator	<ul style="list-style-type: none"> – Check the charging voltage. 🛠️ – Check the stator winding of the alternator. 🛠️
	Unwanted power consumer	– Check the quiescent current. 🛠️
Speedometer values deleted (time, stop watch, lap times)	The battery in the speedometer is discharged	– Change the speedometer battery. (🔧 p. 81)
The high beam, low beam, parking light, tail light, and license plate lamp are not working	Fuse 3 blown	– Change the fuses of individual power consumers. (🔧 p. 77)
The speedometer, horn, brake light, turn signal, and radiator fan are not functional	Fuse 4 blown	– Change the fuses of individual power consumers. (🔧 p. 77)

Blink code FI warning lamp (MIL)	 45 FI warning lamp (MIL) flashes 4x long, 5x short
Error level condition	Lambda sensor heater cylinder 1, sensor 1 - short circuit to ground or open circuit Lambda sensor heater cylinder 1, sensor 1 - input signal too high
Blink code FI warning lamp (MIL)	 09 FI warning lamp (MIL) flashes 9x short
Error level condition	Manifold absolute pressure sensor cylinder 1 - input signal too low Manifold absolute pressure sensor cylinder 1 - input signal too high
Blink code FI warning lamp (MIL)	 13 FI warning lamp (MIL) flashes 1x long, 3x short
Error level condition	Intake air temperature sensor - input signal too low Intake air temperature sensor - input signal too high
Blink code FI warning lamp (MIL)	 12 FI warning lamp (MIL) flashes 1x long, 2x short
Error level condition	Engine coolant temperature sensor - input signal too low Engine coolant temperature sensor - input signal too high
Blink code FI warning lamp (MIL)	 06 FI warning lamp (MIL) flashes 6x short
Error level condition	Throttle position sensor circuit A - input signal too low Throttle position sensor circuit A - input signal too high
Blink code FI warning lamp (MIL)	 17 FI warning lamp (MIL) flashes 1x long, 7x short
Error level condition	Lambda sensor cylinder 1, sensor 1 - circuit fault
Blink code FI warning lamp (MIL)	 33 FI warning lamp (MIL) flashes 3x long, 3x short
Error level condition	Injector cylinder 1 - circuit fault
Blink code FI warning lamp (MIL)	 02 FI warning lamp (MIL) flashes 2x short
Error level condition	Crankshaft position sensor - circuit fault
Blink code FI warning lamp (MIL)	 37 FI warning lamp (MIL) flashes 3x long, 7x short
Error level condition	Ignition coil 1, cylinder 1 - circuit fault
Blink code FI warning lamp (MIL)	 41 FI warning lamp (MIL) flashes 4x long, 1x short
Error level condition	Fuel pump relay - short circuit to ground or open circuit Fuel pump control - input signal too low
Blink code FI warning lamp (MIL)	 15 FI warning lamp (MIL) flashes 1x long, 5x short
Error level condition	Rollover sensor (A/D type) - input signal too low Rollover sensor (A/D type) - input signal too high

23.1 Engine

Design	1-cylinder 4-stroke engine, water-cooled
Displacement	349.7 cm ³ (21.34 cu in)
Stroke	57.5 mm (2.264 in)
Bore	88 mm (3.46 in)
Compression ratio	12.3:1
Idle speed	1,800... 1,900 rpm
Control	DOHC, four valves controlled via cam lever, drive via timing chain
Valve diameter, intake	36.3 mm (1.429 in)
Valve diameter, exhaust	29.1 mm (1.146 in)
Valve clearance	
Intake at: 20 °C (68 °F)	0.10... 0.15 mm (0.0039... 0.0059 in)
Exhaust at: 20 °C (68 °F)	0.13... 0.18 mm (0.0051... 0.0071 in)
Crankshaft bearing	2 cylinder bearings
Conrod bearing	Slide bearing
Piston pin bearing	Not a bearing bush - DLC-plated piston pins
Pistons	Cast light alloy
Piston rings	1 compression ring, 1 oil scraper ring
Engine lubrication	Pressure circulation lubrication with two Eaton pumps
Primary transmission	24:73
Clutch	Multidisc clutch in oil bath/hydraulically activated
Transmission ratio	
1st gear	13:32
2nd gear	16:30
3rd gear	16:24
4th gear	23:28
5th gear	23:23
6th gear	26:20
Alternator	12 V, 196 W
Ignition	Contactless controlled fully electronic ignition with digital ignition adjustment
Spark plug	NGK LMAR9AI-10
Spark plug electrode gap	1.0 mm (0.039 in)
Cooling	Water cooling, permanent circulation of coolant by water pump
Starting aid	Electric starter

23.2 Engine tightening torques

Nozzle, crank chamber ventilation	M4	2 Nm (1.5 lbf ft)	Loctite® 243™
Oil nozzle for alternator cooling	M4	2 Nm (1.5 lbf ft)	Loctite® 243™
Oil nozzle for balancer shaft lubrication	M4	2 Nm (1.5 lbf ft)	Loctite® 243™
Oil nozzle for conrod bearing lubrication	M4	2 Nm (1.5 lbf ft)	Loctite® 243™
Screw, oil nozzle for piston cooling	M4	2 Nm (1.5 lbf ft)	Loctite® 243™
Locking screw for bearing	M5	6 Nm (4.4 lbf ft)	Loctite® 243™
Oil channel screw plug in alternator cover	M5	1.2 Nm (0.89 lbf ft)	Loctite® 648™
Oil nozzle for cam lever lubrication	M5	3 Nm (2.2 lbf ft)	Loctite® 243™
Oil nozzle for clutch lubrication	M5	6 Nm (4.4 lbf ft)	Loctite® 243™
Oil nozzle, piston cooling	M5	2 Nm (1.5 lbf ft)	Loctite® 243™
Screw, bearing bolt, oil pump idler gear	M5	6 Nm (4.4 lbf ft)	Loctite® 243™
Screw, crankshaft position sensor	M5	6 Nm (4.4 lbf ft)	Loctite® 243™

Screw, locking lever	M5	6 Nm (4.4 lbf ft)	Loctite® 243™
Screw, oil pump cover	M5	6 Nm (4.4 lbf ft)	Loctite® 243™
Screw, stator	M5	6 Nm (4.4 lbf ft)	Loctite® 243™
Nut, cylinder head	M6	10 Nm (7.4 lbf ft)	Lubricated with engine oil
Nut, water-pump wheel	M6	6 Nm (4.4 lbf ft)	Loctite® 243™
Screw, alternator cover	M6	6 Nm (4.4 lbf ft)	–
Screw, clutch cover	M6	10 Nm (7.4 lbf ft)	–
Screw, clutch slave cylinder	M6	10 Nm (7.4 lbf ft)	–
Screw, clutch spring	M6	10 Nm (7.4 lbf ft)	–
Screw, engine case	M6	10 Nm (7.4 lbf ft)	–
Screw, exhaust flange	M6	10 Nm (7.4 lbf ft)	Loctite® 243™
Screw, oil filter cover	M6	10 Nm (7.4 lbf ft)	–
Screw, shift drum locating	M6	10 Nm (7.4 lbf ft)	Loctite® 243™
Screw, shift lever	M6	14 Nm (10.3 lbf ft)	Loctite® 243™
Screw, starter motor	M6	10 Nm (7.4 lbf ft)	–
Screw, timing chain guide rail	M6	10 Nm (7.4 lbf ft)	Loctite® 243™
Screw, timing chain securing guide	M6	10 Nm (7.4 lbf ft)	Loctite® 243™
Screw, valve cover	M6	8 Nm (5.9 lbf ft)	–
Screw, water pump cover	M6	10 Nm (7.4 lbf ft)	–
Stud, cylinder head	M6	10 Nm (7.4 lbf ft)	–
Screw, camshaft bearing bridge	M7x1	14 Nm (10.3 lbf ft)	Lubricated with engine oil
Screw plug, crankshaft location	M8	10 Nm (7.4 lbf ft)	–
Screw, timing chain tensioning rail	M8	15 Nm (11.1 lbf ft)	Loctite® 243™
Screw, engine sprocket	M10	60 Nm (44.3 lbf ft)	Loctite® 2701™
Plug, oil channel	M10x1	15 Nm (11.1 lbf ft)	Loctite® 243™
Rotor screw	M10x1	70 Nm (51.6 lbf ft)	Thread, oiled with engine oil/cone degreased
Screw plug, cam lever axis	M10x1	10 Nm (7.4 lbf ft)	–
Screw, unlocking of timing chain tensioner	M10x1	10 Nm (7.4 lbf ft)	–
Spark plug	M10x1	10... 12 Nm (7.4... 8.9 lbf ft)	–
Nut, cylinder head	M10x1.25	Tightening sequence: Tighten diagonally. 1st tightening stage 10 Nm (7.4 lbf ft) 2nd tightening stage 30 Nm (22.1 lbf ft) 3rd tightening stage 50 Nm (36.9 lbf ft)	Thread, oiled with engine oil/cone greased
Stud, cylinder head	M10x1.25	20 Nm (14.8 lbf ft)	Loctite® 243™
Screw, camshaft drive sprocket	M12x1	70 Nm (51.6 lbf ft)	Loctite® 243™/cone degreased
Engine coolant temperature sensor	M12x1.5	12 Nm (8.9 lbf ft)	–
Oil drain plug with magnet	M12x1.5	20 Nm (14.8 lbf ft)	–
Plug, oil pressure regulator valve	M12x1.5	20 Nm (14.8 lbf ft)	–
Oil drain plug	M14x1.5	15 Nm (11.1 lbf ft)	–
Nut, inner clutch hub	M18x1.5	100 Nm (73.8 lbf ft)	Loctite® 243™
Nut, primary gear	M18LHx1.5	100 Nm (73.8 lbf ft)	Loctite® 243™
Screw plug, oil screen	M20x1.5	15 Nm (11.1 lbf ft)	–
Plug, timing chain tensioner	M24x1.5	25 Nm (18.4 lbf ft)	–
Screw, alternator cover	M24x1.5	18 Nm (13.3 lbf ft)	–

23.3 Capacities

23.3.1 Engine oil

Engine oil	1.20 l (1.27 qt.)	Engine oil (SAE 10W/50) (☛ p. 103)	
		Alternative engine oil	Engine oil (SAE 10W/60) (00062010035) (☛ p. 103)

23.3.2 Coolant

Coolant	0.7 l (0.7 qt.)	Coolant (☛ p. 103)
---------	-----------------	--------------------

23.3.3 Fuel

Total fuel tank capacity, approx.	5.5 l (1.45 US gal)	Super unleaded (ROZ 95/RON 95/PON 91) (☛ p. 104)
-----------------------------------	---------------------	--

Fuel reserve, approx.	1.5 l (1.6 qt.)
-----------------------	-----------------

23.4 Chassis

Frame	Perimeter, steel-aluminum composite frame	
fork	WP Suspension 4357 MXMA	
Suspension travel		
Front	250 mm (9.84 in)	
Rear	260 mm (10.24 in)	
Fork offset	20 mm (0.79 in)	
Shock absorber	WP Suspension 4618 PDS DCC	
Brake system		
Front	Disc brake with radially mounted four-piston brake caliper	
Rear	Disc brake with radially mounted dual-piston brake caliper	
Brake discs - diameter		
Front	260 mm (10.24 in)	
Rear	210 mm (8.27 in)	
Brake discs - wear limit		
Front	2.5 mm (0.098 in)	
Rear	3.5 mm (0.138 in)	
Tire air pressure, offroad		
Front	0.9 bar (13 psi)	
Rear	0.7 bar (10 psi)	
Tire air pressure, road		
Front	1.5 bar (22 psi)	
Rear	1.5 bar (22 psi)	
Secondary ratio	12:48	
Chain	5/8 x 1/4" X-ring	
Rear sprockets available	46, 48	
Steering head angle	67°	
Wheelbase	1,428±10 mm (56.22±0.39 in)	
Ground clearance, unloaded	325 mm (12.8 in)	
Seat height, unloaded	915 mm (36.02 in)	
Weight without fuel, approx.	101 kg (223 lb.)	
Maximum permissible front axle load	135 kg (298 lb.)	
Maximum permissible rear axle load	175 kg (386 lb.)	
Maximum permissible overall weight	280 kg (617 lb.)	

23.5 Electrical system

Battery	YTX5L-BS	Battery voltage: 12 V Nominal capacity: 4 Ah Maintenance-free
Speedometer battery	CR 2032	Battery voltage: 3 V
Fuse	75011088010	10 A
Fuse	58011109120	20 A
Headlight	S2/socket BA20d	12 V 35/35 W
Parking light	W5W/socket W2.1x9.5d	12 V 5 W
Indicator lamps	W2.3W/socket W2x4.6d	12 V 2.3 W
Turn signal	R10W/socket BA15s	12 V 10 W
Brake/tail light	LED	
License plate lamp	W5W/socket W2.1x9.5d	12 V 5 W

23.6 Tires

Front tires	Rear tires
2.75 - 21 M/C 45M TT MAXXIS TRIALMAXX	4.00 R 18 M/C 64M TL MAXXIS TRIALMAXX
Additional information is available in the Service section under: http://www.ktm.com	

23.7 Fork

Fork part number	05.18.7N.40
fork	WP Suspension 4357 MXMA
Compression damping	
Comfort	25 clicks
Standard	20 clicks
Sport	15 clicks
Rebound damping	
Comfort	25 clicks
Standard	20 clicks
Sport	15 clicks
Spring length with preload spacer(s)	
Weight of rider: 65... 75 kg (143... 165 lb.)	445 mm (17.52 in)
Weight of rider: 75... 85 kg (165... 187 lb.)	445 mm (17.52 in)
Weight of rider: 85... 95 kg (187... 209 lb.)	445 mm (17.52 in)
Spring rate	
Weight of rider: 65... 75 kg (143... 165 lb.)	4.4 N/mm (25.1 lb/in)
Weight of rider: 75... 85 kg (165... 187 lb.)	4.6 N/mm (26.3 lb/in)
Weight of rider: 85... 95 kg (187... 209 lb.)	4.8 N/mm (27.4 lb/in)
Fork length	835 mm (32.87 in)
Air chamber length	110 ⁺²⁰ / ₋₄₀ mm (4.33 ^{+0.79} / _{-1.57} in)
Fork oil per fork leg	410 ml (13.86 fl. oz.)
Fork oil (SAE 4) (48601166S1) (☛ p. 103)	

23.8 Shock absorber

Shock absorber part number	15.18.7N.40
Shock absorber	WP Suspension 4618 PDS DCC
Compression damping, low-speed	
Comfort	20 clicks
Standard	15 clicks
Sport	5 clicks
Compression damping, high-speed	
Comfort	2.5 turns
Standard	2 turns
Sport	1 turn
Rebound damping	
Comfort	20 clicks
Standard	15 clicks
Sport	10 clicks
Spring preload	
Comfort	12 mm (0.47 in)
Standard	12 mm (0.47 in)
Sport	12 mm (0.47 in)
Spring designation	
Weight of rider: 65... 75 kg (143... 165 lb.)	55/63/71-215
Weight of rider: 75... 85 kg (165... 187 lb.)	58/66/74-215
Weight of rider: 85... 95 kg (187... 209 lb.)	66-215
Spring length	215 mm (8.46 in)
Gas pressure	10 bar (145 psi)
Static sag	15 mm (0.59 in)
Riding sag	80 mm (3.15 in)
Fitted length	367 mm (14.45 in)
Shock absorber oil	Shock absorber fluid (SAE 2.5) (50180751S1) (☛ p. 104)

23.9 Chassis tightening torques

Screw for spoiler, front	EJOT PT® K60x30-Z	3 Nm (2.2 lbf ft)	–
Screw for spoiler, top	EJOT PT® K60x20AL	3 Nm (2.2 lbf ft)	–
Screw, pressure regulator	EJOT PT® K60x25-Z	3 Nm (2.2 lbf ft)	–
Spoke nipple	M4.5	6 Nm (4.4 lbf ft)	–
Screw, battery terminal	M5	2.5 Nm (1.84 lbf ft)	–
Screw, intake air temperature sensor	M5	2 Nm (1.5 lbf ft)	–
Screw, shock absorber adjusting ring	M5	5 Nm (3.7 lbf ft)	–
Screws on the main silencer	M5	7 Nm (5.2 lbf ft)	–
Nut, cable on starter motor	M6	4 Nm (3 lbf ft)	–
Remaining nuts, chassis	M6	10 Nm (7.4 lbf ft)	–
Remaining screws, chassis	M6	10 Nm (7.4 lbf ft)	–
Screw for spoiler attachment	M6	5 Nm (3.7 lbf ft)	–
Screw, ball joint of push rod on foot brake cylinder	M6	10 Nm (7.4 lbf ft)	Loctite® 243™
Screw, front brake disc	M6	14 Nm (10.3 lbf ft)	Loctite® 243™
Screw, radiator bracket	M6	7 Nm (5.2 lbf ft)	–
Screw, rear brake disc	M6	14 Nm (10.3 lbf ft)	Loctite® 243™
Screws, throttle grip	M6	3 Nm (2.2 lbf ft)	–
Fuel connection on fuel pump	M8	10 Nm (7.4 lbf ft)	–
Nut, foot brake lever stop	M8	20 Nm (14.8 lbf ft)	–

Nut, rear sprocket screw	M8	35 Nm (25.8 lbf ft)	Loctite® 2701™
Nut, rim lock	M8	10 Nm (7.4 lbf ft)	–
Remaining nuts, chassis	M8	25 Nm (18.4 lbf ft)	–
Remaining screws, chassis	M8	25 Nm (18.4 lbf ft)	–
Screw of rear brake caliper	M8	25 Nm (18.4 lbf ft)	Loctite® 243™
Screw, bottom triple clamp	M8	18 Nm (13.3 lbf ft)	–
Screw, chain sliding piece	M8	15 Nm (11.1 lbf ft)	–
Screw, engine brace on frame	M8	25 Nm (18.4 lbf ft)	Loctite® 243™
Screw, fork stub	M8	15 Nm (11.1 lbf ft)	–
Screw, front brake caliper	M8	25 Nm (18.4 lbf ft)	Loctite® 243™
Screw, fuel tank	M8	15 Nm (11.1 lbf ft)	Loctite® 243™
Screw, handlebar clamp	M8	20 Nm (14.8 lbf ft)	–
Screw, side stand attachment	M8	25 Nm (18.4 lbf ft)	Loctite® 2701™
Screw, subframe	M8	30 Nm (22.1 lbf ft)	Loctite® 243™
Screw, top steering stem	M8	17 Nm (12.5 lbf ft)	Loctite® 243™
Screw, top triple clamp	M8	22 Nm (16.2 lbf ft)	–
Engine bracket screw	M10	60 Nm (44.3 lbf ft)	–
Nut, fuel tank attachment	M10	10 Nm (7.4 lbf ft)	–
Remaining nuts, chassis	M10	45 Nm (33.2 lbf ft)	–
Remaining screws, chassis	M10	45 Nm (33.2 lbf ft)	–
Screw, battery compartment	M10	45 Nm (33.2 lbf ft)	–
Screw, cross bar	M10	45 Nm (33.2 lbf ft)	–
Screw, foot brake lever	M10	30 Nm (22.1 lbf ft)	Loctite® 243™
Screw, footrest bracket	M10	45 Nm (33.2 lbf ft)	Loctite® 243™
Screw, handlebar support	M10	40 Nm (29.5 lbf ft)	Loctite® 243™
Screw, upper subframe	M10	45 Nm (33.2 lbf ft)	Loctite® 243™
Nut, fuel pump fixation	M12	15 Nm (11.1 lbf ft)	–
Screw, bottom shock absorber	M12	80 Nm (59 lbf ft)	Loctite® 2701™
Screw, top shock absorber	M12	80 Nm (59 lbf ft)	Loctite® 2701™
Nut, swingarm pivot	M14x1.5	75 Nm (55.3 lbf ft)	–
Nut, rear wheel spindle	M20x1.5	80 Nm (59 lbf ft)	–
Screw, front wheel spindle	M20x1.5	35 Nm (25.8 lbf ft)	–
Screw, top steering head	M20x1.5	12 Nm (8.9 lbf ft)	–

Brake fluid DOT 4 / DOT 5.1

Standard/classification

- DOT

Guideline

- Use only brake fluid that complies with the specified standard (see specifications on the container) and that possesses the corresponding properties.

Recommended supplier

Castrol

- **RESPONSE BRAKE FLUID SUPER DOT 4**

Motorex®

- **Brake Fluid DOT 5.1**

Coolant

Guideline

- Only use high quality coolant with corrosion inhibitor for aluminum motors (even in countries with high temperatures). Using inferior antifreeze can result in corrosion and foaming.

Mixture ratio

Antifreeze protection: -25... -45 °C (-13... -49 °F)	anti-corrosion/antifreeze distilled water
--	---

Recommended supplier

Motorex®

- **COOLANT M3.0**

Engine oil (SAE 10W/50)

Standard/classification

- JASO T903 MA (☛ p. 107)
- SAE (☛ p. 107) (SAE 10W/50)

Guideline

- Use only engine oils that comply with the specified standards (see specifications on the container) and that possess the corresponding properties.

Synthetic engine oil

Recommended supplier

Motorex®

- **Cross Power 4T**

Engine oil (SAE 10W/60) (00062010035)

Standard/classification

- JASO T903 MA (☛ p. 107)
- SAE (☛ p. 107) (SAE 10W/60)
- KTM LC4 2007+

Guideline

- Use only engine oils that comply with the specified standards (see specifications on the container) and that possess the corresponding properties.

Synthetic engine oil

Recommended supplier

Motorex®

- **Cross Power 4T**

Fork oil (SAE 4) (48601166S1)

Standard/classification

- SAE (☛ p. 107) (SAE 4)

Guideline

- Use only oils that comply with the specified standards (see specifications on the container) and that possess the corresponding properties.

Shock absorber fluid (SAE 2.5) (50180751S1)

Standard/classification

- SAE (p. 107) (SAE 2.5)

Guideline

- Use only oils that comply with the specified standards (see specifications on the container) and that possess the corresponding properties.

Super unleaded (ROZ 95/RON 95/PON 91)

Standard/classification

- DIN EN 228 (ROZ 95/RON 95/PON 91)

Guideline

- Only use unleaded super fuel that matches or is equivalent to the specified fuel grade.
- Fuel with an ethanol content of up to 10 % (E10 fuel) is safe to use.



Info

Do **not** use fuel containing methanol (e. g. M15, M85, M100) or more than 10 % ethanol (e. g. E15, E25, E85, E100).

Air filter cleaner

Recommended supplier

Motorex®

- Racing Bio Dirt Remover

Chain cleaner

Recommended supplier

Motorex®

- Chain Clean

Fuel additive

Recommended supplier

Motorex®

- Fuel Stabilizer

High viscosity grease

Recommended supplier

SKF®

- LGHB 2

Long-life grease

Recommended supplier

Motorex®

- Bike Grease 2000

Motorcycle cleaner

Recommended supplier

Motorex®

- Moto Clean

Off-road chain spray

Recommended supplier

Motorex®

- Chainlube Offroad

Oil for foam air filter

Recommended supplier

Motorex®

- Racing Bio Liquid Power

Preserving materials for paints, metal and rubber

Recommended supplier

Motorex®

- Moto Protect

Rubber grip adhesive (00062030051)

Recommended supplier

KTM Motorrad AG

- GRIP GLUE

Special cleaner for glossy and matte paint finishes, metal and plastic surfaces

Recommended supplier

Motorex®

- Quick Cleaner

Universal oil spray

Recommended supplier

Motorex®

– Joker 440 Synthetic

JASO T903 MA

Different technical development directions required a new specification for 4-stroke motorcycles – the JASO T903 MA Standard. Earlier, engine oils from the automobile industry were used for 4-stroke motorcycles because there was no separate motorcycle specification. Whereas long service intervals are demanded for automobile engines, high performance at high engine speeds are in the foreground for motorcycle engines. In most motorcycles, the gearbox and the clutch are lubricated with the same oil as the engine. The JASO MA Standard meets these special requirements.

SAE

The SAE viscosity classes were defined by the Society of Automotive Engineers and are used for classifying oils according to their viscosity. The viscosity describes only one property of oil and says nothing about quality.

A	
Accessories	7
Air filter	
cleaning	48
installing	47
removing	47
Air filter housing	
cleaning	48
installing	47
removing	46
Antifreeze	
checking	82
Auxiliary substances	7
B	
Basic chassis setting	
checking with rider's weight	30
Battery	
installing	74
recharging	75
removing	74
Brake discs	
checking	61
Brake fluid	
front brake, adding	62
rear brake, adding	66
Brake fluid level	
front brake, checking	62
rear brake, checking	66
Brake linings	
front brake, changing	63
front brake, checking	63
rear brake, changing	67
rear brake, checking	67
Brake system	61-69
C	
Capacity	
coolant	84, 99
engine oil	89, 99
fuel	27, 99
Chain	
checking	55
cleaning	53
Chain guide	
checking	55
Chain tension	
adjusting	54
checking	53
Chassis number	10
Clutch	
fluid level, checking	58
fluid level, correcting	58
fluid, changing	59
Clutch lever	12
basic position, adjusting	58

Combination instrument	
overview	18
Compression damping	
fork, adjusting	35
Compression damping, high-speed	
shock absorber, adjusting	31
Compression damping, low-speed	
shock absorber, adjusting	30
Coolant	
draining	83
refilling	84
Coolant level	
checking	82-83
Cooling system	82
Customer service	7
E	
Electric starter button	13
Emergency OFF switch	13
Engine	
running in	23
Engine guard	
installing	60
removing	60
Engine number	10
Engine oil	
adding	90
changing	88
Engine oil level	
checking	87
Engine sprocket	
checking	55
Environment	6
F	
Figures	7
Filler cap	
closing	14
opening	14
Filling up	
fuel	27
Flash code	96
Foot brake lever	15
basic position, adjusting	65
free travel, checking	65
Fork legs	
basic setting, checking	34
bleeding	37
dust boots, cleaning	38
installing	39
removing	38
Fork protector	
installing	40
removing	39
Frame	
checking	56

Front fender	
installing	44
removing	44
Front wheel	
installing	70
removing	70
Fuel screen	
changing	87
Fuel tank	
installing	51
removing	50
Fuse	
individual power consumers, changing	77
main fuse, changing	76
H	
Hand brake lever	12
free travel, adjusting	61
free travel, checking	61
Handlebar position	35
adjusting	36
Headlight	
headlight range, adjusting	80
Headlight bulb	
changing	79
Headlight mask with headlight	
installing	78
removing	78
Headlight setting	
checking	80
Horn button	12
I	
Idle speed	
adjusting	86
Idle speed adjusting screw	15
Intended use	5
K	
Key number	10
Kill switch	12
L	
Light switch	13
Lower triple clamp	
installing	41
removing	40
M	
Main fuse	
changing	76
Main silencer	
glass fiber yarn filling, changing	50
installing	49
removing	48
Motorcycle	
cleaning	91
raising with lift stand	37
removing from the lift stand	37

O	
Oil filter	
changing	88
Oil screen	
cleaning	88
Operating substances	7
Overview of indicator lamps	14
Owner's Manual	6
P	
Play in the throttle cable	
adjusting	85
checking	85
Preparing for use	
advice on first use	22
after storage	93
checks and maintenance work when preparing for use	24
Protective clothing	6
R	
Rear sprocket	
checking	55
Rear wheel	
installing	71
removing	71
Rebound damping	
fork, adjusting	35
shock absorber, adjusting	31
Riding sag	
adjusting	34
Rubber grip	
checking	57
securing	58
S	
Safe operation	6
Seat	
folding up	45
locking	45
Service	7
Service schedule	28-29
Shift lever	15
basic position, adjusting	86
basic position, checking	86
Shock absorber	
installing	44
removing	44
riding sag, checking	33
spring preload, adjusting	33
static sag, checking	32
Side stand	16
Spare parts	7
Speedometer	
battery, changing	81
clock, setting	20
kilometers or miles, setting	19
message	18
service display, setting	20

setting	18
Spoiler	
mounting	46
removing	45
Spoke tension	
checking	73
Starting	24
Steering	
locking	16
unlocking	17
Steering head bearing	
greasing	43
Steering head bearing play	
adjusting	43
checking	42
Storage	93
Swingarm	
checking	57
T	
Technical data	
capacities	99
chassis	99
chassis tightening torques	101
electrical system	100
engine	97
engine tightening torques	97
fork	100
shock absorber	101
tires	100
Throttle cable routing	
checking	57
Throttle grip	12
Tire air pressure	
checking	73
Tire condition	
checking	72
Transport	26
Troubleshooting	94-95
Turn signal bulb	
changing	80
Turn signal switch	13
Type label	10
U	
Use definition	5
V	
View of vehicle	
left front	8
rear right	9
W	
Warranty	7
Winter operation	
checks and maintenance steps	92
Work rules	6



3213184en

09/2014



KTM Motorrad AG
5230 Mattighofen/Austria
<http://www.ktm.com>



KTM Group Partner



REG. NO. 12 100 6061

Photo: Mitterbauer/KTM