

450 EXC
450 EXC Six Days
450 XC-W
500 EXC
500 EXC Six Days
500 XC-W

Art. no. 3213434en



KTM

Perform the work described in these setup instructions before the vehicle is delivered to the customer.

Read the setup instructions in their entirety before beginning work.

These setup instructions were written to correspond to the latest state of this series. We reserve the right to make changes in the interest of technical advancement without at the same time updating this manual.

We shall not provide a description of general workshop methods. Likewise, safety rules that apply in a workshop are not specified here. It is assumed that the work will be performed by a fully trained mechanic.

All specifications are non-binding. KTM Sportmotorcycle GmbH specifically reserves the right to modify or delete technical specifications, prices, colors, forms, materials, services, designs, equipment, etc., without prior notice and without specifying reasons, to adapt these to local conditions, as well as to stop production of a particular model without prior notice. KTM accepts no liability for delivery options, deviations from illustrations and descriptions, misprints, and other errors. The models portrayed partly contain special equipment that does not belong to the regular scope of supply.

© 2015 KTM Sportmotorcycle GmbH, Mattighofen Austria

All rights reserved

Reproduction, even in part, as well as copying of all kinds, is permitted only with the express written permission of the copyright owner.



ISO 9001(12 100 6061)

According to the international quality management standard ISO 9001, KTM uses quality assurance processes that lead to the maximum possible quality of the products.

Issued by: TÜV Management Service

REG.NO. 12 100 6061

KTM Sportmotorcycle GmbH
5230 Mattighofen, Austria

This document is valid for the following models:

450 EXC EU (F8403P9)

450 EXC AU (F8460P9)

450 EXC Six Days EU (F8403P2)

450 XC-W US (F8475P3)

500 EXC EU (F8503P9)

500 EXC AU (F8560P9)

500 EXC US (F8575P9)

500 EXC Six Days EU (F8503P2)

500 XC-W US (F8575P3)



1.1 Symbols used

The meaning of specific symbols is described below.



Indicates an expected reaction (e.g. of a work step or a function).



Indicates an unexpected reaction (e.g. of a work step or a function).



Indicates a page reference (more information is provided on the specified page).



Indicates information with more details or tips.



Indicates the result of a testing step.



Denotes a voltage measurement.



Denotes a current measurement.



Denotes a resistance measurement.

1.2 Formats used

The typographical formats used in this document are explained below.

Proprietary name	Identifies a proprietary name.
Name[®]	Identifies a protected name.
Brand[™]	Identifies a trademark.
<u>Underlined terms</u>	Refer to technical details of the vehicle or indicate technical terms, which are explained in the glossary.

2.1 Unpacking and setting up the vehicle

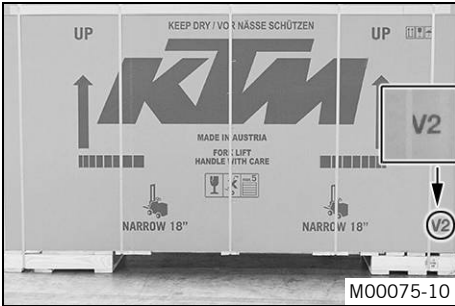

Package 2

- Remove the box and the plastic packaging.



Info

To avoid damaging the motorcycle during the setup, leave the protective film on the vehicle until you have finished.

- Remove the separate enclosure and unpack it. Check that the scope of supply is complete on the basis of the enclosed packing list.
- Have a lift stand available.

Lift stand (78129955100)

- Carefully loosen and remove the tension belt of the footrest mount.



Info

An assistant prevents the motorcycle from falling over.

- Together with an assistant, take the vehicle off the palette.
- Position the vehicle on a lift stand.
- Check the vehicle for transport damage.
- Remove the headlight mask with the headlight. (☛ p. 8)

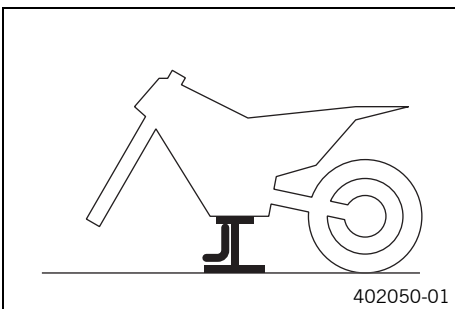

402050-01

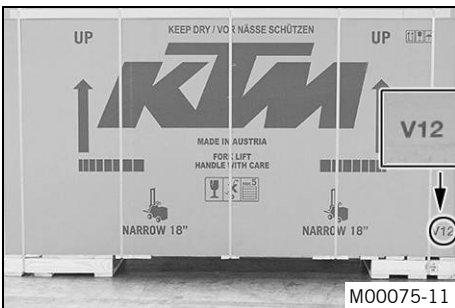

Package 12

- Remove the box and the plastic packaging.



Info

An assistant prevents the motorcycle from falling over.
To avoid damaging the motorcycle during the setup, leave the protective film on the vehicle until you have finished.

- Remove the separate enclosure and unpack it. Check that the scope of supply is complete on the basis of the enclosed packing list.

- Have a lift stand available.

Lift stand (78129955100)

- Together with an assistant, take the vehicle off the palette.
- Position the vehicle on a lift stand.
- Check the vehicle for transport damage.
- Install the shock absorber. (☛ p. 11)

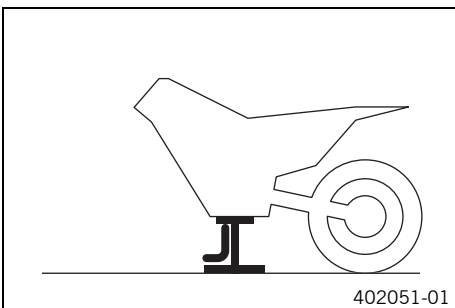

402051-01



600814-01

- Route the clutch line with the clutch master cylinder toward the front between the upper and lower triple clamps.

(XC-W, 500 EXC US)

- Position the fork legs and tighten the screws of the triple clamp.

Guideline

Screw, top triple clamp	M8	20 Nm (14.8 lbf ft)
Screw, bottom triple clamp	M8	15 Nm (11.1 lbf ft)



Info

Grooves are milled into the side of the upper end of the fork legs. The second milled groove (from the top) must be flush with the top edge of the upper triple clamp. Position the bleeder screws toward the front.

(EXC EU, EXC Six Days EU, EXC AU)

- Position the fork legs and tighten the screws of the triple clamp.

Guideline

Screw, top triple clamp	M8	17 Nm (12.5 lbf ft)
Screw, bottom triple clamp	M8	15 Nm (11.1 lbf ft)

i Info

The rebound damping is located in right fork leg **REB** (red adjusting screw). The compression damping is located in left fork leg **COMP** (white adjusting screw).

Grooves are milled into the side of the upper end of the fork legs. The topmost milled groove must be flush with the top edge of the upper triple clamp.

Position the bleeder screws toward the front.

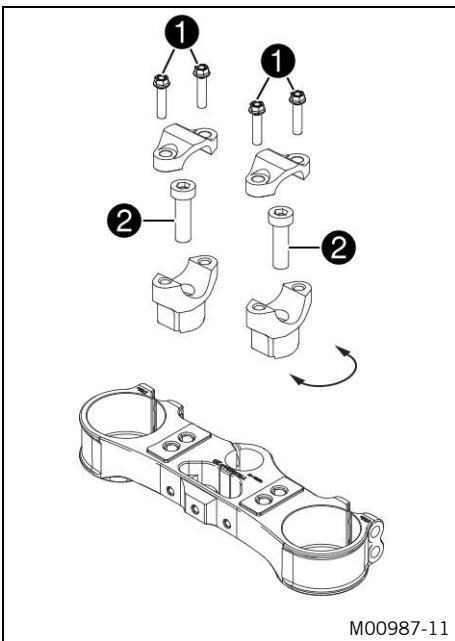

M00987-11

- Remove screws ①. Take off the handlebar clamps.
- Remove screws ②. Take off the handlebar supports.
- Place the handlebar supports in the required position. Mount and tighten screws ②.

Guideline

Screw, handlebar holder	M10	40 Nm (29.5 lbf ft)	Loctite® 243™
-------------------------	-----	------------------------	----------------------

i Info

Position the left and right handlebar supports evenly.

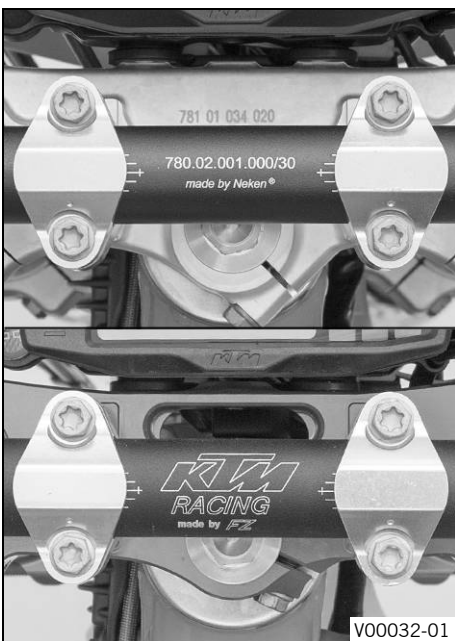

V00032-01

- Position the handlebar.

i Info

Make sure the cables and wiring are positioned correctly.

- Position the handlebar clamps. Mount and tighten the screws evenly.

Guideline

Screw, handlebar clamp	M8	20 Nm (14.8 lbf ft)
------------------------	----	------------------------

i Info

The markings on the handlebar should be at the center of the handlebar clamps.

Keep the gap widths equal when tightening.

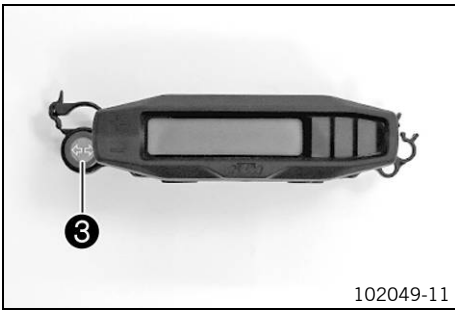

(EXC EU, EXC Six Days EU, EXC AU, 500 EXC US)

- Insert the indicator lamp with the black and violet cable colors into socket **3**.



(XC-W)

- Connect pull switch **3** with the yellow and white cables.
- Position the speedometer and connector board. Mount and tighten the screws.

Guideline

Remaining screws, chassis	M6	10 Nm (7.4 lbf ft)
---------------------------	----	-----------------------

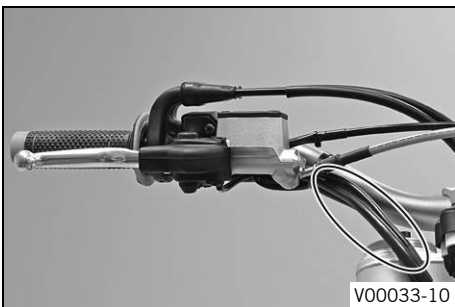

- Position the controls on the right half of the handlebar.

i Info
The routing of the throttle cables can be seen in the figure.



- Position the controls on the left half of the handlebar.

i Info
The figure shows how to route the clutch line and wiring harness.



(EXC EU, EXC Six Days EU, EXC AU, 500 EXC US)

- Remove the fuel tank. (☛ p. 17)
- Position the turn signal wiring harness against the main wiring harness and secure with cable ties.



- Disconnect the plug-in connection from the main wiring harness and connect the turn signal wiring harness.
- Install the fuel tank. (☛ p. 19)

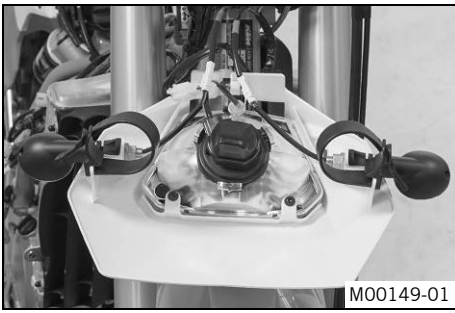

- Position the turn signal on each side and mount and tighten nuts.
- Connect the plug-in connection of the right turn signal using the black and brown cable colors.
- Connect the plug-in connection of the left turn signal using the violet and brown cable colors.

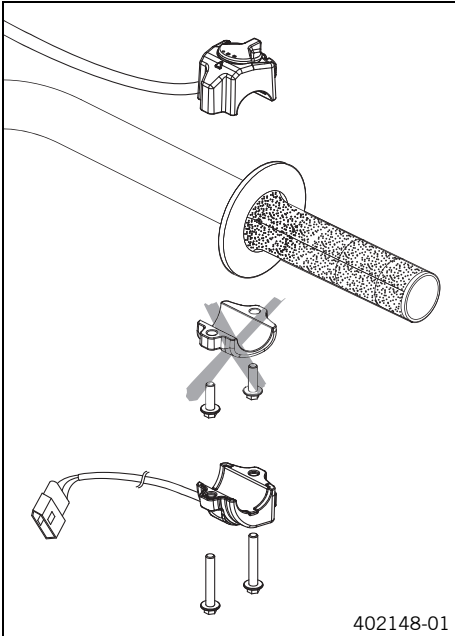

(EXC EU, EXC Six Days EU, EXC AU)

- Mount the turn signal switch.
- Install the front fender. (☛ p. 14)
- Refit the headlight mask with the headlight. (☛ p. 9)
- Install the front wheel. (☛ p. 13)
- Correctly mount the fuel tank breather.

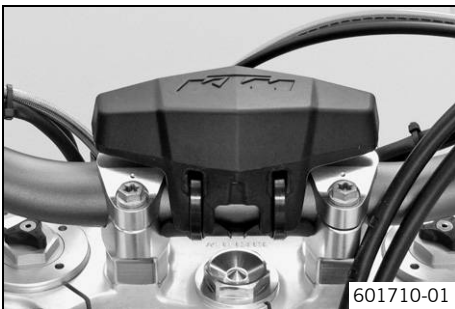

- Secure the handlebar cushion with two cable ties.

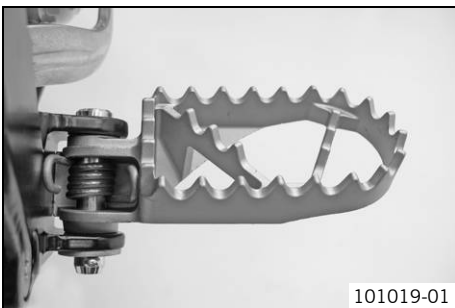

- Mount the footrests with the springs and pins. Secure the pins using the washers and cotter pins.

Pliers for footrest spring (58429083000)



(EXC EU, EXC Six Days EU, EXC AU)

- Mount the license plate holder with the license plate lamp, turn signals, and reflector.
- Connect the electrical components.
- Connect the connector of the left turn signal with the connector that is marked red.
- Connect the connector of the right turn signal with the connector that is marked green.



C00117-01

(500 EXC US)

- Mount the license plate holder with the license plate lamp, turn signals, and reflector.
- Connect the electrical components.
- Connect the connector of the left turn signal with the connector that is marked red.
- Connect the connector of the right turn signal with the connector that is marked green.

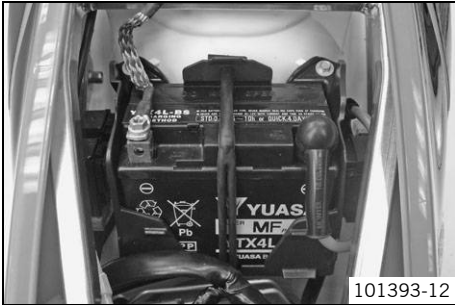

101393-12



Warning

Risk of injury Battery acid and battery gases cause serious chemical burns.

- Keep batteries out of the reach of children.
- Wear suitable protective clothing and goggles.
- Avoid contact with battery acid and battery gases.
- Keep sparks and open flames away from the battery. Only charge in well-ventilated rooms.
- In the event of skin contact, rinse with large amounts of water. If battery acid gets in the eyes, rinse with water for at least 15 minutes and contact a physician.

- Fill the battery.



Info

Read the notes in the battery package.

- Charge the battery. (☛ p. 16)
- Install the battery. (☛ p. 15)
- Unpack and mount the **KTM PowerParts** included in the delivery (optional).



Info

Read the accompanying **KTM PowerParts** fitting instructions.

- Apply the label included in the delivery (optional).
- Set kilometers or miles. (☛ p. 23)
- Set the speedometer functions. (☛ p. 24)
- Set the clock. (☛ p. 24)
- Refuel. (☛ p. 22)
- Position all controls in their exact positions on the handlebar. Tighten all screws.
- Prepare the vehicle according to the specifications in the **KTM Dealer.net** for hand-over to the customer.

3.1 Raising the motorcycle with the lift stand

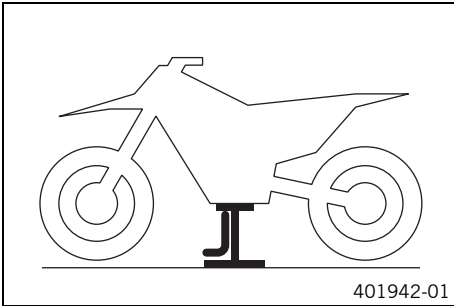

Note

Danger of damage The parked vehicle may roll away or fall over.

- Always place the vehicle on a firm and even surface.
- Raise the motorcycle at the frame underneath the engine.

Lift stand (78129955100)

- ✓ Neither wheel is in contact with the ground.
- Secure the motorcycle against falling over.

3.2 Removing the motorcycle from the lift stand

Note

Danger of damage The parked vehicle may roll away or fall over.

- Always place the vehicle on a firm and even surface.

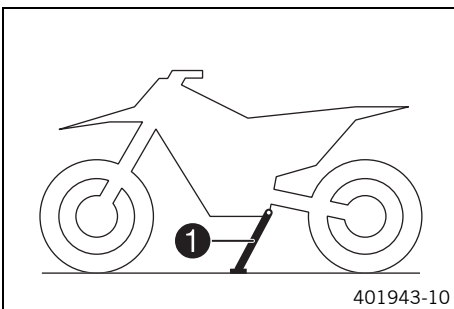

- Remove the motorcycle from the lift stand.
- Remove the lift stand.
- To park the motorcycle, press side stand 1 to the ground with your foot and lean the motorcycle on it.

i Info

While riding, the side stand must be folded up and secured with the rubber band.

3.3 Removing headlight mask with headlight

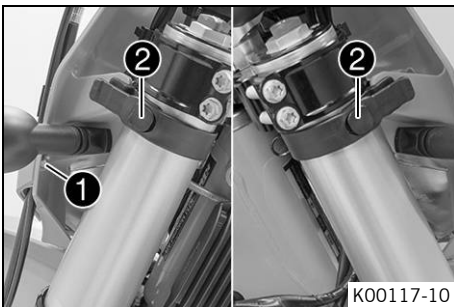

(EXC EU, EXC Six Days EU, EXC AU)

- Switch off all power consumers and switch off the engine.
- Remove screw 1 and take off the clamp.
- Release rubber straps 2. Slide the headlight mask up and swing it forward.

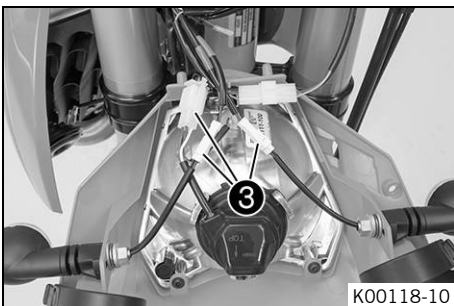

- Detach plug-in connectors 3 and take off the headlight mask with the headlight.

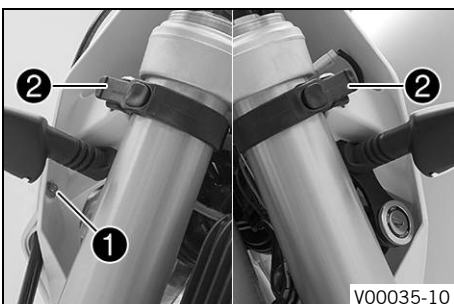

(500 EXC US)

- Switch off all power consumers and switch off the engine.
- Remove screw 1 and take off the clamp.
- Release rubber straps 2. Slide the headlight mask up and swing it forward.

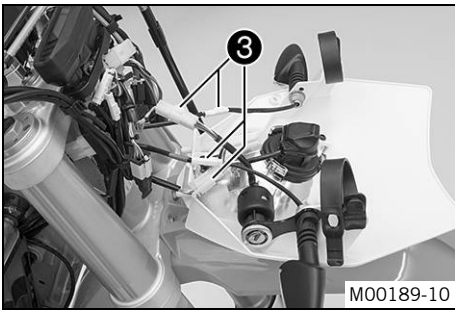

- Detach plug-in connectors **3** and take off the headlight mask with the headlight.

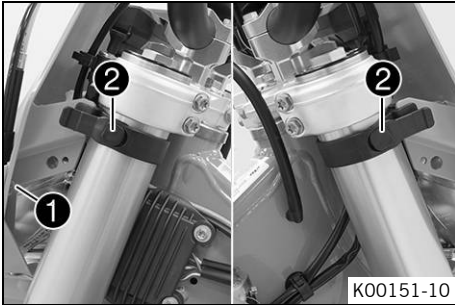

(XC-W)

- Switch off all power consumers and switch off the engine.
- Remove screw **1** and take off the clamp.
- Release rubber straps **2**. Slide the headlight mask up and swing it forward.

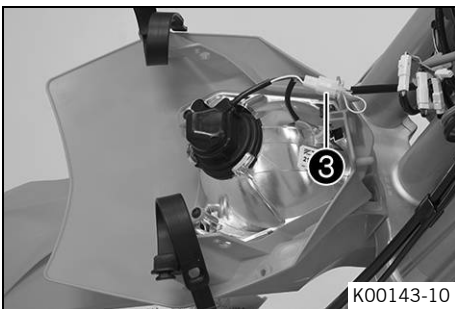

- Detach plug-in connector **3** and take off the headlight mask with the headlight.

3.4 Refitting the headlight mask with the headlight

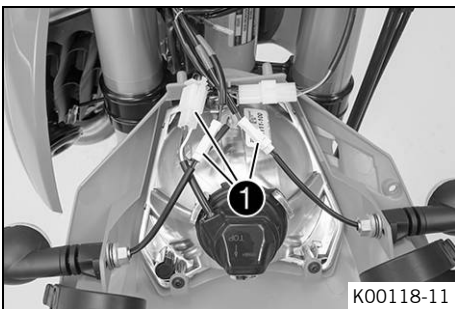

Main work

(EXC EU, EXC Six Days EU, EXC AU)

- Connect plug-in connectors **1**.

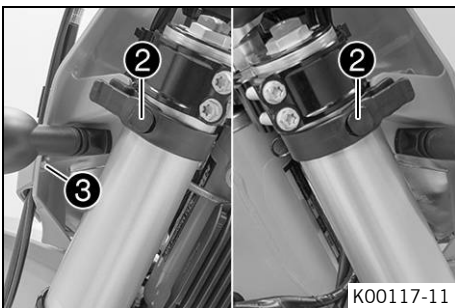

- Position the headlight mask and fix it with rubber straps **2**.



Info

Ensure the holding lugs engage in the fender.

- Position the brake line and wiring harness. Put the clamp on and mount and tighten screw **3**.

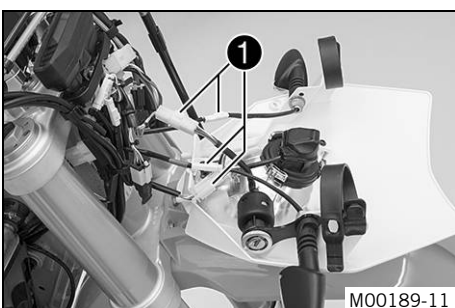

(500 EXC US)

- Connect plug-in connectors **1**.

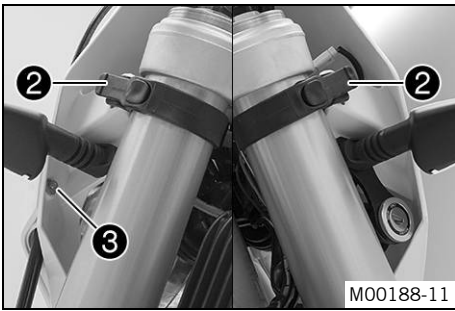

- Position the headlight mask and fix it with rubber straps ②.

i Info
Ensure the holding lugs engage in the fender.

- Position the brake line and wiring harness. Put the clamp on and mount and tighten screw ③.

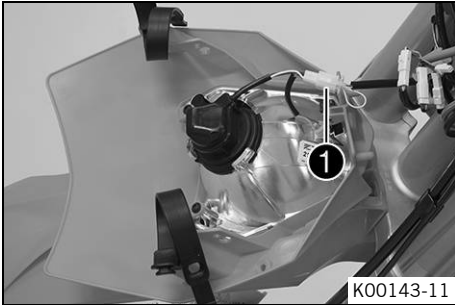

(XC-W)

- Connect plug-in connector ①.

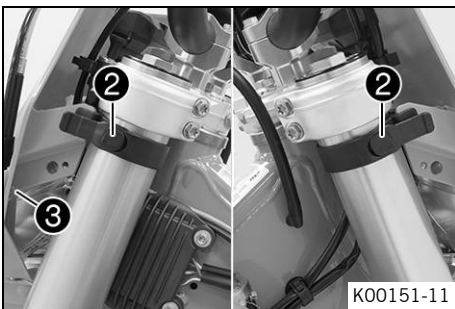

- Position the headlight mask and fix it with rubber straps ②.

i Info
Ensure the holding lugs engage in the fender.

- Position the brake line and wiring harness. Put the clamp on and mount and tighten screw ③.

Finishing work

- Check the headlight setting. (☛ p. 10)

3.5 Checking the headlight setting

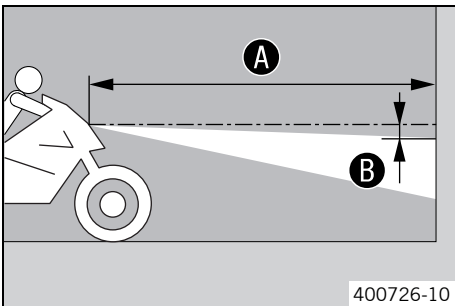

- Position the vehicle upright on a horizontal surface in front of a light wall and make a mark at the height of the center of the low beam headlight.
- Make another mark a distance ② under the first mark.

Guideline

Distance ②	5 cm (2 in)
------------	-------------

- Position the vehicle vertically at a distance ① away from the wall.

Guideline

Distance ①	5 m (16 ft)
------------	-------------

- The rider now sits down on the motorcycle.
- Switch on the low beam.
- Check the headlight setting.

The boundary between light and dark must be exactly on the lower mark for a motorcycle with driver.

- » If the light-dark border does not meet specifications:
 - Adjust the headlight range. (☛ p. 11)

3.6 Adjusting the headlight range

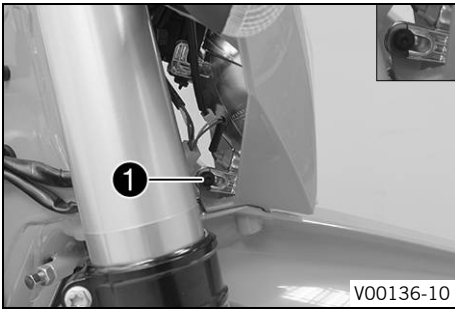

V00136-10

Preparatory work

- Check the headlight setting. (☛ p. 10)

Main work

(EXC EU, EXC Six Days EU, EXC AU)

- Loosen screw ①.
- Adjust the headlight range by pivoting the headlight.

Guideline

The boundary between light and dark must be exactly on the lower marking for a motorcycle with rider (instructions on how to apply the marking: Checking the headlight setting).



Info

A change in weight on the vehicle may require a correction of the headlight range.

- Tighten screw ①.

(500 EXC US)

- Loosen screw ①.
- Adjust the headlight range by pivoting the headlight.

Guideline

The boundary between light and dark must be exactly on the lower marking for a motorcycle with rider (instructions on how to apply the marking: Checking the headlight setting).



Info

A change in weight on the vehicle may require a correction of the headlight range.

- Tighten screw ①.

(XC-W)

- Loosen screw ①.
- Adjust the headlight range by pivoting the headlight.

Guideline

The boundary between light and dark must be exactly on the lower marking for a motorcycle with rider (instructions on how to apply the marking: Checking the headlight setting).



Info

A change in weight on the vehicle may require a correction of the headlight range.

- Tighten screw ①.

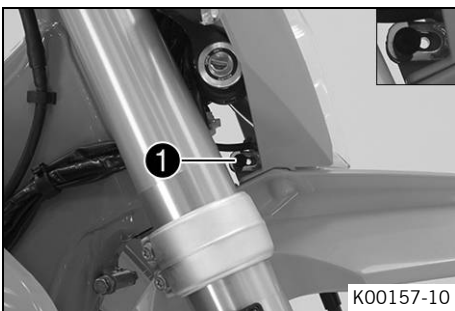

K00157-10

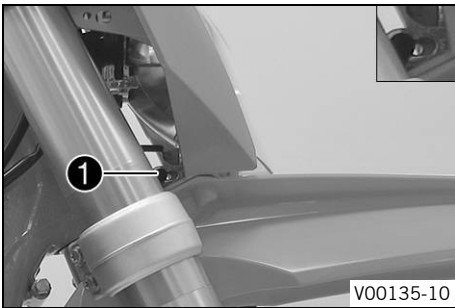

V00135-10

3.7 Installing the shock absorber

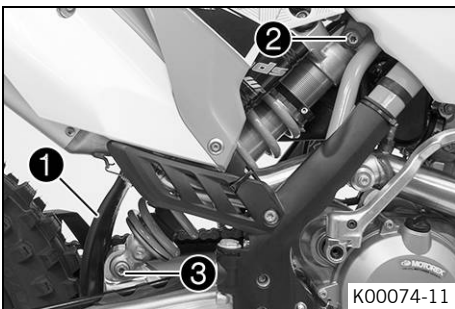

K00074-11

Main work

- Push splash protector ① to the side and position the shock absorber. Mount and tighten screw ②.

Guideline

Screw, top shock absorber	M12	80 Nm (59 lbf ft)	Loctite® 2701™
---------------------------	-----	----------------------	----------------

- Mount and tighten screw ③.

Guideline

Screw, bottom shock absorber	M12	80 Nm (59 lbf ft)	Loctite® 2701™
------------------------------	-----	----------------------	----------------



Info

The heim joint for the shock absorber at the swingarm is Teflon-coated. It must not be greased with grease or with other lubricants. Lubricants dissolve the Teflon coating, thereby drastically reducing the service life.

Finishing work

- Remove the motorcycle from the lift stand. (☛ p. 8)

3.8 Removing the front wheel

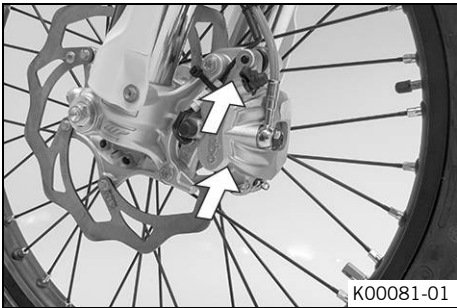

Preparatory work

- Raise the motorcycle with the lift stand. (☛ p. 8)

Main work

- Press the brake caliper onto the brake disc by hand in order to push back the brake pistons.



Info

Make sure when pushing back the brake pistons that you do not press the brake caliper against the spokes.

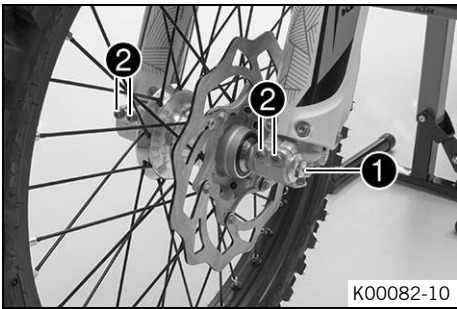

- Loosen screw ① by several turns.
- Release screws ②.
- Press on screw ① to push the wheel spindle out of the axle clamp.
- Remove screw ①.

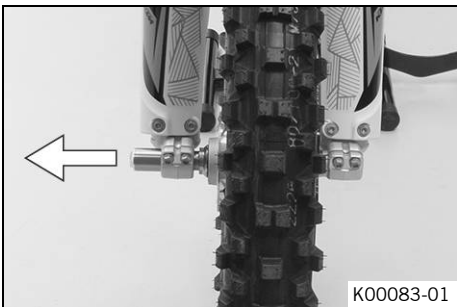

- Holding the front wheel, withdraw the wheel spindle. Take the front wheel out of the fork.



Info

Do not pull the hand brake lever when the front wheel is removed. Always lay the wheel down in such a way that the brake disc is not damaged.

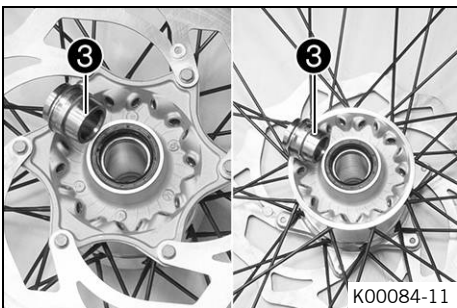

- Remove spacers ③.

3.9 Installing the front wheel



Warning

Danger of accidents Reduced braking efficiency due to oil or grease on the brake discs.

- Always keep the brake discs free of oil and grease, and clean them with brake cleaner when necessary.

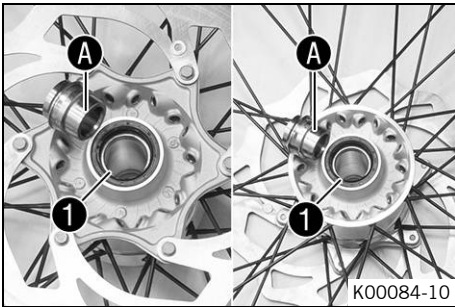

- Check the wheel bearing for damage and wear.
 - » If the wheel bearing is damaged or worn:
 - Change the front wheel bearing. (☛ p. 13)
- Clean and grease shaft seal rings **1** and bearing surface **A** of the spacers.

Long-life grease (☛ p. 28)

- Insert the spacers.
- Position the front wheel and insert the wheel spindle.
 - ✓ The brake linings are correctly positioned.

(EXC Six Days)

- Align the brake disc guard so that gaps **A** and **B** are the same size.

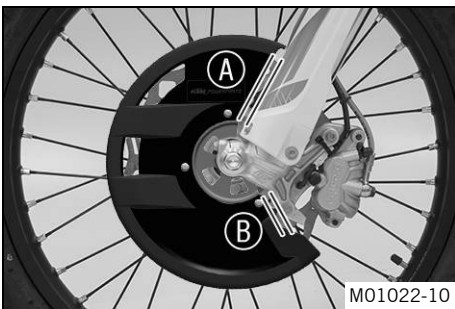

- Mount and tighten screw **2**.

Guideline

Screw, front wheel spindle	M20x1.5	35 Nm (25.8 lbf ft)
----------------------------	---------	------------------------

- Activate the hand brake lever multiple times until the brake linings are in contact with the brake disc.
- Remove the motorcycle from the lift stand. (☛ p. 8)
- Pull the front wheel brake and push down hard on the fork several times to align the fork legs.
- Fully tighten screw **3**.

Guideline

Screw, fork stub	M8	15 Nm (11.1 lbf ft)
------------------	----	------------------------

3.10 Changing the front wheel bearing

Preparatory work

- Raise the motorcycle with the lift stand. (☛ p. 8)
- Remove the front wheel. (☛ p. 12)

Main work

- Remove shaft seal rings **1** and **2**.

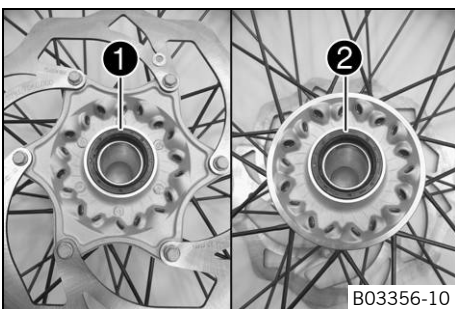

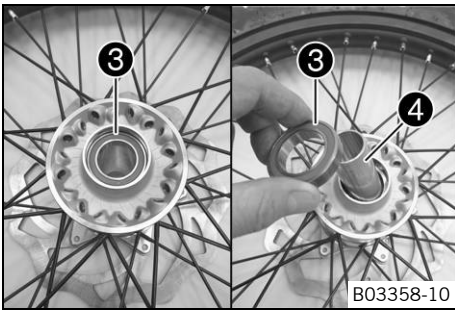

B03358-10

- Press out bearing 3 using a suitable tool.

i Info
Spacing tube 4 can be pushed aside.

- Remove spacing tube 4.

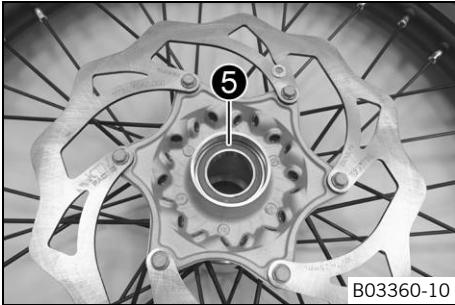

B03360-10

- Press out bearing 5 using a suitable tool.
- Press in the new bearing 5 all the way using a suitable tool.

i Info
Only press the bearing in via the outer ring; otherwise, the bearing will be damaged when it is pressed in.

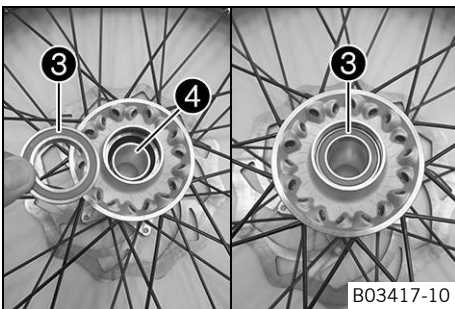

B03417-10

- Position spacing tube 4.
- Press in the new bearing 3 all the way using a suitable tool.

i Info
Only press the bearing in via the outer ring; otherwise, the bearing will be damaged when it is pressed in.

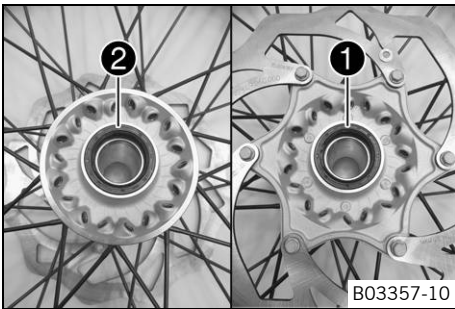

B03357-10

- Grease the new shaft seal rings 2 and 1 and press in until they are flush.

Finishing work

- Install the front wheel. (p. 13)

3.11 Installing the front fender

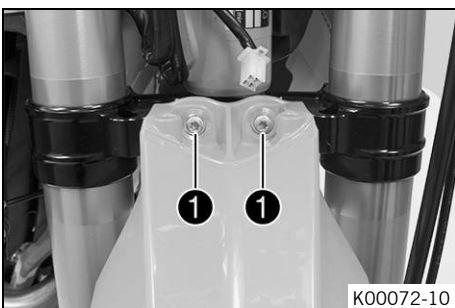

K00072-10

Main work

- Position the front fender. Mount and tighten screws 1.

Guideline

Remaining screws, chassis	M6	10 Nm (7.4 lbf ft)
---------------------------	----	--------------------

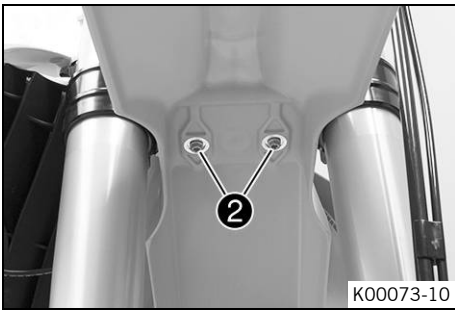

K00073-10

- Mount and tighten screws ②.

Guideline

Remaining screws, chassis	M6	10 Nm (7.4 lbf ft)
---------------------------	----	--------------------

Finishing work

- Refit the headlight mask with the headlight. (☛ p. 9)
- Check the headlight setting. (☛ p. 10)

3.12 Removing the seat

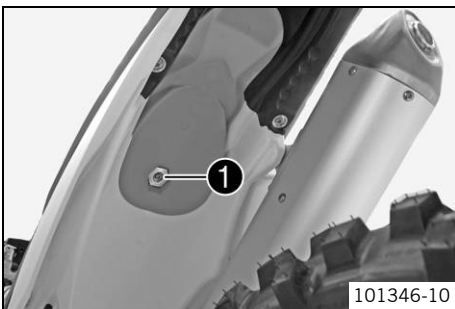

101346-10

- Remove screw ①.
- Lift up the seat at the rear, pull it back and then remove it from above.

3.13 Mounting the seat

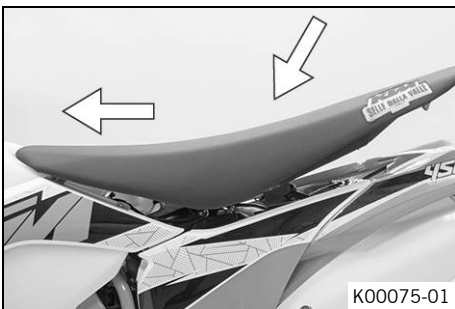

K00075-01

- Mount the front the seat on to the collar bushing of the fuel tank, lower it at the rear and simultaneously push it forward.
- Make sure that the seat is correctly locked in.
- Mount and tighten the screw of the seat fixing.

Guideline

Remaining screws, chassis	M6	10 Nm (7.4 lbf ft)
---------------------------	----	--------------------

3.14 Installing the battery

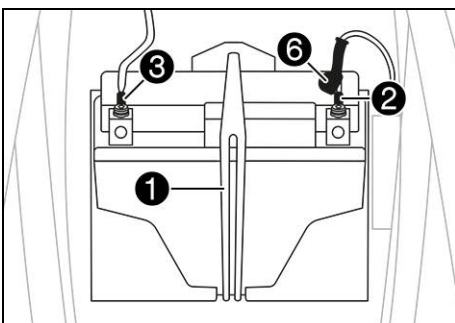

H00383-10

Main work

- Insert the battery into the battery compartment with the terminals facing forward.

Battery (YTX5L-BS)

- Reconnect rubber band ①.
- Position positive cable ② and mount and tighten the screw.

Guideline

Screw, battery terminal	M5	2.5 Nm (1.84 lbf ft)
-------------------------	----	-------------------------



Info

Contact disks **A** must be mounted under screws ④ and cable sockets ⑤ with the claws toward the battery terminal.

- Slide positive terminal cover ⑥ over the positive terminal.
- Position negative cable ③ and mount and tighten the screw.

Guideline

Screw, battery terminal	M5	2.5 Nm (1.84 lbf ft)
-------------------------	----	-------------------------

Finishing work

- Install the air filter box cover. (☛ p. 17)

- Mount the seat. (🔗 p. 15)

3.15 Charging the battery



Warning

Risk of injury Battery acid and battery gases cause serious chemical burns.

- Keep batteries out of the reach of children.
- Wear suitable protective clothing and goggles.
- Avoid contact with battery acid and battery gases.
- Keep sparks and open flames away from the battery. Only charge in well-ventilated rooms.
- In the event of skin contact, rinse with large amounts of water. If battery acid gets in the eyes, rinse with water for at least 15 minutes and contact a physician.



Warning

Environmental hazard The battery contains elements that are harmful to the environment.

- Do not dispose of batteries with the household waste. Dispose of a defective battery in an environmentally friendly manner. Give the battery to your authorized KTM dealer or dispose of it at a collection point for used batteries.



Warning

Environmental hazard Hazardous substances cause environmental damage.

- Oil, grease, filters, fuel, cleaners, brake fluid, etc., should be disposed of as stipulated in applicable regulations.



Info

Even when there is no load on the battery, it still loses power steadily.

The charge state and the type of charge are very important for the service life of the battery.

Rapid recharging with a high charging current shortens the battery's service life.

If the charging current, charging voltage and charging time are exceeded, electrolyte escapes through the safety valves. This reduces the battery capacity.

If the battery is depleted by repeated starting, the battery must be charged immediately.

If the battery is left in a discharged state for an extended period, it will become over-discharged and sulfate, destroying the battery.

The battery is maintenance-free. The acid level does not have to be checked.



Preparatory work

- Switch off all power consumers and switch off the engine.
- Remove the seat. (🔗 p. 15)
- To prevent damage to the onboard electronics, disconnect the negative cable from the battery.

Main work

- Connect the battery charger with the battery. Switch on the battery charger.

Battery charger (58429074000)

You can also use the battery charger to test the open-circuit voltage and starting voltage of the battery, and to test the alternator. With this device, you cannot over-charge the battery.



Info

Never remove lid ①.

Charge the battery with a maximum of 10% of the capacity specified on battery housing ②.

- Switch off the battery charger after charging and disconnect from the battery.

Guideline

The charge current, charge voltage, and charge time must not be exceeded.	
---	--

Charge the battery regularly when the motorcycle is not in use	3 months
--	----------

- Connect the negative cable with the battery.

Guideline

Screw, battery terminal	M5	2.5 Nm (1.84 lbf ft)
-------------------------	----	-------------------------

Finishing work

- Mount the seat. (☛ p. 15)

3.16 Installing the air filter box cover

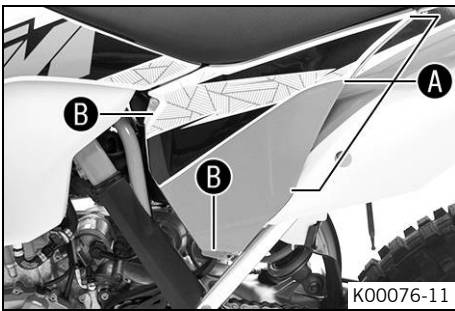

(EXC AU, EXC EU, EXC SIX DAYS, XC-W)

- Insert the air filter box cover into rear area **A** and clip it into front area **B**.

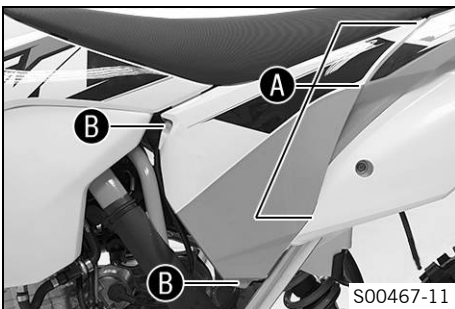

(500 EXC US)

- Insert the air filter box cover into rear area **A** and clip it into front area **B**.

3.17 Removing the fuel tank



Danger

Fire hazard Fuel is highly flammable.

- Never refuel the vehicle near open flames or burning cigarettes, and always switch off the engine first. Be careful that no fuel is spilt, especially on hot vehicle components. Clean up spilt fuel immediately.
- The fuel in the fuel tank expands when warm and may emerge if overfilled. Follow the instructions on refueling.



Warning

Danger of poisoning Fuel is poisonous and a health hazard.

- Fuel must not come into contact with the skin, eyes, or clothing. Do not breathe in the fuel vapors. If contact occurs with the eyes, rinse with water immediately and contact a physician. Immediately clean contaminated areas on the skin with soap and water. If fuel is swallowed, contact a physician immediately. Change clothing that has been contaminated with fuel. Store fuel properly in a suitable canister and keep away from children.

Preparatory work

- Remove the seat. (☛ p. 15)

Main work

- Detach connector **1** of the fuel pump.
- Remove the tube from the fuel tank breather.

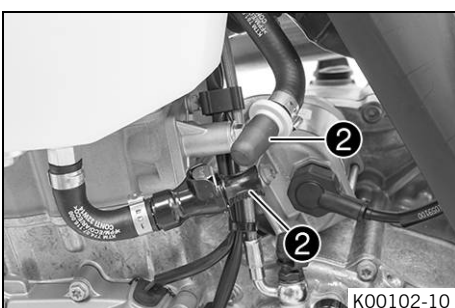
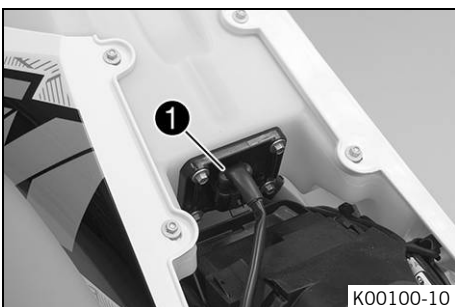

(EXC AU, EXC EU, EXC SIX DAYS, XC-W)

- Thoroughly clean the plug-in connection of the fuel line using compressed air.



Info

Under no circumstances should dirt enter into the fuel line. Dirt in the fuel line clogs the injection valve.

- Disconnect the plug-in connection of the fuel line.

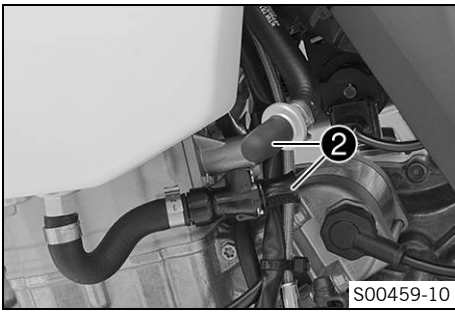

- Mount the wash cap set ②.

Wash cap set (81212016100)

(500 EXC US)

- Thoroughly clean the plug-in connection of the fuel line using compressed air.



Info

Under no circumstances should dirt enter into the fuel line. Dirt in the fuel line clogs the injection valve.

- Disconnect the plug-in connection of the fuel line.
- Mount the wash cap set ②.

Wash cap set (81212016100)

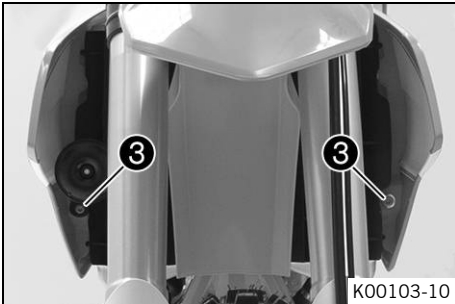

(EXC EU, EXC AU)

- Disconnect the connector of the horn.
- Remove screws ③ with the collar bushings and horn.

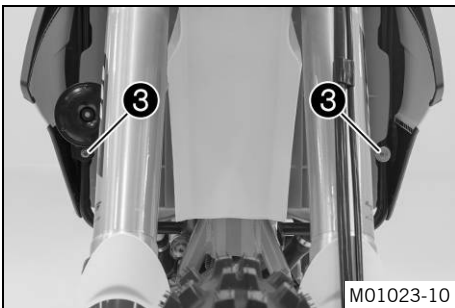

(EXC Six Days)

- Disconnect the connector of the horn.
- Remove screws ③ with the collar bushings and horn.

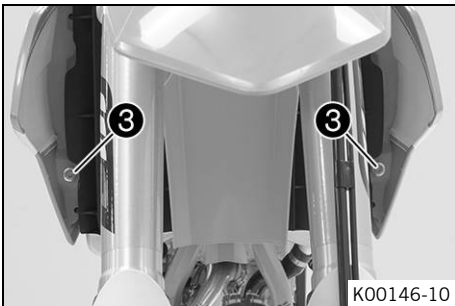

(XC-W, 500 EXC US)

- Remove screws ③ with the collar bushings.



- Remove screw ④ with the rubber bushing.

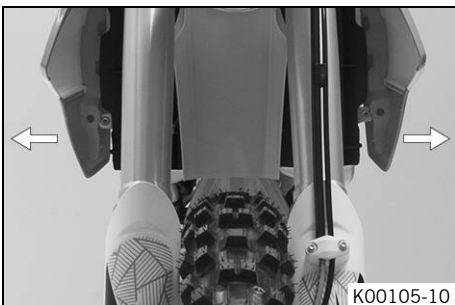

(EXC EU, EXC AU, XC-W, 500 EXC US)

- Pull both spoilers off of the sides of the radiator bracket and lift off the fuel tank.

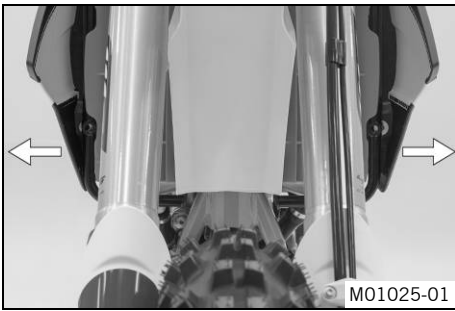

(EXC Six Days)

- Pull both spoilers off of the sides of the radiator bracket and lift off the fuel tank.

3.18 Installing the fuel tank



Danger

Fire hazard Fuel is highly flammable.

- Never refuel the vehicle near open flames or burning cigarettes, and always switch off the engine first. Be careful that no fuel is spilt, especially on hot vehicle components. Clean up spilt fuel immediately.
- The fuel in the fuel tank expands when warm and may emerge if overfilled. Follow the instructions on refueling.



Warning

Danger of poisoning Fuel is poisonous and a health hazard.

- Fuel must not come into contact with the skin, eyes, or clothing. Do not breathe in the fuel vapors. If contact occurs with the eyes, rinse with water immediately and contact a physician. Immediately clean contaminated areas on the skin with soap and water. If fuel is swallowed, contact a physician immediately. Change clothing that is contaminated with fuel.

Main work

- Check throttle cable routing. (☛ p. 20)

(EXC EU, EXC AU, XC-W, 500 EXC US)

- Position the fuel tank and fit the two spoilers to the sides in front of the radiator bracket.
- Make sure that the throttle cable or other cables are not trapped or damaged.

(EXC Six Days)

- Position the fuel tank and fit the two spoilers to the sides between the radiator and radiator shield.
- Make sure that no cables are trapped or damaged.
- Mount the fuel tank breather.
- Mount and tighten screw ❶ with the rubber bushing.

Guideline

Remaining screws, chassis	M6	10 Nm (7.4 lbf ft)
---------------------------	----	--------------------

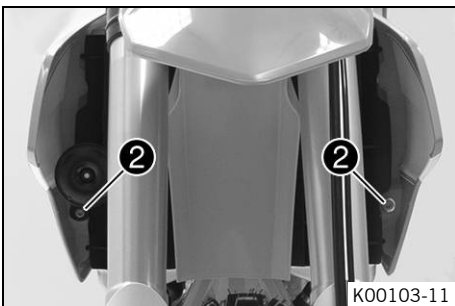

(EXC EU, EXC AU)

- Position the collar bushings and horn, and mount and tighten screws ❷.

Guideline

Remaining screws, chassis	M6	10 Nm (7.4 lbf ft)
---------------------------	----	--------------------

- Connect the connector of the horn.

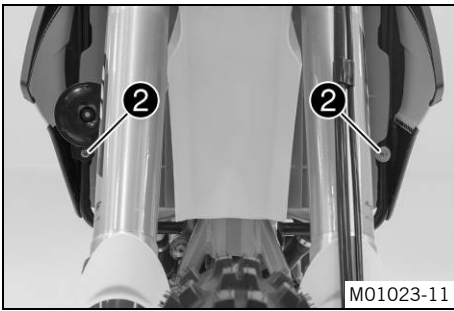

(EXC Six Days)

- Position collar bushings between the spoiler and radiator shield.
- Position the horn, and fit and tighten screws ② with washers.

Guideline

Remaining screws, chassis	M6	10 Nm (7.4 lbf ft)
---------------------------	----	-----------------------

- Connect the connector of the horn.

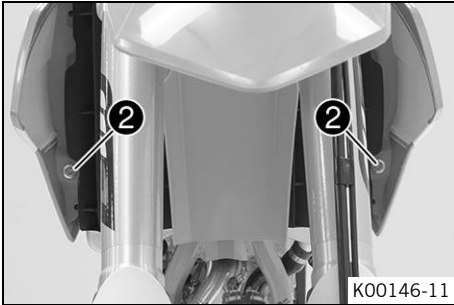

(XC-W, 500 EXC US)

- Position the collar bushings, and mount and tighten screws ②.

Guideline

Remaining screws, chassis	M6	10 Nm (7.4 lbf ft)
---------------------------	----	-----------------------

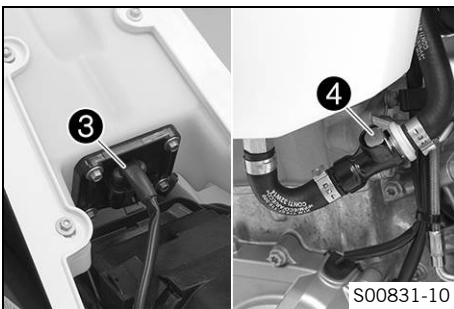

(EXC AU, EXC EU, EXC SIX DAYS, XC-W)

- Plug in connector ③ of the fuel pump.
- Remove the wash cap set.
- Thoroughly clean the plug-in connection of the fuel line using compressed air.

i Info
Under no circumstances should dirt enter into the fuel line. Dirt in the fuel line clogs the injection valve.

- Lubricate the O-ring and connect plug-in connection ④ of the fuel line.

i Info
Route the cable and fuel line at a safe distance from the exhaust system.

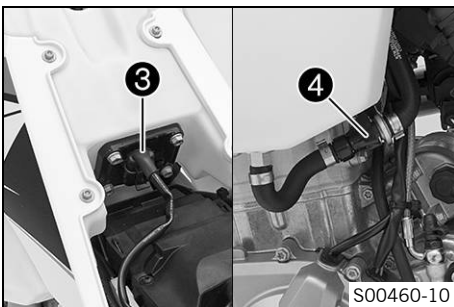

(500 EXC US)

- Plug in connector ③ of the fuel pump.
- Remove the wash cap set.
- Thoroughly clean the plug-in connection of the fuel line using compressed air.

i Info
Under no circumstances should dirt enter into the fuel line. Dirt in the fuel line clogs the injection valve.

- Lubricate the O-ring and connect plug-in connection ④ of the fuel line.

i Info
Route the cable and fuel line at a safe distance from the exhaust system.

Finishing work

- Mount the seat. (☛ p. 15)

3.19 Checking throttle cable routing

Preparatory work

- Remove the seat. (☛ p. 15)
- Remove the fuel tank. (☛ p. 17)



K00110-01

Main work
(EXC EU, EXC Six Days EU, EXC AU)

- Check throttle cable routing.

Both throttle cables must be routed, side by side, on the back of the handlebars and above the fuel tank bracket, to the throttle valve body.

- » If the throttle cable routing is not as specified:
 - Correct throttle cable routing.



K00158-01

(XC-W, 500 EXC US)

- Check throttle cable routing.

Both throttle cables must be routed, side by side, on the back of the handlebars and above the fuel tank bracket, to the throttle valve body.

- » If the throttle cable routing is not as specified:
 - Correct throttle cable routing.

Finishing work

- Install the fuel tank. (☛ p. 19)
- Mount the seat. (☛ p. 15)

3.20 Opening the filler cap



Danger

Fire hazard Fuel is highly flammable.

- Never refuel the vehicle near open flames or burning cigarettes, and always switch off the engine first. Be careful that no fuel is spilt, especially on hot vehicle components. Clean up spilt fuel immediately.
- The fuel in the fuel tank expands when warm and may emerge if overfilled. Follow the instructions on refueling.



Warning

Danger of poisoning Fuel is poisonous and a health hazard.

- Fuel must not come into contact with the skin, eyes, or clothing. Do not breathe in the fuel vapors. If contact occurs with the eyes, rinse with water immediately and contact a physician. Immediately clean contaminated areas on the skin with soap and water. If fuel is swallowed, contact a physician immediately. Change clothing that has been contaminated with fuel. Store fuel properly in a suitable canister and keep away from children.



Warning

Environmental hazard Improper handling of fuel is a danger to the environment.

- Do not allow fuel to get into the ground water, the ground, or the sewage system.

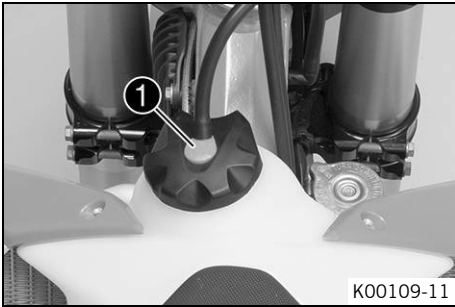

(EXC EU, EXC Six Days EU, EXC AU)

- Press release button **1**, turn the filler cap counterclockwise, and lift it off.



(XC-W, 500 EXC US)

- Press release button **1**, turn the filler cap counterclockwise, and lift it off.

3.21 Closing the filler cap

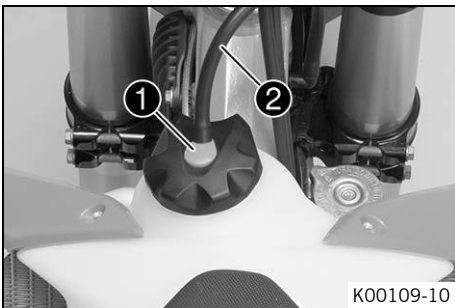

(EXC EU, EXC Six Days EU, EXC AU)

- Replace the filler cap and turn clockwise until release button **1** locks in place.



Info

Run the fuel tank breather hose **2** without kinks.

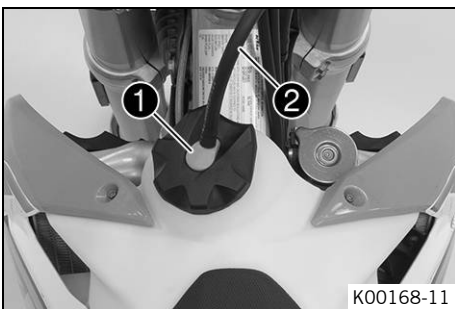

(XC-W, 500 EXC US)

- Replace the filler cap and turn clockwise until release button **1** locks in place.



Info

Run the fuel tank breather hose **2** without kinks.

3.22 Refueling



Danger

Fire hazard Fuel is highly flammable.

- Never refuel the vehicle near open flames or burning cigarettes, and always switch off the engine first. Be careful that no fuel is spilt, especially on hot vehicle components. Clean up spilt fuel immediately.
- The fuel in the fuel tank expands when warm and may emerge if overfilled. Follow the instructions on refueling.



Warning

Danger of poisoning Fuel is poisonous and a health hazard.

- Fuel must not come into contact with the skin, eyes, or clothing. Do not breathe in the fuel vapors. If contact occurs with the eyes, rinse with water immediately and contact a physician. Immediately clean contaminated areas on the skin with soap and water. If fuel is swallowed, contact a physician immediately. Change clothing that is contaminated with fuel.

Note

Material damage Premature clogging of the fuel filter.

- In some countries and regions, the available fuel quality and cleanliness may not be sufficient. This will result in problems with the fuel system.
- Only refuel with clean fuel that meets the specified standards.



Warning

Environmental hazard Improper handling of fuel is a danger to the environment.

- Do not allow fuel to get into the ground water, the ground, or the sewage system.

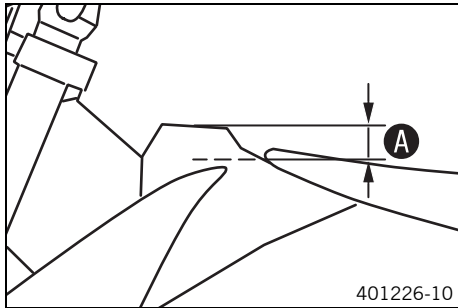

- Switch off engine.
- Open the filler cap. (☛ p. 21)
- Fill the fuel tank with fuel up to measurement **A**.

Guideline

Measurement of A	35 mm (1.38 in)	
Total fuel tank capacity, approx. (EXC EU, EXC Six Days EU, EXC AU)	9 l (2.4 US gal)	Super unleaded (ROZ 95/RON 95/PON 91) (☛ p. 27)
Total fuel tank capacity, approx. (XC-W, 500 EXC US)	8.5 l (2.25 US gal)	Super unleaded (ROZ 95/RON 95/PON 91) (☛ p. 27)

- Close the filler cap. (☛ p. 22)

3.23 Setting kilometers or miles



Info

If you change the unit, the value **ODO** is retained and converted accordingly. The values **TR1**, **TR2**, **A1**, **A2** and **S1** are cleared when the unit of measure is changed.

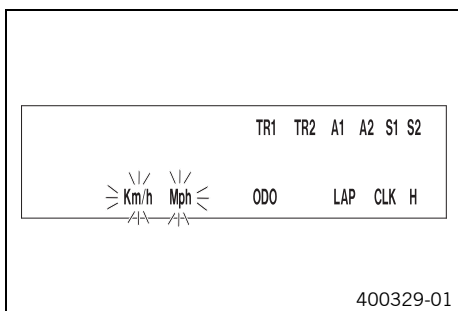

Condition

The motorcycle is stationary.

- Repeatedly press the button **+** briefly until **H** appears at the bottom right of the display.
- Press the button **+** for 2–3 seconds.
 - ✓ The Setup menu is displayed and the active functions are shown.
- Repeatedly press the button **+** briefly until **Km/h/Mph** flashes.

Setting the Km/h

- Press the button **+**.

Setting the Mph

- Press the button **-**.
- Wait 3–5 seconds
 - ✓ The settings are stored.



Info

If no button is pressed for 10 -12 seconds, or if an impulse comes from the wheel speed sensor, the settings are automatically saved and the setup menu is closed.

3.24 Setting the speedometer functions

**Info**

When the vehicle is delivered, only the **SPEED/H** and **SPEED/ODO** display modes are activated.

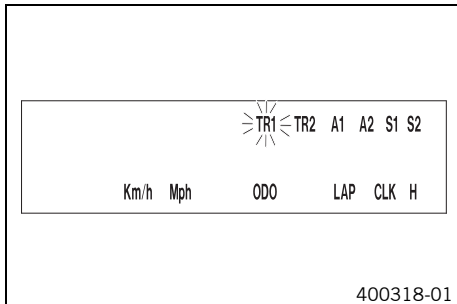
**Condition**

The motorcycle is stationary.

- Repeatedly press the button briefly until **H** appears at the bottom right of the display.
- Press the button for 2–3 seconds.
- ✓ The Setup menu is displayed and the active functions are shown.

**Info**

If no button is pressed for 10–12 seconds, the settings are automatically saved.

If no button is pressed for 20 seconds, or if an impulse comes from the wheel speed sensor, the settings are automatically saved and the setup menu is closed.

- Repeatedly press the button briefly until the desired function flashes.
- ✓ The selected function flashes.

Activating the function

- Press the button .
- ✓ The symbol continues to appear in the display and the next function appears.

Deactivating a function

- Press the button .
- ✓ The symbol disappears in the display and the next function appears.

3.25 Setting the clock

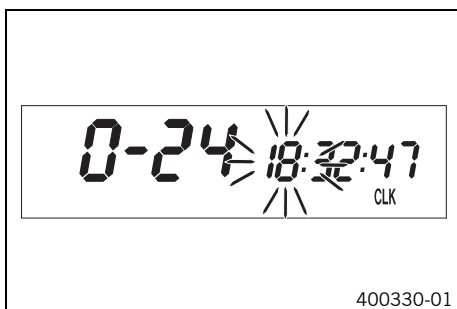
**Condition**

The motorcycle is stationary.

- Repeatedly press the button briefly until **CLK** appears at the bottom right of the display.
- Press the button for 2–3 seconds.
- ✓ The hour display flashes.
- Set the hour display with the button and/or button .
- Wait 3–5 seconds
- ✓ The next segment of the display flashes and can be set.
- You can set the following segments in the same way as the hours by pressing the button and the button .

**Info**

The seconds can only be set to zero.

If no button is pressed for 15–20 seconds, or if an impulse comes from the wheel speed sensor, the settings are automatically saved and the setup menu is closed.

4.1 Chassis tightening torques

Screw, pressure regulator	EJOT PT® K60x25-Z	3 Nm (2.2 lbf ft)	–
Spoke nipple, front wheel	M4.5	6 Nm (4.4 lbf ft)	–
Spoke nipple, rear wheel	M4.5	6 Nm (4.4 lbf ft)	–
Remaining nuts, chassis	M5	5 Nm (3.7 lbf ft)	–
Remaining screws, chassis	M5	5 Nm (3.7 lbf ft)	–
Screw, battery terminal	M5	2.5 Nm (1.84 lbf ft)	–
Screw, intake air temperature sensor	M5	2 Nm (1.5 lbf ft)	–
Screw, shock absorber adjusting ring	M5	5 Nm (3.7 lbf ft)	–
Screw, spoiler on fuel tank (XC-W, 500 EXC US)	M5x12	1.5 Nm (1.11 lbf ft)	–
Nut, cable on starter motor	M6	4 Nm (3 lbf ft)	–
Remaining nuts, chassis	M6	10 Nm (7.4 lbf ft)	–
Remaining screws, chassis	M6	10 Nm (7.4 lbf ft)	–
Screw, ball joint of push rod on foot brake cylinder	M6	10 Nm (7.4 lbf ft)	Loctite® 243™
Screw, chain sliding guard	M6	6 Nm (4.4 lbf ft)	Loctite® 243™
Screw, front brake disc	M6	14 Nm (10.3 lbf ft)	Loctite® 243™
Screw, rear brake disc	M6	14 Nm (10.3 lbf ft)	Loctite® 243™
Screw, throttle grip	M6	5 Nm (3.7 lbf ft)	–
Fuel connection on fuel pump	M8	10 Nm (7.4 lbf ft)	–
Nut, foot brake lever stop	M8	20 Nm (14.8 lbf ft)	–
Nut, rear sprocket screw	M8	35 Nm (25.8 lbf ft)	Loctite® 2701™
Nut, rim lock	M8	12 Nm (8.9 lbf ft)	–
Remaining nuts, chassis	M8	25 Nm (18.4 lbf ft)	–
Remaining screws, chassis	M8	25 Nm (18.4 lbf ft)	–
Screw, bottom triple clamp (EXC EU, EXC Six Days EU, EXC AU)	M8	15 Nm (11.1 lbf ft)	–
Screw, bottom triple clamp (XC-W, 500 EXC US)	M8	15 Nm (11.1 lbf ft)	–
Screw, chain sliding piece	M8	15 Nm (11.1 lbf ft)	–
Screw, engine brace	M8	33 Nm (24.3 lbf ft)	Loctite® 2701™
Screw, fork stub	M8	15 Nm (11.1 lbf ft)	–
Screw, front brake caliper	M8	25 Nm (18.4 lbf ft)	Loctite® 243™
Screw, handlebar clamp	M8	20 Nm (14.8 lbf ft)	–
Screw, side stand attachment	M8	35 Nm (25.8 lbf ft)	Loctite® 2701™
Screw, subframe	M8	35 Nm (25.8 lbf ft)	Loctite® 2701™
Screw, top steering stem (EXC EU, EXC Six Days EU, EXC AU)	M8	17 Nm (12.5 lbf ft)	Loctite® 243™
Screw, top steering stem (XC-W, 500 EXC US)	M8	20 Nm (14.8 lbf ft)	–
Screw, top triple clamp (EXC EU, EXC Six Days EU, EXC AU)	M8	17 Nm (12.5 lbf ft)	–
Screw, top triple clamp (XC-W, 500 EXC US)	M8	20 Nm (14.8 lbf ft)	–
Engine attachment bolt	M10	60 Nm (44.3 lbf ft)	–
Remaining nuts, chassis	M10	45 Nm (33.2 lbf ft)	–
Remaining screws, chassis	M10	45 Nm (33.2 lbf ft)	–
Screw, handlebar holder	M10	40 Nm (29.5 lbf ft)	Loctite® 243™
Nut, fuel pump fixation	M12	15 Nm (11.1 lbf ft)	–
Screw, bottom shock absorber	M12	80 Nm (59 lbf ft)	Loctite® 2701™
Screw, top shock absorber	M12	80 Nm (59 lbf ft)	Loctite® 2701™
Nut, seat fixing	M12x1	20 Nm (14.8 lbf ft)	–
Nut, swingarm pivot	M16x1.5	100 Nm (73.8 lbf ft)	–

4 TECHNICAL DATA

Nut, rear wheel spindle	M20x1.5	80 Nm (59 lbf ft)	–
Screw, front wheel spindle	M20x1.5	35 Nm (25.8 lbf ft)	–
Screw, top steering head	M20x1.5	12 Nm (8.9 lbf ft)	–
Screw-in nozzles, cooling system	M20x1.5	12 Nm (8.9 lbf ft)	Loctite® 243™

Super unleaded (ROZ 95/RON 95/PON 91)

Standard/classification

- DIN EN 228 (ROZ 95/RON 95/PON 91)

Guideline

- Only use unleaded super fuel that matches or is equivalent to the specified fuel grade.
- Fuel with an ethanol content of up to 10 % (E10 fuel) is safe to use.



Info

Do **not** use fuel containing methanol (e. g. M15, M85, M100) or more than 10 % ethanol (e. g. E15, E25, E85, E100).

Long-life grease

Recommended supplier

Motorex®

– Bike Grease 2000



3213434en

11/2015

