

Freeride 250 R

Art. no. 3213438en



KTM

The work described in these setup instructions must be performed before the vehicle is delivered to the customer.

Read the setup instructions in their entirety before beginning work.

These setup instructions were written to correspond to the latest state of this series. We reserve the right to make changes in the interest of technical advancement without at the same time updating this manual.

We shall not provide a description of general workshop methods. Likewise, safety rules that apply in a workshop are not specified here. It is assumed that the work will be performed by a fully trained mechanic.

All specifications are non-binding. KTM Sportmotorcycle GmbH specifically reserves the right to modify or delete technical specifications, prices, colors, forms, materials, services, designs, equipment, etc., without prior notice and without specifying reasons, to adapt these to local conditions, as well as to stop production of a particular model without prior notice. KTM accepts no liability for delivery options, deviations from illustrations and descriptions, misprints, and other errors. The models portrayed partly contain special equipment that does not belong to the regular scope of supply.

© 2015 KTM Sportmotorcycle GmbH, Mattighofen Austria

All rights reserved

Reproduction, even in part, as well as copying of all kinds, is permitted only with the express written permission of the copyright owner.



ISO 9001(12 100 6061)

According to the international quality management standard ISO 9001, KTM uses quality assurance processes that lead to the maximum possible quality of the products.

Issued by: TÜV Management Service

REG.NO. 12 100 6061

KTM Sportmotorcycle GmbH
5230 Mattighofen, Austria

This document is valid for the following models:

Freeride 250 R EU (F7303P4)

Freeride 250 R AU (F7360P4)

Freeride 250 R US (F7375P4)



1.1 Symbols used

The meaning of specific symbols is described below.



Indicates an expected reaction (e.g. of a work step or a function).



Indicates an unexpected reaction (e.g. of a work step or a function).



Indicates a page reference (more information is provided on the specified page).



Indicates information with more details or tips.



Indicates the result of a testing step.



Denotes a voltage measurement.



Denotes a current measurement.



Denotes a resistance measurement.

1.2 Formats used

The typographical formats used in this document are explained below.

Proprietary name	Identifies a proprietary name.
Name[®]	Identifies a protected name.
Brand[™]	Identifies a trademark.
<u>Underlined terms</u>	Refer to technical details of the vehicle or indicate technical terms, which are explained in the glossary.

2.1 Unpacking and setting up the vehicle

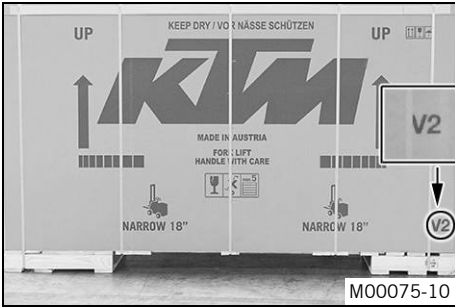

Package 2

- Remove the box and the plastic packaging.



Info

An assistant prevents the motorcycle from falling over. To avoid damaging the motorcycle during the setup, leave the protective film on the vehicle until you have finished.

- Remove the separate enclosure and unpack it. Check that the scope of supply is complete on the basis of the enclosed packing list.
- Have a lift stand available.

Lift stand (78929955100)

- Carefully loosen and remove the tension belt of the footrest bracket.



Info

An assistant prevents the motorcycle from falling over.

- Together with an assistant, take the vehicle off the palette.
- Position the vehicle on a lift stand.
- Check the vehicle for transport damage.

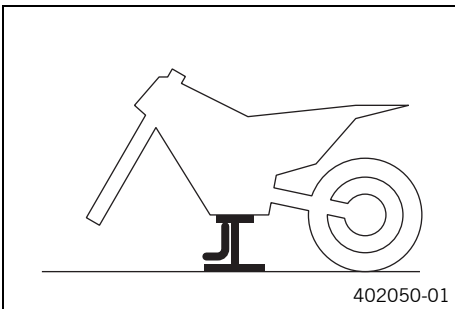

402050-01

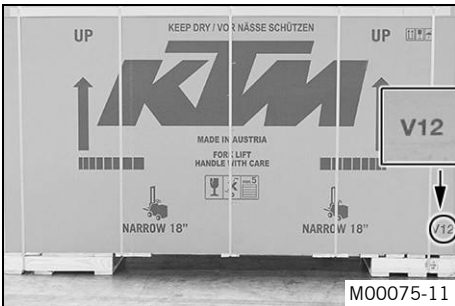

Package 12

- Remove the box and the plastic packaging.



Info

An assistant prevents the motorcycle from falling over. To avoid damaging the motorcycle during the setup, leave the protective film on the vehicle until you have finished.

- Remove the separate enclosure and unpack it. Check that the scope of supply is complete on the basis of the enclosed packing list.
- Have a lift stand available.

Lift stand (78929955100)

- Together with an assistant, take the vehicle off the palette.
- Position the vehicle on a lift stand.
- Check the vehicle for transport damage.
- Install the shock absorber. (☛ p. 7)

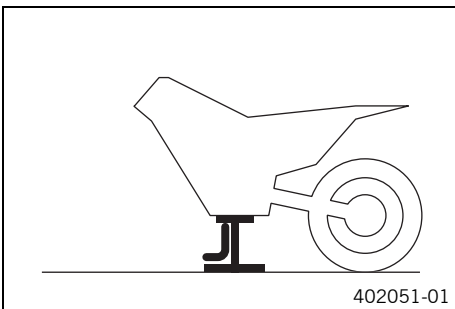

402051-01

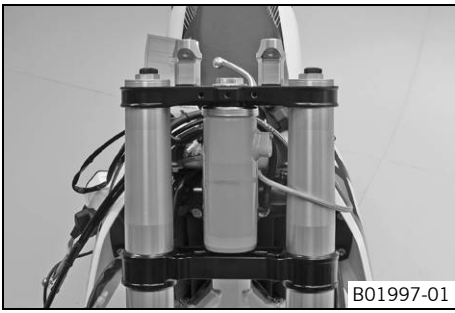

- Route the clutch line with the clutch master cylinder toward the front between the upper and lower triple clamps.
- Position the fork legs and tighten the screws of the triple clamp.

Guideline

Screw, top triple clamp	M8	22 Nm (16.2 lbf ft)
Screw, bottom triple clamp	M8	18 Nm (13.3 lbf ft)

i Info

The upper milled groove in the fork leg must be flush with the upper edge of the upper triple clamp.
Position the bleeder screws toward the front.

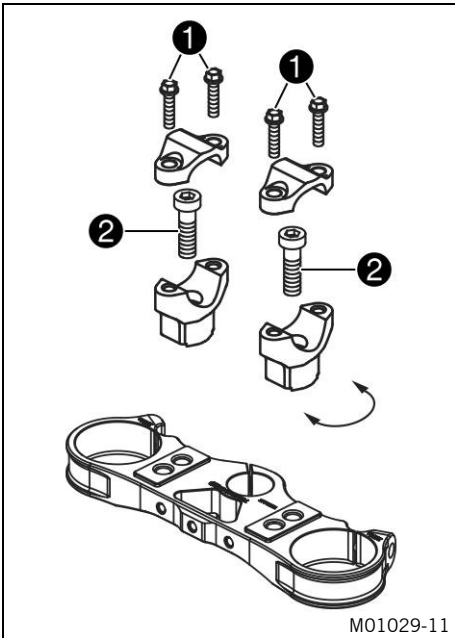

- Remove screws ①. Take off the handlebar clamps.
- Remove screws ②. Take off the handlebar supports.
- Place the handlebar supports in the required position. Mount and tighten screws ②.

Guideline

Screw, handlebar support	M10	40 Nm (29.5 lbf ft)	Loctite® 243™
--------------------------	-----	------------------------	---------------

i Info

Position the left and right handlebar supports evenly.



- Position the handlebar.

i Info

Make sure the cables and wiring are positioned correctly.

- Position the handlebar clamps. Mount and tighten the screws evenly.

Guideline

Screw, handlebar clamp	M8	20 Nm (14.8 lbf ft)
------------------------	----	------------------------

i Info

The markings on the handlebar should be at the center of the handlebar clamps.
Keep the gap widths equal when tightening.

- Install the front wheel. (☛ p. 8)
- Position the controls on the right half of the handlebar.

i Info

The routing of the cables can be seen in the figure.

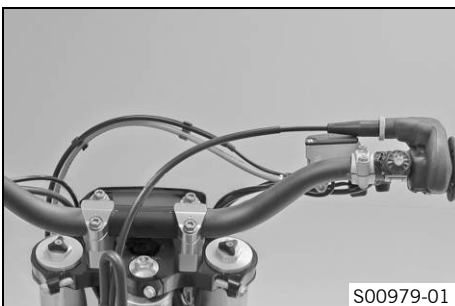

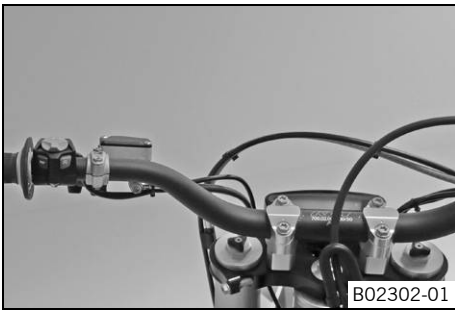

B02302-01

- Position the controls on the left half of the handlebar.

i Info

The figure shows how to route the clutch line and wiring harness.

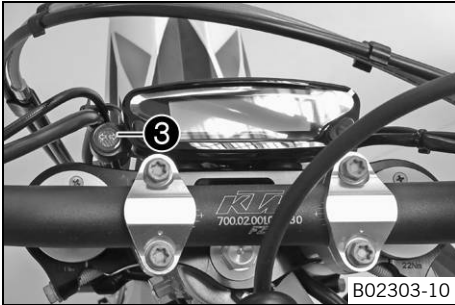

B02303-10

(EU/AU)

- Mount the connector retainer and speedometer on the upper triple clamp.

Guideline

Remaining screws, chassis	M6	10 Nm (7.4 lbf ft)
---------------------------	----	-----------------------

- Position turn signal indicator lamp **3**.
- Connect all plug-in connectors to the connector retainer.

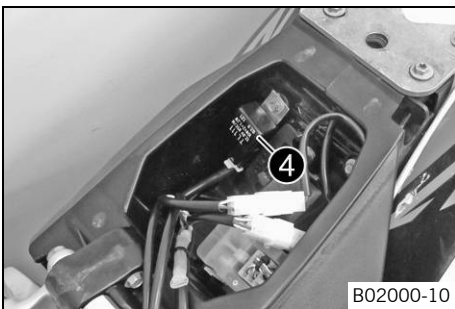

B02000-10

- Remove the fuel tank. (☛ p. 9)
- Disconnect the plug-in connector on the main wiring harness.
- Connect the plug-in connector of the turn signal wiring harness with the plug-in connector of the main wiring harness.
- Mount turn signal relay **4** with the retaining bracket and plug in the connector.



B02006-01

- Position the turn signal wiring harness against the main wiring harness and secure with cable ties.

i Info

The routing of the wiring harness is shown in the figure.

- Install the fuel tank. (☛ p. 10)

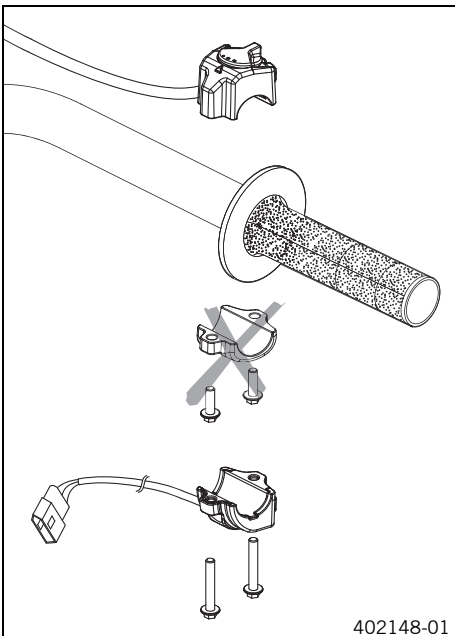

402148-01

- Mount the turn signal switch and connect the plug-in connector on the wiring harness.
- Mount the handlebar cushion.
- Install the front fender. (☛ p. 13)
- Refit the headlight mask with the headlight. (☛ p. 14)

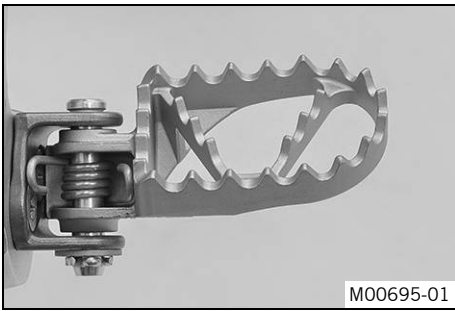

- Mount the footrests with the springs and pins. Secure the pins using the washers and cotter pins.

Pliers for footrest spring (58429083000)



(EU/AU)

- Mount the license plate holder with the license plate lamp, turn signals, and reflector.
- Connect the electrical components.
- Connect the plug-in connector of the right turn signal with the connector marked green on the wiring harness.
- Connect the plug-in connector of the left turn signal with the connector marked red on the wiring harness.



Warning

Risk of injury Batteries contain harmful substances.

- Keep batteries out of the reach of children.
- Keep sparks and open flames away from the battery.
- Only charge in well-ventilated rooms.
- Maintain the minimum clearance to inflammable materials while charging.

Minimum clearance 1 m (3 ft)

- Over-discharged batteries with a charge of less than 9 V are not permitted to be charged. They must be disposed of.

- Recharge the battery. (☛ p. 11)



Info

Read the notes in the battery package.

- Unpack and mount the **KTM PowerParts** included in the delivery (optional).



Info

Read the accompanying **KTM PowerParts** fitting instructions.

- Apply the label included in the delivery (optional).

(EU/AU)

- Mount the mirror clamps on both sides.



- Mount and tighten the rear mirror on both sides.
- Position all controls in their exact positions on the handlebar. Tighten all screws.
- Refuel. (☛ p. 16)
- Prepare the vehicle according to the specifications in the **KTM Dealer.net** for hand-over to the customer.



3.1 Raising the motorcycle with the lift stand

Note

Danger of damage The parked vehicle may roll away or fall over.

- Always place the vehicle on a firm and even surface.

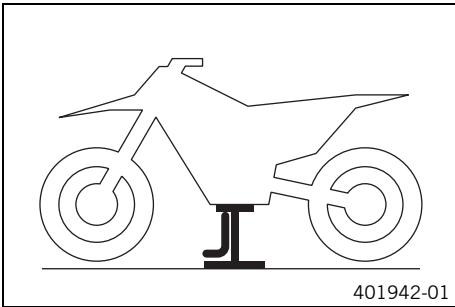

- Raise the motorcycle at the frame underneath the engine.

Lift stand (78929955100)

- ✓ Neither wheel is in contact with the ground.
- Secure the motorcycle against falling over.

3.2 Removing the motorcycle from the lift stand

Note

Danger of damage The parked vehicle may roll away or fall over.

- Always place the vehicle on a firm and even surface.

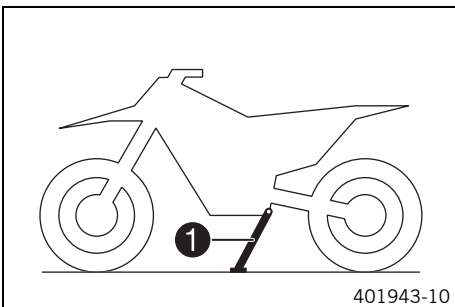

- Remove the motorcycle from the lift stand.
- Remove the lift stand.
- To park the motorcycle, press side stand ① to the ground with your foot and lean the motorcycle on it.

i Info

When you are riding, the side stand must be folded up and secured with the rubber band.

3.3 Removing the shock absorber

Preparatory work

- Raise the motorcycle with the lift stand. (☛ p. 7)
- Fold the seat up. (☛ p. 9)

Main work

- Remove screw ①.
- Remove screw ② and lower the rear wheel with the swing arm as far as possible without blocking the rear wheel. Fix the rear wheel in this position.
- Remove screw ③.
- Push splash protector ④ to the side and remove the shock absorber.

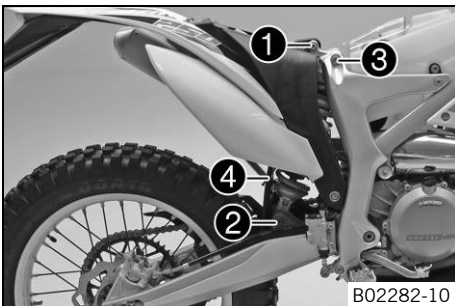

B02282-10

3.4 Installing the shock absorber

Main work

- Push splash protector ① to the side and position the shock absorber. Mount and tighten screw ②.

Guideline

Screw, top shock absorber	M12	80 Nm (59 lbf ft)	Loctite® 2701™
---------------------------	-----	----------------------	----------------

- Mount and tighten screw ③.

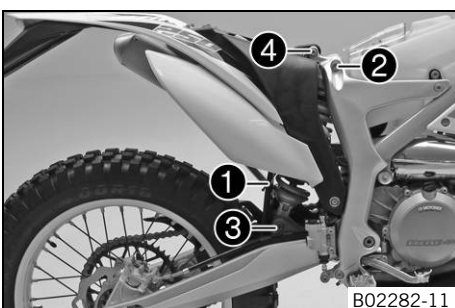

B02282-11

Guideline

Screw, bottom shock absorber	M12	80 Nm (59 lbf ft)	Loctite® 2701™
------------------------------	-----	----------------------	----------------



Info

The heim joint for the shock absorber at the swingarm is Teflon coated. It must not be greased with grease or with any other lubricants. Lubricants dissolve the Teflon coating, thereby drastically reducing the service life.

- Mount and tighten screw ④.

Guideline

Screw, upper subframe	M10	45 Nm (33.2 lbf ft)	Loctite® 243™
-----------------------	-----	------------------------	---------------

Finishing work

- Lock the seat. (☛ p. 9)
- Remove the motorcycle from the lift stand. (☛ p. 7)

3.5 Installing the front wheel



Warning

Danger of accidents Reduced braking efficiency due to oil or grease on the brake discs.

- Always keep the brake discs free of oil and grease, and clean them with brake cleaner when necessary.

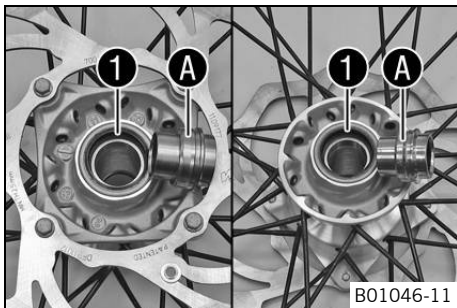

- Check the wheel bearing for damage and wear.
 - » If the wheel bearing is damaged or worn:
 - Change the front wheel bearing.
- Clean and grease the shaft seal rings ① and contact surface ① of the spacers.

Long-life grease (☛ p. 19)

- Insert the spacers.

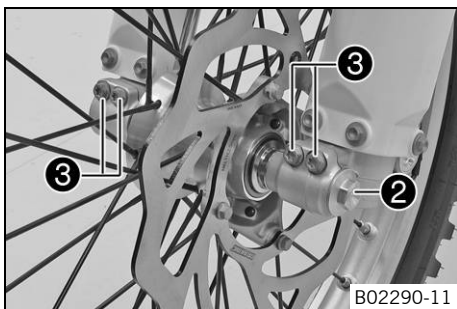

- Position the front wheel and insert the wheel spindle.
 - ✓ The brake linings are correctly positioned.
- Mount and tighten screw ②.

Guideline

Screw, front wheel spindle	M20x1.5	35 Nm (25.8 lbf ft)
----------------------------	---------	------------------------

- Activate the hand brake lever multiple times until the brake linings are in contact with the brake disc.
- Remove the motorcycle from the lift stand. (☛ p. 7)
- Pull the front brake and compress the fork forcefully a few times.
 - ✓ The fork legs straighten.

- Tighten screw ③.

Guideline

Screw, fork stub	M8	15 Nm (11.1 lbf ft)
------------------	----	------------------------

3.6 Folding the seat up

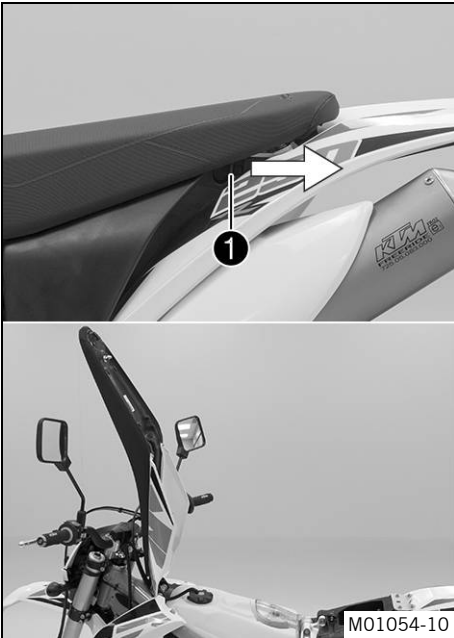

- Push the release lever ❶ in the direction of the arrow.
- Lift the seat and fold it up.

3.7 Locking the seat

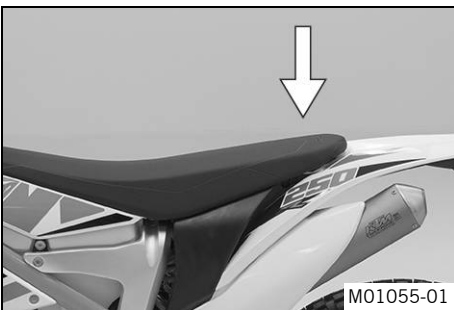

- Fold down the seat and push it down.
 - ✓ The seat engages with an audible click.
- Finally, check that the seat is correctly locked.

3.8 Removing the fuel tank

- Danger**
Fire hazard Fuel is highly flammable.
- Never refuel the vehicle near open flames or burning cigarettes, and always switch off the engine first. Be careful that no fuel is spilt, especially on hot vehicle components. Clean up spilt fuel immediately.
 - The fuel in the fuel tank expands when warm and may emerge if overfilled. Follow the instructions on refueling.

- Warning**
Danger of poisoning Fuel is poisonous and a health hazard.
- Fuel must not come into contact with the skin, eyes, or clothing. Do not breathe in the fuel vapors. If contact occurs with the eyes, rinse with water immediately and contact a physician. Immediately clean contaminated areas on the skin with soap and water. If fuel is swallowed, contact a physician immediately. Change clothing that has been contaminated with fuel. Store fuel properly in a suitable canister and keep away from children.

Preparatory work

- Fold the seat up. (☛ p. 9)

Main work

- Turn handle ❶ of the fuel tap to the **OFF** position.
- Pull off the fuel hose.



Info

Remaining fuel may flow out of the fuel hose.

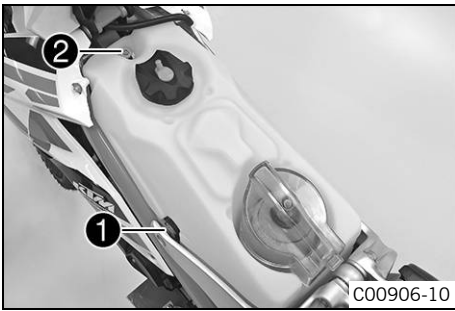

- Remove the tube from the fuel tank breather.
- Remove screws ① on both sides.
- Remove screw ②.

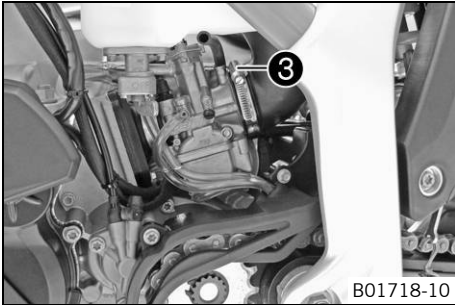

- Release hose clamp ③.
- Detach the intake flange from the carburetor.
- Remove the fuel tank from above.

3.9 Installing the fuel tank

Danger
Fire hazard Fuel is highly flammable.

- Never refuel the vehicle near open flames or burning cigarettes, and always switch off the engine first. Be careful that no fuel is spilt, especially on hot vehicle components. Clean up spilt fuel immediately.
- The fuel in the fuel tank expands when warm and may emerge if overfilled. Follow the instructions on refueling.

Warning
Danger of poisoning Fuel is poisonous and a health hazard.

- Fuel must not come into contact with the skin, eyes, or clothing. Do not breathe in the fuel vapors. If contact occurs with the eyes, rinse with water immediately and contact a physician. Immediately clean contaminated areas on the skin with soap and water. If fuel is swallowed, contact a physician immediately. Change clothing that is contaminated with fuel.

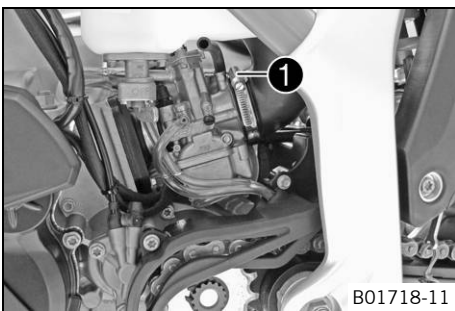

Main work

- Check the throttle cable routing. (☛ p. 11)
- Make sure that the throttle cable or other cables are not trapped or damaged.
- Position the fuel tank.
- Position the intake flange on the carburetor.
- Tighten hose clamp ①.
- Connect the fuel hose.

i Info
 Route the cable and fuel line at a safe distance from the exhaust system.

- Mount and tighten screws ② on both sides.

Guideline

Screw, fuel tank	M8	15 Nm (11.1 lbf ft)	Loctite® 243™
------------------	----	------------------------	---------------

- Mount and tighten screw ③.

Guideline

Remaining screws, chassis	M6	10 Nm (7.4 lbf ft)
---------------------------	----	--------------------

- Mount the fuel tank breather.

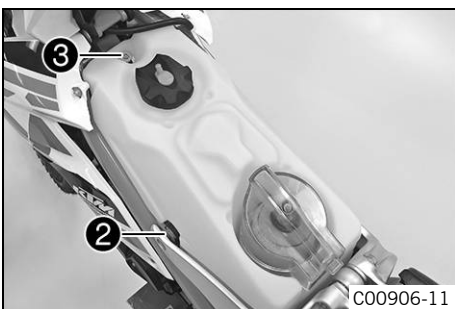

Finishing work

- Lock the seat. (☛ p. 9)

3.10 Checking the throttle cable routing



Preparatory work

- Fold the seat up. (☛ p. 9)
- Remove the fuel tank. (☛ p. 9)

Main work

- Check the throttle cable routing.

The throttle cable must be routed to the carburetor along the back of the handlebar, below the seat fixing.

- » If the throttle cable is not routed as specified:
 - Correct the throttle cable routing.

Finishing work

- Install the fuel tank. (☛ p. 10)
- Lock the seat. (☛ p. 9)

3.11 Recharging the battery



Warning

Risk of injury Batteries contain harmful substances.

- Keep batteries out of the reach of children.
- Keep sparks and open flames away from the battery.
- Only charge in well-ventilated rooms.
- Maintain the minimum clearance to inflammable materials while charging.
Minimum clearance 1 m (3 ft)
- Over-discharged batteries with a charge of less than 9 V are not permitted to be charged. They must be disposed of.



Warning

Environmental hazard The battery contains elements that are harmful to the environment.

- Do not dispose of batteries with the household waste. Dispose of a defective battery in an environmentally friendly manner. Give the battery to your authorized KTM dealer or dispose of it at a collection point for used batteries.



Warning

Environmental hazard Hazardous substances cause environmental damage.

- Oil, grease, filters, fuel, cleaners, brake fluid, etc., should be disposed of as stipulated in applicable regulations.



Info

Even when there is no load on the battery, it discharges steadily. The charge state and the type of charge are very important for the service life of the battery. Rapid recharging with a high charging current shortens the battery's service life. If the charging current, charging voltage and charging time are exceeded, the battery will be destroyed. If the battery is depleted from starting the vehicle repeatedly, the battery must be charged immediately. If the battery is left in a discharged state for an extended period, it will become over-discharged and will be destroyed. The battery is maintenance-free.

Preparatory work

- Raise the motorcycle with the lift stand. (☛ p. 7)



- Fold the seat up. (☛ p. 9)
- Remove the shock absorber. (☛ p. 7)
- Remove the battery. (☛ p. 12)

Main work

- Connect the battery charger with the battery. Switch on the battery charger.

Battery charger (58429074000)

You can also use the battery charger to test the rest potential and starting ability of the battery, and to test the alternator. With this device, you cannot overcharge the battery.



Info

Only charge the battery with the specified battery charge. Read the notes in the battery package.

- Switch off the battery charger after charging and disconnect from the battery.

Guideline

The charging current, charging voltage, and charging time must not be exceeded.

Charge the battery regularly when the motorcycle is not in use	3 months
--	----------

Finishing work

- Install the battery. (☛ p. 13)
- Install the shock absorber. (☛ p. 7)
- Lock the seat. (☛ p. 9)
- Remove the motorcycle from the lift stand. (☛ p. 7)

3.12 Removing the battery



Warning

Risk of injury Batteries contain harmful substances.

- Keep batteries out of the reach of children.
- Keep sparks and open flames away from the battery.
- Only charge in well-ventilated rooms.
- Maintain the minimum clearance to inflammable materials while charging.
Minimum clearance 1 m (3 ft)
- Over-discharged batteries with a charge of less than 9 V are not permitted to be charged. They must be disposed of.

Preparatory work

- Raise the motorcycle with the lift stand. (☛ p. 7)
- Fold the seat up. (☛ p. 9)
- Remove the shock absorber. (☛ p. 7)

Main work

- Remove screw ①.
- Take off fastening plate ②.

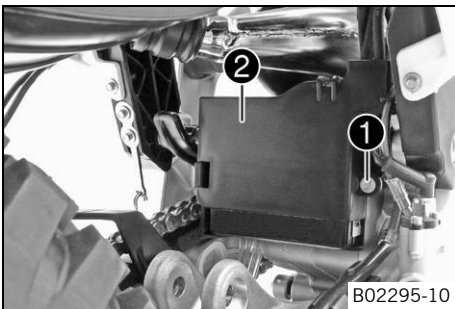

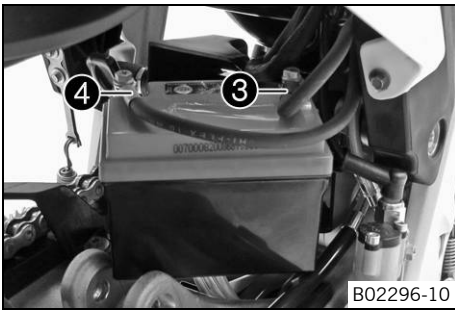

- Remove the battery out of the battery compartment.
- Disconnect negative cable ③ from the battery.
- Disconnect positive cable ④ from the battery.

3.13 Installing the battery

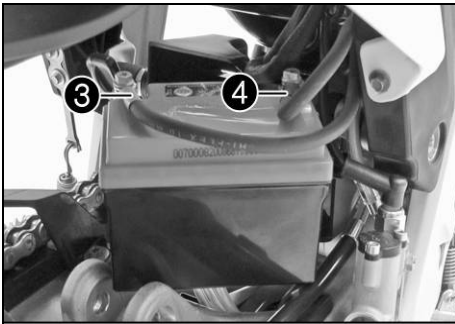

Main work

- Position positive cable ③ and mount and tighten the screw.

Guideline

Screw, battery terminal	M5	2.5 Nm (1.84 lbf ft)
-------------------------	----	-------------------------

- Position negative cable ④ and mount and tighten the screw.

Guideline

Screw, battery terminal	M5	2.5 Nm (1.84 lbf ft)
-------------------------	----	-------------------------

Battery (HJTZ5S-FP)

i Info
Contact disks **A** must be mounted under screws **1** and cable sockets **2** with the claws toward the battery terminal.

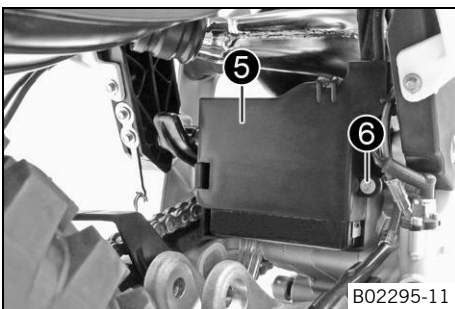
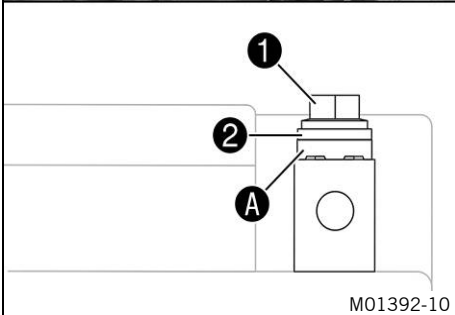

- Position the battery in the battery compartment.

i Info
Ensure that the battery cable is correctly routed.

- Attach fastening plate ⑤.
- Mount and tighten screw ⑥.

Finishing work

- Install the shock absorber. (☛ p. 7)
- Lock the seat. (☛ p. 9)
- Remove the motorcycle from the lift stand. (☛ p. 7)

3.14 Installing the front fender

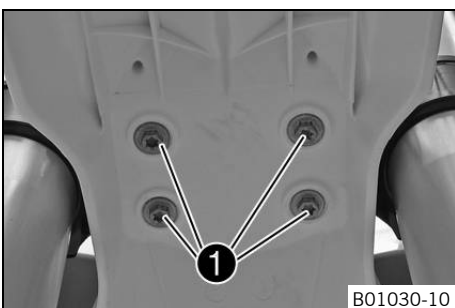

- Position the front fender. Mount and tighten screws ①.

Guideline

Remaining screws, chassis	M6	10 Nm (7.4 lbf ft)
---------------------------	----	--------------------

i Info
Make sure the holding lugs engage in the headlight mask.

3.15 Refitting the headlight mask with the headlight

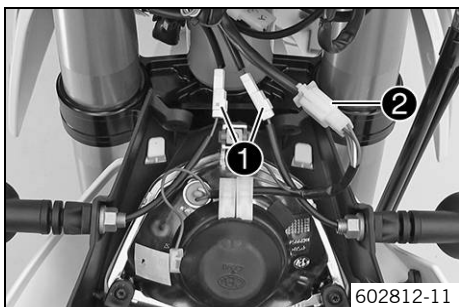

Main work (EU/AU)

- Connect the plug-in connectors **1** for the turn signals and **2** for the headlight.

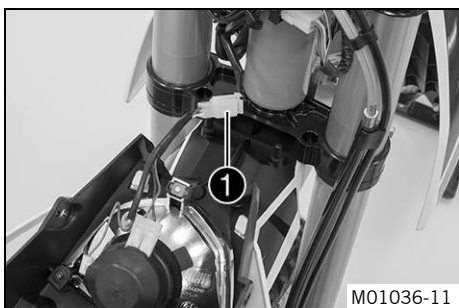

(US)

- Connect plug-in connector **1** of the headlight.

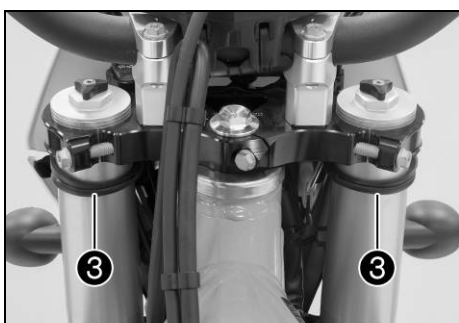

- Position the headlight mask and secure it with rubber straps **3**.
 ✓ The holding lugs on the fender engage in the headlight mask.
- Attach the brake line and wiring harness **4**.



Finishing work

- Check the headlight setting. (☛ p. 14)

3.16 Checking the headlight setting

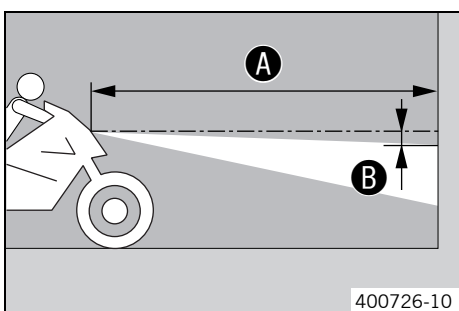

- Position the vehicle upright on a horizontal surface in front of a light wall and make a mark at the height of the center of the low beam headlight.
- Make another mark at a distance **B** under the first mark.

Guideline

Distance B	5 cm (2 in)
-------------------	-------------

- Position the vehicle vertically at a distance **A** away from the wall.

Guideline

Distance A	5 m (16 ft)
-------------------	-------------

- The rider now sits down on the motorcycle.
- Switch on the low beam.
- Check the headlight setting.

The boundary between light and dark must be exactly on the lower mark for a motorcycle with driver.

- » If the boundary between light and dark does not meet specifications:
 - Adjust the headlight range. (☞ p. 15)

3.17 Adjusting the headlight range



Preparatory work

- Check the headlight setting. (☞ p. 14)

Main work

- Adjust the beam distance of the headlight by turning screw ❶.

Guideline

For a motorcycle with rider, the light/dark boundary must be exactly on the lower mark (the mark is created in: Checking the headlight setting).



Info

Turn clockwise to increase the headlight range, turn counterclockwise to reduce the headlight range.
A change in weight on the vehicle may require a correction of the headlight range.

3.18 Opening the filler cap



Danger

Fire hazard Fuel is highly flammable.

- Never refuel the vehicle near open flames or burning cigarettes, and always switch off the engine first. Be careful that no fuel is spilt, especially on hot vehicle components. Clean up spilt fuel immediately.
- The fuel in the fuel tank expands when warm and may emerge if overfilled. Follow the instructions on refueling.



Warning

Danger of poisoning Fuel is poisonous and a health hazard.

- Fuel must not come into contact with the skin, eyes, or clothing. Do not breathe in the fuel vapors. If contact occurs with the eyes, rinse with water immediately and contact a physician. Immediately clean contaminated areas on the skin with soap and water. If fuel is swallowed, contact a physician immediately. Change clothing that has been contaminated with fuel. Store fuel properly in a suitable canister and keep away from children.



Warning

Environmental hazard Improper handling of fuel is a danger to the environment.

- Do not allow fuel to get into the ground water, the ground, or the sewage system.

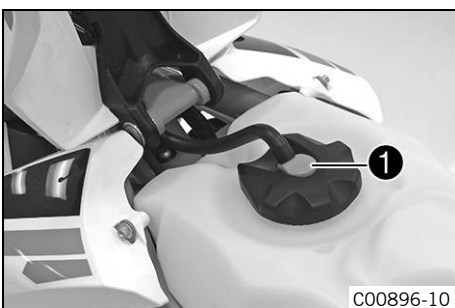

Preparatory work

- Fold the seat up. (☞ p. 9)

Main work

- Press release button ❶, turn the filler cap counterclockwise, and lift it free.

3.19 Closing the filler cap

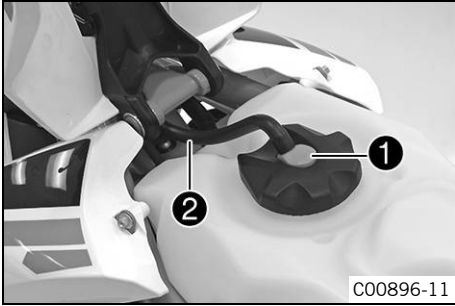

Main work

- Replace the filler cap and turn clockwise until the release button **1** locks in place.

Info

- Run the fuel tank breather hose **2** without kinks.

Finishing work

- Lock the seat. (☞ p. 9)

3.20 Refueling

Danger

Fire hazard Fuel is highly flammable.

- Never refuel the vehicle near open flames or burning cigarettes, and always switch off the engine first. Be careful that no fuel is spilt, especially on hot vehicle components. Clean up spilt fuel immediately.
- The fuel in the fuel tank expands when warm and may emerge if overfilled. Follow the instructions on refueling.

Warning

Danger of poisoning Fuel is poisonous and a health hazard.

- Fuel must not come into contact with the skin, eyes, or clothing. Do not breathe in the fuel vapors. If contact occurs with the eyes, rinse with water immediately and contact a physician. Immediately clean contaminated areas on the skin with soap and water. If fuel is swallowed, contact a physician immediately. Change clothing that is contaminated with fuel.

Note

Material damage Premature clogging of the fuel filter.

- In some countries and regions, the available fuel quality and cleanliness may not be sufficient. This will result in problems with the fuel system.
- Only refuel with clean fuel that meets the specified standards.

Warning

Environmental hazard Improper handling of fuel is a danger to the environment.

- Do not allow fuel to get into the ground water, the ground, or the sewage system.

Preparatory work

- Switch off the engine.
- Fold the seat up. (☞ p. 9)
- Open the filler cap. (☞ p. 15)

Main work

- Fill the fuel tank with fuel up to measurement **A**.

Guideline

Measurement of A	30 mm (1.18 in)	
Total fuel tank capacity, approx.	7.0 l (1.85 US gal)	Super unleaded (95 octane) mixed with 2-stroke engine oil (1:80) (☞ p. 18)

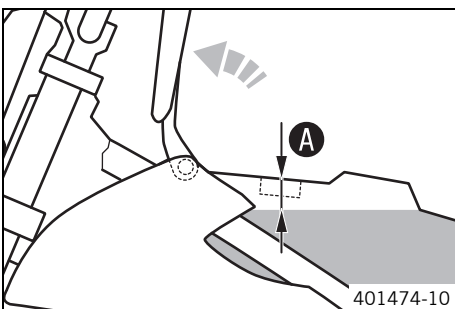

Finishing work

- Close the filler cap. (☞ p. 16)
- Lock the seat. (☞ p. 9)

4.1 Chassis tightening torques

Screw for spoiler, front	EJOT PT® K60x30-Z	3 Nm (2.2 lbf ft)	–
Screw for spoiler, top	EJOT PT® K60x20AL	3 Nm (2.2 lbf ft)	–
Spoke nipple	M4.5	6 Nm (4.4 lbf ft)	–
Screw, battery terminal	M5	2.5 Nm (1.84 lbf ft)	–
Screw, shock absorber adjusting ring	M5	5 Nm (3.7 lbf ft)	–
Nut, cable on starter motor	M6	4 Nm (3 lbf ft)	–
Remaining nuts, chassis	M6	10 Nm (7.4 lbf ft)	–
Remaining screws, chassis	M6	10 Nm (7.4 lbf ft)	–
Screw for spoiler attachment	M6	5 Nm (3.7 lbf ft)	–
Screw, ball joint of push rod on foot brake cylinder	M6	10 Nm (7.4 lbf ft)	Loctite® 243™
Screw, front brake disc	M6	14 Nm (10.3 lbf ft)	Loctite® 243™
Screw, radiator bracket	M6	7 Nm (5.2 lbf ft)	–
Screw, rear brake disc	M6	14 Nm (10.3 lbf ft)	Loctite® 243™
Screws, throttle grip	M6	3 Nm (2.2 lbf ft)	–
Nut, foot brake lever stop	M8	20 Nm (14.8 lbf ft)	–
Nut, rear sprocket screw	M8	35 Nm (25.8 lbf ft)	Loctite® 2701™
Nut, rim lock	M8	10 Nm (7.4 lbf ft)	–
Remaining nuts, chassis	M8	25 Nm (18.4 lbf ft)	–
Remaining screws, chassis	M8	25 Nm (18.4 lbf ft)	–
Screw of rear brake caliper	M8	25 Nm (18.4 lbf ft)	Loctite® 243™
Screw, bottom triple clamp	M8	18 Nm (13.3 lbf ft)	–
Screw, chain sliding piece	M8	15 Nm (11.1 lbf ft)	–
Screw, engine brace on cylinder head	M8	33 Nm (24.3 lbf ft)	–
Screw, engine brace on frame	M8	25 Nm (18.4 lbf ft)	Loctite® 243™
Screw, fork stub	M8	15 Nm (11.1 lbf ft)	–
Screw, front brake caliper	M8	25 Nm (18.4 lbf ft)	Loctite® 243™
Screw, fuel tank	M8	15 Nm (11.1 lbf ft)	Loctite® 243™
Screw, handlebar clamp	M8	20 Nm (14.8 lbf ft)	–
Screw, side stand attachment	M8	25 Nm (18.4 lbf ft)	Loctite® 2701™
Screw, subframe	M8	30 Nm (22.1 lbf ft)	Loctite® 243™
Screw, top steering stem	M8	17 Nm (12.5 lbf ft)	Loctite® 243™
Screw, top triple clamp	M8	22 Nm (16.2 lbf ft)	–
Engine bracket screw	M10	60 Nm (44.3 lbf ft)	–
Nut, fuel tank attachment	M10	10 Nm (7.4 lbf ft)	–
Remaining nuts, chassis	M10	45 Nm (33.2 lbf ft)	–
Remaining screws, chassis	M10	45 Nm (33.2 lbf ft)	–
Screw, battery compartment	M10	45 Nm (33.2 lbf ft)	–
Screw, cross bar	M10	45 Nm (33.2 lbf ft)	–
Screw, foot brake lever	M10	30 Nm (22.1 lbf ft)	Loctite® 243™
Screw, footrest bracket	M10	45 Nm (33.2 lbf ft)	Loctite® 243™
Screw, handlebar support	M10	40 Nm (29.5 lbf ft)	Loctite® 243™
Screw, upper subframe	M10	45 Nm (33.2 lbf ft)	Loctite® 243™
Screw, bottom shock absorber	M12	80 Nm (59 lbf ft)	Loctite® 2701™
Screw, top shock absorber	M12	80 Nm (59 lbf ft)	Loctite® 2701™
Nut, swingarm pivot	M14x1.5	75 Nm (55.3 lbf ft)	–
Nut, rear wheel spindle	M20x1.5	80 Nm (59 lbf ft)	–
Screw, front wheel spindle	M20x1.5	35 Nm (25.8 lbf ft)	–
Screw, top steering head	M20x1.5	12 Nm (8.9 lbf ft)	–

Engine oil, 2-stroke

Standard/classification

- JASO FD (☛ p. 20)

Guideline

- Only use high grade 2-stroke engine oil of a reputable brand.

Fully synthetic

Recommended supplier

Motorex®

- Cross Power 2T

Super unleaded (ROZ 95/RON 95/PON 91)

Standard/classification

- DIN EN 228 (ROZ 95/RON 95/PON 91)

Guideline

- Only use unleaded super fuel that matches or is equivalent to the specified fuel grade.
- Fuel with an ethanol content of up to 10 % (E10 fuel) is safe to use.



Info

Do **not** use fuel containing methanol (e. g. M15, M85, M100) or more than 10 % ethanol (e. g. E15, E25, E85, E100).

Super unleaded (95 octane) mixed with 2-stroke engine oil (1:80)

Standard/classification

- DIN EN 228
- JASO FD (☛ p. 20) (1:80)

Mixture ratio

1:80	Engine oil, 2-stroke (☛ p. 18) Super unleaded (ROZ 95/RON 95/PON 91) (☛ p. 18)
------	---

Recommended supplier

Motorex®

- Cross Power 2T

Long-life grease

Recommended supplier

Motorex®

– Bike Grease 2000

JASO FD

JASO FD is a classification for a 2-stroke engine oil that was specifically developed for the extreme demands of racing. Thanks to first rate synthetic esters and specially designed additives, superb combustion is achieved even under extreme operating conditions.



3213438en

11/2015

