

450 SX-F 450 XC-F

Art. no. 3213447en



KTM

The work described in these setup instructions must be performed before the vehicle is delivered to the customer.

Read the setup instructions in their entirety before beginning work.

These setup instructions were written to correspond to the latest state of this series. We reserve the right to make changes in the interest of technical advancement without at the same time updating this manual.

We shall not provide a description of general workshop methods. Likewise, safety rules that apply in a workshop are not specified here. It is assumed that the work will be performed by a fully trained mechanic.

All specifications are non-binding. KTM Sportmotorcycle GmbH specifically reserves the right to modify or delete technical specifications, prices, colors, forms, materials, services, designs, equipment, etc., without prior notice and without specifying reasons, to adapt these to local conditions, as well as to stop production of a particular model without prior notice. KTM accepts no liability for delivery options, deviations from illustrations and descriptions, misprints, and other errors. The models portrayed partly contain special equipment that does not belong to the regular scope of supply.

© 2015 KTM Sportmotorcycle GmbH, Mattighofen Austria

All rights reserved

Reproduction, even in part, as well as copying of all kinds, is permitted only with the express written permission of the copyright owner.



ISO 9001(12 100 6061)

According to the international quality management standard ISO 9001, KTM uses quality assurance processes that lead to the maximum possible quality of the products.

Issued by: TÜV Management Service

REG.NO. 12 100 6061

KTM Sportmotorcycle GmbH
5230 Mattighofen, Austria

This document is valid for the following models:

450 SX-F EU (F8401P5)

450 SX-F US (F8475P5)

450 XC-F US (F8475P0)



1.1 Symbols used

The meaning of specific symbols is described below.



Indicates an expected reaction (e.g. of a work step or a function).



Indicates an unexpected reaction (e.g. of a work step or a function).



Indicates a page reference (more information is provided on the specified page).



Indicates information with more details or tips.



Indicates the result of a testing step.



Denotes a voltage measurement.



Denotes a current measurement.



Denotes a resistance measurement.

1.2 Formats used

The typographical formats used in this document are explained below.

Proprietary name	Identifies a proprietary name.
Name[®]	Identifies a protected name.
Brand[™]	Identifies a trademark.
<u>Underlined terms</u>	Refer to technical details of the vehicle or indicate technical terms, which are explained in the glossary.

2.1 Unpacking and setting up the vehicle

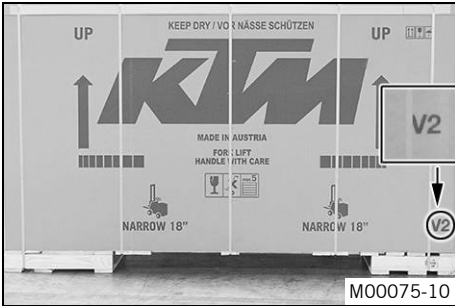

Package 2

- Remove the box and the plastic packaging.

i Info
To avoid damaging the motorcycle during the setup, leave the protective film on the vehicle until you have finished.

- Remove the separate enclosure and unpack it. Check that the scope of supply is complete on the basis of the enclosed packing list.
- Have a lift stand available.

Lift stand (78129955100)

- Carefully loosen and remove the tension belt of the footrest mount.

i Info
An assistant prevents the motorcycle from falling over.

- Together with an assistant, take the vehicle off the palette.
- Position the vehicle on a lift stand.
- Check the vehicle for transport damage.

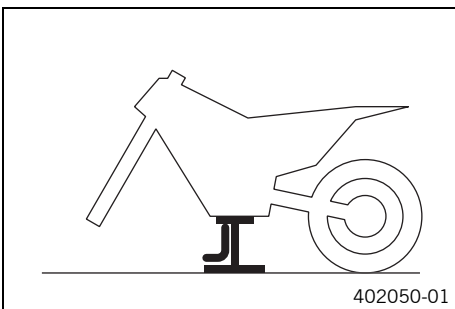

Package 12

- Remove the box and the plastic packaging.

i Info
An assistant prevents the motorcycle from falling over.
To avoid damaging the motorcycle during the setup, leave the protective film on the vehicle until you have finished.

- Remove the separate enclosure and unpack it. Check that the scope of supply is complete on the basis of the enclosed packing list.
- Have a lift stand available.

Lift stand (78129955100)

- Together with an assistant, take the vehicle off the palette.
- Position the vehicle on a lift stand.
- Check the vehicle for transport damage.

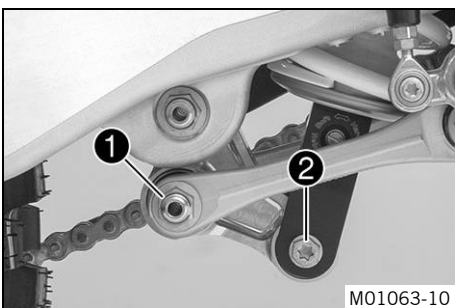
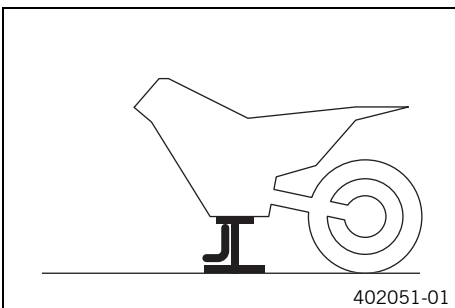
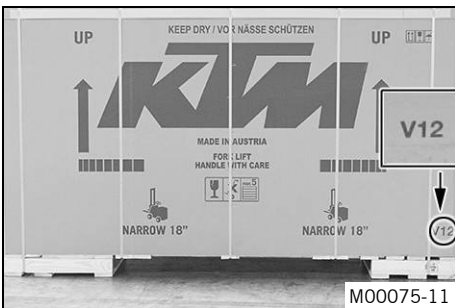

- Remove the cardboard from around the shock absorber.
- Position the angle lever and linkage lever.
- Mount and tighten fitting **1**.

Guideline

Nut, linkage lever to angle lever	M14x1.5	80 Nm (59 lbf ft)
-----------------------------------	---------	-------------------

- Mount and tighten screw **2**.

Guideline

Screw, bottom shock absorber	M10	60 Nm (44.3 lbf ft)	Loctite® 2701™
------------------------------	-----	---------------------	----------------

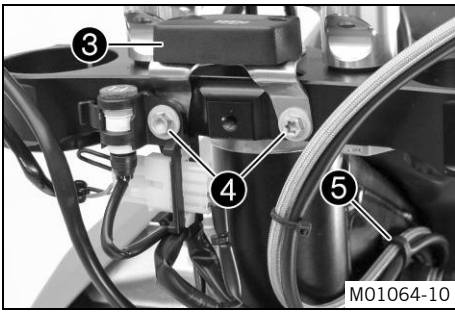

- Connect the plug-in connector for the **FI** warning lamp. Position **FI** warning lamp in the holder.
- Wind the cable for the service hour counter **3** (optional) around the ignition wire as described in the instructions enclosed, and secure using a cable tie.
- Mount the service hour counter (optional) on the holder.
- Position the holder for the **FI** warning lamp and holder for the service hour counter (optional).
- Mount and tighten screws **4**.

Guideline

Remaining screws, chassis	M6	10 Nm (7.4 lbf ft)
---------------------------	----	-----------------------

- Mount cable holder **5** to the frame.
- Route the clutch line with the clutch master cylinder toward the front between the upper and lower triple clamps.

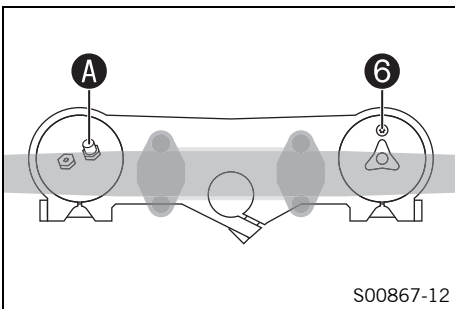

(SX-F EU)

- Position the fork legs.
 - ✓ Bleeder screw **6** of the right fork leg is positioned to the front.
 - ✓ Left fork leg valve **A** is offset by approx. 20° to the front.

i Info

Grooves are milled into the side of the upper end of the fork legs. The second milled groove (from the top) must be flush with the top edge of the upper triple clamp. The air suspension is located in the left fork leg. The pressure and rebound damping is located in the right fork leg.

- Tighten the screws of the triple clamp.

Guideline

Screw, top triple clamp	M8	17 Nm (12.5 lbf ft)
Screw, bottom triple clamp	M8	12 Nm (8.9 lbf ft)

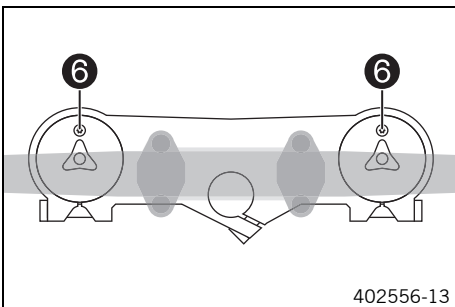

(SX-F US, XC-F US)

- Position the fork legs.
 - ✓ Bleeder screws **6** are positioned toward the front.

i Info

The rebound damping is located in the right fork leg (red adjusting screw). The compression damping is located in the left fork leg (white adjusting screw). Grooves are milled into the side of the upper end of the fork legs. The second milled groove (from the top) must be flush with the top edge of the upper triple clamp.

- Tighten the screws of the triple clamp.

Guideline

Screw, top triple clamp	M8	17 Nm (12.5 lbf ft)
Screw, bottom triple clamp	M8	12 Nm (8.9 lbf ft)

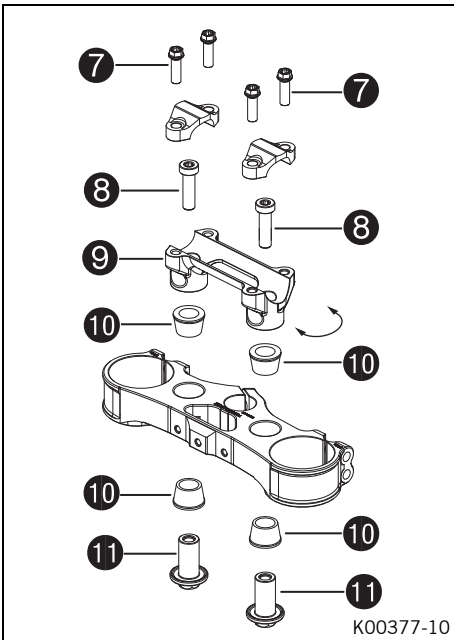

- Remove screws **7**. Take off the handlebar clamps. Remove the handlebar and lay it to one side.

i Info
Cover the components to protect them against damage. Do not kink the cables and lines.

- Remove screws **8**. Remove handlebar support **9**.
- Position rubber bushings **10** and push through nuts **11** from below.
- Place the handlebar support in the required position. Mount and tighten screws **8**.

Guideline

Screw, handlebar support	M10	40 Nm (29.5 lbf ft)	Loctite® 243™
--------------------------	-----	------------------------	---------------

- Position the handlebar.

i Info
Make sure the cables and wiring are positioned correctly.

- Position the handlebar clamps. Mount screws **7**. Screw the handlebar clamps so that both parts touch at the front and tighten all of the screws.

Guideline

Screw, handlebar clamp	M8	20 Nm (14.8 lbf ft)	
------------------------	----	------------------------	--

- Position the controls on the right half of the handlebar.

i Info
The routing of the cables can be seen in the figure.

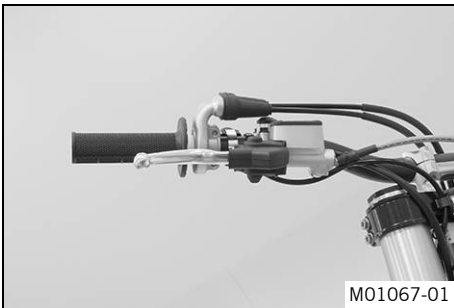

- Position the controls on the left half of the handlebar.

i Info
The figure shows how to route the clutch line and wiring harness.

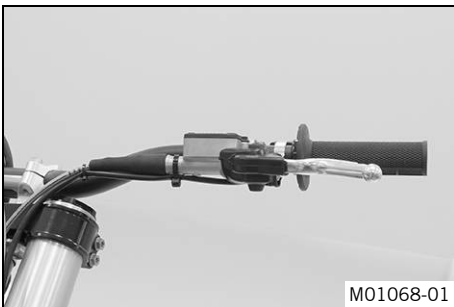

- Install the front fender. (☛ p. 9)
- Install the front wheel. (☛ p. 7)
- Mount the fuel tank breather correctly.

- Mount the handlebar cushion.
- Install the start number plate. (☛ p. 9)
- Install the footrests. (☛ p. 8)
- Recharge the battery. (☛ p. 11)
- Install the battery. (☛ p. 10)
- Unpack and mount the **KTM PowerParts** included in the delivery (optional).

i Info
Read the accompanying **KTM PowerParts** fitting instructions.



- Apply the label included in the delivery (optional).
- Refuel. (☛ p. 14)
- Position all controls in their exact positions on the handlebar. Tighten all screws.

Guideline

Screw, handle bar fixed grip, left	M4	5 Nm (3.7 lbf ft)	Loctite® 243™
------------------------------------	----	----------------------	---------------

- Prepare the vehicle according to the specifications in the **KTM Dealer.net** for handover to the customer.

3.1 Raising the motorcycle with a lift stand

Note

Danger of damage The parked vehicle may roll away or fall over.

- Always place the vehicle on a firm and even surface.

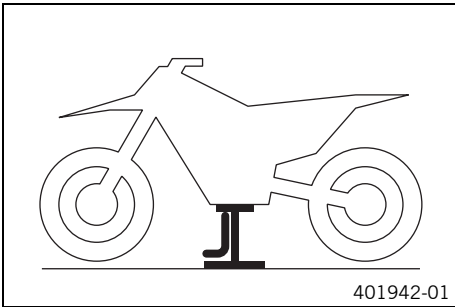

- Raise the motorcycle at the frame underneath the engine.

Lift stand (78129955100)

- ✓ Neither wheel is in contact with the ground.
- Secure the motorcycle against falling over.

3.2 Removing the motorcycle from the lift stand

Note

Danger of damage The parked vehicle may roll away or fall over.

- Always place the vehicle on a firm and even surface.

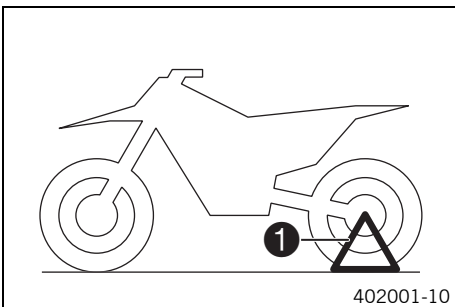

(All SX-F models)

- Remove the motorcycle from the lift stand.
- Remove the lift stand.
- To park the motorcycle, insert plug-in stand ❶ into the left side of the wheel spindle.



Info

Remove the plug-in stand before riding.

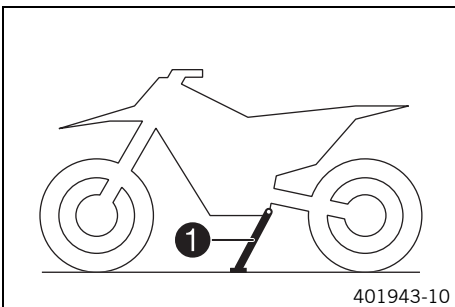

(XC-F US)

- Remove the motorcycle from the lift stand.
- Remove the lift stand.
- To park the motorcycle, press side stand ❶ to the ground with your foot and lean the motorcycle on it.



Info

When you are riding, the side stand must be folded up and secured with the rubber band.

3.3 Installing the front wheel



Warning

Danger of accidents Reduced braking efficiency due to oil or grease on the brake discs.

- Always keep the brake discs free of oil and grease, and clean them with brake cleaner when necessary.

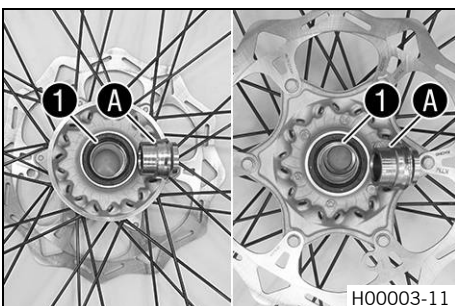

- Check the wheel bearing for damage and wear.
 - » If the wheel bearing is damaged or worn:
 - Change the front wheel bearing.
- Clean and grease shaft seal rings ❶ and bearing surface A of the spacers.

Long-life grease (☛ p. 18)

- Insert the spacers.
- Position the front wheel and insert the wheel spindle.
 - ✓ The brake linings are correctly positioned.

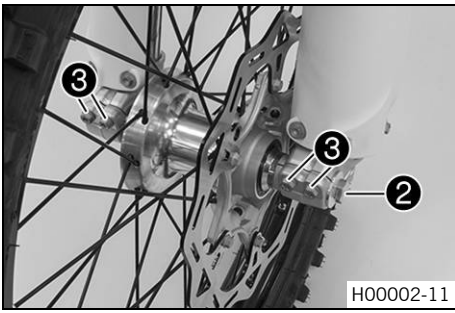

- Mount and tighten screw ②.

Guideline

Screw, front wheel spindle	M20x1.5	35 Nm (25.8 lbf ft)
----------------------------	---------	------------------------

- Operate the hand brake lever several times until the brake linings are lying correctly against the brake disc.
- Remove the motorcycle from the lift stand. (☛ p. 7)
- Operate the front brake and compress the fork a few times firmly.
 - ✓ The fork legs straighten.
- Tighten screws ③.

Guideline

Screw, fork stub	M8	15 Nm (11.1 lbf ft)
------------------	----	------------------------

3.4 Installing the footrests



Info

The procedures are the same on both footrests.

Condition

The frame protectors have been removed on the left and right.

- Position the new footrest and pin.

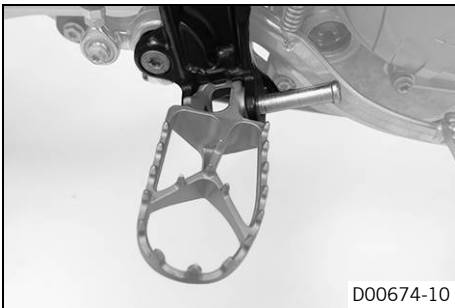

Info

Only insert the pin to the extent that the spring can still be mounted.

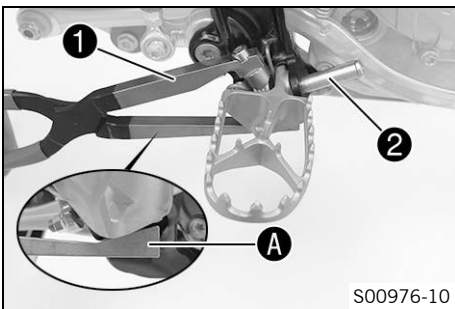

- Press the spring with special tool ①.

Pliers for footrest spring (79029083000)

- ✓ The special tool is applied to area A on the footrest.
- Mount pin ②.

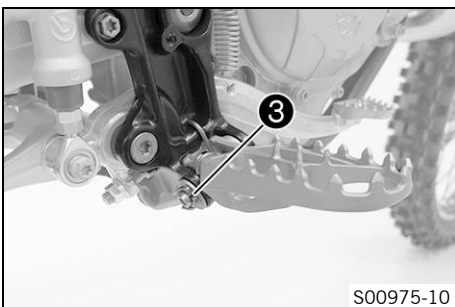

- Mount the washer and split pin ③.

3.5 Installing the front fender

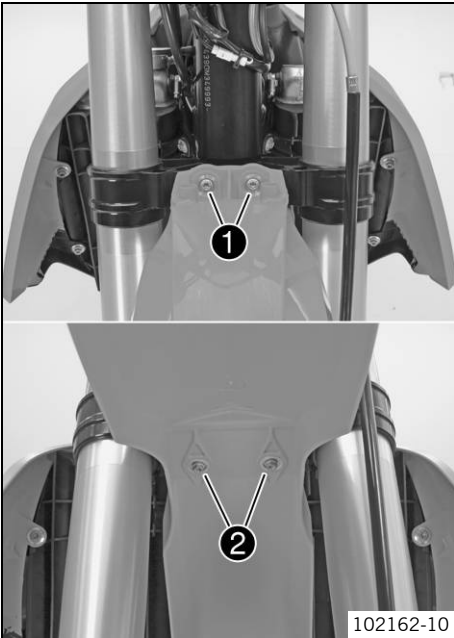

Main work

- Position the front fender. Mount and tighten screws ❶ and ❷.

Guideline

Remaining screws, chassis	M6	10 Nm (7.4 lbf ft)
---------------------------	----	--------------------

Finishing work

- Install the start number plate. (☛ p. 9)

3.6 Installing the start number plate

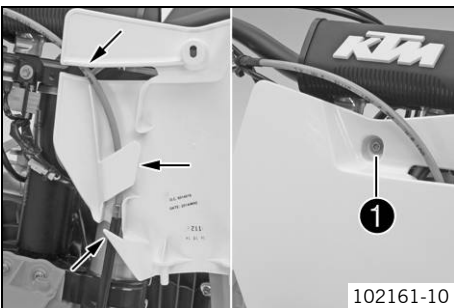

- Attach the start number plate to the brake line.
- Position the start number plate. Mount and tighten screw ❶.

Guideline

Remaining screws, chassis	M6	10 Nm (7.4 lbf ft)
---------------------------	----	--------------------

- ✓ The holding lugs engage in the fender.

3.7 Removing the seat

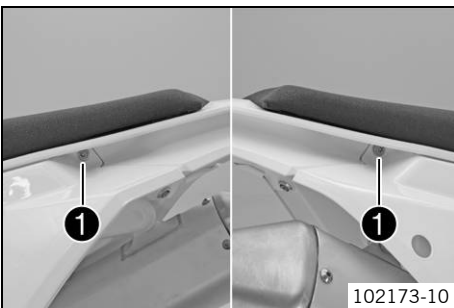

- Remove screws ❶.

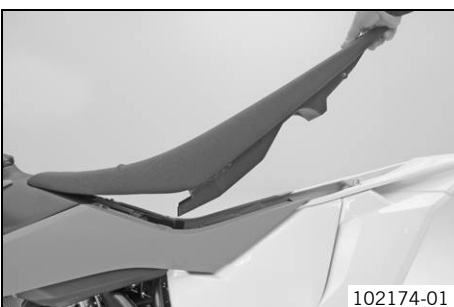

- Raise the rear of the seat, push the seat back, and lift it off.

3.8 Mounting the seat

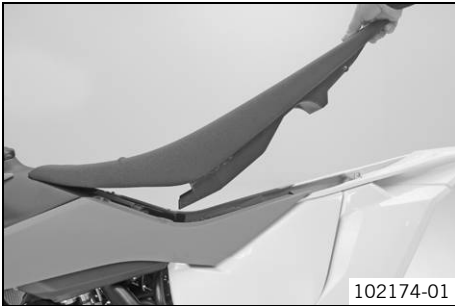

102174-01

- Hook in the front of the seat at the collar bushing of the fuel tank, lower it at the rear and simultaneously push it forward.
- ✓ Seat is correctly latched.

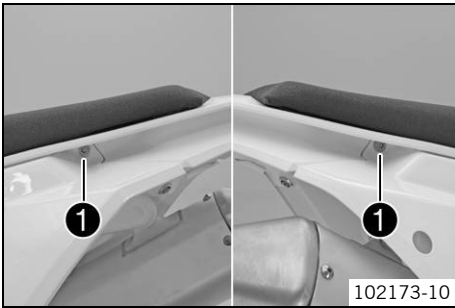

102173-10

- Mount and tighten the seat fixing screws **1**.

Guideline

Remaining screws, chassis	M6	10 Nm (7.4 lbf ft)
---------------------------	----	--------------------

3.9 Installing the battery

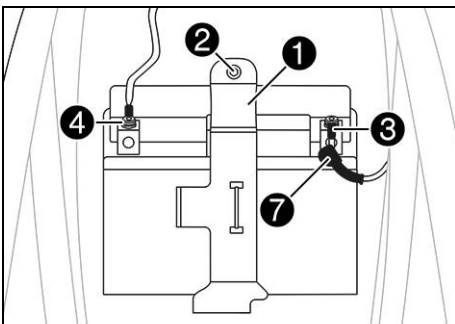

Main work (All SX-F models)

- Insert the battery into the battery compartment with the terminals facing forward and secure with the holding bracket **1**.

Battery (C22S)

- Mount and tighten screw **2**.

Guideline

Remaining nuts, chassis	M6	10 Nm (7.4 lbf ft)
-------------------------	----	-----------------------

- Connect positive cable **3** and negative cable **4** with the battery.

Guideline

Screw, battery terminal	M5	2.5 Nm (1.84 lbf ft)
-------------------------	----	-------------------------

Contact disks **A** must be mounted under screws **5** and cable sockets **6** with the claws toward the battery terminal.

- Slide positive terminal cover **7** over the positive terminal.

H00386-10

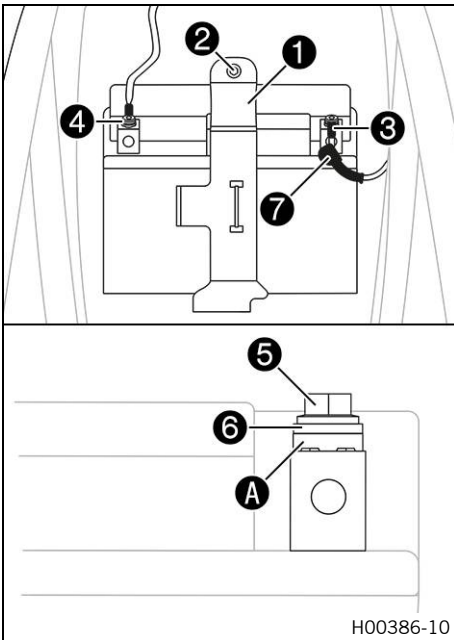

H00386-10

(XC-F US)

- Insert the battery into the battery compartment with the terminals facing forward and secure with the holding bracket **1**.

Battery (HJTZ5S-FP)

- Mount and tighten screw **2**.

Guideline

Remaining nuts, chassis	M6	10 Nm (7.4 lbf ft)
-------------------------	----	-----------------------

- Connect positive cable **3** and negative cable **4** with the battery.

Guideline

Screw, battery terminal	M5	2.5 Nm (1.84 lbf ft)
-------------------------	----	-------------------------

Contact disks **A** must be mounted under screws **5** and cable sockets **6** with the claws toward the battery terminal.

- Slide positive terminal cover **7** over the positive terminal.

Finishing work

- Mount the seat. (☛ p. 10)

3.10 Recharging the battery

Warning
Risk of injury Batteries contain harmful substances.

- Keep batteries out of the reach of children.
- Keep sparks and open flames away from the battery.
- Only charge in well-ventilated rooms.
- Maintain the minimum clearance to inflammable materials while charging.
 Minimum clearance 1 m (3 ft)
- Over-discharged batteries with a charge of less than 9 V are not permitted to be charged. They must be disposed of.

Warning
Environmental hazard The battery contains elements that are harmful to the environment.

- Do not dispose of batteries with the household waste. Dispose of a defective battery in an environmentally friendly manner. Give the battery to your authorized KTM dealer or dispose of it at a collection point for used batteries.

Warning
Environmental hazard Hazardous substances cause environmental damage.

- Oil, grease, filters, fuel, cleaners, brake fluid, etc., should be disposed of as stipulated in applicable regulations.

i Info
 Even when there is no load on the battery, it discharges steadily.
 The charging level and the method of charging are very important for the service life of the battery.
 Rapid recharging with a high charging current shortens the service life of the battery.
 If the charging current, charging voltage, or charging time are exceeded, the battery will be destroyed.
 If the battery is depleted by repeated starting, the battery must be charged immediately.
 If the battery is left in a discharged state for an extended period, it will become over-discharged and sulfated, destroying the battery.
 The battery is maintenance-free.

Preparatory work

- Switch off all power consumers and switch off the engine.
- Remove the seat. (☛ p. 9)
- Remove the battery.



**Main work
(All SX-F models)**

- Check the battery voltage.
 - » Battery voltage: < 9 V
 - Do not charge the battery.
 - Replace the battery and dispose of the old battery properly.
 - » If the specifications have been met:
 - Recharge the battery.

Guideline

The charging current, charging voltage, and charging time must not be exceeded.	
Maximum charging voltage	14.4 V
Maximum charging current	3.0 A
Charge the battery regularly when the motorcycle is not in use	6 months

i Info
Never remove cover ①.

- Connect the battery charger to the battery. Switch on the battery charger.

Battery charger (58429074000)

You can also use the battery charger to test the open-circuit voltage and start potential of the battery, and to test the alternator. With this device, you cannot overcharge the battery. The charging time may be longer at low temperatures.

- Switch off the battery charger after charging and disconnect from the battery.

(XC-F US)

- Check the battery voltage.
 - » Battery voltage: < 9 V
 - Do not charge the battery.
 - Replace the battery and dispose of the old battery properly.
 - » If the specifications have been met:
 - Recharge the battery.

Guideline

The charging current, charging voltage, and charging time must not be exceeded.	
Maximum charging voltage	14.4 V
Maximum charging current	3.0 A
Charge the battery regularly when the motorcycle is not in use	6 months

i Info
Never remove cover ①.

- Connect the battery charger to the battery. Switch on the battery charger.

Battery charger (58429074000)

You can also use the battery charger to test the open-circuit voltage and start potential of the battery, and to test the alternator. With this device, you cannot overcharge the battery. The charging time may be longer at low temperatures.

- Switch off the battery charger after charging and disconnect from the battery.

Finishing work

- Install the battery. (☛ p. 10)
- Mount the seat. (☛ p. 10)



3.11 Opening the filler cap

Danger
Fire hazard Fuel is highly flammable.

- Never refuel the vehicle near open flames or burning cigarettes, and always switch off the engine first. Be careful that no fuel is spilt, especially on hot vehicle components. Clean up spilt fuel immediately.
- The fuel in the fuel tank expands when warm and may emerge if overfilled. Follow the instructions on refueling.

Warning
Danger of poisoning Fuel is poisonous and a health hazard.

- Fuel must not come into contact with the skin, eyes, or clothing. Do not breathe in the fuel vapors. If contact occurs with the eyes, rinse with water immediately and contact a physician. Immediately clean contaminated areas on the skin with soap and water. If fuel is swallowed, contact a physician immediately. Change clothing that has been contaminated with fuel. Store fuel properly in a suitable canister and keep away from children.

Warning
Environmental hazard Improper handling of fuel is a danger to the environment.

- Do not allow fuel to get into the ground water, the ground, or the sewage system.

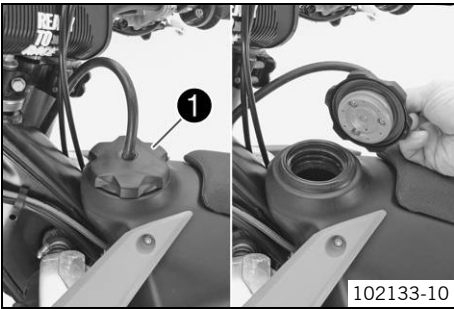

(All SX-F models)

- Turn filler cap ① counterclockwise and lift it off.

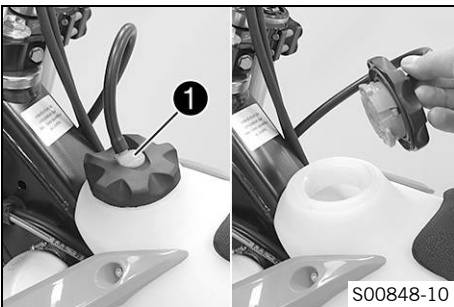

(XC-F US)

- Press release button ①, turn the filler cap counterclockwise, and lift it off.

3.12 Closing the filler cap

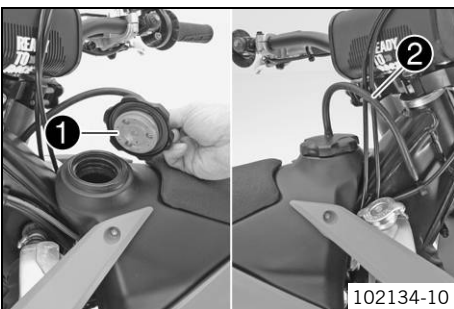

(All SX-F models)

- Mount the filler cap ① and turn it clockwise until the tank is firmly closed.

i Info
 Run the fuel tank breather hose ② without kinks.

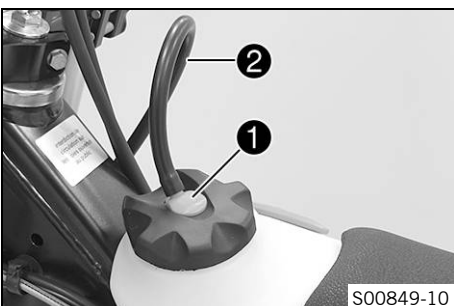

(XC-F US)

- Replace the filler cap and turn clockwise until the release button ① locks in place.

i Info
 Run the fuel tank breather hose ② without kinks.

3.13 Refueling



Danger

Fire hazard Fuel is highly flammable.

- Never refuel the vehicle near open flames or burning cigarettes, and always switch off the engine first. Be careful that no fuel is spilt, especially on hot vehicle components. Clean up spilt fuel immediately.
- The fuel in the fuel tank expands when warm and may emerge if overfilled. Follow the instructions on refueling.



Warning

Danger of poisoning Fuel is poisonous and a health hazard.

- Fuel must not come into contact with the skin, eyes, or clothing. Do not breathe in the fuel vapors. If contact occurs with the eyes, rinse with water immediately and contact a physician. Immediately clean contaminated areas on the skin with soap and water. If fuel is swallowed, contact a physician immediately. Change clothing that is contaminated with fuel.

Note

Material damage Premature clogging of the fuel filter.

- In some countries and regions, the available fuel quality and cleanliness may not be sufficient. This will result in problems with the fuel system.
- Only refuel with clean fuel that meets the specified standards.



Warning

Environmental hazard Improper handling of fuel is a danger to the environment.

- Do not allow fuel to get into the ground water, the ground, or the sewage system.

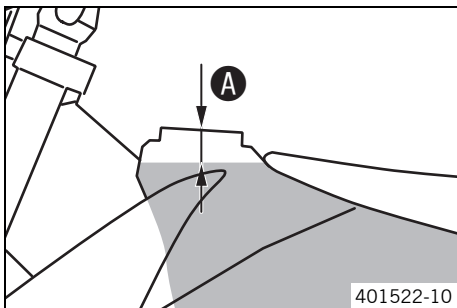

- Switch off the engine.
- Open the filler cap. (☛ p. 13)
- Fill the fuel tank with fuel up to measurement **A**.

Guideline

Measurement of A	35 mm (1.38 in)	
Total fuel tank capacity, approx. (All SX-F models)	7.5 l (1.98 US gal)	Super unleaded (ROZ 95/RON 95/PON 91) (☛ p. 17)
Total fuel tank capacity, approx. (XC-F US)	8.5 l (2.25 US gal)	Super unleaded (ROZ 95/RON 95/PON 91) (☛ p. 17)

- Close the filler cap. (☛ p. 13)

4.1 Chassis tightening torques

Screw air intake temperature sensor	EJOT DELTA PT® 45x12-Z	0.7 Nm (0.52 lbf ft)	–
Screw, air filter box cover	EJOT PT® K60x20-Z	3 Nm (2.2 lbf ft)	–
Screw, pressure regulator	EJOT PT® K60x25-Z	3 Nm (2.2 lbf ft)	–
Screw, handle bar fixed grip, left	M4	5 Nm (3.7 lbf ft)	Loctite® 243™
Spoke nipple, front wheel	M4.5	6 Nm (4.4 lbf ft)	–
Spoke nipple, rear wheel	M4.5	6 Nm (4.4 lbf ft)	–
Remaining nuts, chassis	M5	5 Nm (3.7 lbf ft)	–
Remaining screws, chassis	M5	5 Nm (3.7 lbf ft)	–
Screw, battery terminal	M5	2.5 Nm (1.84 lbf ft)	–
Screw, shock absorber adjusting ring	M5	5 Nm (3.7 lbf ft)	–
Nut, cable on starter motor	M6	4 Nm (3 lbf ft)	–
Remaining nuts, chassis	M6	10 Nm (7.4 lbf ft)	–
Remaining screws, chassis	M6	10 Nm (7.4 lbf ft)	–
Screw, ball joint of push rod on foot brake cylinder	M6	10 Nm (7.4 lbf ft)	Loctite® 243™
Screw, chain sliding guard	M6	6 Nm (4.4 lbf ft)	Loctite® 243™
Screw, front brake disc	M6	14 Nm (10.3 lbf ft)	Loctite® 243™
Screw, rear brake disc	M6	14 Nm (10.3 lbf ft)	Loctite® 243™
Screw, throttle grip	M6	5 Nm (3.7 lbf ft)	–
Fuel connection on fuel tank	M8	10 Nm (7.4 lbf ft)	–
Nut, foot brake lever stop	M8	20 Nm (14.8 lbf ft)	–
Nut, rear sprocket screw	M8	35 Nm (25.8 lbf ft)	Loctite® 2701™
Nut, rim lock	M8	12 Nm (8.9 lbf ft)	–
Remaining nuts, chassis	M8	25 Nm (18.4 lbf ft)	–
Remaining screws, chassis	M8	25 Nm (18.4 lbf ft)	–
Screw manifold on cylinder head brace	M8	25 Nm (18.4 lbf ft)	–
Screw side stand attachment (XC-F US)	M8	35 Nm (25.8 lbf ft)	Loctite® 2701™
Screw, bottom triple clamp	M8	12 Nm (8.9 lbf ft)	–
Screw, chain sliding piece	M8	15 Nm (11.1 lbf ft)	–
Screw, engine brace	M8	25 Nm (18.4 lbf ft)	Loctite® 2701™
Screw, fork stub	M8	15 Nm (11.1 lbf ft)	–
Screw, front brake caliper	M8	25 Nm (18.4 lbf ft)	Loctite® 243™
Screw, handlebar clamp	M8	20 Nm (14.8 lbf ft)	–
Screw, subframe	M8	35 Nm (25.8 lbf ft)	Loctite® 2701™
Screw, top steering stem	M8	20 Nm (14.8 lbf ft)	Loctite® 243™
Screw, top triple clamp	M8	17 Nm (12.5 lbf ft)	–
Engine carrying screw	M10	60 Nm (44.3 lbf ft)	–
Remaining nuts, chassis	M10	45 Nm (33.2 lbf ft)	–
Remaining screws, chassis	M10	45 Nm (33.2 lbf ft)	–
Screw, bottom shock absorber	M10	60 Nm (44.3 lbf ft)	Loctite® 2701™
Screw, handlebar support	M10	40 Nm (29.5 lbf ft)	Loctite® 243™
Screw, top shock absorber	M10	60 Nm (44.3 lbf ft)	Loctite® 2701™
Nut, fuel pump	M12	15 Nm (11.1 lbf ft)	–
Nut, frame to linkage lever	M14x1.5	80 Nm (59 lbf ft)	–
Nut, linkage lever on swingarm	M14x1.5	80 Nm (59 lbf ft)	–
Nut, linkage lever to angle lever	M14x1.5	80 Nm (59 lbf ft)	–
Nut, swingarm pivot	M16x1.5	100 Nm (73.8 lbf ft)	–
Screw, front wheel spindle	M20x1.5	35 Nm (25.8 lbf ft)	–
Screw, top steering head	M20x1.5	12 Nm (8.9 lbf ft)	–
Screw-in nozzles, cooling system	M20x1.5	12 Nm (8.9 lbf ft)	Loctite® 243™

4 TECHNICAL DATA

Nut, rear wheel spindle	M25x1.5	80 Nm (59 lbf ft)	-
-------------------------	---------	-------------------	---

Super unleaded (ROZ 95/RON 95/PON 91)

Standard/classification

- DIN EN 228 (ROZ 95/RON 95/PON 91)

Guideline

- Only use unleaded super fuel that matches or is equivalent to the specified fuel grade.
- Fuel with an ethanol content of up to 10 % (E10 fuel) is safe to use.



Info

Do **not** use fuel containing methanol (e. g. M15, M85, M100) or more than 10 % ethanol (e. g. E15, E25, E85, E100).

Long-life grease

Recommended supplier

Motorex®

– Bike Grease 2000

READY TO RACE

>> www.ktm.com



3213447en

11/2015



KTM

KTM Sportmotorcycle GmbH
5230 Mattighofen/Austria
<http://www.ktm.com>



KTM Group Partner



REG. NO. 12 100 6661

Photo: Mitterbauer/KTM