

## Freeride 350

Art. no. 321345en



**KTM**



The work described in these setup instructions must be performed before the vehicle is delivered to the customer.

Read the setup instructions in their entirety before beginning work.

These setup instructions were written to correspond to the latest state of this series. We reserve the right to make changes in the interest of technical advancement without at the same time updating this manual.

We shall not provide a description of general workshop methods. Likewise, safety rules that apply in a workshop are not specified here. It is assumed that the work will be performed by a fully trained mechanic.

All specifications are non-binding. KTM Sportmotorcycle GmbH specifically reserves the right to modify or delete technical specifications, prices, colors, forms, materials, services, designs, equipment, etc., without prior notice and without specifying reasons, to adapt these to local conditions, as well as to stop production of a particular model without prior notice. KTM accepts no liability for delivery options, deviations from illustrations and descriptions, misprints, and other errors. The models portrayed partly contain special equipment that does not belong to the regular scope of supply.

© 2015 KTM Sportmotorcycle GmbH, Mattighofen Austria

All rights reserved

Reproduction, even in part, as well as copying of all kinds, is permitted only with the express written permission of the copyright owner.



ISO 9001(12 100 6061)

According to the international quality management standard ISO 9001, KTM uses quality assurance processes that lead to the maximum possible quality of the products.

Issued by: TÜV Management Service

REG.NO. 12 100 6061

KTM Sportmotorcycle GmbH  
5230 Mattighofen, Austria

This document is valid for the following models:

Freeride 350 EU (F8203P4)

Freeride 350 AU (F8260P4)



## 1.1 Symbols used

The meaning of specific symbols is described below.



Indicates an expected reaction (e.g. of a work step or a function).



Indicates an unexpected reaction (e.g. of a work step or a function).



Indicates a page reference (more information is provided on the specified page).



Indicates information with more details or tips.



Indicates the result of a testing step.



Denotes a voltage measurement.



Denotes a current measurement.



Denotes a resistance measurement.

## 1.2 Formats used

The typographical formats used in this document are explained below.

<b>Proprietary name</b>	Identifies a proprietary name.
<b>Name<sup>®</sup></b>	Identifies a protected name.
<b>Brand<sup>™</sup></b>	Identifies a trademark.
<b><u>Underlined terms</u></b>	Refer to technical details of the vehicle or indicate technical terms, which are explained in the glossary.

## 2.1 Work rules

Special tools are necessary for certain tasks. The tools are not contained in the vehicle but can be ordered under the number in parentheses. E.g.: bearing puller (15112017000)

During assembly, non-reusable parts (e.g. self-locking screws and nuts, seals and seal rings, O-rings, pins, lock washers) must be replaced by new parts.

In some instances, a thread locker (e.g. **Loctite®**) is required. The manufacturer instructions for use must be followed.

After disassembly, clean the parts that are to be reused and check them for damage and wear. Change damaged or worn parts.

After you complete the repair or service work, check the operating safety of the vehicle.

## 2.2 Safety advice

A number of safety instructions need to be followed to operate the vehicle safely. Therefore, read this manual carefully. The safety instructions are highlighted in the text and are referred to at the relevant passages.

---

 **Info**  
The vehicle has various information and warning labels at prominent locations. Do not remove information/warning labels. If they are missing, you or others may not recognize dangers and may therefore be injured.

---

## 2.3 Degrees of risk and symbols

 **Danger**  
Indicates a danger that will immediately and invariably lead to fatal or serious permanent injury if the appropriate measures are not taken.

 **Warning**  
Indicates a danger that is likely to lead to fatal or serious injury if the appropriate measures are not taken.

**Note**  
Indicates a danger that will lead to considerable machine and material damage if the appropriate measures are not taken.

 **Warning**  
Indicates a danger that will lead to environmental damage if the appropriate measures are not taken.

---

## 2.4 Operating and auxiliary substances

 **Warning**  
**Environmental hazard** Improper handling of fuel is a danger to the environment.  
– Do not allow fuel to get into the ground water, the ground, or the sewage system.

---

Use the operating and auxiliary substances (such as fuel and lubricants) as specified in the manual.

## 3.1 Unpacking and setting up the vehicle

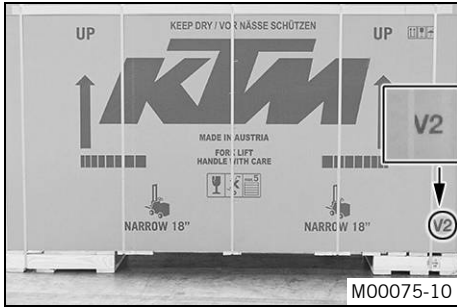

### Package 2

- Remove the box and the plastic packaging.



#### Info

An assistant prevents the motorcycle from falling over. To avoid damaging the motorcycle during the setup, leave the protective film on the vehicle until you have finished.

- Remove the separate enclosure and unpack it. Check that the scope of supply is complete on the basis of the enclosed packing list.
- Have a lift stand available.

Lift stand (78929955100)

- Carefully loosen and remove the tension belt of the footrest bracket.



#### Info

An assistant prevents the motorcycle from falling over.

- Together with an assistant, take the vehicle off the palette.
- Position the vehicle on a lift stand.
- Check the vehicle for transport damage.

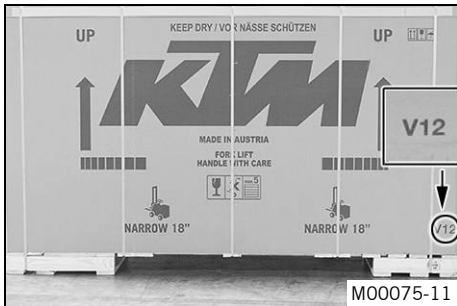
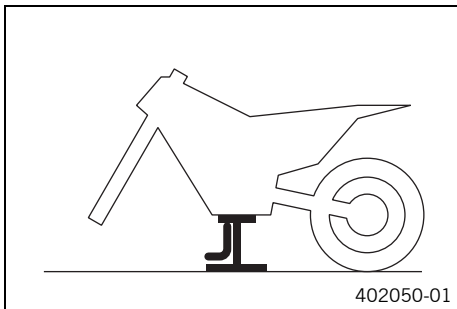

### Package 12

- Remove the box and the plastic packaging.



#### Info

An assistant prevents the motorcycle from falling over. To avoid damaging the motorcycle during the setup, leave the protective film on the vehicle until you have finished.

- Remove the separate enclosure and unpack it. Check that the scope of supply is complete on the basis of the enclosed packing list.
- Have a lift stand available.

Lift stand (78929955100)

- Together with an assistant, take the vehicle off the palette.
- Position the vehicle on a lift stand.
- Check the vehicle for transport damage.
- Install the shock absorber. (☛ p. 9)

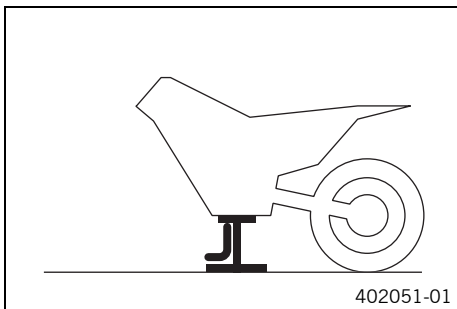

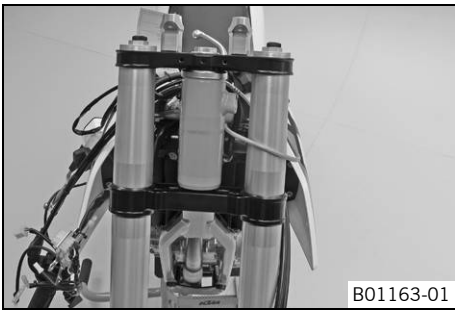

- Route the clutch line with the clutch master cylinder toward the front between the upper and lower triple clamps.
- Position the fork legs and tighten the screws of the triple clamp.

Guideline

Screw, top triple clamp	M8	22 Nm (16.2 lbf ft)
Screw, bottom triple clamp	M8	18 Nm (13.3 lbf ft)

- ✓ Bleeder screws are positioned toward the front.

**i Info**  
The lowest milled groove in the fork leg must be flush with the top edge of the upper triple clamp.

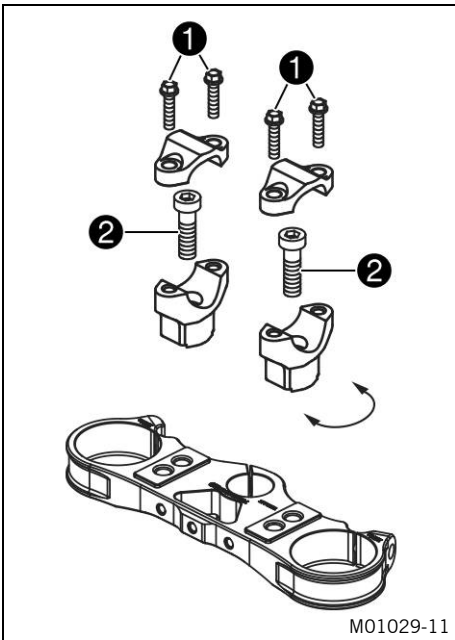

- Remove screws **1**. Take off the handlebar clamps.
- Remove screws **2**. Take off the handlebar supports.
- Place the handlebar supports in the required position. Mount and tighten screws **2**.

Guideline

Screw, handlebar support	M10	40 Nm (29.5 lbf ft)	<b>Loctite® 243™</b>
--------------------------	-----	------------------------	----------------------

**i Info**  
Position the left and right handlebar supports evenly.



- Position the handlebar.

**i Info**  
Make sure the cables and wiring are positioned correctly.

- Position the handlebar clamps. Mount and tighten the screws evenly.

Guideline

Screw, handlebar clamp	M8	20 Nm (14.8 lbf ft)
------------------------	----	------------------------

**i Info**  
The markings on the handlebar should be at the center of the handlebar clamps.  
Keep the gap widths equal when tightening.

- Install the front wheel. (☛ p. 10)
- Mount the handlebar cushion.
- Position the controls on the right half of the handlebar.

**i Info**  
The routing of the cables can be seen in the figure.

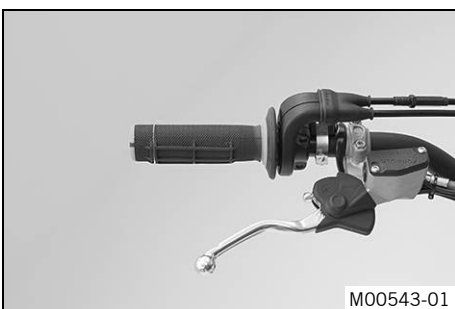

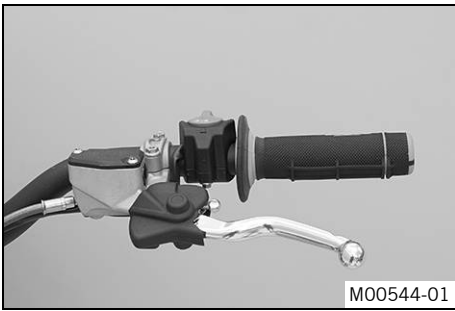

M00544-01

- Position the controls on the left half of the handlebar.



**Info**

The figure shows how to route the clutch line and wiring harness.

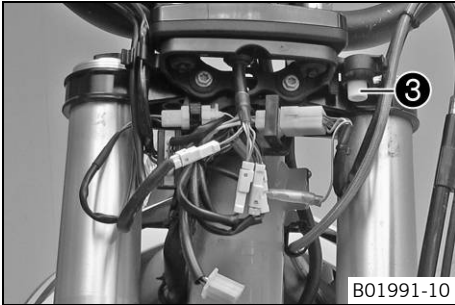

B01991-10

- Mount the connector retainer and speedometer on the upper triple clamp.

**Guideline**

Remaining screws, chassis	M6	10 Nm (7.4 lbf ft)
---------------------------	----	--------------------

- Position turn signal indicator lamp ③.
- Connect all plug-in connectors to the connector retainer.

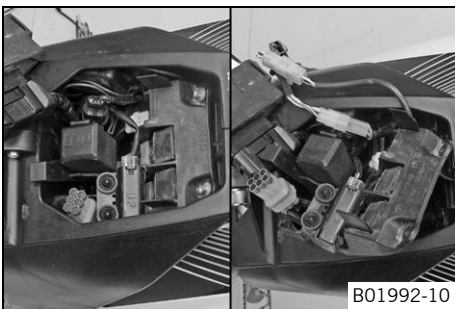

B01992-10

- Remove the fuel tank. (☛ p. 11)
- Pull the EFI control unit from the holder and set it to one side.
- Take off the electrical compartment.
- Disconnect the plug-in connector on the main wiring harness.
- Connect the plug-in connector of the turn signal wiring harness with the plug-in connector of the main wiring harness.

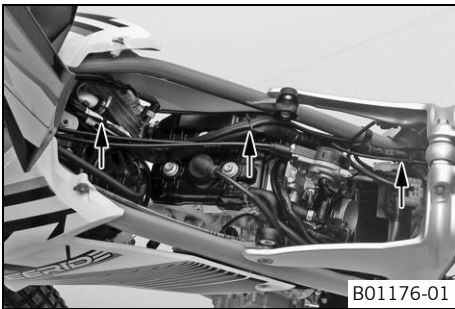

B01176-01

- Position the turn signal wiring harness against the main wiring harness and secure with cable ties.



**Info**

The routing of the wiring harness is shown in the figure.

- Mount the electrical compartment.
- Position the EFI control unit.
- Install the fuel tank. (☛ p. 12)

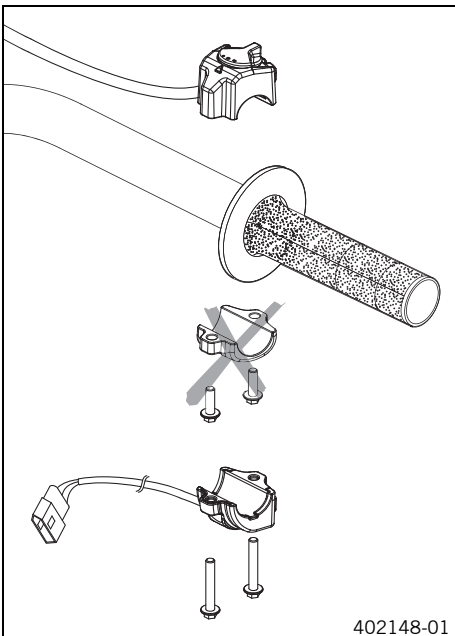

402148-01

- Mount the turn signal switch and connect the plug-in connector on the wiring harness.



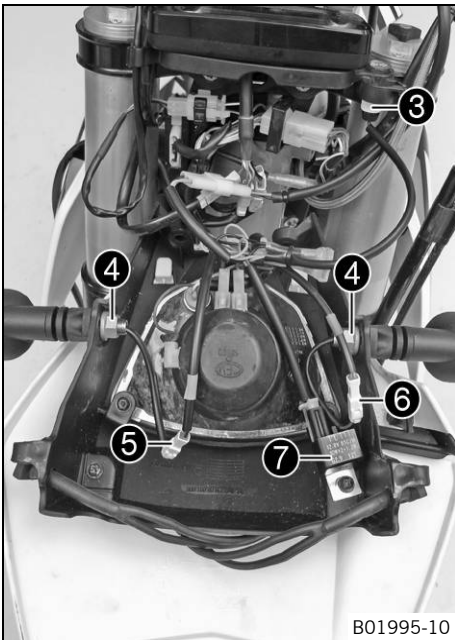

B01995-10

- Insert the black and violet cables of the bulb included in the separate enclosure into the socket and position it in the turn signal indicator lamp ③.
- Position the turn signal on each side and mount and tighten nuts ④.
- Connect the plug-in connector ⑤ of the right turn signal with the connector marked green on the wiring harness.
- Connect plug-in connector ⑥ of the left turn signal with the connector marked red on the wiring harness.
- Mount turn signal relay ⑦ with the retaining bracket and plug in the connector.
- Install the front fender. (☛ p. 16)
- Refit the headlight mask with the headlight. (☛ p. 16)

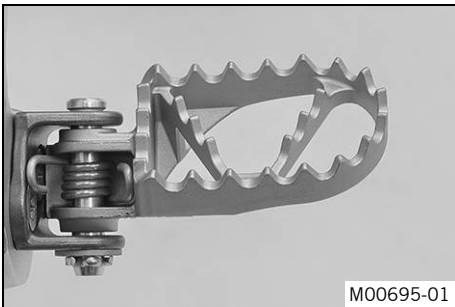

M00695-01

- Mount the footrests with the springs and pins. Secure the pins using the washers and cotter pins.

Pliers for footrest spring (58429083000)



B01170-01

- Mount the license plate holder with the license plate lamp, turn signals, and reflector.
- Connect the electrical components.
- Connect the plug-in connector of the right turn signal with the connector marked green on the wiring harness.
- Connect the plug-in connector of the left turn signal with the connector marked red on the wiring harness.

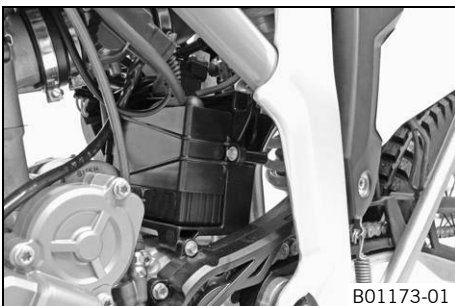

B01173-01



### Warning

**Risk of injury** Battery acid and battery gases cause serious chemical burns.

- Keep batteries out of the reach of children.
- Wear suitable protective clothing and goggles.
- Avoid contact with battery acid and battery gases.
- Keep sparks and open flames away from the battery. Only charge in well-ventilated rooms.
- In the event of skin contact, rinse with large amounts of water. If battery acid gets in the eyes, rinse with water for at least 15 minutes and contact a physician.

- Fill the battery.



### Info

Read the notes in the battery package.

- Recharge the battery. (☛ p. 14)
- Install the battery. (☛ p. 15)
- Unpack and mount the **KTM PowerParts** included in the delivery (optional).



### Info

Read the accompanying **KTM PowerParts** fitting instructions.

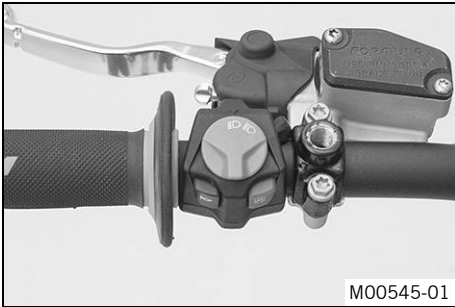

- Apply the label included in the delivery (optional).
- Mount the mirror clamps on both sides.
- Mount and tighten the rear mirror on both sides.
- Position all controls in their exact positions on the handlebar. Tighten all screws.
- Refuel. (☛ p. 18)
- Prepare the vehicle according to the specifications in the **KTM Dealer.net** for hand-over to the customer.

## 4.1 Raising the motorcycle with the lift stand

**Note**

**Danger of damage** The parked vehicle may roll away or fall over.

- Always place the vehicle on a firm and even surface.

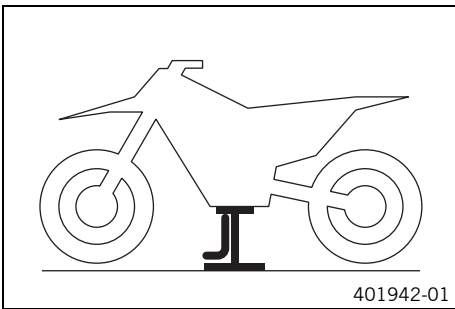

- Raise the motorcycle at the frame underneath the engine.

Lift stand (78929955100)

- ✓ Neither wheel is in contact with the ground.
- Secure the motorcycle against falling over.

## 4.2 Removing the motorcycle from the lift stand

**Note**

**Danger of damage** The parked vehicle may roll away or fall over.

- Always place the vehicle on a firm and even surface.

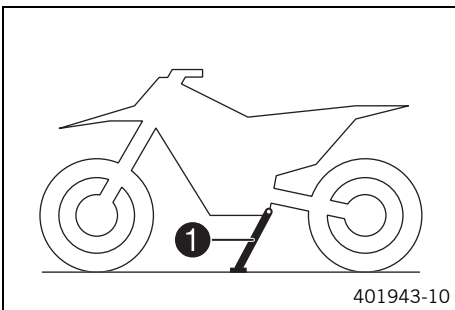

- Remove the motorcycle from the lift stand.
- Remove the lift stand.
- To park the motorcycle, fold side stand ① down to the ground with your foot and rest the motorcycle on it.

**i Info**

While riding, the side stand must be folded up and secured with the rubber band.

## 4.3 Installing the shock absorber

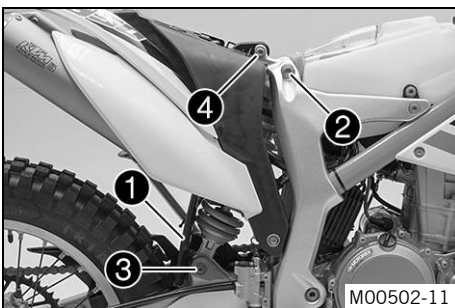

**Main work**

- Push splash protector ① to the side and position the shock absorber. Mount and tighten screw ②.

Guideline

Screw, top shock absorber	M12	80 Nm (59 lbf ft)	Loctite® 2701™
---------------------------	-----	----------------------	----------------

- Mount and tighten screw ③.

Guideline

Screw, bottom shock absorber	M12	80 Nm (59 lbf ft)	Loctite® 2701™
------------------------------	-----	----------------------	----------------

**i Info**

The heim joint for the shock absorber at the swingarm is Teflon coated. It must not be greased with grease or with any other lubricants. Lubricants dissolve the Teflon coating, thereby drastically reducing the service life.

- Mount and tighten screw ④.

Guideline

Screw, upper subframe	M10	45 Nm (33.2 lbf ft)	Loctite® 243™
-----------------------	-----	------------------------	---------------

**Finishing work**

- Lock the seat. (☛ p. 11)
- Remove the motorcycle from the lift stand. (☛ p. 9)

## 4.4 Installing the front wheel



### Warning

**Danger of accidents** Reduced braking efficiency due to oil or grease on the brake discs.

- Always keep the brake discs free of oil and grease, and clean them with brake cleaner when necessary.

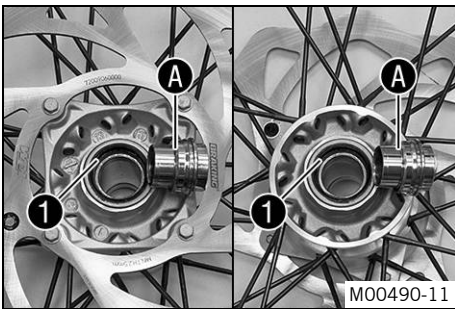

- Check the wheel bearing for damage and wear.
  - » If the wheel bearing is damaged or worn:
    - Change the front wheel bearing.
- Clean and grease the shaft seal rings ① and contact surface A of the spacers.

Long-life grease (☛ p. 23)

- Insert the spacers.

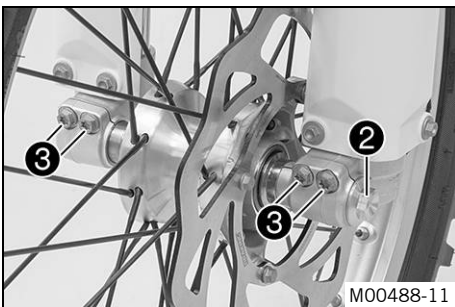

- Position the front wheel and insert the wheel spindle.
  - ✓ The brake linings are correctly positioned.
- Mount and tighten screw ②.

#### Guideline

Screw, front wheel spindle	M20x1.5	35 Nm (25.8 lbf ft)
----------------------------	---------	------------------------

- Activate the hand brake lever multiple times until the brake linings are in contact with the brake disc.
- Remove the motorcycle from the lift stand. (☛ p. 9)
- Pull the front brake and compress the fork forcefully a few times.
  - ✓ The fork legs straighten.
- Tighten screw ③.

#### Guideline

Screw, fork stub	M8	15 Nm (11.1 lbf ft)
------------------	----	------------------------

## 4.5 Folding the seat up

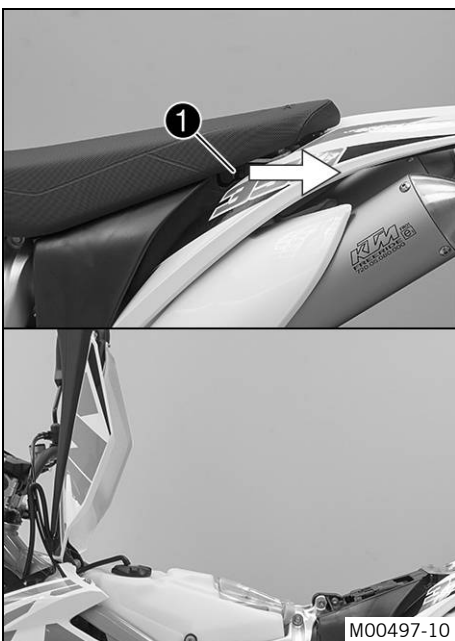

- Press release lever ①.
- Lift the seat and fold it up.

## 4.6 Locking the seat

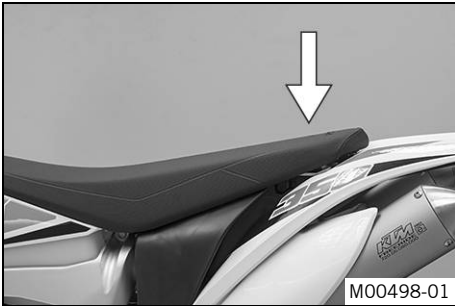

- Fold down the seat and push it down.
- ✓ The seat engages with an audible click.
- Finally, check that the seat is correctly locked.

## 4.7 Removing the fuel tank

**Danger**  
**Fire hazard** Fuel is highly flammable.

- Never refuel the vehicle near open flames or burning cigarettes, and always switch off the engine first. Be careful that no fuel is spilt, especially on hot vehicle components. Clean up spilt fuel immediately.
- The fuel in the fuel tank expands when warm and may emerge if overfilled. Follow the instructions on refueling.

**Warning**  
**Danger of poisoning** Fuel is poisonous and a health hazard.

- Fuel must not come into contact with the skin, eyes, or clothing. Do not breathe in the fuel vapors. If contact occurs with the eyes, rinse with water immediately and contact a physician. Immediately clean contaminated areas on the skin with soap and water. If fuel is swallowed, contact a physician immediately. Change clothing that has been contaminated with fuel. Store fuel properly in a suitable canister and keep away from children.

### Preparatory work

- Fold the seat up. (☞ p. 10)

### Main work

- Thoroughly clean the plug-in connection of the fuel line using compressed air.

**i Info**  
 Under no circumstances should dirt enter the fuel line. Dirt in the fuel line clogs the injection valve.

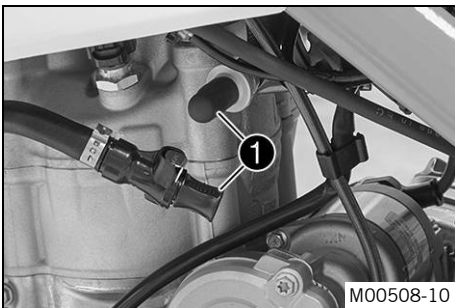

- Disconnect the plug-in connection of the fuel line.
- Mount the wash cap set ①.

Wash cap set (81212016100)

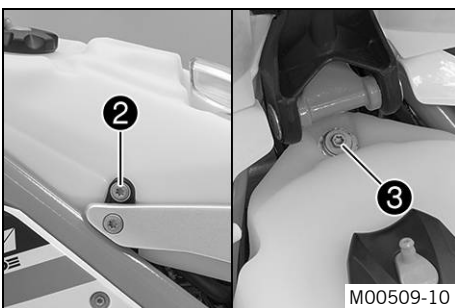

- Remove the tube from the fuel tank breather.
- Remove screws ② on both sides.
- Remove screw ③.

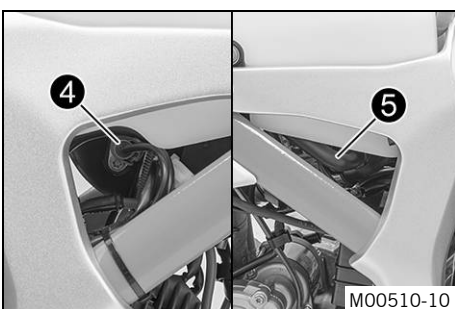

- Unplug connector ④.
- Pull off engine breather hose ⑤.

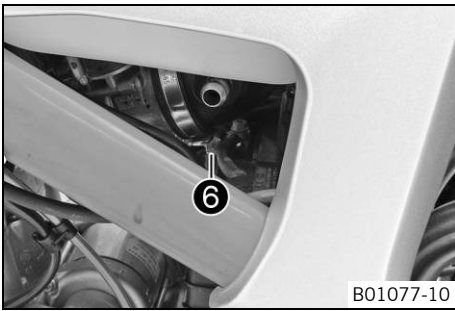

B01077-10

- Release hose clamp ⑥.
- Detach the intake flange from the throttle valve body.

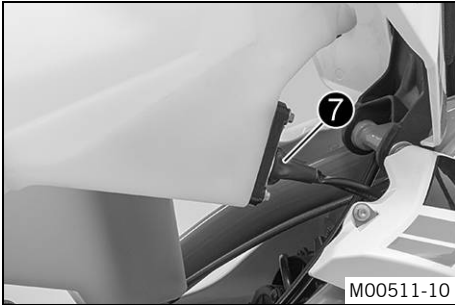

M00511-10

- Pull up the fuel tank slightly and disconnect the connector ⑦ for the fuel pump.
- Remove the fuel tank from above.

## 4.8 Installing the fuel tank



### Danger

**Fire hazard** Fuel is highly flammable.

- Never refuel the vehicle near open flames or burning cigarettes, and always switch off the engine first. Be careful that no fuel is spilt, especially on hot vehicle components. Clean up spilt fuel immediately.
- The fuel in the fuel tank expands when warm and may emerge if overfilled. Follow the instructions on refueling.



### Warning

**Danger of poisoning** Fuel is poisonous and a health hazard.

- Fuel must not come into contact with the skin, eyes, or clothing. Do not breathe in the fuel vapors. If contact occurs with the eyes, rinse with water immediately and contact a physician. Immediately clean contaminated areas on the skin with soap and water. If fuel is swallowed, contact a physician immediately. Change clothing that is contaminated with fuel.



M00511-11

### Main work

- Check the throttle cable routing. (☛ p. 13)
- Make sure that no cables are trapped or damaged.
- Plug in the connector ① for the fuel pump.

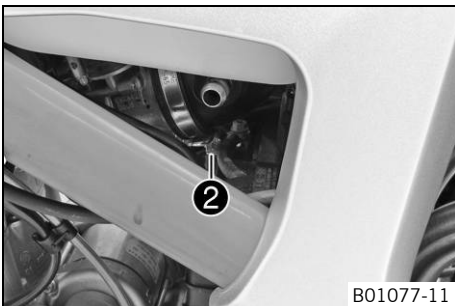

B01077-11

- Position the fuel tank.
- Position the intake flange on the throttle valve body.
- Tighten hose clamp ②.



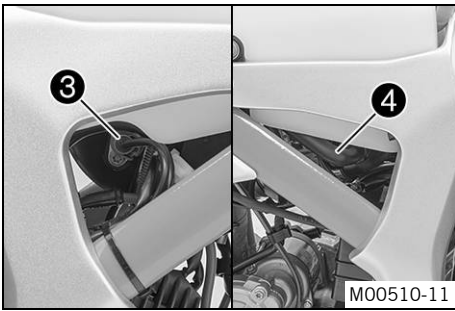

- Plug in connector ③.
- Position engine breather hose ④.

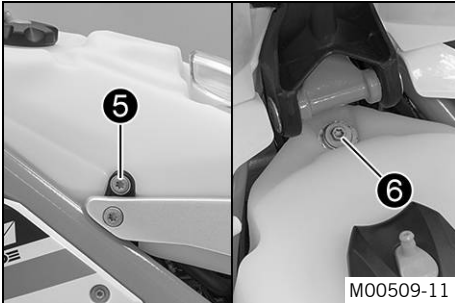

- Mount and tighten screws ⑤ on both sides.

Guideline

Screw, fuel tank	M8	15 Nm (11.1 lbf ft)	Loctite® 243™
------------------	----	------------------------	---------------

- Mount and tighten screw ⑥.

Guideline

Remaining screws, chassis	M6	10 Nm (7.4 lbf ft)
---------------------------	----	--------------------

- Mount the fuel tank breather.
- Thoroughly clean the plug-in connection of the fuel line using compressed air.

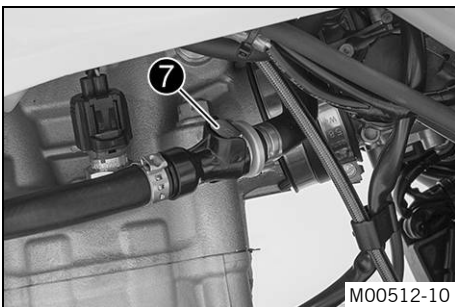

**i Info**

Under no circumstances should dirt enter into the fuel line. Dirt in the fuel line clogs the injection valve.

- Remove the wash cap set. Lubricate the O-ring and connect the plug-in connection ⑦ for the fuel line.

**i Info**

Route the cable and fuel line at a safe distance from the exhaust system.

**Finishing work**

- Lock the seat. (☛ p. 11)

## 4.9 Checking the throttle cable routing

**Preparatory work**

- Fold the seat up. (☛ p. 10)
- Remove the fuel tank. (☛ p. 11)

**Main work**

- Check the throttle cable routing.

Both throttle cables must be routed to the throttle valve body side by side behind the handlebars and below the seat fixing.

- » If the throttle cable is not routed as specified:
  - Correct the throttle cable routing.



**Finishing work**

- Install the fuel tank. (☛ p. 12)
- Lock the seat. (☛ p. 11)

## 4.10 Recharging the battery

- Warning**  
**Risk of injury** Battery acid and battery gases cause serious chemical burns.
- Keep batteries out of the reach of children.
  - Wear suitable protective clothing and goggles.
  - Avoid contact with battery acid and battery gases.
  - Keep sparks and open flames away from the battery. Only charge in well-ventilated rooms.
  - In the event of skin contact, rinse with large amounts of water. If battery acid gets in the eyes, rinse with water for at least 15 minutes and contact a physician.

- Warning**  
**Environmental hazard** The battery contains elements that are harmful to the environment.
- Do not dispose of batteries with the household waste. Dispose of a defective battery in an environmentally friendly manner. Give the battery to your authorized KTM dealer or dispose of it at a collection point for used batteries.

- Warning**  
**Environmental hazard** Hazardous substances cause environmental damage.
- Oil, grease, filters, fuel, cleaners, brake fluid, etc., should be disposed of as stipulated in applicable regulations.

**i Info**  
 Even when there is no load on the battery, it discharges steadily.  
 The charge state and the type of charge are very important for the service life of the battery.  
 Rapid recharging with a high charging current shortens the battery's service life.  
 If the charging current, charging voltage, and charging time are exceeded, electrolyte escapes through the safety valves. This reduces the battery capacity.  
 If the battery is depleted from starting the vehicle repeatedly, the battery must be charged immediately.  
 If the battery is left in a discharged state for an extended period, it will become over-discharged and sulfate, destroying the battery.  
 The battery is maintenance-free, i.e., the acid level does not have to be checked.



- Preparatory work**
- Remove the battery. (☛ p. 15)

- Main work**
- Connect the battery charger to the battery. Switch on the battery charger.

Battery charger (58429074000)

You can also use the battery charger to test the rest potential and starting ability of the battery, and to test the alternator. With this device, you cannot overcharge the battery.

- i Info**  
 Never remove lid **1**.  
 Charge the battery with a maximum of 10% of the capacity specified on the battery housing **2**.

- Switch off the battery charger after charging. Disconnect the battery charger from the battery.

Guideline

The charging current, charging voltage, and charging time must not be exceeded.

Charge the battery regularly when the motorcycle is not in use	3 months
--	----------

- Finishing work**
- Install the battery. (☛ p. 15)



## 4.11 Removing the battery

- Warning**  
**Risk of injury** Battery acid and battery gases cause serious chemical burns.
- Keep batteries out of the reach of children.
  - Wear suitable protective clothing and goggles.
  - Avoid contact with battery acid and battery gases.
  - Keep sparks and open flames away from the battery. Only charge in well-ventilated rooms.
  - In the event of skin contact, rinse with large amounts of water. If battery acid gets in the eyes, rinse with water for at least 15 minutes and contact a physician.

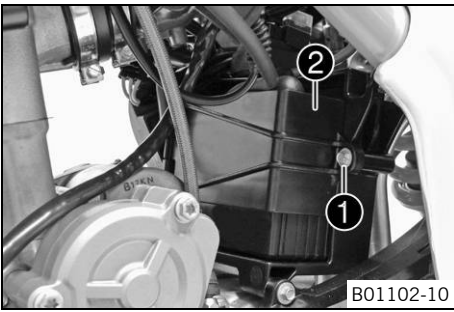

- Switch off all power consumers and switch off the engine.
- Remove screw ①.
- Remove fastening plate ②.

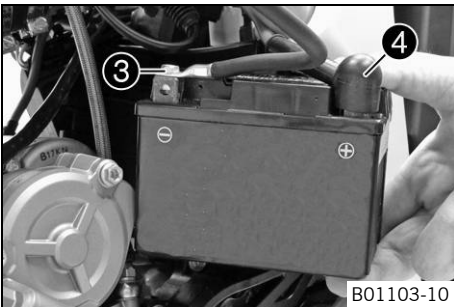

- Remove the battery from the battery compartment.
- Disconnect negative cable ③ from the battery.
- Pull back positive terminal cover ④ and disconnect the positive cable from the battery.

## 4.12 Installing the battery

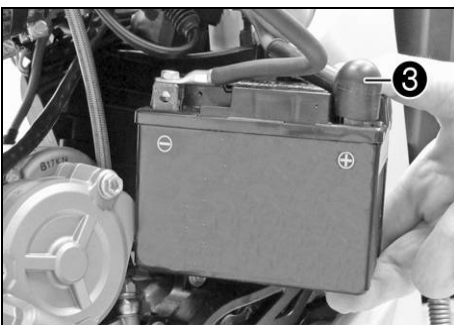

- Position the positive cable and mount and tighten the screw.

Guideline

Screw, battery terminal	M5	2.5 Nm (1.84 lbf ft)
-------------------------	----	-------------------------

**i Info**  
 Contact disks **A** must be mounted under screws ① and cable sockets ② with the claws toward the battery terminal.

- Slide positive terminal cover ③ over the positive terminal.
- Position the negative cable and mount and tighten the screw.

Guideline

Screw, battery terminal	M5	2.5 Nm (1.84 lbf ft)
-------------------------	----	-------------------------

Battery (YTX5L-BS)
--------------------

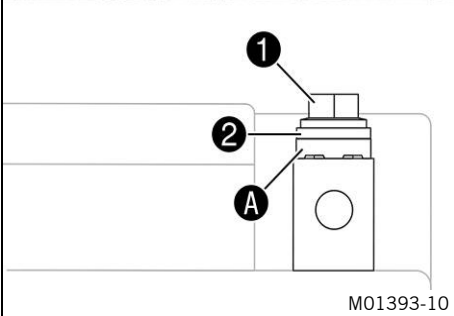

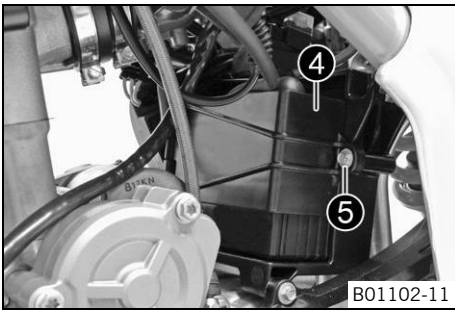

- Position the battery in the battery compartment.
- Attach fastening plate ④.
- Mount and tighten screw ⑤.

## 4.13 Installing the front fender

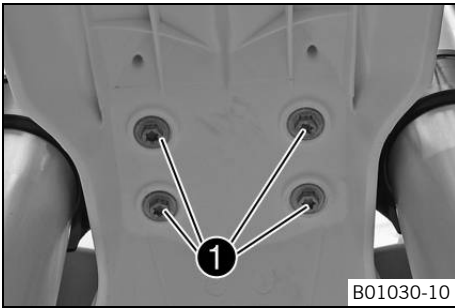

- Position the front fender. Mount and tighten screws ①.

Guideline

Remaining screws, chassis	M6	10 Nm (7.4 lbf ft)
---------------------------	----	--------------------

**i Info**  
Make sure the holding lugs engage in the headlight mask.

## 4.14 Refitting the headlight mask with the headlight

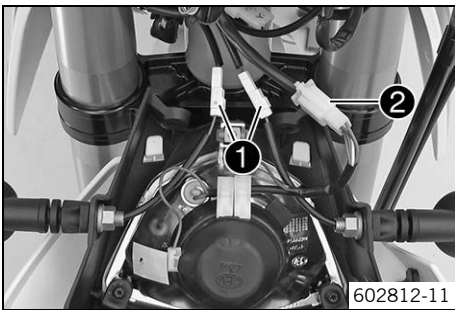

**Main work**

- Connect the plug-in connectors ① for the turn signals and ② for the headlight.

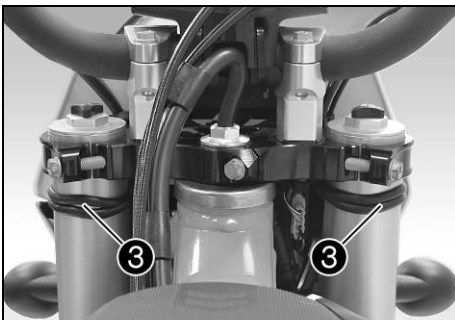

- Position the headlight mask and secure it with rubber bands ③.
- ✓ The holding lugs on the fender engage in the headlight mask.
- Attach the brake line and wiring harness ④.



**Finishing work**

- Check the headlight setting. (☛ p. 17)

## 4.15 Checking the headlight setting

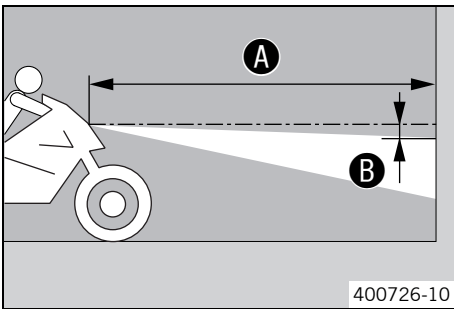

- Position the vehicle upright on a horizontal surface in front of a light wall and make a mark at the height of the center of the low beam headlight.
- Make another mark at a distance **B** under the first mark.

Guideline

Distance <b>B</b>	5 cm (2 in)
-------------------	-------------

- Position the vehicle vertically at a distance **A** away from the wall.

Guideline

Distance <b>A</b>	5 m (16 ft)
-------------------	-------------

- The rider now sits down on the motorcycle.
- Switch on the low beam.
- Check the headlight setting.

The boundary between light and dark must be exactly on the lower mark for a motorcycle with driver.

- » If the boundary between light and dark does not meet specifications:
  - Adjust the headlight range. (☛ p. 17)

## 4.16 Adjusting the headlight range



### Preparatory work

- Check the headlight setting. (☛ p. 17)

### Main work

- Adjust the beam distance of the headlight by turning screw **1**.

Guideline

For a motorcycle with rider, the light/dark boundary must be exactly on the lower mark (the mark is created in: Checking the headlight setting).



### Info

Turn clockwise to increase the headlight range, turn counterclockwise to reduce the headlight range.  
A change in weight on the vehicle may require a correction of the headlight range.

## 4.17 Opening the filler cap



### Danger

**Fire hazard** Fuel is highly flammable.

- Never refuel the vehicle near open flames or burning cigarettes, and always switch off the engine first. Be careful that no fuel is spilt, especially on hot vehicle components. Clean up spilt fuel immediately.
- The fuel in the fuel tank expands when warm and may emerge if overfilled. Follow the instructions on refueling.



### Warning

**Danger of poisoning** Fuel is poisonous and a health hazard.

- Fuel must not come into contact with the skin, eyes, or clothing. Do not breathe in the fuel vapors. If contact occurs with the eyes, rinse with water immediately and contact a physician. Immediately clean contaminated areas on the skin with soap and water. If fuel is swallowed, contact a physician immediately. Change clothing that has been contaminated with fuel. Store fuel properly in a suitable canister and keep away from children.



### Warning

**Environmental hazard** Improper handling of fuel is a danger to the environment.

- Do not allow fuel to get into the ground water, the ground, or the sewage system.

### Preparatory work

- Fold the seat up. (☛ p. 10)

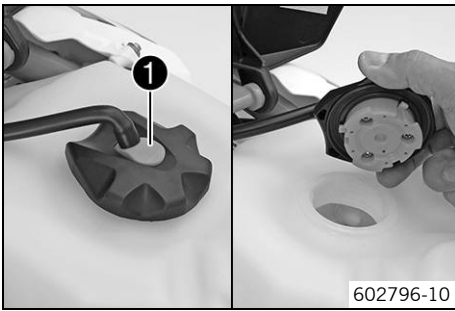

**Main work**

- Press release button ①, turn the filler cap counterclockwise, and lift it free.

## 4.18 Closing the filler cap

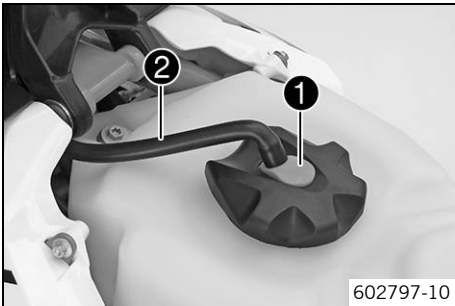

**Main work**

- Replace the filler cap and turn clockwise until the release button ① locks in place.

**Info**

Run the fuel tank breather hose ② without kinks.

**Finishing work**

- Lock the seat. (☛ p. 11)

## 4.19 Refueling



**Danger**

**Fire hazard** Fuel is highly flammable.

- Never refuel the vehicle near open flames or burning cigarettes, and always switch off the engine first. Be careful that no fuel is spilt, especially on hot vehicle components. Clean up spilt fuel immediately.
- The fuel in the fuel tank expands when warm and may emerge if overfilled. Follow the instructions on refueling.



**Warning**

**Danger of poisoning** Fuel is poisonous and a health hazard.

- Fuel must not come into contact with the skin, eyes, or clothing. Do not breathe in the fuel vapors. If contact occurs with the eyes, rinse with water immediately and contact a physician. Immediately clean contaminated areas on the skin with soap and water. If fuel is swallowed, contact a physician immediately. Change clothing that is contaminated with fuel.

**Note**

**Material damage** Premature clogging of the fuel filter.

- In some countries and regions, the available fuel quality and cleanliness may not be sufficient. This will result in problems with the fuel system.
- Only refuel with clean fuel that meets the specified standards.



**Warning**

**Environmental hazard** Improper handling of fuel is a danger to the environment.

- Do not allow fuel to get into the ground water, the ground, or the sewage system.

**Preparatory work**

- Switch off the engine.
- Fold the seat up. (☛ p. 10)
- Open the filler cap. (☛ p. 17)

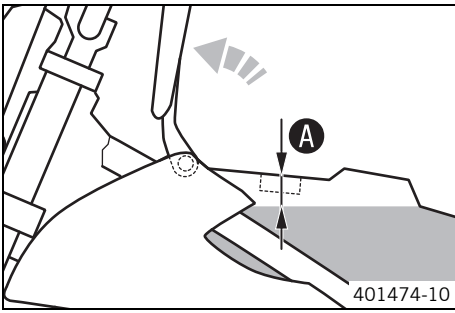

### Main work

- Fill the fuel tank with fuel up to measurement **A**.

### Guideline

Measurement of <b>A</b>	30 mm (1.18 in)	
Total fuel tank capacity, approx.	5.5 l (1.45 US gal)	Super unleaded (ROZ 95/RON 95/PON 91) (☛ p. 22)

### Finishing work

- Close the filler cap. (☛ p. 18)
- Lock the seat. (☛ p. 11)

## 5.1 Chassis tightening torques

Screw for spoiler, front	EJOT PT® K60x30-Z	3 Nm (2.2 lbf ft)	–
Screw for spoiler, top	EJOT PT® K60x20AL	3 Nm (2.2 lbf ft)	–
Screw, pressure regulator	EJOT PT® K60x25-Z	3 Nm (2.2 lbf ft)	–
Spoke nipple	M4.5	6 Nm (4.4 lbf ft)	–
Screw, battery terminal	M5	2.5 Nm (1.84 lbf ft)	–
Screw, intake air temperature sensor	M5	2 Nm (1.5 lbf ft)	–
Screw, shock absorber adjusting ring	M5	5 Nm (3.7 lbf ft)	–
Screws on the main silencer	M5	7 Nm (5.2 lbf ft)	–
Nut, cable on starter motor	M6	4 Nm (3 lbf ft)	–
Remaining nuts, chassis	M6	10 Nm (7.4 lbf ft)	–
Remaining screws, chassis	M6	10 Nm (7.4 lbf ft)	–
Screw for spoiler attachment	M6	5 Nm (3.7 lbf ft)	–
Screw, ball joint of push rod on foot brake cylinder	M6	10 Nm (7.4 lbf ft)	Loctite® 243™
Screw, front brake disc	M6	14 Nm (10.3 lbf ft)	Loctite® 243™
Screw, radiator bracket	M6	7 Nm (5.2 lbf ft)	–
Screw, rear brake disc	M6	14 Nm (10.3 lbf ft)	Loctite® 243™
Screws, throttle grip	M6	3 Nm (2.2 lbf ft)	–
Fuel connection on fuel pump	M8	10 Nm (7.4 lbf ft)	–
Nut, foot brake lever stop	M8	20 Nm (14.8 lbf ft)	–
Nut, rear sprocket screw	M8	35 Nm (25.8 lbf ft)	Loctite® 2701™
Nut, rim lock	M8	10 Nm (7.4 lbf ft)	–
Remaining nuts, chassis	M8	25 Nm (18.4 lbf ft)	–
Remaining screws, chassis	M8	25 Nm (18.4 lbf ft)	–
Screw of rear brake caliper	M8	25 Nm (18.4 lbf ft)	Loctite® 243™
Screw, bottom triple clamp	M8	18 Nm (13.3 lbf ft)	–
Screw, chain sliding piece	M8	15 Nm (11.1 lbf ft)	–
Screw, engine brace on frame	M8	25 Nm (18.4 lbf ft)	Loctite® 243™
Screw, fork stub	M8	15 Nm (11.1 lbf ft)	–
Screw, front brake caliper	M8	25 Nm (18.4 lbf ft)	Loctite® 243™
Screw, fuel tank	M8	15 Nm (11.1 lbf ft)	Loctite® 243™
Screw, handlebar clamp	M8	20 Nm (14.8 lbf ft)	–
Screw, side stand attachment	M8	25 Nm (18.4 lbf ft)	Loctite® 2701™
Screw, subframe	M8	30 Nm (22.1 lbf ft)	Loctite® 243™
Screw, top steering stem	M8	17 Nm (12.5 lbf ft)	Loctite® 243™
Screw, top triple clamp	M8	22 Nm (16.2 lbf ft)	–
Engine bracket screw	M10	60 Nm (44.3 lbf ft)	–
Nut, fuel tank attachment	M10	10 Nm (7.4 lbf ft)	–
Remaining nuts, chassis	M10	45 Nm (33.2 lbf ft)	–
Remaining screws, chassis	M10	45 Nm (33.2 lbf ft)	–
Screw, battery compartment	M10	45 Nm (33.2 lbf ft)	–
Screw, cross bar	M10	45 Nm (33.2 lbf ft)	–
Screw, foot brake lever	M10	30 Nm (22.1 lbf ft)	Loctite® 243™
Screw, footrest bracket	M10	45 Nm (33.2 lbf ft)	Loctite® 243™
Screw, handlebar support	M10	40 Nm (29.5 lbf ft)	Loctite® 243™
Screw, upper subframe	M10	45 Nm (33.2 lbf ft)	Loctite® 243™
Nut, fuel pump fixation	M12	15 Nm (11.1 lbf ft)	–
Screw, bottom shock absorber	M12	80 Nm (59 lbf ft)	Loctite® 2701™
Screw, top shock absorber	M12	80 Nm (59 lbf ft)	Loctite® 2701™
Nut, swingarm pivot	M14x1.5	75 Nm (55.3 lbf ft)	–
Nut, rear wheel spindle	M20x1.5	80 Nm (59 lbf ft)	–

## 5 TECHNICAL DATA

Screw, front wheel spindle	M20x1.5	35 Nm (25.8 lbf ft)	-
Screw, top steering head	M20x1.5	12 Nm (8.9 lbf ft)	-

## Super unleaded (ROZ 95/RON 95/PON 91)

### Standard/classification

- DIN EN 228 (ROZ 95/RON 95/PON 91)

### Guideline

- Only use unleaded super fuel that matches or is equivalent to the specified fuel grade.
- Fuel with an ethanol content of up to 10 % (E10 fuel) is safe to use.



### Info

Do **not** use fuel containing methanol (e. g. M15, M85, M100) or more than 10 % ethanol (e. g. E15, E25, E85, E100).



## Long-life grease

Recommended supplier

Motorex®

– Bike Grease 2000



3213455en

11/2015

