

## 1090 Adventure

Art. no. 3213545en



**KTM**



# DEAR KTM CUSTOMER

Congratulations on your decision to purchase a KTM motorcycle. You are now the owner of a state-of-the-art sports motorcycle that will give you enormous pleasure if you service and maintain it properly.

We hope you enjoy your new vehicle!

Please enter the serial numbers of your vehicle below.

Chassis number (📖 p. 22)	Dealer's stamp
Engine number (📖 p. 24)	
Key number (📖 p. 23)	

The Owner's Manual contained the latest information for this model series at the time of going to print. However, minor differences due to developments in design cannot be ruled out completely.

All specifications are non-binding. KTM Sportmotorcycle GmbH specifically reserves the right to modify or delete technical specifications, prices, colors, forms, materials, services, designs, equipment, etc., without prior notice and without specifying reasons, to adapt these to local conditions, as well as to stop production of a particular model without prior notice. KTM accepts no liability for delivery options, deviations from illustrations and descriptions, misprints, and other errors. The models portrayed partly contain special equipment that does not belong to the regular scope of supply.

© 2016 KTM Sportmotorcycle GmbH, Mattighofen Austria  
All rights reserved



3213545en

10/2016

# DEAR KTM CUSTOMER

Reproduction, even in part, as well as copying of all kinds, is permitted only with the express written permission of the copyright owner.



ISO 9001(12 100 6061)

According to the international quality management standard ISO 9001, KTM uses quality assurance processes that lead to the maximum possible quality of the products.

Issued by: TÜV Management Service

REG.NO. 12 100 6061

KTM Sportmotorcycle GmbH  
5230 Mattighofen, Austria

This document is valid for the following models:

1090 Adventure EU (F9903QC)





1090 Adventure L EU (F9903QB)

1090 Adventure CN (F9987QC)

# TABLE OF CONTENTS

1	MEANS OF REPRESENTATION .....	8	5.5	Fork part number .....	24
1.1	Symbols used .....	8	5.6	Shock absorber article number .....	25
1.2	Formats used.....	9	6	CONTROLS.....	26
2	SAFETY ADVICE.....	10	6.1	Clutch lever.....	26
2.1	Use definition - intended use .....	10	6.2	Hand brake lever.....	26
2.2	Misuse.....	10	6.3	Throttle grip .....	27
2.3	Safety advice.....	10	6.4	Switches on the left side of the handlebar .....	27
2.4	Degrees of risk and symbols .....	11	6.4.1	Combination switch.....	27
2.5	Tampering warning.....	11	6.4.2	Light switch .....	28
2.6	Safe operation .....	12	6.4.3	Hazard warning flasher switch.....	28
2.7	Protective clothing .....	13	6.4.4	Menu switch.....	29
2.8	Work rules.....	13	6.4.5	Turn signal switch.....	29
2.9	Environment.....	13	6.4.6	Horn button .....	30
2.10	Owner's Manual .....	14	6.5	Switches on the right side of the handlebar .....	31
3	IMPORTANT NOTES.....	15	6.5.1	Emergency OFF switch .....	31
3.1	Warranty .....	15	6.5.2	Electric starter button .....	31
3.2	Operating and auxiliary substances .....	15	6.6	Ignition/steering lock .....	32
3.3	Spare parts, accessories .....	15	6.7	Immobilizer .....	32
3.4	Service .....	16	6.8	Locking the steering.....	33
3.5	Figures .....	16	6.9	Unlocking the steering.....	34
3.6	Customer service.....	16	6.10	Opening the filler cap.....	34
4	VIEW OF VEHICLE .....	18	6.11	Closing the filler cap .....	36
4.1	View of vehicle, front left (example) .....	18	6.12	Fuel cocks.....	37
4.2	View of vehicle, rear right side (example).....	20	6.13	Opening the storage compartment .....	38
5	SERIAL NUMBERS .....	22	6.14	Closing the storage compartment.....	38
5.1	Chassis number .....	22	6.15	Seat lock.....	39
5.2	Type label .....	22	6.16	Grab handles .....	39
5.3	Key number.....	23	6.17	Luggage rack plate.....	40
5.4	Engine number .....	24	6.18	Passenger footrest.....	40

# TABLE OF CONTENTS

6.19	Shift lever .....	41	7.10.16	"Fuel Cons" .....	59
6.20	Foot brake lever .....	42	7.10.17	"Clock/Date" .....	60
6.21	Side stand.....	42	7.10.18	"Shift Light" .....	60
7	COMBINATION INSTRUMENT .....	43	7.10.19	"Heat Grip" (optional) .....	61
7.1	Overview .....	43	7.10.20	"DRL" .....	61
7.2	Activation and test .....	43	8	ERGONOMICS .....	63
7.3	Matrix display .....	44	8.1	Handlebar position .....	63
7.4	Segment display .....	44	8.2	Adjusting the handlebar position  .....	63
7.5	Fuel level display .....	45	8.3	Adjusting the wind shield .....	65
7.6	Indicator lamps.....	45	8.4	Adjusting basic position of clutch lever .....	66
7.7	Message on the matrix display.....	46	8.5	Adjusting the basic position of the hand brake lever .....	67
7.8	Shift warning light .....	47	8.6	Rider footrests.....	67
7.9	service display .....	48	8.7	Adjusting the footrests  .....	68
7.10	Matrix display menu .....	49	8.8	Checking the basic position of the shift lever .....	70
7.10.1	"Favorites".....	49	8.9	Adjusting the basic position of the shift lever  .....	71
7.10.2	"Trip 1" .....	49	8.10	Adjusting the basic position of the foot brake lever  .....	72
7.10.3	"Trip 2" .....	50	9	PREPARING FOR USE.....	74
7.10.4	"General Info".....	50	9.1	Advice on first use .....	74
7.10.5	"Set Favorites" .....	51	9.2	Running in the engine .....	75
7.10.6	"Settings" .....	51	9.3	Loading the vehicle .....	76
7.10.7	"Warning" .....	52	10	RIDING INSTRUCTIONS.....	78
7.10.8	"Heating" (optional).....	52	10.1	Checks and maintenance measures when preparing for use.....	78
7.10.9	"MTC/ABS".....	53	10.2	Starting.....	79
7.10.10	"Drive Mod" .....	53	10.3	Starting off.....	80
7.10.11	Menu overview.....	56	10.4	Shifting, riding .....	80
7.10.12	"Language".....	57	10.5	Applying the brakes.....	84
7.10.13	"Distance" .....	58	10.6	Stopping, parking.....	86
7.10.14	"Temp" .....	58			
7.10.15	"Pressure" .....	59			

# TABLE OF CONTENTS

10.7	Transport .....	88	13.14	Checking/correcting the fluid level of the hydraulic clutch.....	109
10.8	Refueling .....	89	13.15	Checking the play of the steering head bearing ...	110
11	SERVICE SCHEDULE .....	91	13.16	Removing the bottom triple clamp cover.....	111
11.1	Additional information.....	91	13.17	Installing the bottom triple clamp cover .....	112
11.2	Required work .....	91	13.18	Removing the front side cover .....	113
11.3	Recommended work .....	93	13.19	Installing the front side cover .....	114
12	SUSPENSION SETTING.....	94	13.20	Removing the mask spoiler 🛠.....	116
12.1	Adjusting the rebound damping of the shock absorber.....	94	13.21	Installing the mask spoiler 🛠 .....	118
12.2	Adjusting the spring preload of the shock absorber.....	94	13.22	Removing the front fender .....	121
13	SERVICE WORK ON THE CHASSIS.....	96	13.23	Installing the front fender .....	121
13.1	Raising the motorcycle with the rear lifting gear....	96	13.24	Cleaning the dust boots of the fork legs 🛠.....	122
13.2	Removing the rear of motorcycle from the lifting gear.....	96	13.25	Removing the tank cover.....	123
13.3	Lifting the motorcycle with the front lifting gear....	97	13.26	Installing the tank cover .....	125
13.4	Taking the motorcycle from the front lifting gear...	98	13.27	Removing the wind shield .....	127
13.5	Raising the motorcycle with the work stand (inserted) 🛠.....	99	13.28	Installing the wind shield.....	127
13.6	Removing the motorcycle from the work stand (inserted) 🛠.....	100	13.29	Removing the engine guard.....	128
13.7	Removing the seat .....	101	13.30	Installing the engine guard .....	128
13.8	Mounting the seat .....	101	14	BRAKE SYSTEM .....	129
13.9	Checking for chain dirt .....	102	14.1	ABS / anti-blocking system .....	129
13.10	Cleaning the chain .....	102	14.2	Checking the brake discs .....	131
13.11	Checking the chain tension .....	103	14.3	Checking the brake fluid level of the front brake.....	132
13.12	Adjusting the chain tension.....	104	14.4	Adding front brake fluid 🛠.....	133
13.13	Checking the chain, rear sprocket, and engine sprocket.....	106	14.5	Checking the front brake linings .....	134
			14.6	Checking the rear brake fluid level.....	135
			14.7	Adding rear brake fluid 🛠.....	136
			14.8	Checking the rear brake linings .....	138

# TABLE OF CONTENTS

15	WHEELS, TIRES .....	140	18	TUNING THE ENGINE.....	185
15.1	Removing the front wheel 🛠.....	140	18.1	"Drive Mod" .....	185
15.2	Installing the front wheel 🛠.....	142	18.2	Traction control (TC) .....	185
15.3	Removing the rear wheel 🛠.....	145	19	SERVICE WORK ON THE ENGINE .....	187
15.4	Installing the rear wheel 🛠.....	147	19.1	Checking the engine oil level.....	187
15.5	Checking the rear hub rubber dampers 🛠.....	149	19.2	Changing the engine oil and oil filter, cleaning the oil screens 🛠 .....	188
15.6	Checking the tire condition .....	151	19.3	Adding engine oil .....	192
15.7	Checking the tire air pressure.....	152	20	CLEANING, CARE .....	195
16	ELECTRICAL SYSTEM .....	154	20.1	Cleaning motorcycle .....	195
16.1	Daytime running light.....	154	20.2	Checks and maintenance steps for winter operation.....	197
16.2	Removing the battery 🛠.....	155	21	STORAGE .....	199
16.3	Installing the battery 🛠.....	157	21.1	Storage .....	199
16.4	Recharging the battery 🛠.....	159	21.2	Preparing for use after storage.....	200
16.5	Changing the main fuse.....	163	22	TROUBLESHOOTING .....	201
16.6	Changing the fuses in the fuse box .....	165	23	TECHNICAL DATA .....	203
16.7	Removing the headlight mask with the headlight.....	167	23.1	Engine .....	203
16.8	Installing the headlight mask with the headlight.....	169	23.2	Engine tightening torques .....	204
16.9	Changing the low beam bulb .....	170	23.3	Capacities .....	208
16.10	Changing the high beam bulb.....	171	23.3.1	Engine oil .....	208
16.11	Changing the turn signal bulb .....	173	23.3.2	Coolant .....	208
16.12	Checking the headlight setting .....	174	23.3.3	Fuel .....	208
16.13	Adjusting the headlight range.....	175	23.4	Chassis .....	208
16.14	Activating/deactivating the ignition key .....	176	23.5	Electrical system.....	210
17	COOLING SYSTEM .....	181	23.6	Tires .....	211
17.1	Checking the coolant level in the compensating tank.....	181	23.7	Fork.....	211
17.2	Correcting the coolant level in the compensating tank.....	182	23.8	Shock absorber .....	211
			23.9	Chassis tightening torques .....	212



# TABLE OF CONTENTS

24	SUBSTANCES .....	216
25	AUXILIARY SUBSTANCES .....	219
26	STANDARDS .....	221
27	INDEX OF SPECIAL TERMS .....	222
28	LIST OF ABBREVIATIONS.....	223
29	LIST OF SYMBOLS.....	224
29.1	Red symbols.....	224
29.2	Yellow and orange symbols.....	224
29.3	Green and blue symbols.....	224
	INDEX .....	226

## 1.1 Symbols used

The meaning of specific symbols is described below.

---



Indicates an expected reaction (e.g. of a work step or a function).



Indicates an unexpected reaction (e.g. of a work step or a function).



All work marked with this symbol requires specialist knowledge and technical understanding. In the interest of your own safety, have these jobs performed by an authorized KTM workshop. There, your motorcycle will be optimally cared for by specially trained experts using the specialist tools required.



Indicates a page reference (more information is provided on the specified page).



Indicates information with more details or tips.



Indicates the result of a testing step.

---

# 1 MEANS OF REPRESENTATION

## 1.2 Formats used

The typographical formats used in this document are explained below.

---

<b>Specific name</b>	Identifies a proprietary name.
<b>Name®</b>	Identifies a protected name.
<b>Brand™</b>	Identifies a brand available on the open market.
<b><u>Underlined terms</u></b>	Refer to technical details of the vehicle or indicate technical terms that are explained in the glossary.

---

### 2.1 Use definition - intended use

KTM sport motorcycles are designed and constructed to meet the normal demands of regular road and light offroad operation (dirt roads), but not for use on race courses.

---



#### Info

The motorcycle is only authorized for operation on public roads in the homologated version.

---

### 2.2 Misuse

The vehicle must only be used as intended.

Dangers can arise for people, property and the environment through use not as intended.

Any use of the vehicle beyond the intended and defined use constitutes misuse.

Misuse also includes the use of operating and auxiliary fluids which do not meet the required specification for the respective use.

### 2.3 Safety advice

A number of safety instructions need to be followed to operate the vehicle safely. Therefore, read this manual carefully. The safety instructions are highlighted in the text and are referred to at the relevant passages.

---



#### Info

The vehicle has various information and warning labels at prominent locations. Do not remove information/warning labels. If they are missing, you or others may not recognize dangers and may therefore be injured.

---

### 2.4 Degrees of risk and symbols

---



#### **Danger**

Indicates a danger that will immediately and invariably lead to fatal or serious permanent injury if the appropriate measures are not taken.



#### **Warning**

Indicates a danger that is likely to lead to fatal or serious injury if the appropriate measures are not taken.



#### **Caution**

Indicates a danger that may lead to minor injuries if the appropriate measures are not taken.

#### **Note**

Indicates a danger that will lead to considerable machine and material damage if the appropriate measures are not taken.



#### **Warning**

Indicates a danger that will lead to environmental damage if the appropriate measures are not taken.

---

### 2.5 Tampering warning

Tampering with the noise control system is prohibited. Federal law prohibits the following acts or the causing thereof:

- 1 The removal or rendering inoperative by any person other than for purposes of maintenance, repair, or replacement, of any device or element of design incorporated into any new vehicle for the purpose of noise control prior to its sale or delivery to the ultimate purchaser or while it is in use, or
- 2 the use of the vehicle after such device or element of design has been removed or rendered inoperative by any person.

Among those acts presumed to constitute tampering are the acts listed below:

- 1 Removal or puncturing of the main silencer, baffles, header pipes or any other components which conduct exhaust gases.
- 2 Removal or puncturing of parts of the intake system.
- 3 Lack of proper maintenance.
- 4 Replacing moving part of the vehicle, or parts of the exhaust or intake system, with parts other than those specified by the manufacturer.

### 2.6 Safe operation



#### **Danger**

**Danger of accidents** A rider who is not fit to ride poses a danger to him or herself and others.

- Do not operate the vehicle if you are not fit to ride due to alcohol, drugs or medication.
- Do not operate the vehicle if you are physically or mentally impaired.



#### **Danger**

**Danger of poisoning** Exhaust gases are toxic and inhaling them may result in unconsciousness and death.

- Always make sure there is sufficient ventilation when running the engine.
- Use an effective exhaust extraction system when starting or running the engine in an enclosed space.



#### **Warning**

**Danger of burns** Some vehicle components become very hot when the vehicle is operated.

- Do not touch any parts such as the exhaust system, radiator, engine, shock absorber, or brake system before the vehicle parts have cooled down.
- Let the vehicle parts cool down before you perform any work on the vehicle.

Only operate the vehicle when it is in perfect technical condition, in accordance with its intended use, and in a safe and environmentally compatible manner.

The vehicle should only be used by trained persons. An appropriate driver's license is needed to ride the vehicle on public roads.

Have malfunctions that impair safety promptly eliminated by an authorized KTM workshop.

Adhere to the information and warning labels on the vehicle.

### 2.7 Protective clothing



#### Warning

**Risk of injury** Missing or poor protective clothing presents an increased safety risk.

- Wear appropriate protective clothing such as helmet, boots, gloves as well as trousers and a jacket with protectors on all rides.
- Always wear protective clothing that is in good condition and meets the legal regulations.

In the interest of your own safety, KTM recommends that you only operate the vehicle while wearing protective clothing.

### 2.8 Work rules

Special tools are necessary for some of the work. These are not included with the vehicle and can be ordered under the number in parentheses. Ex: valve spring mounter (59029019000)

During assembly, non-reusable parts (e.g. self-locking screws and nuts, seals and seal rings, O-rings, pins, lock washers) must be replaced by new parts.

Where thread lockers are used on screw connections (e.g., **Loctite**®), follow the instructions for use from the manufacturer.

Parts that you want to reuse following repairs and servicing should be cleaned and checked for damage and wear. Change damaged or worn parts.

Following repairs or servicing, the vehicle must be checked for roadworthiness.

### 2.9 Environment

If you use your motorcycle responsibly, you can ensure that problems and conflicts do not occur. To protect the future of the motorcycle sport, make sure that you use your motorcycle legally, display environmental consciousness, and respect the rights of others.

When disposing of used oil, other operating and auxiliary fluids, and used components, comply with the laws and regulations of the respective country.

Because motorcycles are not subject to the EU regulations governing the disposal of used vehicles, there are no legal regulations that pertain to the disposal of an end-of-life motorcycle. Your authorized KTM dealer will be glad to advise you.

### 2.10 Owner's Manual

It is important that you read this Owner's Manual carefully and completely before making your first trip. The Owner's Manual contains useful information and many tips on how to operate, handle, and maintain your motorcycle. Only then will you find out how to customize the vehicle ideally for your own use and how you can protect yourself from injury.

Keep the Owner's Manual in an accessible place to enable you to refer to it as needed.

If you would like to know more about the vehicle or have questions on the material you read, please contact an authorized KTM dealer.

The Owner's Manual is an important component of the vehicle and should be handed over to the new owner if the vehicle is sold.



### 3.1 Warranty

The work specified in the service schedule may only be performed in an authorized KTM workshop and must be recorded in both the Service & Warranty Booklet and in **KTM Dealer.net**, otherwise any warranty coverage will become void. No warranty claims can be considered for damage resulting from manipulations and/or alterations to the vehicle. Additional information on the manufacturer or implied warranty and the procedures involved can be found in the service & warranty booklet.

### 3.2 Operating and auxiliary substances



#### Warning

**Environmental hazard** Improper handling of fuel is a danger to the environment.

- Do not allow fuel to enter the groundwater, the soil, or the sewage system.

Use operating and auxiliary substances (such as fuel and lubricants) as specified in the Owner's Manual.

### 3.3 Spare parts, accessories

For your own safety, only use spare parts and accessory products that are approved and/or recommended by KTM and have them installed by an authorized KTM workshop. KTM accepts no liability for other products and any resulting damage or loss. Certain spare parts and accessory products are specified in parentheses in the descriptions. Your authorized KTM dealer will be glad to advise you.

The current **KTM PowerParts** for your vehicle can be found on the KTM website.  
International KTM Website: <http://www.ktm.com>

### 3.4 Service

A prerequisite for perfect operation and prevention of premature wear is that the service, care and tuning work on the engine and chassis are properly carried out as described in the owner's manual. Poor adjustment and tuning of the engine and suspension can lead to damage and breakage of components.

Using the motorcycle in extreme operating conditions, e.g. on very muddy and wet roads or in a dusty and dry environment, can lead to above-average wear of components, such as the drive train, brakes or air filter. For this reasons, it may be necessary to service or replace worn parts before the interval listed in the service schedule is reached.

It is imperative that you adhere to the stipulated run-in times and service intervals. If you observe these exactly, you will ensure a much longer service life for your motorcycle.

### 3.5 Figures

The figures contained in the manual may depict special equipment.

In the interest of clarity, some components may be shown disassembled or may not be shown at all. It is not always necessary to disassemble the component to perform the activity in question. Please follow the instructions in the text.

### 3.6 Customer service

Your authorized KTM dealer will be happy to answer any questions you may have on your vehicle and KTM.

A list of authorized KTM dealers can be found on the KTM website.

International KTM Website: <http://www.ktm.com>



# 4 VIEW OF VEHICLE

## 4.1 View of vehicle, front left (example)

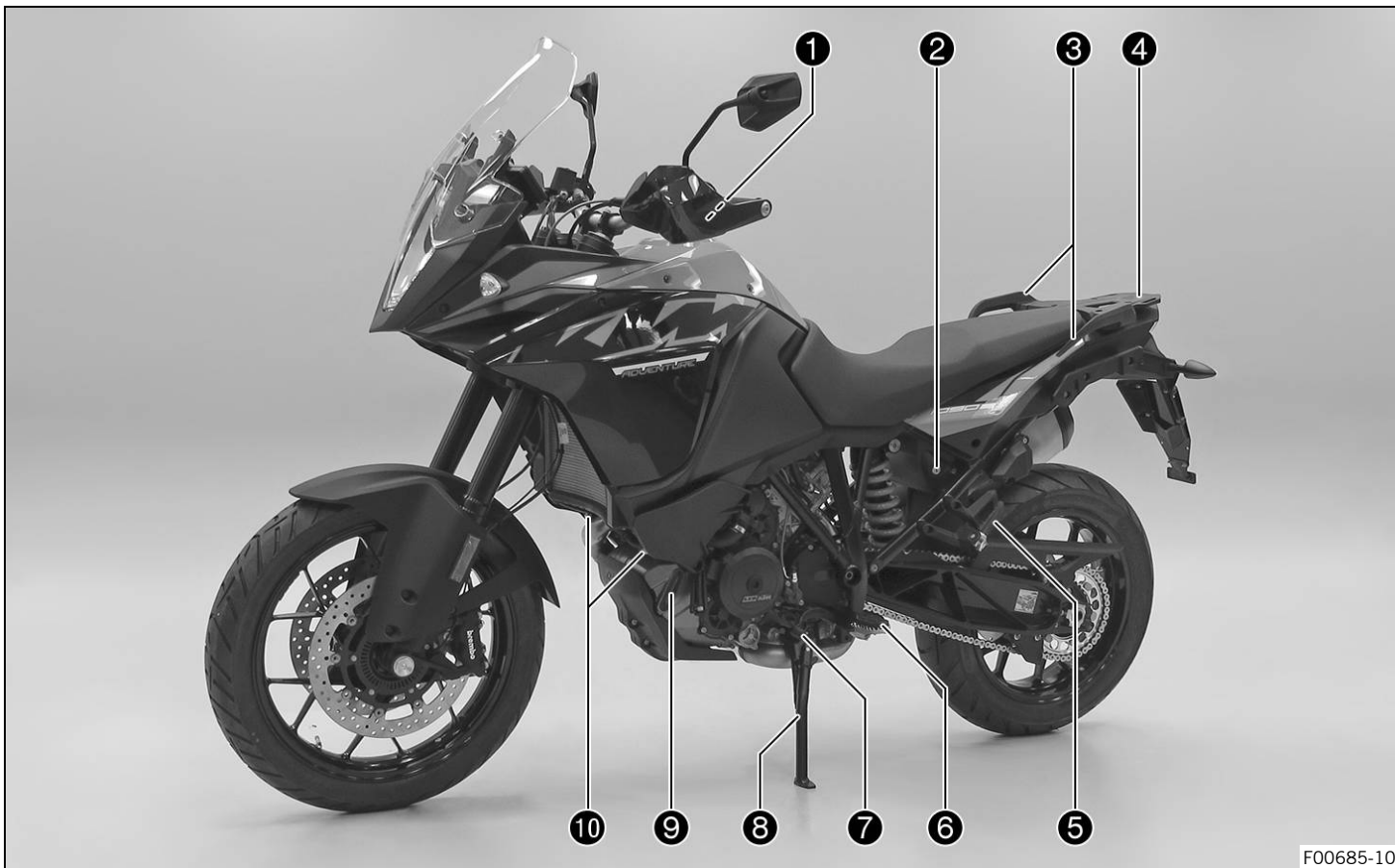

# 4 VIEW OF VEHICLE

1	Clutch lever (📖 p. 26)
2	Seat lock (📖 p. 39)
3	Grab handles (📖 p. 39)
4	Luggage rack plate (📖 p. 40)
5	Passenger footrest (📖 p. 40)
6	Rider footrests (📖 p. 67)
7	Shift lever (📖 p. 41)
8	Side stand (📖 p. 42)
9	Engine oil level viewer
10	Fuel cocks (📖 p. 37)

# 4 VIEW OF VEHICLE

## 4.2 View of vehicle, rear right side (example)

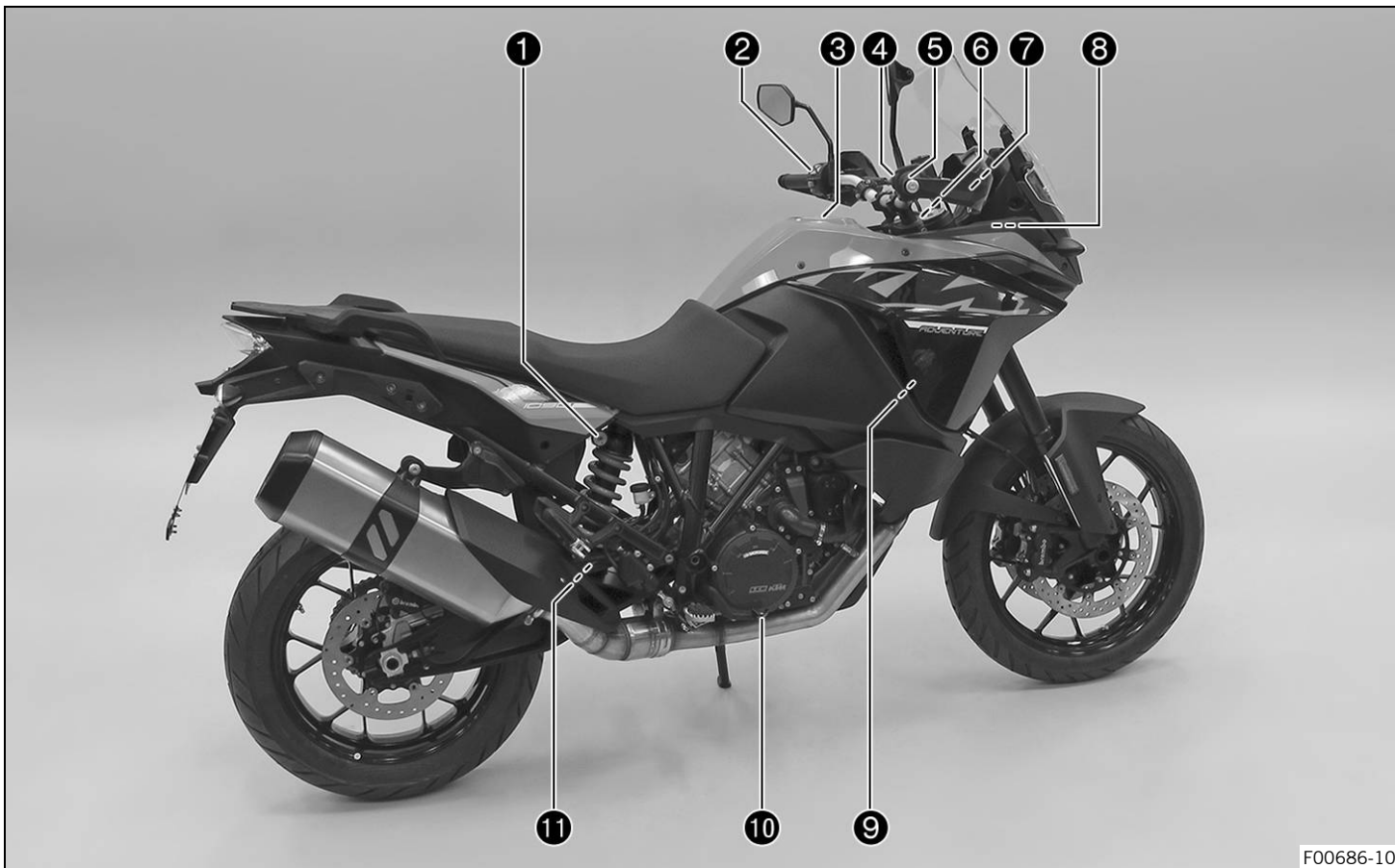

# 4 VIEW OF VEHICLE

1	Shock absorber, spring preload setting
2	Combination switch (📖 p. 27)
3	Filler cap
4	Electric starter button (📖 p. 31)
4	Emergency OFF switch (📖 p. 31)
5	Throttle grip (📖 p. 27)
6	Ignition/steering lock (📖 p. 32)
7	Hand brake lever (📖 p. 26)
8	Storage compartment
9	Cooling system compensating tank
10	Foot brake lever (📖 p. 42)
11	Shock absorber, rebound setting

## 5.1 Chassis number

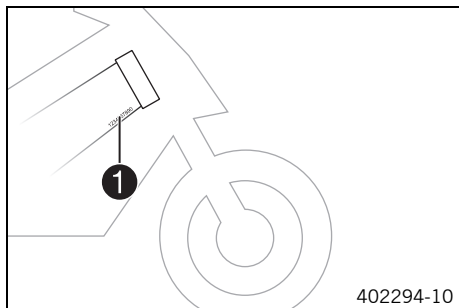

The chassis number ❶ is stamped on the bottom right of the frame behind the steering head.

The chassis number is also shown on the type label.

## 5.2 Type label

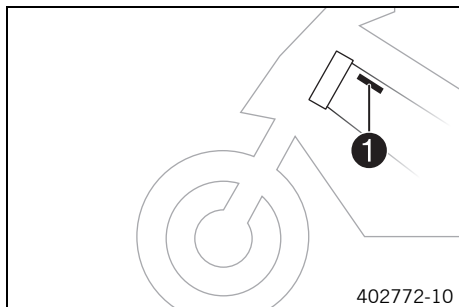

(EU)

Type label ❶ is affixed to the top left of the frame behind the steering head.



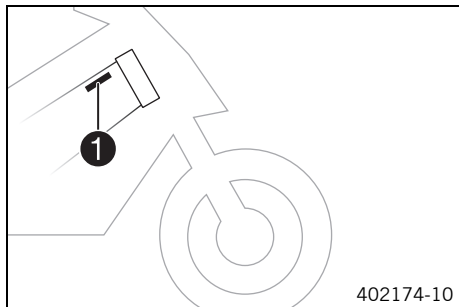

(CN)

Type label ❶ is affixed the top right of the frame behind the steering head.

## 5.3 Key number

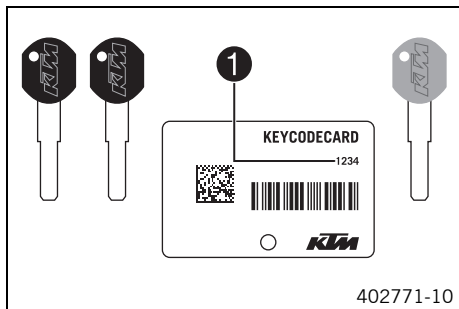

The key number **Code number ❶** can be found on the **KEYCODECARD**.



### Info

You need the key number to order a spare key. Keep the **KEYCODECARD** in a safe place.

Use the orange programming key to activate and deactivate the black ignition key. Keep the orange programming key in a safe place: it must only be used for learning and programming functions.

## 5.4 Engine number

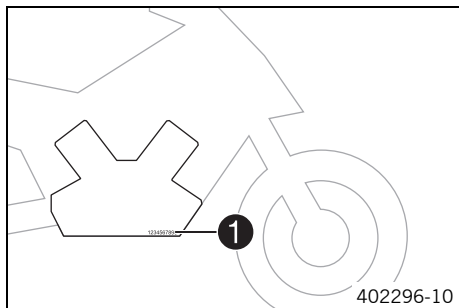

The engine number ❶ is stamped on the right side of the engine.

## 5.5 Fork part number

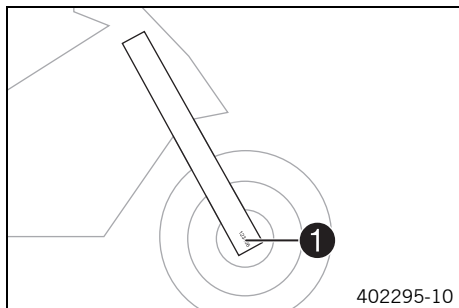

The fork part number ❶ is stamped on the inner side of the fork stub.

## 5.6 Shock absorber article number

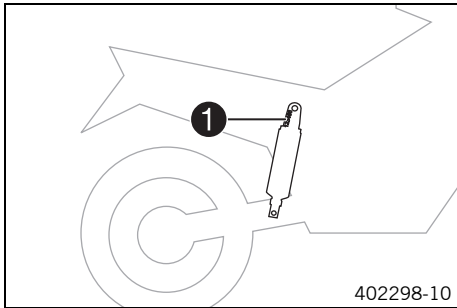

The shock absorber article number ❶ is stamped on the top of the shock absorber.

## 6.1 Clutch lever

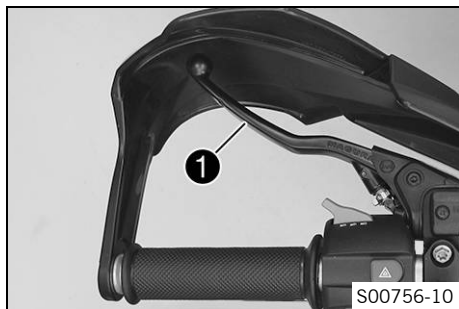

The clutch lever ❶ is fitted on the left side of the handlebar. The clutch is hydraulically operated and self-adjusting.

## 6.2 Hand brake lever

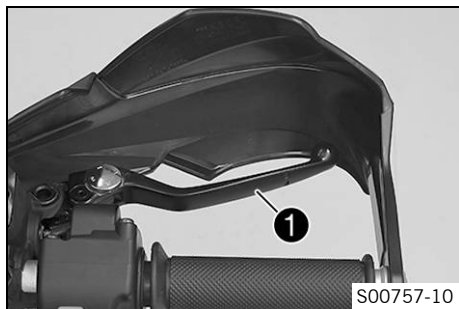

The hand brake lever ❶ is fitted on the right side of the handlebar. The front brake is engaged using the hand brake lever.

## 6.3 Throttle grip

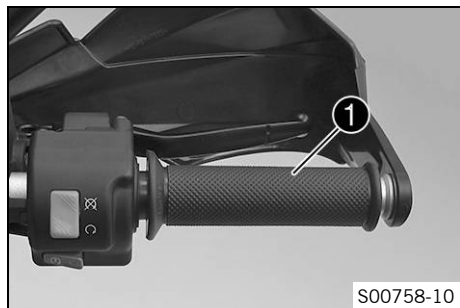

The throttle grip **1** is fitted on the right side of the handlebar.

## 6.4 Switches on the left side of the handlebar

### 6.4.1 Combination switch

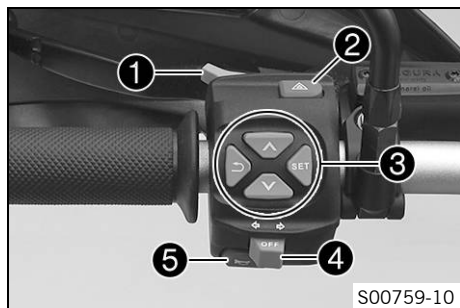

The combination switch is fitted on the left side of the handlebar.

#### Overview of the left combination switch

- |   |   |
|---|---|
| 1 | Light switch (📖 p. 28)                  |
| 2 | Hazard warning flasher switch (📖 p. 28) |
| 3 | Menu switch (📖 p. 29)                   |
| 4 | Turn signal switch (📖 p. 29)            |
| 5 | Horn button (📖 p. 30)                   |

## 6.4.2 Light switch

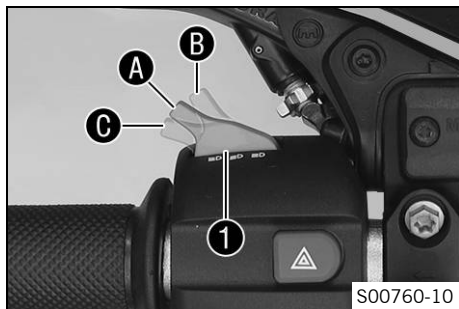

The light switch **1** is fitted on the combination switch on the left.

### Possible states

	Low beam on – Light switch in position <b>A</b> . In this position, the low beam and tail light are switched on.
	High beam on – Push the light switch to position <b>B</b> . In this position, the high beam and the tail light are switched on.
	Headlight flasher. – Push the light switch into position <b>C</b> .

## 6.4.3 Hazard warning flasher switch



The hazard warning flasher switch **1** is fitted on the combination switch on the left. The hazard warning flasher is used to indicate emergency situations.

### Info

The hazard warning flasher can be activated or deactivated while the ignition is switched on or up to 60 seconds after the ignition is switched off. Only keep the hazard warning flasher activated as long as necessary as it depletes the battery.

### Possible states

	Hazard warning flasher on – All four turn signals and the green turn signal indicator lights in the combination instrument flash.
--	---

## 6.4.4 Menu switch

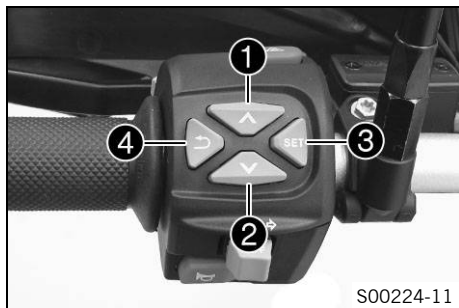

The menu switch is fitted in the middle of the left combination switch. The menu buttons are used to control the matrix display on the combination instrument.

Button **1** is the **UP** button.  
 Button **2** is the **DOWN** button.  
 Button **3** is the **SET** button.  
 Button **4** is the **BACK** button.

## 6.4.5 Turn signal switch



The turn signal switch **1** is fitted on the combination switch on the left.

### Possible states

<b>OFF</b>	Turn signal off – Push the turn signal switch toward the switch housing.
	Left turn signal, on – Turn signal switch pressed to the left. The turn signal switch returns automatically to the central position after use.
	Right turn signal, on – Turn signal switch pressed to the right. The turn signal switch returns automatically to the central position after use.

To switch off the turn signal, press the turn signal switch towards the switch case.



### Info

An automatic turn signal switch-off function (**ATIR**) is available as an optional software feature.

The **ATIR** function uses a time and distance counter.

If the turn signal has been on for at least 10 seconds and 150 meters of riding distance, the turn signal is switched off.

If the vehicle is stationary, both counters are stopped.



If the turn signal switch is reactivated, both counters are reset.

## 6.4.6 Horn button



The horn button ① is fitted on the combination switch on the left.

### Possible states

- Horn button  in basic position.
- Horn button  pressed – The horn is operated in this position.





## 6.5 Switches on the right side of the handlebar

### 6.5.1 Emergency OFF switch



The emergency OFF switch ❶ is fitted on the right side of the handlebar.

#### Possible states

	Emergency OFF switch off – In this position, the ignition circuit is interrupted, a running engine stops, and a non-running engine cannot be started. A message appears on the matrix display.
	Emergency OFF switch on – This position is required for operation; the ignition circuit is closed.

### 6.5.2 Electric starter button



The electric starter button ❶ is fitted on the right side of the handlebar.

#### Possible states

- Electric starter button ❸ in basic position.
- Electric starter button ❸ is pressed – In this position, the electric starter is actuated.

## 6.6 Ignition/steering lock

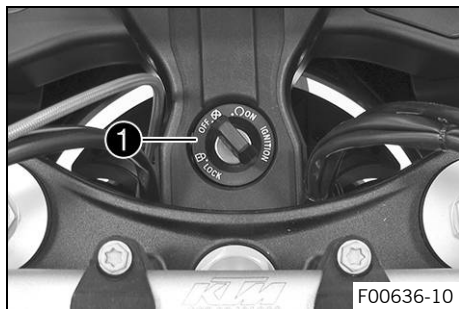

The ignition/steering lock ❶ is located in front of the upper triple clamp.



### Info

The ignition may only be switched on using a black ignition key. With the orange programming key, you can activate or deactivate the black ignition key.

### Possible states

	<p>Ignition off <b>OFF</b> – In this position, the ignition circuit is interrupted, a running engine stops, and a non-running engine will not start. The black ignition key can be removed.</p>
	<p>Ignition on <b>ON</b> – In this position, the ignition circuit is closed and the engine can be started.</p>
	<p>Steering locked – In this position, the ignition circuit is interrupted and the steering locked. The black ignition key can be removed.</p>

## 6.7 Immobilizer

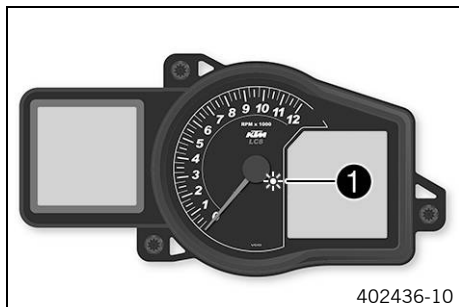

The electronic immobilizer secures the vehicle against unauthorized use.

The immobilizer is activated automatically and the engine electronics are locked when the ignition key is withdrawn.

Immobilizer indicator lamp ❶ can indicate errors by flashing.

If the optional alarm system is installed, immobilizer indicator lamp ❶ flashes when the alarm system is switched on.



### Info

The ignition key contains electronic components. Never attach multiple ignition keys to a single key ring; this may cause mutual interference.

A lost black ignition key must be deactivated to prevent unauthorized persons from operating the vehicle.

The black ignition keys are activated when delivered.

Another two spare ignition keys (key number on the **KEYCODECARD**) can be ordered from an authorized KTM workshop; they need to be activated for use.

## 6.8 Locking the steering

### Note

**Danger of damage** The parked vehicle can roll away or fall over.

- Park the vehicle on a firm and level surface.

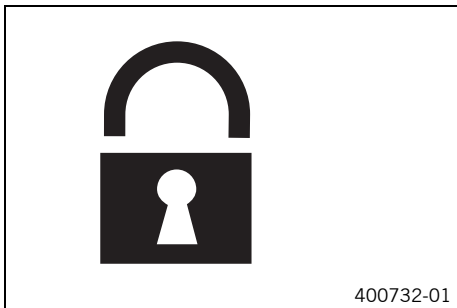

- Park the vehicle.
- Turn the handlebar all the way to the left.
- Insert the key into the ignition/handlebar lock, press in, and turn to the left. Remove the key.
- ✓ Steering is no longer possible.

## 6.9 Unlocking the steering

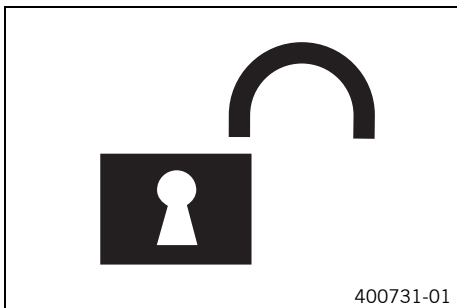

- Insert the key into the ignition/handlebar lock, press in, and turn to the right. Remove the key.
- ✓ You can now steer the bike again.

## 6.10 Opening the filler cap



### **Danger**

**Fire hazard** Fuel is highly flammable.

The fuel in the fuel tank expands when warm and can escape if overfilled.

- Do not refuel the vehicle in the vicinity of open flames or lit cigarettes.
- Switch off the engine for refueling.
- Make sure that no fuel is spilled; particularly not on hot parts of the vehicle.
- If any fuel is spilled, wipe it off immediately.
- Observe the specifications for refueling.



## Warning

**Danger of poisoning** Fuel is poisonous and a health hazard.

- Avoid skin, eye and clothing contact with fuel.
- Immediately consult a doctor if you swallow fuel.
- Do not inhale fuel vapors.
- In case of skin contact, rinse the affected area with plenty of water.
- Rinse the eyes thoroughly with water, and consult a doctor in case of fuel contact with the eyes.
- Change your clothing in case of fuel spills on them.
- Keep fuels correctly in a suitable canister, and out of the reach of children.



## Warning

**Environmental hazard** Improper handling of fuel is a danger to the environment.

- Do not allow fuel to enter the groundwater, the soil, or the sewage system.

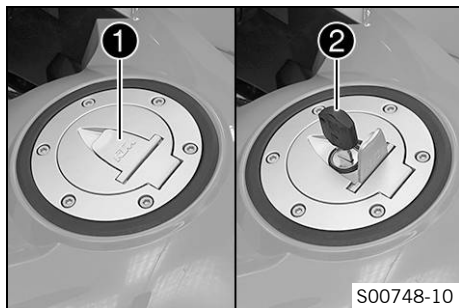

- Lift cover **1** of the filler cap and insert ignition key **2** in the fuel tank lock.

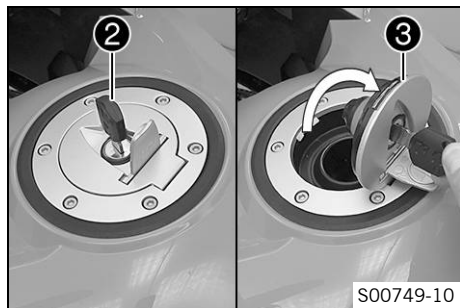

## Note

**Danger of damage** The ignition key may break if overloaded.

Damaged ignition keys must be replaced.

- Push down on the filler cap to take pressure off the ignition key.

- Turn ignition key ② clockwise.
- Fold open filler cap ③.

## 6.11 Closing the filler cap

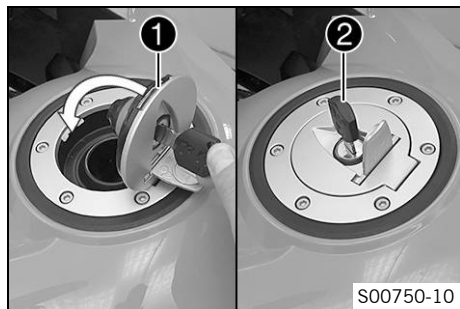

- Fold down filler cap ①.
- Turn ignition key ② clockwise.

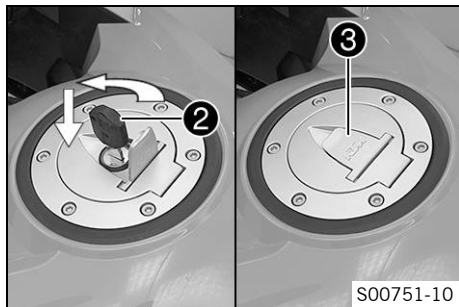

- Push down the filler cap and turn the ignition key **2** counterclockwise until the tank lock closes.



### Warning

**Fire hazard** Fuel is highly flammable, toxic and a health hazard.

- Check the filler cap is locked correctly after closing.
  - Change your clothing in case of fuel spills on them.
  - Rinse the affected area immediately with plenty of water in the event of contact with the skin.
- 
- Remove ignition key **2** and close cover **3**.

## 6.12 Fuel cocks

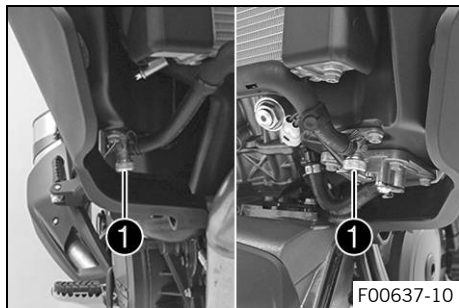

A fuel cock **1** is located on each side of the fuel tank.



### Info

The fuel cocks must always be open during operation.  
The fuel cocks are only closed to remove the fuel tank.

### Possible states

- Fuel cocks are closed – Level equalization cannot take place and the fuel supply to the throttle valve body is shut off.
- Fuel cocks are open – Level equalization can take place and the fuel supply to the throttle valve body is open.

## 6.13 Opening the storage compartment

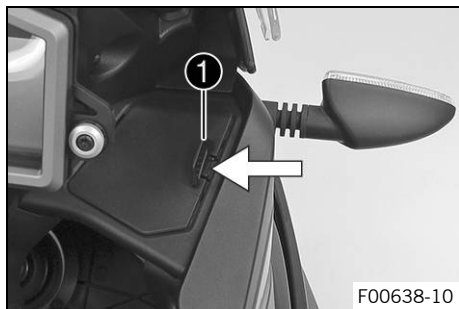

- Press lock **1** in the direction of the arrow and lift the cover at the same time.

## 6.14 Closing the storage compartment

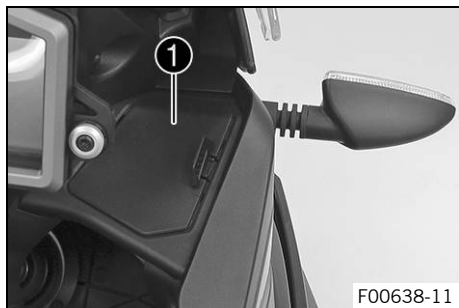

- Press cover **1** downward.
- ✓ The lock engages audibly.



## 6.15 Seat lock

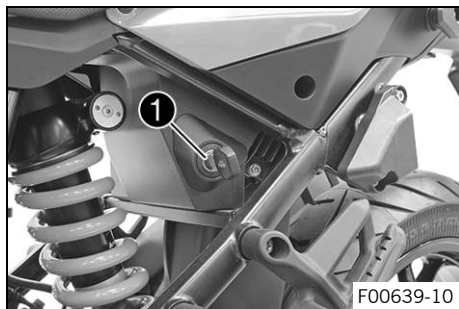

Seat lock **1** is located on the left side of the vehicle. It can be unlocked using the ignition key.

## 6.16 Grab handles

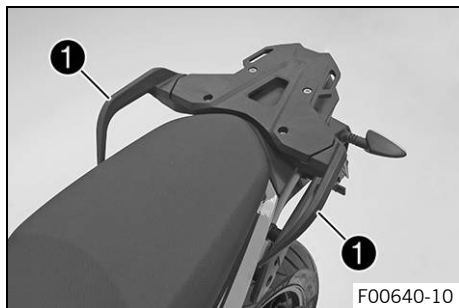

The passenger can hold onto grab handles **1** during the trip.

## 6.17 Luggage rack plate

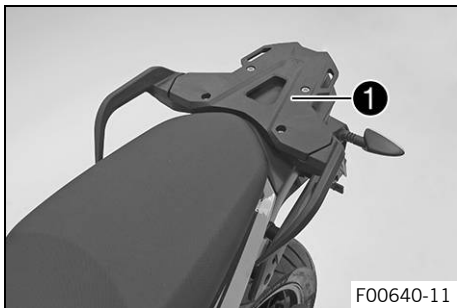

The luggage rack plate ❶ is located behind the seat.

The base plate of a luggage system (optional) can be attached to the luggage rack plate. The luggage rack plate may not be loaded with more than the specified weight.

Maximum permissible load on luggage rack plate	8 kg (18 lb.)
--	---------------



### Info

Note the information provided by the luggage manufacturer.

## 6.18 Passenger footrest

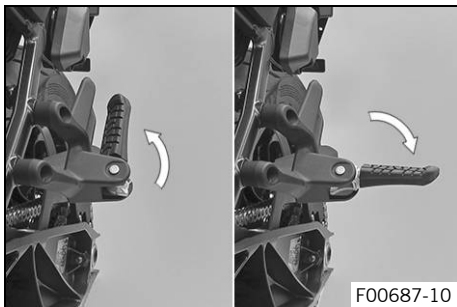

The passenger footrests are foldable.

### Possible states

- Passenger footrest folded in – For operation without a passenger.
- Passenger footrest folded out – For operation with a passenger.

## 6.19 Shift lever

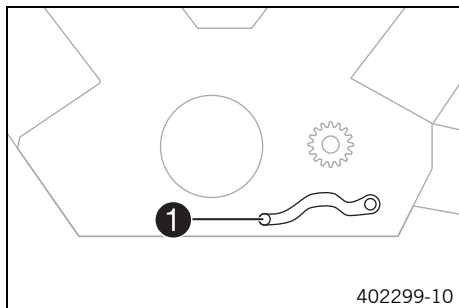

The shift lever **1** is fitted on the left side of the engine.

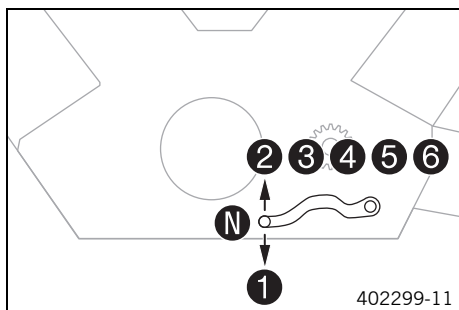

The gear positions can be seen in the figure.  
The idle position is between the first and second gears.

## 6.20 Foot brake lever

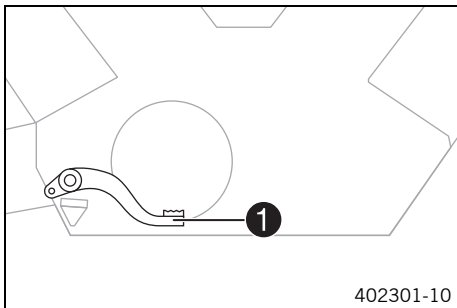

Foot brake lever **1** is located in front of the right footrest. The rear brake is activated using the foot brake lever.

## 6.21 Side stand

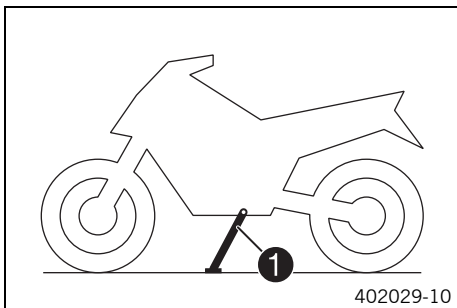

The side stand **1** is located on the left side of the vehicle. The side stand is used for parking the motorcycle.



### Info

The side stand must be folded up during motorcycle use. The side stand is coupled with the safety starting system. See the instructions in the "Stopping, parking" chapter.

### Possible states

- Side stand folded out – The vehicle can be supported on the side stand. The safety starting system is active.
- Side stand folded in – This position is mandatory when riding the motorcycle. The safety starting system is inactive.

## 7.1 Overview

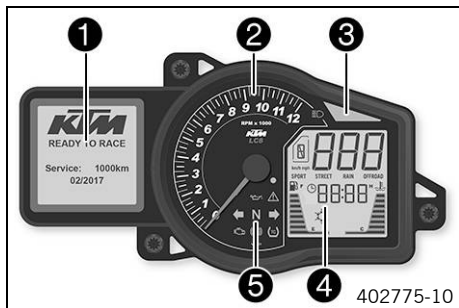

- 1 Matrix display (📖 p. 44)
- 2 Tachometer
- 3 Shift warning light (📖 p. 47)
- 4 Segment display
- 5 Indicator lamps (📖 p. 45)

## 7.2 Activation and test



### Activation

The combination instrument is activated when the ignition is switched on.

### Info

The brightness of the displays is controlled by a brightness sensor in the combination instrument.

### Test

The segment display, the indicator lamps, and the tachometer are briefly activated for a function test.

The welcome text and information on the next service (📖 p. 48) appear on the matrix display.

### Info

If the battery was disconnected, the time and date must be set.

## 7.3 Matrix display

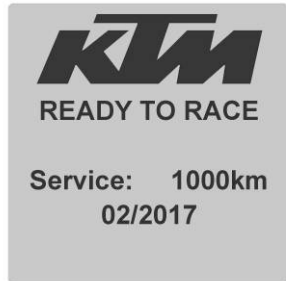

F00706-01

The matrix display is controlled using the menu switch (📖 p. 29). After the ignition is switched on, the display shows when the next service (📖 p. 48) is due. If the General warning lamp 🚨 lights up among the indicator lamps (📖 p. 45), the corresponding message appears in the matrix display. The **SET** button is used to confirm receipt of the information and the message is cleared.

Messages appear	10 s
-----------------	------

## 7.4 Segment display



M00865-10

1	Fuel level display (📖 p. 45)
2	Time symbol
3	Unit for the speedometer
4	Gear display
5	Speed
6	"Drive Mod" (📖 p. 185)
7	Time
8	Coolant temperature
9	Ice warning

## 7.5 Fuel level display

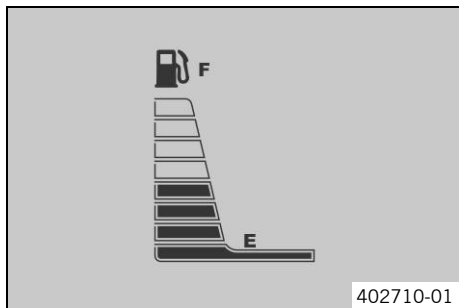

The fuel level display shows the filling level of the fuel tank.



### Info

The fuel level is displayed with a slight delay to prevent the indicator from constantly moving while riding.

The fuel level display is not updated while the side stand is folded out or the emergency off switch is switched off.

Once the side stand is folded up and emergency OFF switch is switched on, the fuel level display is next updated after 2 minutes.





The fuel level display flashes if the combination instrument does not receive a signal from the fuel level sensor.

## 7.6 Indicator lamps



### Possible states





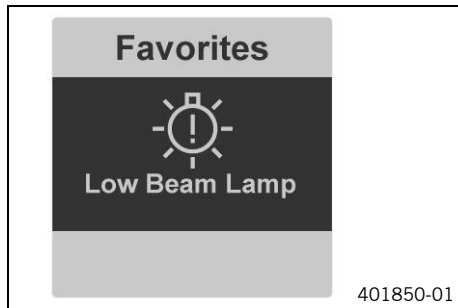

	The high beam indicator lamp lights up blue – The high beam is switched on.
	The immobilizer indicator lamp lights up or flashes red – Status or error message for immobilizer/alarm system.
	The oil pressure warning lamp lights up red – Engine oil pressure is too low.
	The general warning lamp lights up yellow – An operating safety (warning) message was detected. This is also shown on the matrix display.
	The left turn signal lamp flashes green with a steady rhythmic flash – The left turn signal is switched on.
	The idle indicator lamp lights up green – The transmission is in idle.

	The right turn signal lamp flashes green with a steady rhythmic flash – The right turn signal is switched on.
	The engine warning lamp lights up/flashes yellow – The engine control unit has detected a fault.
	The ABS lamp lights up/flashes yellow – ABS is not active. The ABS lamp also lights up if an error is detected.
	The TC lamp lights up/flashes yellow – Traction control is not enabled or is currently intervening. The TC lamp also lights up if an error is detected.





## 7.7 Message on the matrix display



### Possible states

	Engine malfunction – The engine control unit has detected a fault. Visit an authorized KTM workshop.
	General message – General message on operating safety. Visit an authorized KTM workshop.
	ABS warning – ABS is not available. Visit an authorized KTM workshop.
	Traction control – Traction control is not available. Visit an authorized KTM workshop.
	Engine oil pressure – Engine oil pressure is too low. Switch off the engine immediately. Contact an authorized KTM workshop.
	Lighting system – An element of the lighting system has failed. Change the faulty light, or visit an authorized KTM workshop.
	Cooling water temperature – The cooling water temperature is too high. Switch off the engine. Contact an authorized KTM workshop.



	Fuel reserve – The fuel supply is dwindling. Refuel at the next opportunity.
	Icy road symbol – The roads may be icy. Adjust your speed to the road conditions.
	Battery voltage – The battery voltage is too low. Recharge the battery with a suitable battery charger.
	Service – A service is due. Contact an authorized KTM workshop.
	Emergency OFF switch – The emergency OFF switch is off.

The messages are displayed in the **"Warning"** menu.

## 7.8 Shift warning light

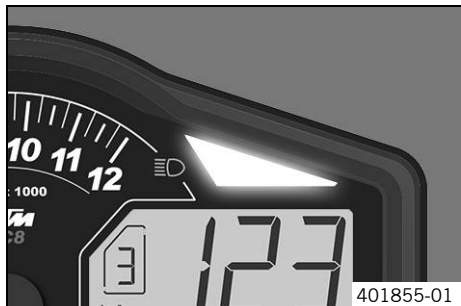

The shift warning light flashes or lights up when the transmission should be shifted. In the **"Shift Light"** menu, the engine speed for the shift warning light can be set. The shift warning light flashes over **"RPM1"** and lights up continuously over **"RPM2"**.



### Info

In 6th gear, the shift warning light is deactivated when the engine is warm after the first service.

The shift warning light can be turned on and off in the **"Settings"** menu.

Engine oil temperature	> 35 °C (> 95 °F)
<b>"ODO"</b>	> 1,000 km (> 620 mi)
The shift warning light flashes	> <b>"RPM1"</b>

# 7 COMBINATION INSTRUMENT

The shift warning light is continuously lit	> "RPM2"
Engine oil temperature	$\leq 35\text{ }^{\circ}\text{C}$ ( $\leq 95\text{ }^{\circ}\text{F}$ )
"ODO"	< 1,000 km (< 620 mi)
The shift warning light always lights up at	6,500 rpm

## 7.9 service display



F00706-01

After the ignition is switched on, the service display appears briefly. The service intervals depend on the distance traveled or the elapsed time. The event that occurs first is given priority. The exact service intervals can be found in the service schedule.

## 7.10 Matrix display menu

### 7.10.1 "Favorites"

Favorites	
Trip 1	486km
ODO	677km
Fuel Range	240km
Trip Time 2	15:23h
Battery	13.0V

401988-01

- Press the **UP** or **DOWN** button until the **"Favorites"** menu appears on the matrix display. Pressing the **SET** button opens the menu.
- Press the **UP** or **DOWN** button to select the menu item and activate it with the **SET** button.
- Pressing the **BACK** button twice always opens the **"Favorites"** menu.

In the **"Favorites"** menu, you can directly open five menus.

In the **"Set Favorites"** menu, the **"Favorites"** menu can be configured.

### 7.10.2 "Trip 1"

Trip 1	
Trip 1	973km
Ø Speed 1	89km/h
Ø Cons 1	7.3l
Trip Time 1	15:23h
Fuel Range	240km

L02906-01

- Press the **UP** or **DOWN** button until the **"Trip 1"** menu appears on the matrix display. **"Trip 1"** shows the distance since the last reset, such as between two refueling stops. **"Trip 1"** runs continuously and counts the distance up to **9999**. **"Ø Speed 1"** indicates the average speed based on **"Trip 1"** and **"Trip Time 1"**. **"Ø Cons 1"** indicates the average fuel consumption based on **"Trip 1"** and **"Trip Time 1"**. **"Trip Time 1"** indicates the riding time based on **"Trip 1"** and starts running as soon as a speed signal comes in. **"Fuel Range"** indicates the possible range with the fuel reserve.

Press and hold the button **SET** for 3–5 seconds.

All entries in the **"Trip 1"** menu are cleared.

## 7.10.3 "Trip 2"

### Trip 2

Trip 2	973km
Ø Speed 2	89km/h
Ø Cons 2	7.3l
Trip Time 2	15:23h
Fuel Range	240km

L02907-01

- Press the **UP** or **DOWN** button until the **"Trip 2"** menu appears on the matrix display. **"Trip 2"** shows the distance since the last reset, such as between two refueling stops. **"Trip 2"** runs continuously and counts the distance up to **9999**. **"Ø Speed 2"** indicates the average speed based on **"Trip 2"** and **"Trip Time 2"**. **"Ø Cons 2"** indicates the average fuel consumption based on **"Trip 2"** and **"Trip Time 2"**. **"Trip Time 2"** indicates the riding time based on **"Trip 2"** and starts running as soon as a speed signal comes in. **"Fuel Range"** indicates the possible range with the fuel reserve.

Press and hold the button **SET** for 3–5 seconds.

All entries in the **"Trip 2"** menu are cleared.

## 7.10.4 "General Info"

### General Info

Air Temp	14.0°C
Date	01.04.2017
ODO	677km
Battery	13.0V
Oil Temp	

F00705-01

- Press the **UP** or **DOWN** button until the **"General Info"** menu appears on the matrix display. **"Air Temp"** displays the ambient air temperature. **"Date"** displays the date. **"ODO"** displays the total distance covered. **"Battery"** displays the battery voltage. **"Oil Temp"** - inoperative

## 7.10.5 "Set Favorites"

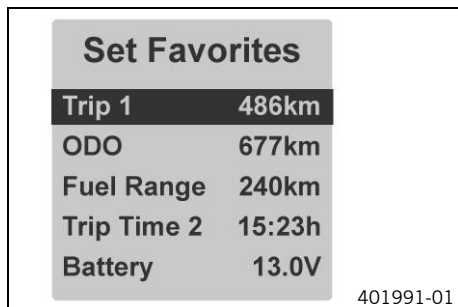

### Condition

- The vehicle is stationary.
- Press the **UP** or **DOWN** button until the "**Set Favorites**" menu appears on the matrix display. Pressing the **SET** button opens the menu.
- Press the **UP** or **DOWN** button to select the menu. Press the **SET** button to set the menu for quick selection.

In the "**Set Favorites**" menu, the "**Favorites**" menu can be configured.

## 7.10.6 "Settings"

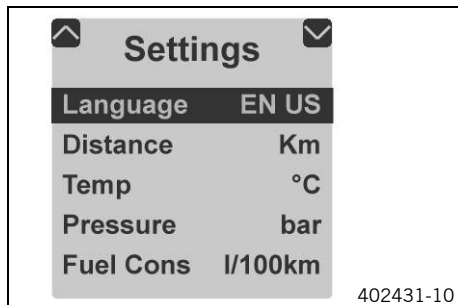

### Condition

- The vehicle is stationary.
- Press the **UP** or **DOWN** button until the "**Settings**" menu appears on the matrix display. Pressing the **SET** button opens the menu.

Settings for units or various values are made in the "**Settings**" menu. Several functions can be enabled or disabled.

## 7.10.7 "Warning"

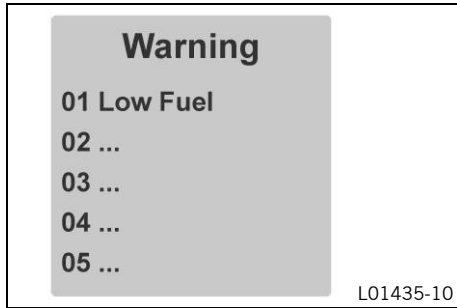

### Condition

- Message or warning
  - Press the **UP** or **DOWN** button until the "**Warning**" menu appears on the matrix display. Pressing the **SET** button opens the menu.
  - Use the **UP** or **DOWN** button to navigate through the warnings.

In the "**Warning**" menu, warnings that occurred are displayed and stored until they are no longer active.

## 7.10.8 "Heating" (optional)

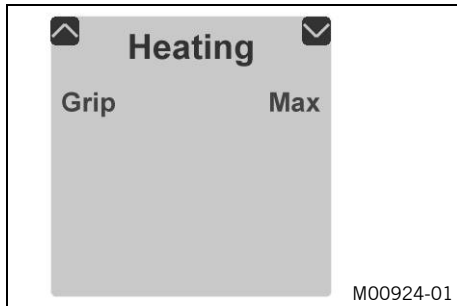

- Press **UP** or **DOWN** button until the "**Heating**" menu appears on the matrix display. Pressing the **SET** button opens the menu.
- Use the **SET** button to select a heating level or to switch off the heated grips.

## 7.10.9 "MTC/ABS"

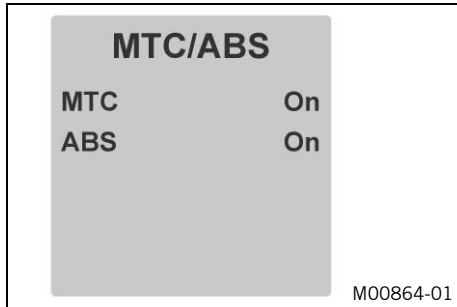

### Condition

- The vehicle is stationary.



### Warning

**Voiding of the government approval for road use and the insurance coverage** If the ABS is switched off completely, the vehicle's approval for road use is invalidated.

- Only operate the vehicle in closed-off areas remote from public road traffic if the ABS is switched off completely.

- Press the **UP** or **DOWN** button until the "**MTC/ABS**" menu appears on the matrix display. In the "**MTC/ABS**" menu, the traction control "**TC**" and the "**ABS**" can be switched off.



### Info

After the ignition is switched on, traction control and ABS are enabled again.

## 7.10.10 "Drive Mod"

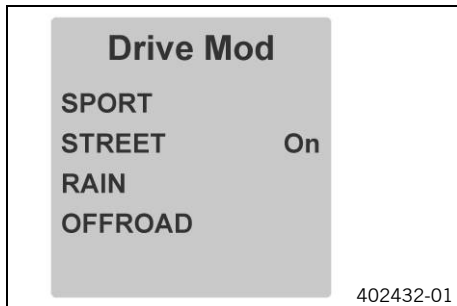

- Press the **UP** or **DOWN** button until the "**Drive Mod**" menu appears on the matrix display. Pressing the **SET** button opens the menu.
- Use the **UP** or **DOWN** button to navigate through the menu. The **SET** button can be used to select engine and traction control settings that are coordinated with each other.
  - ✓ SPORT – homologated performance with very direct response; the traction control allows greater slip on the rear wheel
  - ✓ STREET – homologated performance with balanced response; the traction control allows normal slip on the rear wheel
  - ✓ RAIN – reduced homologated performance for better rideability; the traction control allows normal slip on the rear wheel

# 7 COMBINATION INSTRUMENT

- ✓ OFFROAD (optional) – reduced homologated performance for better ridability; the traction control allows high slip on the rear wheel





## 7.10.11 Menu overview

**Trip 1**

Trip 1	973km
Ø Speed 1	89km/h
Ø Cons 1	10.3l
Trip Time 1	15:23h
Fuel Range	240km

**Trip 2**

Trip 2	973km
Ø Speed 2	89km/h
Ø Cons 2	10.3l
Trip Time 2	15:23h
Fuel Range	240km

**General Info**

Air Temp	14.0°C
Date	01.04.2017
ODO	677km
Battery	13.0V
Oil Temp	75°C

**Set Favorites**

Trip 1	486km
Trip 2	973km
Fuel Range	240km
Trip Time 2	15:23h
Battery	13.0V

**Favorites**

Trip 1	486km
Trip 2	973km
Fuel Range	240km
Trip Time 2	15:23h
Battery	13.0V

**Settings**

Language	EN US
Distance	Km
Temp	°C
Volume	litre
Pressure	bar

**Drive Mod**

SPORT	
STREET	On
RAIN	
OFFROAD	

**MTC/ABS**

MTC	On
ABS	On

**Heating**

Grip	Max
------	-----

**Warnings**

01 Low Fuel
02 ...
03 ...
04 ...
05 ...

---

"KTM" start screen

---

Menu buttons

---

"Favorites"

---

"Trip 1"

---

"Trip 2"

---

"General Info"

---

"Set Favorites"

---

"Settings"

---

"Warning" (only active if there are messages)

---

"Heating" (optional)

---

"MTC/ABS"

---

"Drive Mod"

---

## 7.10.12 "Language"

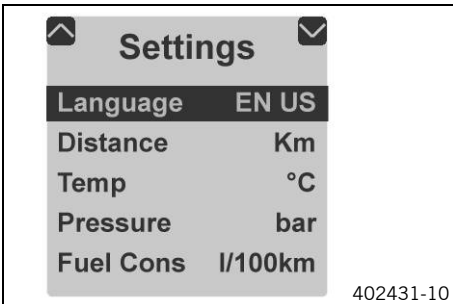

### Condition

- The vehicle is stationary.
- Press the **UP** or **DOWN** button until the "**Settings**" menu appears on the matrix display. Pressing the **SET** button opens the menu.
- Press the **SET** button again to select the language.

The menu languages are US English, UK English, German, Italian, French, and Spanish.

## 7.10.13 "Distance"

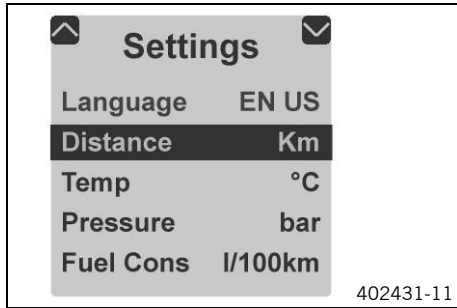

### Condition

- The vehicle is stationary.
- Press the **UP** or **DOWN** button until the "**Settings**" menu appears on the matrix display. Pressing the **SET** button opens the menu.
- Press the **UP** or **DOWN** button until "**Distance**" is highlighted in black on the matrix display. Pressing the **SET** button again sets the unit of measure.

Select kilometers "**km**" or miles "**mi**" for the distance.

## 7.10.14 "Temp"

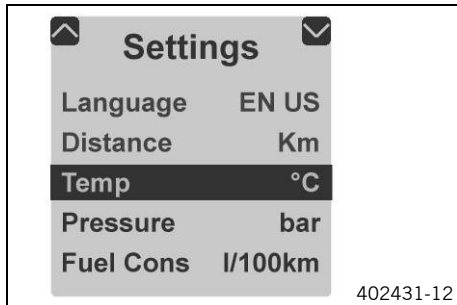

### Condition

- The vehicle is stationary.
- Press the **UP** or **DOWN** button until the "**Settings**" menu appears on the matrix display. Pressing the **SET** button opens the menu.
- Press the **UP** or **DOWN** button until "**Temp**" is highlighted in black on the matrix display. Pressing the **SET** button again sets the unit of measure.

Select "**C**" or "**F**" for the temperature indicator.

## 7.10.15 "Pressure"

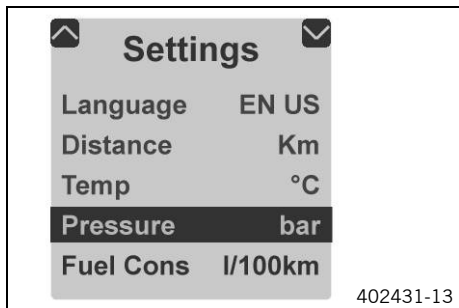

### Condition

- The vehicle is stationary.
- Press the **UP** or **DOWN** button until the "**Settings**" menu appears on the matrix display. Pressing the **SET** button opens the menu.
- Press the **UP** or **DOWN** button until "**Pressure**" is highlighted in black on the matrix display. Pressing the **SET** button again sets the unit of measure.

Select "**bar**" or "**psi**" as the unit.

## 7.10.16 "Fuel Cons"

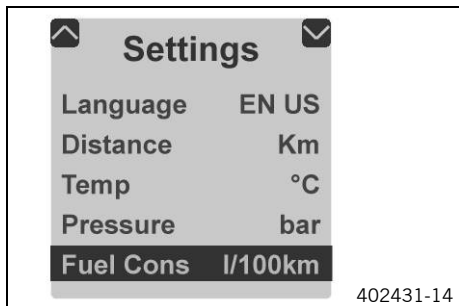

### Condition

- The vehicle is stationary.
- Press the **UP** or **DOWN** button until the "**Settings**" menu appears on the matrix display. Pressing the **SET** button opens the menu.
- Press the **UP** or **DOWN** button until "**Fuel Cons**" is highlighted in black on the matrix display. Pressing the **SET** button again sets the unit of measure.

Select one of the available consumption displays.

## 7.10.17 "Clock/Date"

Clock/Date	
Hour	12
Minute	0
Day	1
Month	1
Year	2015

M00925-01

### Condition

- The vehicle is stationary.
- Press the **UP** or **DOWN** button until the **"Settings"** menu appears on the matrix display. Pressing the **SET** button opens the menu.
- Press the **UP** or **DOWN** button until **"Clock/Date"** is highlighted in black on the matrix display. Pressing the **SET** button again opens the menu.
- Use the **UP** or **DOWN** button to navigate through the menu. Use the **SET** button to set the time and date.

If the battery was removed, the time and date must be set in the matrix display.

## 7.10.18 "Shift Light"

Shift Light	
RPM1	8000
RPM2	8250
Shift Light	on

M00926-01

### Condition

- The vehicle is stationary.
- Press the **UP** or **DOWN** button until the **"Settings"** menu appears on the matrix display. Pressing the **SET** button opens the menu.
- Press the **UP** or **DOWN** button until **"Shift Light"** is highlighted in black on the matrix display. Pressing the **SET** button again opens the menu.
- Press the **UP** or **DOWN** button to select the function. Use the **SET** button to set the engine speed for the shift warning light.

When the engine speed reaches **"RPM 1"**, the shift warning light flashes.

When the engine speed reaches **"RPM 2"**, the shift warning light lights up continuously.

Switch the **"Shift Light"** function on or off.

## 7.10.19 "Heat Grip" (optional)

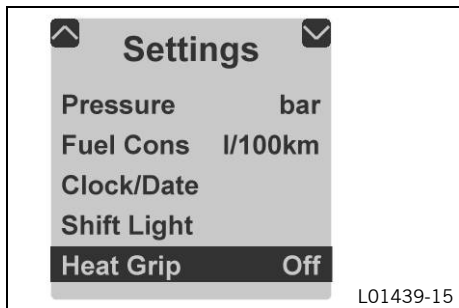

### Condition

- The vehicle is stationary.
  - Press the **UP** or **DOWN** button until the "**Settings**" menu appears on the matrix display. Pressing the **SET** button opens the menu.
  - Press the **UP** or **DOWN** button until "**Heat Grip**" is highlighted in black on the matrix display. Pressing the **SET** button again switches the heated grips menu on or off.
- Switch the heated grips menu on and off.

## 7.10.20 "DRL"

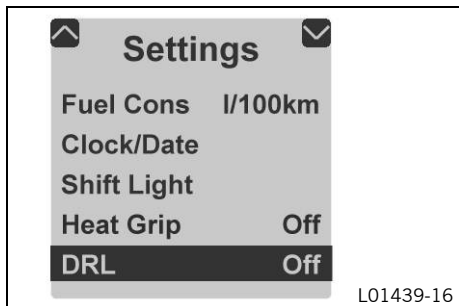

### Condition

- The vehicle is stationary.
- Press the **UP** or **DOWN** button until the "**Settings**" menu appears on the matrix display. Pressing the **SET** button opens the menu.

**Warning**

**Danger of accidents** When visibility is poor, the daytime running light is not a substitute for the low beam.

Automatic switching between the daytime running light and low beam may only be partially available when visibility is significantly impaired due to fog, snow or rain.

- Ensure that the appropriate type of lighting is always selected.
  - If necessary switch off the daytime running lights using the menu before going on a ride or when stopped so that the low beam is switched on permanently.
  - Note the legal regulations regarding the daytime running light.
- 
- Press the **UP** or **DOWN** button until "**DRL**" is highlighted in black on the matrix display. Pressing the **SET** button again switches the daytime running light on or off.

Switch the daytime running light on or off.



## 8.1 Handlebar position

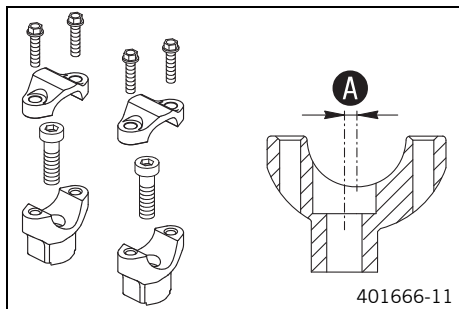

The holes on the handlebar support are placed at a distance of **A** from the center.

Hole distance <b>A</b>	3.5 mm (0.138 in)
------------------------	-------------------

The handlebar can be mounted in two different positions. In this way, the handlebar can be mounted in the position that is most comfortable for the rider.

## 8.2 Adjusting the handlebar position ↴



### Warning

**Danger of accidents** A repaired handlebar poses a safety risk.

If the handlebar is bent or straightened, the material becomes fatigued. The handlebar may break as a result.

- Change the handlebar if the handlebar is damaged or bent.

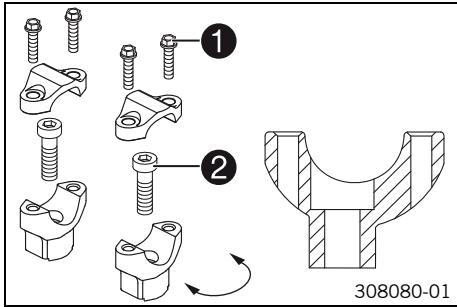

- Remove screws ❶. Remove the handlebar clamps. Remove the handlebar and lay it to one side.



**Info**

Cover the components to protect them against damage.  
Do not bend the cables and lines.

- Remove screws ❷. Take off the handlebar supports.
- Place the handlebar supports in the required position. Mount and tighten screws ❷.

Guideline

Screw, handlebar support	M10	40 Nm (29.5 lbf ft)	Loctite® 243™
--------------------------	-----	------------------------	---------------



**Info**

Position the left and right handlebar supports evenly.

- Position the handlebar.



**Info**

Make sure the cables and wiring are positioned correctly.

- Position the handlebar clamps. Mount and evenly tighten screws ❶.

Guideline

Screw, handlebar clamp	M8	20 Nm (14.8 lbf ft)
------------------------	----	------------------------



**Info**

Make sure the gap widths are even.

## 8.3 Adjusting the wind shield

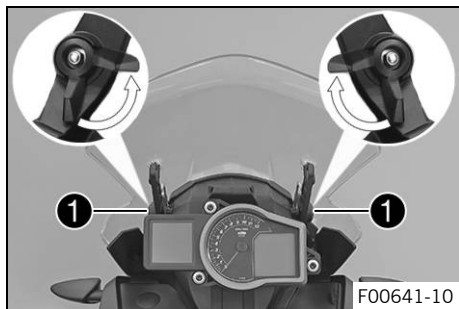

- Pull the clamping lever **1** in the direction of the arrow.  
✓ The windshield is unlocked.

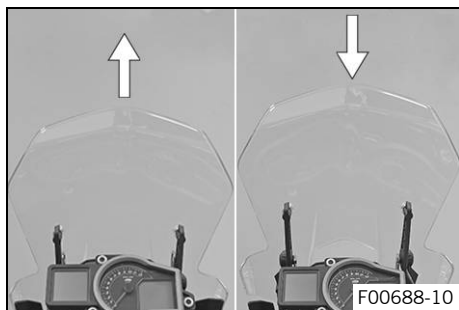

- Move the wind shield in the required position.

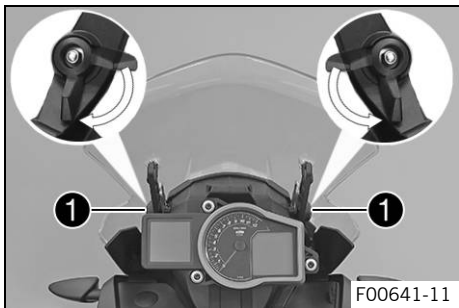

- Push the clamping lever ❶ in the direction of the arrow.  
✓ The windshield is locked.

## 8.4 Adjusting basic position of clutch lever

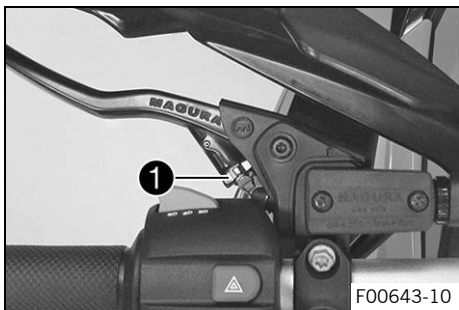

- Adjust the basic setting of the clutch lever to your hand size by turning adjusting screw ❶.

### **i** Info

Turn the adjusting screw clockwise to increase the distance between the clutch lever and the handlebar.  
Turn the adjusting screw counterclockwise to decrease the distance between the clutch lever and the handlebar.  
The range of adjustment is limited.  
Turn the adjusting screw by hand only, and do not apply any force.  
Do not make any adjustments while riding!

## 8.5 Adjusting the basic position of the hand brake lever

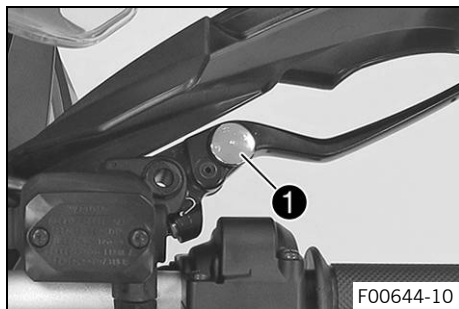

- Adjust the basic position of the hand brake lever to your hand size by turning adjusting wheel ①.

### **i** Info

Push the hand brake lever forward and turn the adjusting wheel.  
Do not make any adjustments while riding.

## 8.6 Rider footrests

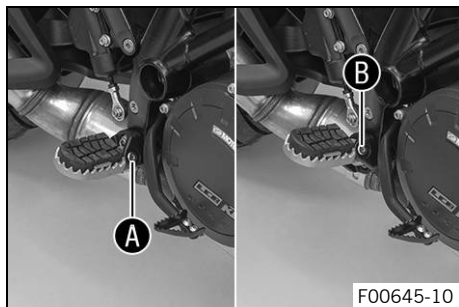

The rider footrests can be mounted in one of two positions.

### **Possible states**

- Rider footrests, low ①
- Rider footrests, high ②

## 8.7 Adjusting the footrests ↘

**i** **Info**  
The operations on the footrest brackets are the same for the left and right sides.

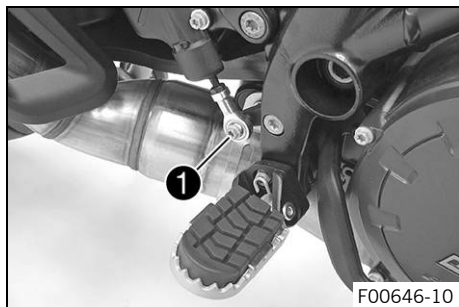

- Remove screw **1**.
- ✓ The foot brake lever swings up to the stop.

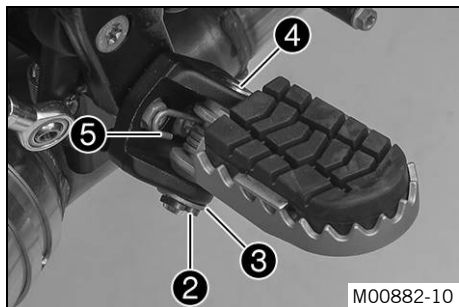

- Remove cotter pin **2** with washer **3**.
- Carefully remove the pin **4** of the rider footrest.

**i** **Info**  
The spring is under high tension and can pop out when the pin is removed.

- Take off the rider footrest **5** with the spring.

# 8 ERGONOMICS

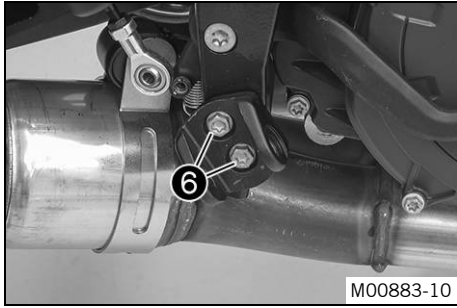

- Remove screws ⑥.

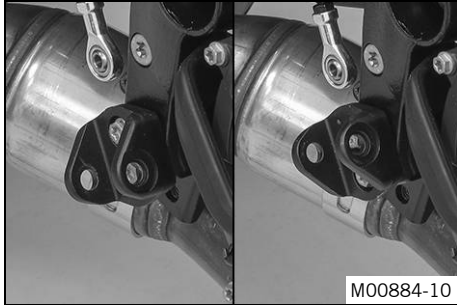

- Adjust the footrest bracket to the desired position.

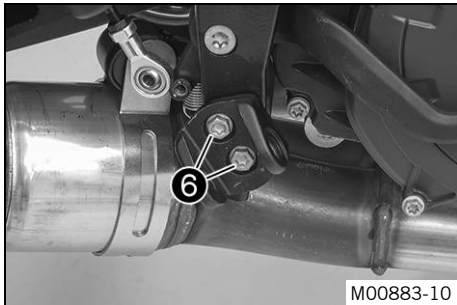

- Mount and tighten screws ⑥.

Guideline

Screw, front footrest bracket	M8	25 Nm (18.4 lbf ft)	Loctite® 243™
-------------------------------	----	------------------------	---------------

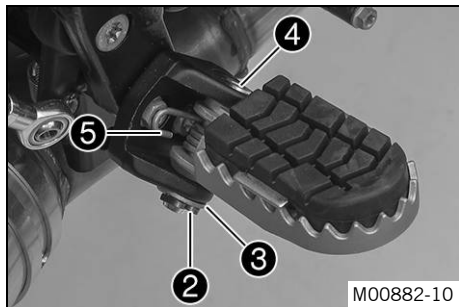

- Mount the rider footrest with spring ⑤ and pin ④.

Pliers for footrest spring (58429083000)

- Mount washer ③ and cotter pin ②.

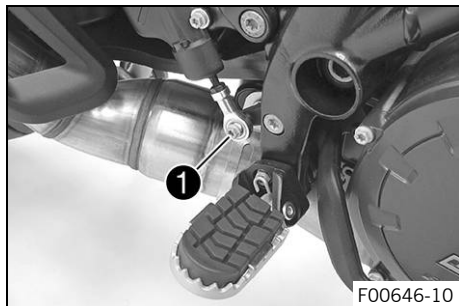

- Position the foot brake lever.
- Mount and tighten screw ①.

Guideline

Screw, ball joint of push rod on foot brake cylinder	M6	10 Nm (7.4 lbf ft)	Loctite® 243™
--	----	-----------------------	---------------

## 8.8 Checking the basic position of the shift lever



### Info

When driving, the shift lever must not touch the driver's boot when in the basic position. When the shift lever keeps touching the boot, the transmission will be subject to an excessive load.



# 8 ERGONOMICS

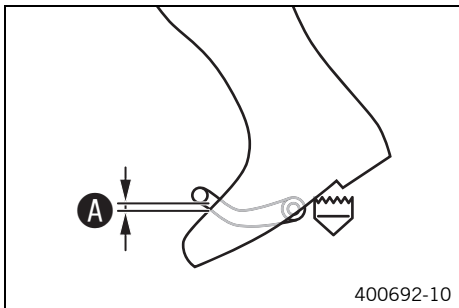

- Sit on the vehicle in the riding position and determine distance **A** between the upper edge of your boot and the shift lever.

Distance between shift lever and upper edge of boot	10... 20 mm (0.39... 0.79 in)
---	-------------------------------

- » If the distance does not meet specifications:
  - Adjust the basic position of the shift lever. 🛠️ (📖 p. 71)

## 8.9 Adjusting the basic position of the shift lever 🛠️

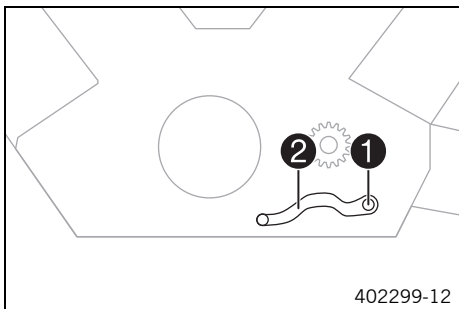

- Remove screw **1** with the washers and take off shift lever **2**.

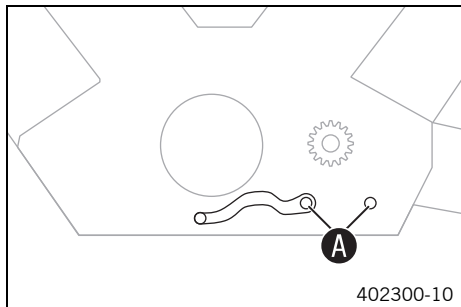

- Clean gear teeth **A** of the shift lever and shift shaft.
- Mount the shift lever on the shift shaft in the required position and engage the gearing.



**Info**

The range of adjustment is limited.  
The shift lever must not come into contact with any other vehicle components during the shift procedure.

- Mount and tighten screw **1** with the washers.

Guideline

Screw, shift lever	M6	15 Nm (11.1 lbf ft)	Loctite® 243™
--------------------	----	------------------------	---------------

## 8.10 Adjusting the basic position of the foot brake lever ↘

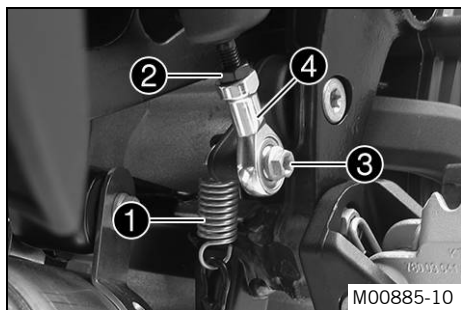

- Disconnect spring **1**.
- Loosen nut **2**.
- Remove screw **3**.
- To adjust the basic position of the foot brake lever to individual requirements, turn ball joint **4** accordingly.



**Info**

The range of adjustment is limited.  
The screw must be screwed into the ball joint by at least 5 turns.

- Hold ball joint **4** and tighten nut **2**.

Guideline

Remaining chassis nuts	M6	10 Nm (7.4 lbf ft)
------------------------	----	--------------------

- Mount and tighten screw ③.

Guideline

Screw, ball joint of push rod on foot brake cylinder	M6	10 Nm (7.4 lbf ft)	<b>Loctite® 243™</b>
--	----	-----------------------	----------------------

- Attach spring ①.

## 9.1 Advice on first use



### Danger

**Danger of accidents** A rider who is not fit to ride poses a danger to him or herself and others.

- Do not operate the vehicle if you are not fit to ride due to alcohol, drugs or medication.
- Do not operate the vehicle if you are physically or mentally impaired.



### Warning

**Risk of injury** Missing or poor protective clothing presents an increased safety risk.

- Wear appropriate protective clothing such as helmet, boots, gloves as well as trousers and a jacket with protectors on all rides.
- Always wear protective clothing that is in good condition and meets the legal regulations.



### Warning

**Danger of crashing** Different tire tread patterns on the front and rear wheel impair the handling characteristic. Different tire tread patterns can make the vehicle significantly more difficult to control.

- Make sure that only tires with a similar tire tread pattern are fitted to the front and rear wheel.



### Warning

**Danger of accidents** Non-approved or non-recommended tires and wheels impact the handling characteristic.

- Only use tires/wheels approved by KTM with the corresponding speed index.



### Warning

**Danger of accidents** New tires have reduced road grip. The contact surface on new tires is not yet roughened.

- Run in new tires with moderate riding at alternating angles.

Running-in phase

200 km (124 mi)



## Warning

**Danger of accidents** The brake system fails in the event of overheating.  
If the foot brake lever is not released, the brake linings drag continuously.

- Take your foot off the foot brake lever when you are not braking.



## Info

When using your vehicle, remember that others may feel disturbed by excessive noise.

- Make sure that the pre-delivery inspection work has been carried out by an authorized KTM workshop.
  - ✓ You receive a delivery certificate and the Service and Warranty Booklet at vehicle handover.
- Before your first trip, read the entire Owner's Manual carefully.
- Get to know the controls.
- Adjust the motorcycle to your requirements, as described in the "Ergonomics" chapter.
- Get used to handling the motorcycle on a suitable piece of land before making a longer trip. Try also to ride as slowly as possible and in a standing position to get a better feeling for the motorcycle.
- Hold the handlebar firmly with both hands and keep your feet on the footrests when riding.
- Run the engine in.

## 9.2 Running in the engine

- During the running-in phase, do not exceed the specified engine speed.

Guideline

Maximum engine speed	
During the first: 1,000 km (620 mi)	6,500 rpm
After the first: 1,000 km (620 mi)	8,500 rpm

- Avoid fully opening the throttle!



## Info

If the maximum engine speed is exceeded before the first service, the shift warning light flashes.

## 9.3 Loading the vehicle



### Warning

**Danger of accidents** Total weight and axle loads influence the handling characteristic.

The overall weight consists of: motorcycle ready for operation and with a full tank, driver and passenger with protective clothing and helmet, and luggage.

- Do not exceed the maximum permissible overall weight or the axle loads.



### Warning

**Danger of accidents** Improper mounting of cases or the tank rucksack impairs the handling characteristic.

- Mount and secure cases and tank rucksack according to the manufacturer's instructions.



### Warning

**Danger of accidents** Unstable handling characteristics at high speed.

- Adapt your speed according to your payload. Ride more slowly if your motorcycle is loaded with cases or other baggage.  
Maximum speed with luggage 150 km/h (93.2 mph)



### Warning

**Danger of accidents** The luggage system will be damaged if it is overloaded.

- Read the manufacturer information on maximum payload when mounting cases.

**Warning**

**Danger of accidents** Luggage which has slipped impairs visibility.

If the tail light is covered, you are less visible to traffic behind you, especially when it is dark.

- Check that your luggage is fixed properly at regular intervals.

**Warning**

**Danger of accidents** A high payload alters the handling characteristic and increases the stopping distance.

- Adapt your speed to your payload.

**Warning**

**Danger of accidents** Pieces of luggage which have slipped impair the handling characteristic.

- Check that your luggage is fixed properly at regular intervals.

**Warning**

**Fire hazard** The hot exhaust system may burn luggage.

- Fasten your luggage in such a way that it cannot be burned or singed by the hot exhaust system.

- 
- If you are carrying baggage, make sure it is fixed firmly as close as possible to the center of the vehicle and ensure even weight distribution between the front and rear wheels.
  - Do not exceed the maximum permitted total weight and the axle loads.

**Guideline**

Maximum permissible total weight	450 kg (992 lb.)
Maximum permissible front axle load	175 kg (386 lb.)
Maximum permissible rear axle load	300 kg (661 lb.)

## 10.1 Checks and maintenance measures when preparing for use



### Info

Before every trip, check the condition of the vehicle and ensure that it is roadworthy. The vehicle must be in perfect technical condition when it is being operated.

- Check the engine oil level. (📖 p. 187)
- Check the brake fluid level of the front brake. (📖 p. 132)
- Check the rear brake fluid level. (📖 p. 135)
- Check the front brake linings. (📖 p. 134)
- Check the rear brake linings. (📖 p. 138)
- Check that the brake system is functioning properly.
- Check the coolant level in the compensating tank. (📖 p. 181)
- Check the chain for dirt. (📖 p. 102)
- Check the chain tension. (📖 p. 103)
- Check the tire condition. (📖 p. 151)
- Check the tire air pressure. (📖 p. 152)
- Check the settings of all controls and ensure that they can be operated smoothly.
- Check that the electrical equipment is functioning properly.
- Check that luggage is properly secured.
- Check the setting of the rear mirror.
- Check the fuel level.



## 10.2 Starting



### Danger

**Danger of poisoning** Exhaust gases are toxic and inhaling them may result in unconsciousness and death.

- Always make sure there is sufficient ventilation when running the engine.
- Use an effective exhaust extraction system when starting or running the engine in an enclosed space.



### Caution

**Danger of accidents** Electronic components and safety devices will be damaged if the battery is discharged or missing.



- Never operate the vehicle with a discharged battery or without a battery.

### Note

**Engine damage** High revving speed with a cold engine negatively impacts the lifespan of the engine.

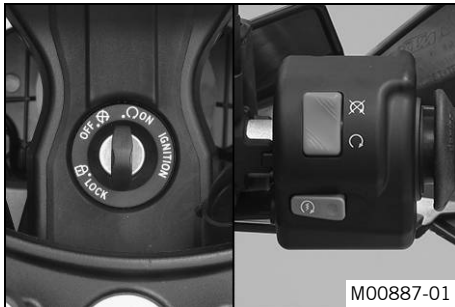
- Always run the engine warm at a low speed.



- Press the emergency OFF switch to the position **ON** .
- Switch on the ignition by turning the black ignition key to the position **ON** .
- ✓ After you switch on the ignition, you can hear the fuel pump working for about two seconds. The function check of the combination instrument is run at the same time.
- ✓ The ABS lamp lights up and goes back out after starting off.
- Shift the transmission to idle **N**.
- ✓ The green idling speed indicator lamp **N** lights up.



- Press the electric starter button (⚡).

## **i** Info

Do not press the electric starter button until the combination instrument function check is finished.

When starting, **DO NOT** open the throttle. If you open the throttle during the starting procedure, fuel is not injected by the engine management system and the engine cannot start.

Press the electric starter button (⚡) for at most 5 seconds. Wait for at least 5 seconds before trying again.

This motorcycle is equipped with a safety starting system. You can only start the engine if the transmission is in neutral or if the clutch lever is pulled when a gear is engaged. If the side stand is folded out and you shift into gear, the engine stops.

- Remove the motorcycle from the side stand.

## 10.3 Starting off

- Pull the clutch lever, engage 1st gear, release the clutch lever slowly and simultaneously open the throttle carefully.

## 10.4 Shifting, riding



### **Warning**

**Danger of accidents** Abrupt load alterations can cause the vehicle to get out of control.

- Avoid abrupt load alterations and sudden braking actions.
- Adapt your speed to the road conditions.



### **Warning**

**Danger of accidents** If you change down at high engine speed, the rear wheel blocks and the engine races.

- Do not change into a low gear at high engine speed.



## Warning

**Danger of accidents** An incorrect ignition key position causes malfunctions.

- Do not change the ignition key position while driving.



## Warning

**Danger of accidents** Adjustments to the vehicle distract attention from traffic activity.

- Make all adjustments when the vehicle is at a standstill.



## Warning

**Risk of injury** The passenger may fall from the motorcycle if they conduct themselves incorrectly.

- Ensure that the passenger sits correctly on the passenger seat, places his or her feet on the passenger foot rest and holds on to the rider or the grab handles.
- Note the regulations governing the minimum age of passengers in your country.



## Warning

**Danger of accidents** A risky riding style constitutes a major risk.

- Comply with traffic regulations and ride defensively and with foresight to detect sources of danger as early as possible.



## Warning

**Danger of accidents** Cold tires have reduced road grip.

- Ride the first miles carefully on every journey at moderate speed until the tires reach operating temperature.



## Warning

**Danger of accidents** New tires have reduced road grip.

The contact surface on new tires is not yet roughened.

- Run in new tires with moderate riding at alternating angles.

Running-in phase

200 km (124 mi)



## Warning

**Danger of accidents** Total weight and axle loads influence the handling characteristic.

The overall weight consists of: motorcycle ready for operation and with a full tank, driver and passenger with protective clothing and helmet, and luggage.

- Do not exceed the maximum permissible overall weight or the axle loads.



## Warning

**Danger of accidents** Pieces of luggage which have slipped impair the handling characteristic.

- Check that your luggage is fixed properly at regular intervals.



## Warning

**Danger of accidents** A fall can damage the vehicle more seriously than it may first appear.

- Check the vehicle after a fall as you do when preparing for use.

## Note

**Engine damage** Unfiltered intake air has a negative effect on the service life of the engine.

Dust and dirt will enter the engine without an air filter.

- Never start to use the vehicle without an air filter.

## Note

**Engine failure** Overheating damages the engine.

- If the coolant temperature warning is displayed, stop immediately and take care not to endanger yourself or other traffic participants in the process.
  - Allow the engine and cooling system to cool down.
  - Check and, if necessary, correct the coolant level on the cooling system while it is in a cooled state.
-



## Info

If you hear unusual noises while riding, stop immediately, switch off the engine and contact an authorized KTM workshop.

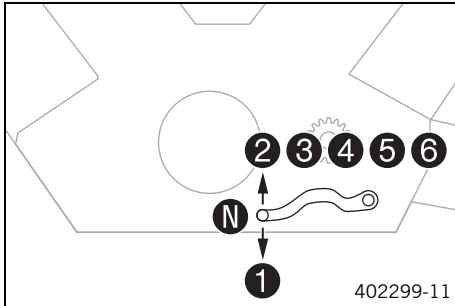



- When conditions allow (incline, road situation, etc.), you can shift into a higher gear.
- Release the throttle while simultaneously pulling the clutch lever, shift into the next gear, release the clutch lever, and open the throttle.



## Info

You can see the positions of the 6 forward gears in the figure. The idle position is between the first and second gears. First gear is used for starting off or for steep inclines.

- After reaching maximum speed by fully opening the throttle grip, turn the throttle back so it is  $\frac{3}{4}$  open. This will barely reduce the speed but fuel consumption will be considerably lower.
- Accelerate only up to a speed suitable for the road surface and weather conditions. Particularly in bends, do not shift, and accelerate very carefully.
- To shift down, brake if necessary and close the throttle at the same time.
- Pull the clutch lever and shift into a lower gear, release the clutch lever slowly, and open the throttle or shift again.
- If the engine stalls (e.g. at a crossroads), just pull the clutch lever and press the electric starter button. You do not have to shift into neutral.
- Switch off the engine if you expect to be standing for a long time.
- If the oil pressure warning lamp  lights up during a trip, stop immediately and switch off the engine. Contact an authorized KTM workshop.
- If the engine warning lamp  lights up during a trip, please contact an authorized KTM workshop as soon as possible.



## Info

From the flash rhythm you can deduce a two-digit number, the so-called blink code. The blink code tells you which component is affected by a malfunction.

- If the general warning lamp  lights up during a trip, the matrix display shows a message for 10 seconds.



## Info

Very important messages are stored in the **"Warning"** menu.

- If the icy road symbol  appears in the combination instrument, the roads may be icy. Adjust your speed to the road conditions.

## 10.5 Applying the brakes



### Warning

**Danger of accidents** Moisture and dirt impair the brake system.

- Brake carefully several times to dry out and remove dirt from the brake linings and the brake discs.



### Warning

**Danger of accidents** A spongy pressure point on the front or rear brake reduces braking efficiency.

- Check the brake system and do not continue riding until the problem is eliminated. (Your authorized KTM workshop will be glad to help.)



### Warning

**Danger of accidents** The brake system fails in the event of overheating.

If the foot brake lever is not released, the brake linings drag continuously.

- Take your foot off the foot brake lever when you are not braking.



## Warning

**Danger of accidents** Higher total weight increases the stopping distance.

- Take the longer stopping distance into account when carrying a passenger or luggage with you.



## Warning

**Danger of accidents** Salt on the roads impairs the brake system.

- Brake carefully several times to remove salt from the brake linings and the brake discs.



## Warning

**Danger of accidents** ABS may increase the stopping distance in certain situations.

- Adjust application of the brakes to the respective riding situation and riding surface conditions.



## Warning

**Danger of accidents** Excessively forceful application of the brakes blocks the wheels.  
The ABS effectiveness is only ensured if it is switched on.

- Leave the ABS switched on in order to benefit from the protective effect.



## Warning

**Danger of accidents** Driving aids can only prevent a rollover within the physical limitations.

It is not always possible to compensate for extreme riding situations, for example with luggage loaded with a high center of gravity, varying road surfaces, steep descents or full braking without disengaging the gear.

- Adapt your riding style to the road conditions and your driving ability.

- 
- When braking, release the throttle and apply the front and rear brakes at the same time.



## Info

When the **ABS** is enabled, you can achieve maximum braking power even on low grip surfaces such as sandy, wet, or slippery terrain without locking of the wheels.

---

**Warning**

**Danger of accidents** The rear wheel can lock due to the engine braking effect.

- Pull in the clutch, if you perform emergency or full braking, or if you brake on a slippery ground.

**Warning**

**Danger of accidents** Banked or laterally sloping ground reduces the maximum possible delay.

- If possible finish braking before going into a bend.

- Braking should always be completed before you go into a bend. Change down to a lower gear appropriate to your road speed.
- On long downhill stretches, use the braking effect of the engine. Change down one or two gears, but do not over-rev the engine. In this way, you have to brake far less and the brakes do not overheat.

## 10.6 Stopping, parking

**Warning**

**Risk of injury** People who act without authorization endanger themselves and others.

- Do not leave the vehicle unattended if the engine is running.
- Protect the vehicle against access by unauthorized persons.
- Lock the steering and remove the ignition key if you leave the vehicle unattended.

**Warning**

**Danger of burns** Some vehicle components become very hot when the vehicle is operated.

- Do not touch any parts such as the exhaust system, radiator, engine, shock absorber, or brake system before the vehicle parts have cooled down.
- Let the vehicle parts cool down before you perform any work on the vehicle.

**Note**

**Material damage** The vehicle may be damaged by incorrect procedure when parking.



Significant damage may be caused if the vehicle rolls away or falls over.  
The components for parking the vehicle are designed only for the weight of the vehicle.

- Park the vehicle on a firm and level surface.
- Ensure that nobody sits on the vehicle when the vehicle is parked on a stand.

## Note

**Fire hazard** Hot vehicle components pose a fire hazard and explosion risk.



- Do not park the vehicle near to materials which are highly flammable or explosive.
- Allow the vehicle to cool down before covering it.

- 
- Apply the brakes on the motorcycle.
  - Shift the transmission to idle **N**.
  - Switch off the ignition by turning the black ignition key to the position **OFF** .



## Info

If the engine is switched off with the emergency OFF switch and the ignition remains switched on at the ignition lock, power continues to flow to most power consumers. This discharges the battery. You should therefore always switch off the engine with the ignition key – the emergency OFF switch is intended for emergencies only.

- 
- Park the motorcycle on a firm surface.
  - Swing the side stand forward with your foot as far as it will go and lean the vehicle on it.
  - Lock the steering by turning the handlebar to the left, pressing the black ignition key down in the position **OFF**  and turning it to the position **LOCK** . To make the steering lock engage more easily, move the handlebar a little to the left and right. Remove the black ignition key.

## 10.7 Transport

### Note

**Danger of damage** The parked vehicle can roll away or fall over.

- Park the vehicle on a firm and level surface.

### Note

**Fire hazard** Hot vehicle components pose a fire hazard and explosion risk.

- Do not park the vehicle near to materials which are highly flammable or explosive.
- Allow the vehicle to cool down before covering it.

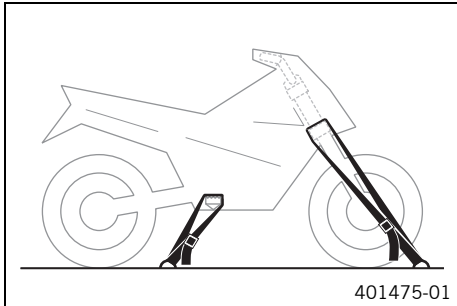

- Switch off the engine.
- Use tension belts or other suitable devices to secure the motorcycle against accidents or falling over.

## 10.8 Refueling



### **Danger**

**Fire hazard** Fuel is highly flammable.

The fuel in the fuel tank expands when warm and can escape if overfilled.

- Do not refuel the vehicle in the vicinity of open flames or lit cigarettes.
- Switch off the engine for refueling.
- Make sure that no fuel is spilled; particularly not on hot parts of the vehicle.
- If any fuel is spilled, wipe it off immediately.
- Observe the specifications for refueling.



### **Warning**

**Danger of poisoning** Fuel is poisonous and a health hazard.

- Avoid skin, eye and clothing contact with fuel.
- Immediately consult a doctor if you swallow fuel.
- Do not inhale fuel vapors.
- In case of skin contact, rinse the affected area with plenty of water.
- Rinse the eyes thoroughly with water, and consult a doctor in case of fuel contact with the eyes.
- Change your clothing in case of fuel spills on them.

### **Note**

**Material damage** Inadequate fuel quality causes the fuel filter to quickly become clogged.

In some countries and regions, the available fuel quality and cleanliness may not be sufficient. This will result in problems with the fuel system.

- Refuel only with clean fuel that meets the specified standards. (Your authorized KTM workshop will be glad to help.)



## Warning

**Environmental hazard** Improper handling of fuel is a danger to the environment.

- Do not allow fuel to enter the groundwater, the soil, or the sewage system.

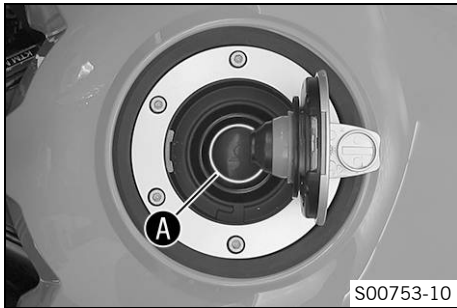

- Switch off the engine.
- Open the filler cap. (📖 p. 34)
- Fill the fuel tank with fuel up to the lower edge **A** of the filler neck.

Total fuel tank capacity, approx.	23 l (6.1 US gal)	Super unleaded (ROZ 95/RON 95/PON 91) (📖 p. 218)
-----------------------------------	-------------------	--

- Close the filler cap. (📖 p. 36)

# 11 SERVICE SCHEDULE

## 11.1 Additional information

Any further work that results from the required work or from the recommended work must be ordered separately and invoiced separately. Different service intervals may apply in your country, depending on the local operating conditions.

## 11.2 Required work

	Every two years				
	Every year				
	every 30,000 km (18,600 mi)				
	every 15,000 km (9,300 mi)				
	after 1,000 km (620 mi)				
Read out the trouble code memory using the KTM diagnostics tool. 🛠️	○	●	●	●	●
Check that the electrical system is functioning properly.	○	●	●	●	●
Change the engine oil and oil filter and clean the oil screens. 🛠️ (📖 p. 188)	○	●	●	●	●
Check the front brake linings. (📖 p. 134)	○	●	●	●	●
Check the rear brake linings. (📖 p. 138)	○	●	●	●	●
Check the brake discs. (📖 p. 131)	○	●	●	●	●
Check the brake lines for damage and leakage. 🛠️	○	●	●	●	●
Change the front brake fluid. 🛠️					●
Change the rear brake fluid. 🛠️					●
Change the hydraulic clutch fluid. 🛠️					●
Check the brake fluid level of the front brake. (📖 p. 132)	○	●	●	●	
Check the rear brake fluid level. (📖 p. 135)	○	●	●	●	
Check/correct the fluid level of the hydraulic clutch. (📖 p. 109)		●	●	●	
Check the shock absorber and fork for leaks. Perform service as needed and depending on how the vehicle is used. 🛠️	○	●	●	●	●

# 11 SERVICE SCHEDULE

		Every two years		Every year	
		every 30,000 km (18,600 mi)		every 15,000 km (9,300 mi)	
		after 1,000 km (620 mi)			
Clean the dust boots of the fork legs. 🛠️ (📖 p. 122)		•	•		
Check the play of the steering head bearing. (📖 p. 110)	○	•	•	•	•
Check the tire condition. (📖 p. 151)	○	•	•	•	•
Check the tire air pressure. (📖 p. 152)	○	•	•	•	•
Check the chain, rear sprocket, and engine sprocket. (📖 p. 106)		•	•	•	•
Check the chain tension. (📖 p. 103)	○	•	•	•	•
Change the spark plugs (air filter removed). 🛠️			•		
Check the valve clearance (air filter and spark plugs removed). 🛠️			•		
Change the SAS membrane. 🛠️			•		
Check the cables for damage and routing without sharp bends. (fuel tank removed) 🛠️		•	•	•	•
Check the coolant level in the compensating tank. (📖 p. 181)	○	•	•	•	•
Change the air filter, clean the air filter box. 🛠️		•	•		
Check the fuel pressure. 🛠️		•	•	•	•
Check the CO adjustment using the KTM diagnostics tool. 🛠️	○	•	•		
Check the headlight setting. (📖 p. 174)	○	•	•		
Check that the radiator fan is functioning properly. 🛠️	○	•	•	•	•
Final check: Check the vehicle is roadworthy and take a test ride. 🛠️	○	•	•	•	•
Read out the error memory after the test ride using the KTM diagnostics tool. 🛠️	○	•	•	•	•
Reset the service display using the KTM diagnostic tool. 🛠️	○	•	•	•	•
Make the service entry in <b>KTM Dealer.net</b> and in the Service and Warranty Booklet. 🛠️	○	•	•	•	•

# 11 SERVICE SCHEDULE

- One-time interval
- Periodic interval

## 11.3 Recommended work

		Every four years		Every year		
				every 30,000 km (18,600 mi)		
				every 15,000 km (9,300 mi)		
				after 1,000 km (620 mi)		
Check the frame. 🛠️			●			
Check the swingarm. 🛠️			●			
Check/clean the oil nozzle for clutch lubrication. 🛠️	○	●	●			
Check the swingarm bearing for backlash.		●	●			
Check the wheel bearing for play.		●	●			
Grease all moving parts (e.g., side stand, hand lever, chain, ...) and check for smooth operation. 🛠️	○	●	●	●	●	
Empty the drainage hoses. 🛠️	○	●	●	●	●	
Check all hoses (e.g. fuel, cooling, bleeder, drainage, etc.) and sleeves for cracking, leaks, and incorrect routing. 🛠️		●	●	●	●	
Check the screws and nuts for tightness. 🛠️	○	●	●	●	●	
Change the coolant. 🛠️						●
Check the antifreeze. 🛠️	○	●	●	●		

- One-time interval
- Periodic interval

## 12.1 Adjusting the rebound damping of the shock absorber



### Caution

**Risk of injury** Parts of the shock absorber will fly off if the shock absorber is disassembled incorrectly. The shock absorber is filled with highly compressed nitrogen.

- Please follow the description provided. (Your authorized KTM workshop will be glad to help.)

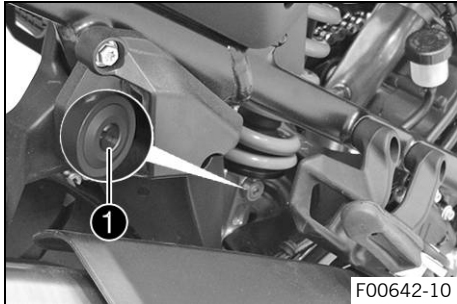

- Turn adjusting screw ❶ clockwise up to the last perceptible click.
- Turn counterclockwise by the number of clicks corresponding to the shock absorber type.

### Guideline

Rebound damping	
Standard	12 clicks



### Info

Turn clockwise to increase damping; turn counterclockwise to reduce damping.

## 12.2 Adjusting the spring preload of the shock absorber



### Caution

**Risk of injury** Parts of the shock absorber will fly off if the shock absorber is disassembled incorrectly. The shock absorber is filled with highly compressed nitrogen.

- Please follow the description provided. (Your authorized KTM workshop will be glad to help.)



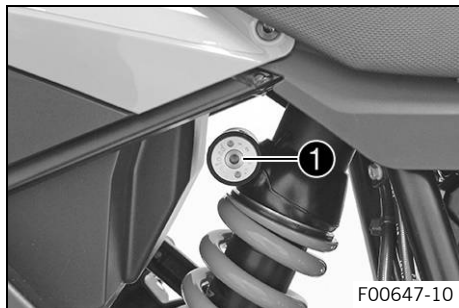

- Turn adjusting screw ❶ counterclockwise all the way.
- Turn it clockwise by the number of turns corresponding to the shock absorber type and use.

Guideline

Spring preload	
Standard	2 turns

**i** **Info** Turn clockwise to increase the spring preload; turn counterclockwise to reduce the spring preload.

## 13.1 Raising the motorcycle with the rear lifting gear

### Note

**Danger of damage** The parked vehicle can roll away or fall over.

- Park the vehicle on a firm and level surface.



- Mount lifting bushings on the swingarm.
- Insert the adapter in the rear lifting gear.

Adapter (69329955020)
-----------------------

Lifting gear, rear (61029055400)
----------------------------------

- Place the motorcycle vertically, use the adapters to direct the lifting gear towards the swingarm and lift the motorcycle.

## 13.2 Removing the rear of motorcycle from the lifting gear

### Note

**Danger of damage** The parked vehicle can roll away or fall over.

- Park the vehicle on a firm and level surface.

# 13 SERVICE WORK ON THE CHASSIS

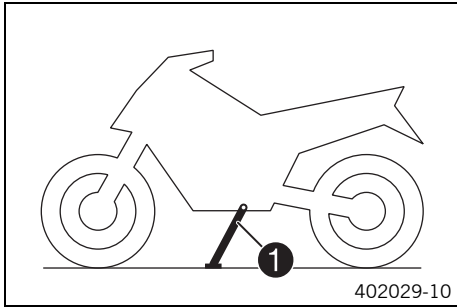

- Secure the motorcycle against falling over.
- Remove the rear lifting gear and lean the motorcycle on the side stand **1**.
- Remove the lifting bushings from the swingarm.

## 13.3 Lifting the motorcycle with the front lifting gear

### Note

**Danger of damage** The parked vehicle can roll away or fall over.

- Park the vehicle on a firm and level surface.

### Preparatory work

- Raise the motorcycle with the rear lifting gear. (📖 p. 96)
- Remove the bottom triple clamp cover. (📖 p. 111)



### Main work

- Move the handlebar to the straight-ahead position.
- Attach the front lifting gear with the adapters on the steering stem.

Mounting pin (69329965030)
----------------------------

Lifting gear, front (61029055500)
-----------------------------------

- Align the front lifting gear with the fork legs.



### Info

Always raise the motorcycle at the rear first.

- Raise the motorcycle at the front.

## 13.4 Taking the motorcycle from the front lifting gear

### Note

**Danger of damage** The parked vehicle can roll away or fall over.

- Park the vehicle on a firm and level surface.



### Main work

- Secure the motorcycle against falling over.
- Remove the front lifting gear.

## Finishing work

- Install the bottom triple clamp cover. (📖 p. 112)

### 13.5 Raising the motorcycle with the work stand (inserted) 🛠️

#### Note

**Danger of damage** The parked vehicle can roll away or fall over.

- Park the vehicle on a firm and level surface.

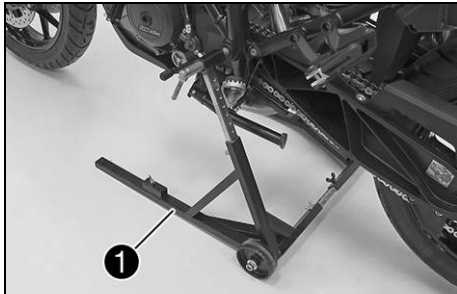

- Fold up the rider footrests and secure them.
- Allow the work stand ① with plastic bushing to engage in the opening of the swingarm pivot.

Work stand (62529055100)



#### Info

Set the work stand to an appropriate height and width.

- Raise the motorcycle.
- Check that the work stand is properly seated.



F00690-10

## 13.6 Removing the motorcycle from the work stand (inserted) ↗

### Note

**Danger of damage** The parked vehicle can roll away or fall over.

- Park the vehicle on a firm and level surface.

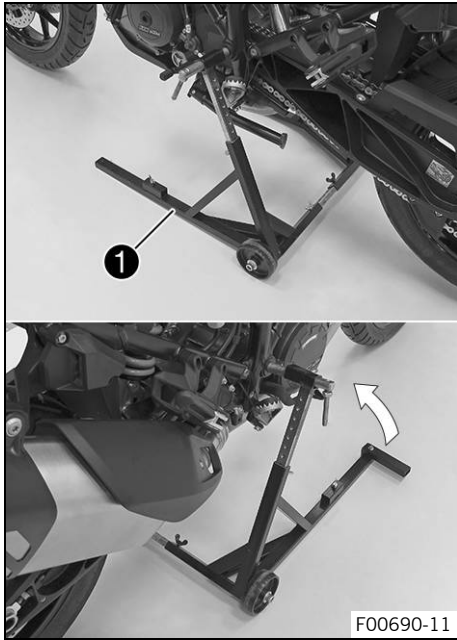

- Secure the motorcycle against falling over.
- Remove the special tool ❶.

Work stand (62529055100)

### **i** Info

To avoid damaging components, lower the motorcycle slowly from the work stand.

The assistance of a second person can be useful.

- Lean the motorcycle on the side stand.
- Remove the fixing means on the rider footrests.

## 13.7 Removing the seat

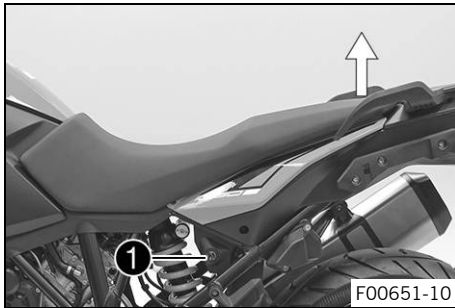

- Insert the ignition key in the seat lock **1** and turn it clockwise by 45°.
- Raise the rear of the seat, pull the seat back, and lift it off.
- Remove the ignition key.

## 13.8 Mounting the seat

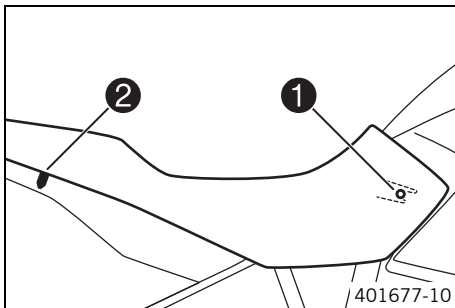

- Hook the catch **1** of the seat onto the fuel tank and lower the rear while pushing it forward.
- Insert the locking pin **2** into the lock housing and push down the rear of the seat until the locking pin engages with an audible click.
- Finally, check that the seat is correctly mounted.

## 13.9 Checking for chain dirt

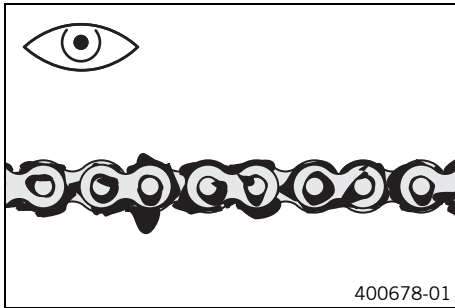

- Check the chain for coarse dirt accumulation.
  - » If the chain is very dirty:
    - Clean the chain. (📖 p. 102)

## 13.10 Cleaning the chain



### Warning

**Danger of accidents** Oil or grease on the tires reduces the road grip.

- Remove the lubricant from the tires using a suitable cleaning agent.



### Warning

**Danger of accidents** Oil or grease on the brake discs reduces the braking effect.

- Always keep the brake discs free of oil and grease.
- Clean the brake discs with brake cleaner when necessary.



### Warning

**Environmental hazard** Hazardous substances cause environmental damage.

- Dispose of oils, grease, filters, fuel, cleaning agents, brake fluid, etc., correctly and in compliance with the applicable regulations.





## Info

The service life of the chain depends largely on its maintenance.

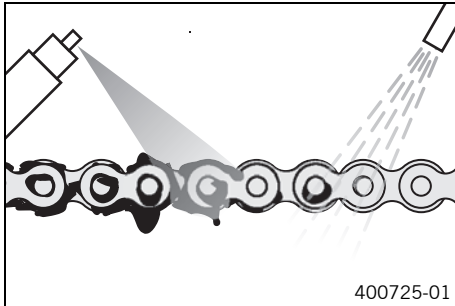

### Preparatory work

- Raise the motorcycle with the rear lifting gear. (📖 p. 96)

### Main work

- Clean the chain regularly.
- Rinse off loose dirt with a soft jet of water.
- Remove old grease remains with chain cleaner.

Chain cleaner (📖 p. 219)

- After drying, apply chain spray.

Chain lube for road use (📖 p. 219)

### Finishing work

- Remove the rear of the motorcycle from the lifting gear. (📖 p. 96)

## 13.11 Checking the chain tension



### Warning

**Danger of accidents** Incorrect chain tension damages components and results in accidents.

If the chain is tensioned too much, the chain, engine sprocket, rear sprocket, transmission and rear wheel bearings wear more quickly. Some components may break if overloaded.

If the chain is too loose, the chain may fall off the engine sprocket or the rear sprocket. As a result, the rear wheel locks or the engine will be damaged.

- Check the chain tension regularly.
- Set the chain tension in accordance with the specification.

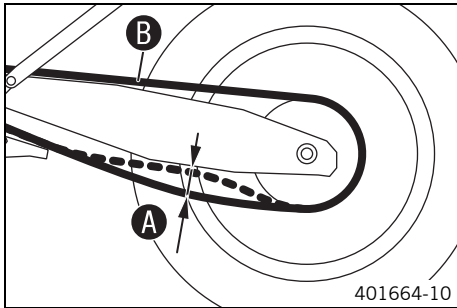

### Preparatory work

- Raise the motorcycle with the rear lifting gear. (📖 p. 96)

### Main work

- Shift the transmission to idle **N**.
- In the area in front of the chain guide, push the chain up and determine the chain tension **A**.

### **i** Info

The upper part of the chain **B** must be taut.  
Chain wear is not always even, so you should repeat this measurement at different chain positions.

Chain tension	40... 45 mm (1.57... 1.77 in)
---------------	-------------------------------

- » If the chain tension does not meet the specification:
  - Adjust the chain tension. (📖 p. 104)
- Remove the rear of the motorcycle from the lifting gear. (📖 p. 96)

## 13.12 Adjusting the chain tension



### Warning

**Danger of accidents** Incorrect chain tension damages components and results in accidents.

If the chain is tensioned too much, the chain, engine sprocket, rear sprocket, transmission and rear wheel bearings wear more quickly. Some components may break if overloaded.

If the chain is too loose, the chain may fall off the engine sprocket or the rear sprocket. As a result, the rear wheel locks or the engine will be damaged.

- Check the chain tension regularly.
- Set the chain tension in accordance with the specification.

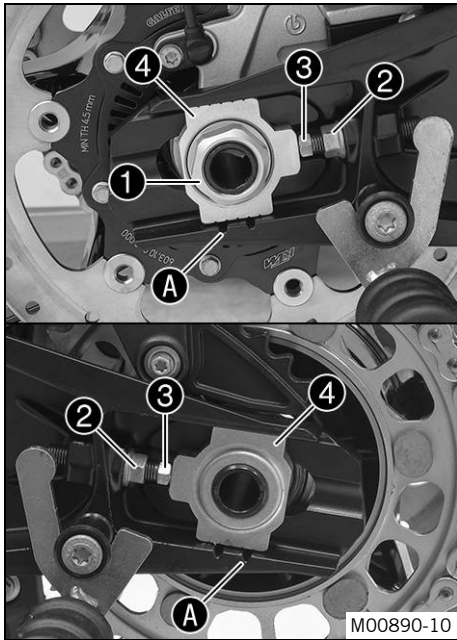

### Preparatory work

- Raise the motorcycle with the rear lifting gear. (📖 p. 96)
- Check the chain tension. (📖 p. 103)

### Main work

- Loosen nut ①.
- Loosen nuts ②.
- Adjust the chain tension by turning the adjusting screws ③ left and right.

### Guideline

Chain tension	40... 45 mm (1.57... 1.77 in)
Turn the adjusting screws ③ on the left and right so that the markings on the left and right chain adjusters ④ are in the same position relative to the reference marks A. The rear wheel is then correctly aligned.	

### **i** Info

The upper part of the chain must be taut.  
Chain wear is not always even, so you should check the setting at different chain positions.

- Tighten nuts ②.
- Make sure that chain adjusters ④ are fitted correctly on adjusting screws ③.
- Tighten nut ①.

### Guideline

Nut, rear wheel spindle	M25x1.5	90 Nm (66.4 lbf ft)	Thread greased
-------------------------	---------	------------------------	----------------

### **i** Info

Chain adjusters ④ can be turned by 180°.

## Finishing work

- Remove the rear of the motorcycle from the lifting gear. (📖 p. 96)

### 13.13 Checking the chain, rear sprocket, and engine sprocket

#### Preparatory work

- Raise the motorcycle with the rear lifting gear. (📖 p. 96)

#### Main work

- Check the rear sprocket and engine sprocket for wear.
  - » If the rear sprocket and engine sprocket are worn:
    - Change the drivetrain kit. 🛠️

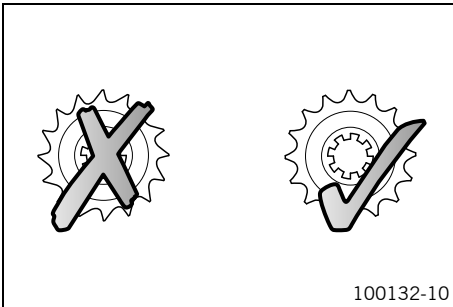

#### Info

The engine sprocket, rear sprocket, and chain should always be replaced together.

# 13 SERVICE WORK ON THE CHASSIS

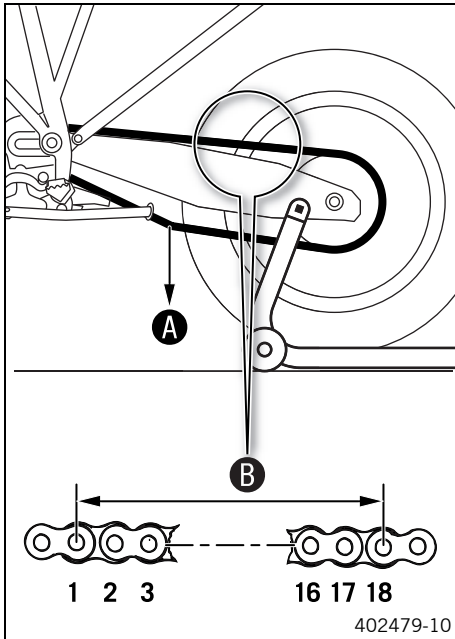

- Shift the transmission to idle **N**.
- Pull the lower chain section with the specified weight **A**.

### Guideline

Weight, chain wear measurement	15 kg (33 lb.)
--------------------------------	----------------

- Measure the distance **B** of 18 chain rollers on the upper part of the chain.

**i Info**  
Chain wear is not always even, so you should repeat this measurement at different chain positions.

Maximum distance <b>B</b> at the longest chain section	272 mm (10.71 in)
--	-------------------

- » If the distance **B** is greater than the specified measurement:
  - Change the drivetrain kit.

**i Info**  
When the chain is replaced, the rear sprocket and engine sprocket should also be changed.  
New chains wear out faster on old, worn sprockets.  
For safety reasons, the chain has no chain joint.

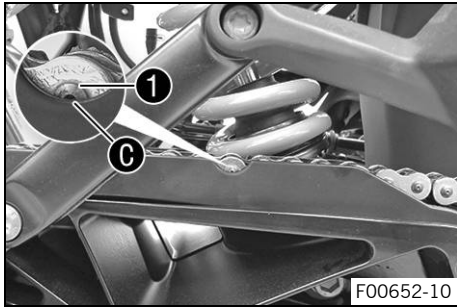

F00652-10

- Check the chain sliding guard for wear at the recess.



**Info**

When the chain sliding guard is new, the rivets **1** are half visible at the bottom edge **C** of the recess.

- » When the rivets of the chain are no longer visible at the bottom edge of the recess of the chain sliding guard:
  - Change the chain sliding guard. 🛠️
- Check that the chain sliding guard is firmly seated.
  - » If the chain sliding guard is loose:
    - Tighten the screws on the chain sliding guard.

Guideline

Screw, chain sliding guard	M5	5 Nm (3.7 lbf ft)
----------------------------	----	-------------------

- Check the chain guide for wear.
  - » If the chain guide is worn:
    - Change the chain guide. 🛠️
- Check that the chain guide is firmly seated.
  - » If the chain guide is loose:
    - Tighten the screws on the chain guide.

Guideline

Screw, chain guide	M6	5 Nm (3.7 lbf ft)
--------------------	----	-------------------

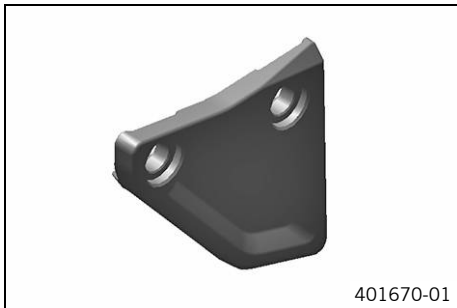

401670-01

**Finishing work**

- Remove the rear of the motorcycle from the lifting gear. (📖 p. 96)

## 13.14 Checking/correcting the fluid level of the hydraulic clutch



### Warning

**Skin irritation** Brake fluid causes skin irritation.

- Keep brake fluid out of the reach of children.
- Wear suitable protective clothing and safety glasses.
- Do not allow brake fluid to come into contact with the skin, the eyes or clothing.
- Consult a doctor immediately if brake fluid has been swallowed.
- Rinse the affected area with plenty of water in the event of contact with the skin.
- Rinse eyes thoroughly with water immediately and consult a doctor if brake fluid comes into contact with the eyes.
- If brake fluid spills on to your clothing, change the clothing.



### Warning

**Environmental hazard** Hazardous substances cause environmental damage.

- Dispose of oils, grease, filters, fuel, cleaning agents, brake fluid, etc., correctly and in compliance with the applicable regulations.



### Info

The fluid level rises with increasing wear of the clutch facing discs.

Never use DOT 5 brake fluid! It is silicone-based and purple in color. Oil seals and clutch lines are not designed for DOT 5 brake fluid.

Avoid contact between brake fluid and painted parts. Brake fluid attacks paint!

Use only clean brake fluid from a sealed container.

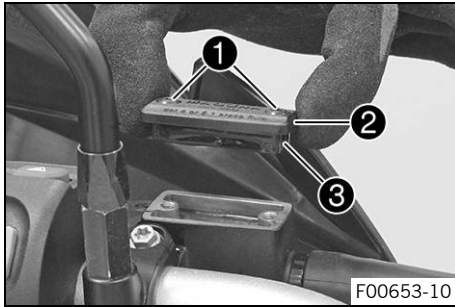

- Move the clutch fluid reservoir mounted on the handlebar to a horizontal position.
- Remove screws ①.
- Remove cover ② with membrane ③.
- Check the fluid level.

Fluid level below container rim	4 mm (0.16 in)
---------------------------------	----------------

» If the fluid level does not meet specifications:

- Correct the fluid level of the hydraulic clutch.

Brake fluid DOT 4 / DOT 5.1 (📖 p. 216)
--

- Position the cover with the membrane. Mount and tighten the screws.



### Info

Clean up overflowed or spilled brake fluid immediately with water.

## 13.15 Checking the play of the steering head bearing



### Warning

**Danger of accidents** Incorrect steering head bearing play impairs the handling characteristic and damages components.

- Correct incorrect steering head bearing play immediately. (Your authorized KTM workshop will be glad to help.)



### Info

If the vehicle is operated for a lengthy period with play in the steering head bearing, the bearings and the bearing seats in the frame can become damaged over time.

### Preparatory work

- Raise the motorcycle with the work stand (inserted). 🛠️ (📖 p. 99)



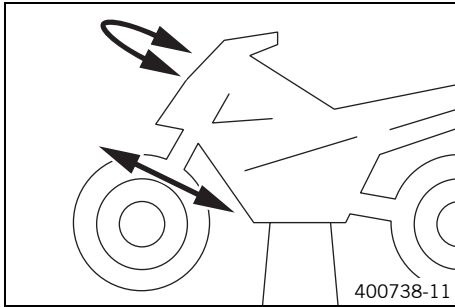

## Main work

- Place a load on the rear of the vehicle.
  - ✓ The front wheel is not in contact with the ground.
- Move the handlebar to the straight-ahead position. Move the fork legs back and forth in the direction of travel.

Play should not be detectable on the steering head bearing.

- » If there is detectable play:
  - Adjust the steering head bearing play. 🛠️
- Move the handlebar back and forth over the entire steering range.

It must be possible to move the handlebar easily over the entire steering range. There should be no detectable detent positions.

- » If detent positions are detected:
  - Adjust the steering head bearing play. 🛠️
  - Check the steering head bearing and adjust if necessary.
- Remove the motorcycle from the work stand (inserted). 🛠️ (📖 p. 100)

## 13.16 Removing the bottom triple clamp cover

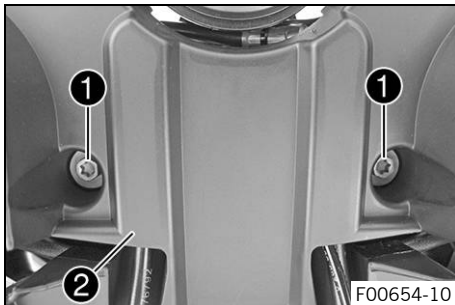

- Remove screws ①.
- Lower the triple clamp cover ② slightly.

# 13 SERVICE WORK ON THE CHASSIS

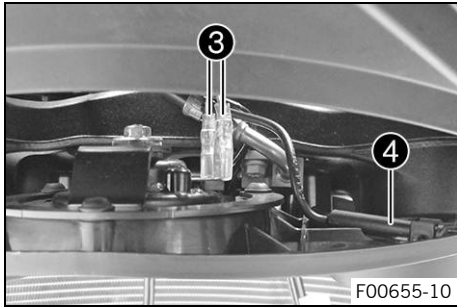

- Disconnect plugs ③ of the horn.
- Detach temperature sensor ④.
- Remove the triple clamp cover.

## 13.17 Installing the bottom triple clamp cover

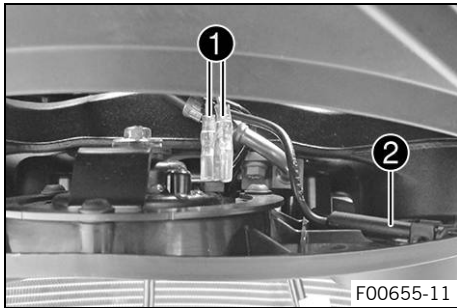

- Plug in connectors ① of the horn.
- Attach temperature sensor ②.

# 13 SERVICE WORK ON THE CHASSIS

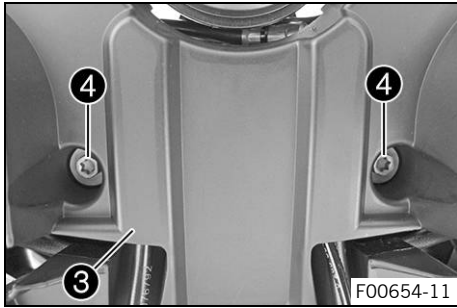

- Position the triple clamp cover ③.
- Mount and tighten screws ④.

Guideline

Remaining chassis screws	M6	10 Nm (7.4 lbf ft)
--------------------------	----	--------------------

## 13.18 Removing the front side cover

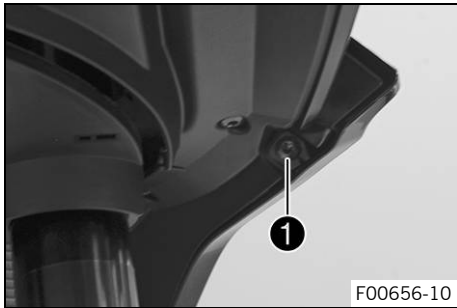

- Remove screw ①.

# 13 SERVICE WORK ON THE CHASSIS

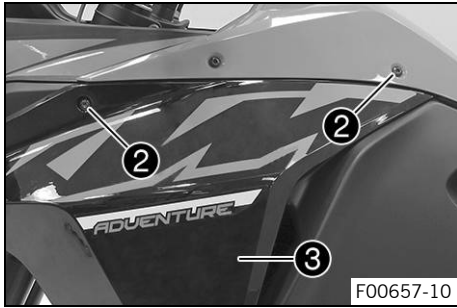

- Remove screws ②.
- Remove side cover ③.
- Repeat the operation on the opposite side.

## 13.19 Installing the front side cover

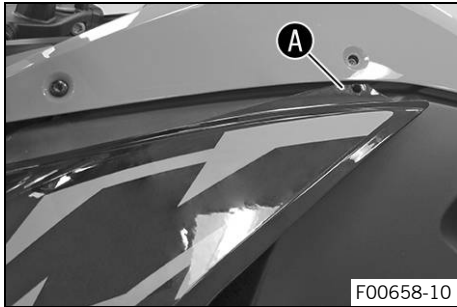

- Position the side cover in the area ① under the tank cover.

# 13 SERVICE WORK ON THE CHASSIS

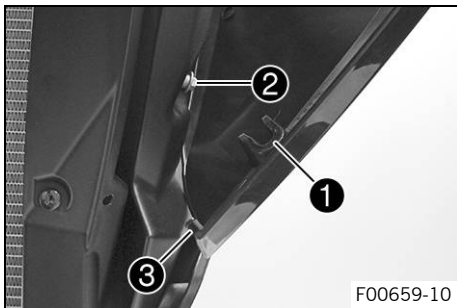

- Attach catch **1** of the side cover to bracket **2** and position on the fuel tank.
- Position the holding lug **3** in the drill hole.

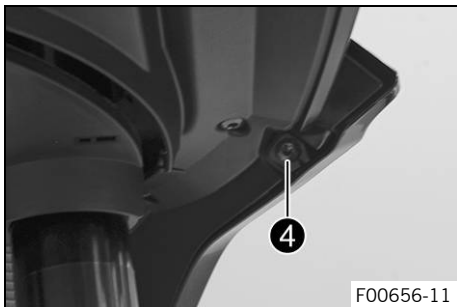

- Mount and tighten screw **4**.

Guideline

Screw, cover part	M5	3.5 Nm (2.58 lbf ft)
-------------------	----	-------------------------

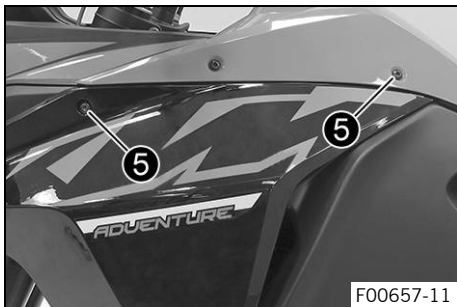

- Mount and tighten screws **5**.

Guideline

Screw, cover part	M5	3.5 Nm (2.58 lbf ft)
-------------------	----	-------------------------

- Repeat these steps on the opposite side.

## 13.20 Removing the mask spoiler ↴

### Preparatory work

- Remove the seat. (📖 p. 101)
- Remove the front side cover. (📖 p. 113)
- Remove the tank cover. (📖 p. 123)

### Main work

- Remove screw ①.



- Remove screw ②.

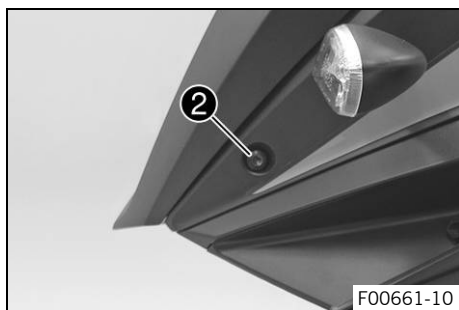

# 13 SERVICE WORK ON THE CHASSIS

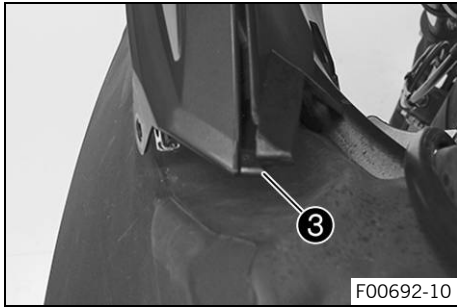

- Loosen holding lug 3 from the inside cover.

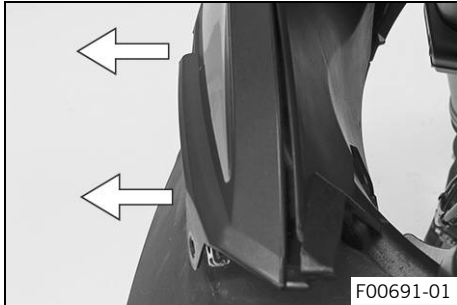

- Remove the mask spoiler laterally from the supports.

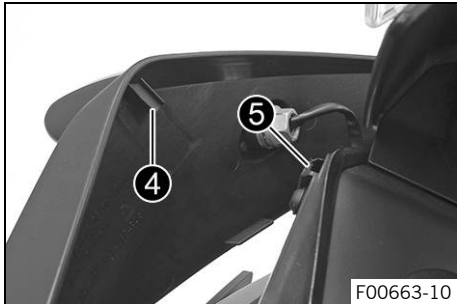

- Remove catch 4 upward from the bracket 5.



**Info**

Pay attention to the turn signal cable.

# 13 SERVICE WORK ON THE CHASSIS

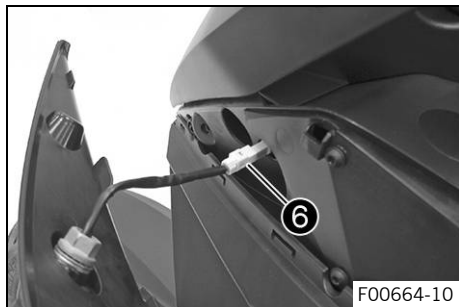

- Disconnect plug-in connector ⑥.
- Remove the mask spoiler with the turn signal.
- Repeat the operation on the opposite side.

## 13.21 Installing the mask spoiler ↗

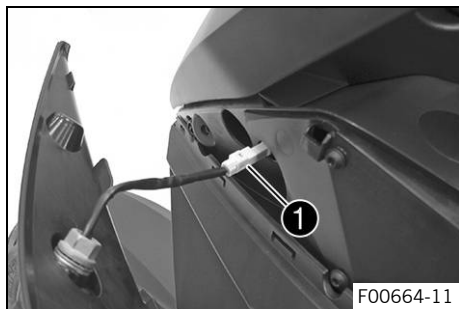

### Main work

- Connect plug-in connector ①.



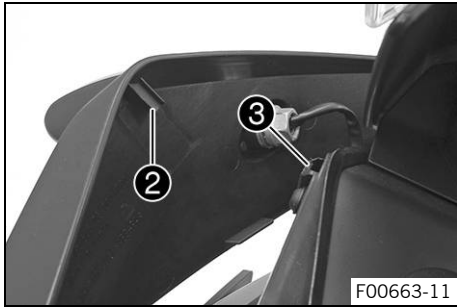

- Position the catch ② in the bracket ③.



**Info**

Ensure that the turn signal cable is placed correctly.

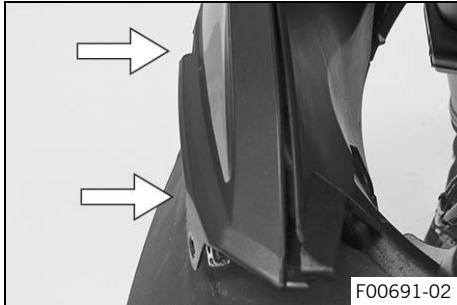

- Press the mask spoiler laterally into the supports.

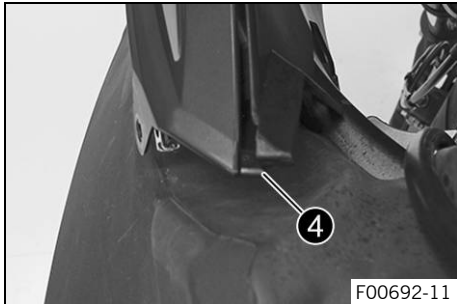

- Position the holding lug ④ in the drill hole.

# 13 SERVICE WORK ON THE CHASSIS

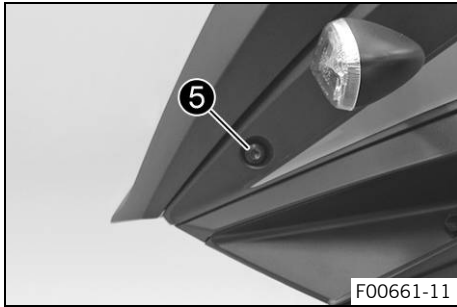

- Mount and tighten screw ⑤.

Guideline

Screw, mask spoiler	M5x17	3.5 Nm (2.58 lbf ft)
---------------------	-------	-------------------------

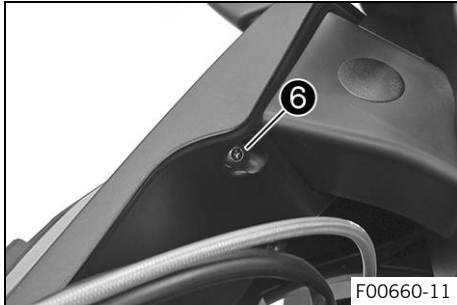

- Mount and tighten screw ⑥.

Guideline

Screw, mask spoiler	M5x17	3.5 Nm (2.58 lbf ft)
---------------------	-------	-------------------------

- Repeat the operation on the opposite side.

### Finishing work

- Install the tank cover. (📖 p. 125)
- Install the front side cover. (📖 p. 114)
- Mount the seat. (📖 p. 101)

## 13.22 Removing the front fender

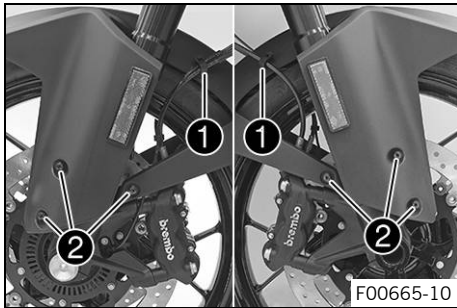

F00665-10

- Open holder **1** and detach the brake lines and cable.
- Remove screws **2**.
- Remove the fender in a forward direction.



### Info

Pay attention to the brake lines and the cable.

## 13.23 Installing the front fender

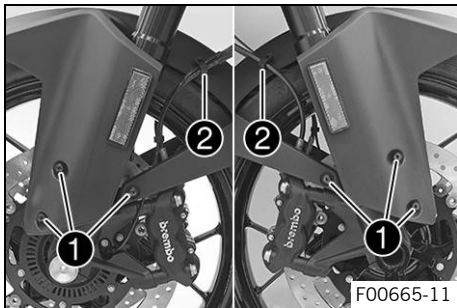

F00665-11

- Position the fender.



### Info

Pay attention to the routing of the brake lines and the cable.

- Mount and tighten screws **1**.

### Guideline

Screw, fender	M5x12	3.5 Nm (2.58 lbf ft)
---------------	-------	-------------------------

- Insert the brake lines and cable in brackets **2** and close the holder.

## 13.24 Cleaning the dust boots of the fork legs ↩



### Preparatory work

- Remove the front fender. (📖 p. 121)

### Main work

- Push dust boot ❶ of both fork legs downwards.

### Info

The dust boots should remove dust and coarse dirt particles from the fork tubes. Over time, dirt can penetrate behind the dust boots. If this dirt is not removed, the oil seals behind can start to leak.

### Warning

**Danger of accidents** Oil or grease on the brake discs reduces the braking effect.

- Always keep the brake discs free of oil and grease.
  - Clean the brake discs with brake cleaner when necessary.
- 
- Clean and oil the dust boots and inner fork tube of both fork legs.

Universal oil spray (📖 p. 220)

- Press the dust boots back into their normal position.
- Remove excess oil.

### Finishing work

- Install the front fender. (📖 p. 121)

## 13.25 Removing the tank cover

### Preparatory work

- Remove the seat. (📖 p. 101)
- Remove the front side cover. (📖 p. 113)

### Main work

- Remove screw ①.
- Remove screw ②.

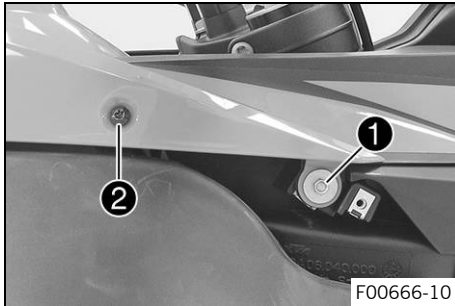

- Remove screw ③.
- Remove screw ④.

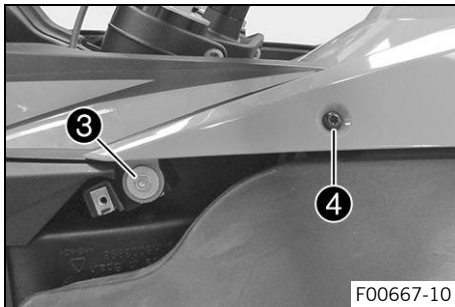

# 13 SERVICE WORK ON THE CHASSIS

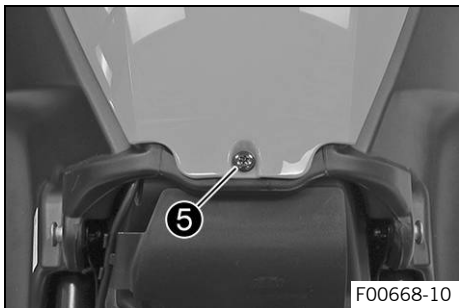

- Remove screw ⑤.



- Raise the tank cover at the rear and remove it in a forward direction.

## 13.26 Installing the tank cover

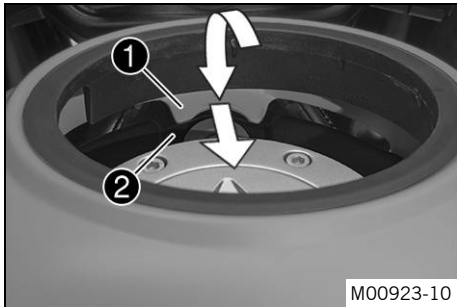

### Main work

- Position the tank cover.
  - ✓ The catch ① engages under the tank ②.

### Info

Pay attention to the sealing lip and the bleeder hose.

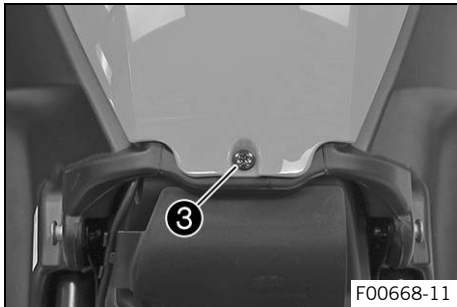

- Mount and tighten screw ③.

### Guideline

Screw, cover part	M5	3.5 Nm (2.58 lbf ft)
-------------------	----	-------------------------

# 13 SERVICE WORK ON THE CHASSIS

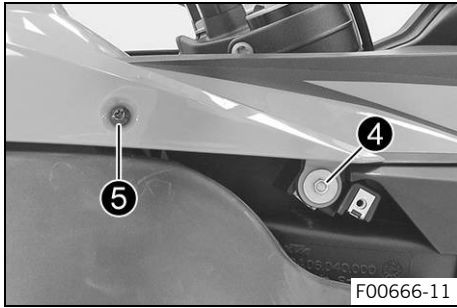

- Mount and tighten screw ④.

Guideline

Screw, cover part	M6	6 Nm (4.4 lbf ft)
-------------------	----	-------------------

- Mount and tighten screw ⑤.

Guideline

Screw, cover part	M5	3.5 Nm (2.58 lbf ft)
-------------------	----	-------------------------

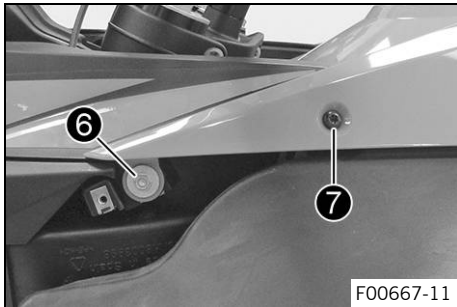

- Mount and tighten screw ⑥.

Guideline

Screw, cover part	M6	6 Nm (4.4 lbf ft)
-------------------	----	-------------------

- Mount and tighten screw ⑦.

Guideline

Screw, cover part	M5	3.5 Nm (2.58 lbf ft)
-------------------	----	-------------------------

### Finishing work

- Install the front side cover. (📖 p. 114)
- Mount the seat. (📖 p. 101)



## 13.27 Removing the wind shield

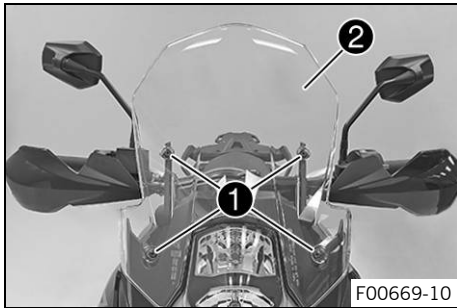

- Remove screws ❶ and wind shield ❷.

## 13.28 Installing the wind shield

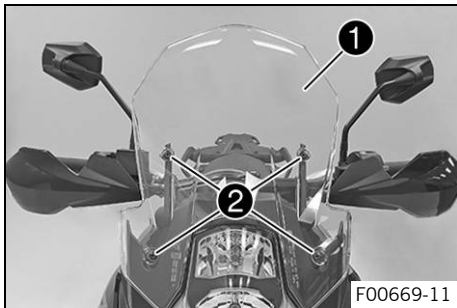

- Position wind shield ❶.
- Mount and tighten screws ❷.

Guideline

Screw, wind shield	M5	3.5 Nm (2.58 lbf ft)
--------------------	----	-------------------------

## 13.29 Removing the engine guard

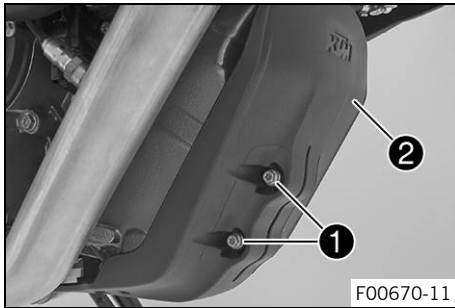

- Remove screws ① with bushings and engine guard ②.

## 13.30 Installing the engine guard

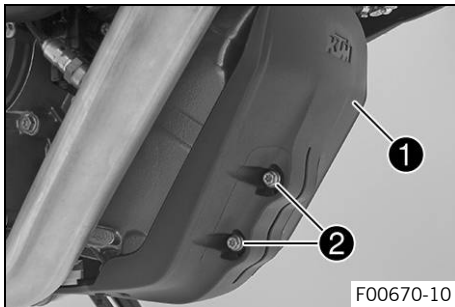

- Position engine guard ①, mount screws ② with bushings and tighten.

Guideline

Screw, engine guard	M6	10 Nm (7.4 lbf ft)
---------------------	----	--------------------

## 14.1 ABS / anti-blocking system

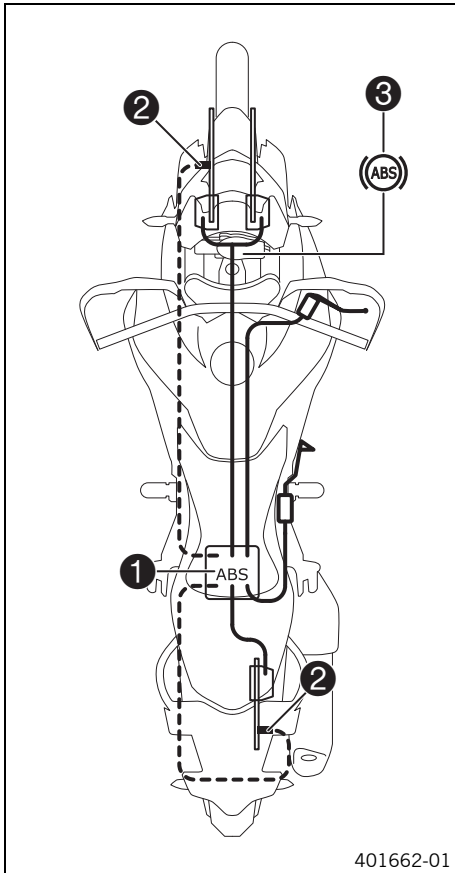

The ABS unit **1**, which consists of a hydraulic unit, brake electronics control unit, and return pump, is installed under the seat. One wheel speed sensor **2** is located in each case on the front and the rear wheel.



### Warning

**Danger of accidents** Changes to the vehicle impair the function of the ABS.

- Only allow the rear wheel to spin with the front brake applied away from public road traffic if the ABS is switched off.
- Do not make any changes to the suspension travel.
- Only use spare parts on the brake system which have been approved and recommended by KTM.
- Only use tires/wheels approved by KTM with the corresponding speed index.
- Maintain the specified tire air pressure.
- Service work and repairs must be performed professionally. (Your authorized KTM workshop will be glad to help.)



### Warning

**Voiding of the government approval for road use and the insurance coverage** If the ABS is switched off completely, the vehicle's approval for road use is invalidated.

- Only operate the vehicle in closed-off areas remote from public road traffic if the ABS is switched off completely.

ABS is a safety system that prevents locking of the wheels when driving straight ahead without the influence of lateral forces.



## Warning

**Danger of accidents** Driving aids can only prevent a rollover within the physical limitations.

It is not always possible to compensate for extreme riding situations, for example with luggage loaded with a high center of gravity, varying road surfaces, steep descents or full braking without disengaging the gear.

- Adapt your riding style to the road conditions and your driving ability.

---

The ABS operates with two independent brake circuits (front and rear brakes). When the brake electronics control unit detects a locking tendency in a wheel, ABS begins regulating the brake pressure. The regulating process causes a slight pulsing of the hand and foot brake levers.

The ABS bulb **3** must light up after the ignition is switched on and go out after starting off. If it does not go out after starting off or if it is lit while riding, this indicates a fault in the ABS system. In this case, the ABS is no longer enabled and the wheels may lock during braking. The brake system itself stays functional; only ABS control is not available.

The ABS lamp may also light up if the rotating speeds of the front and rear wheels differ greatly under extreme riding conditions, for example when making "wheelies" or if the rear wheel spins. This causes the ABS to switch off.

To reactivate the ABS, stop the vehicle and switch off the ignition. The ABS is reactivated when the vehicle is switched on again. The ABS lamp goes out when you start off.

In the **"MTC/ABS"** menu, ABS can be switched off manually.



## Info

After the ignition is switched back on, ABS is reactivated.

---

## 14.2 Checking the brake discs



### Warning

**Danger of accidents** Worn-out brake discs reduce the braking effect.

- Make sure that worn-out brake discs are replaced immediately. (Your authorized KTM workshop will be glad to help.)

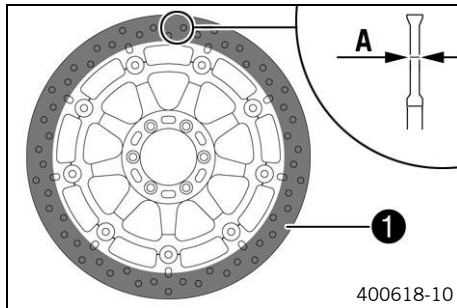

- Check the thickness of the front and rear brake discs at multiple points on each brake disc to ensure it is at least thickness **A**.

### **i** Info

Wear will reduce the thickness of the brake disc at the contact surface **1** of the brake linings.

Brake discs - wear limit	
Front	4 mm (0.16 in)
Rear	4.5 mm (0.177 in)

- » If the brake disc thickness is less than the specified value.
  - Change the front brake discs. 🛠️
  - Change the rear brake discs. 🛠️
- Check the front and rear brake discs for damage, cracking, and deformation.
  - » If the brake disc exhibits damage, cracking, or deformation:
    - Change the front brake discs. 🛠️
    - Change the rear brake discs. 🛠️

## 14.3 Checking the brake fluid level of the front brake



### Warning

**Danger of accidents** An insufficient brake fluid level will cause the brake system to fail.

If the brake fluid level drops below the **MIN** marking, the brake system is leaking or the brake linings are worn down.

- Check the brake system and do not continue riding until the problem is eliminated. (Your authorized KTM workshop will be glad to help.)



### Warning

**Danger of accidents** Old brake fluid reduces the braking effect.

- Make sure that brake fluid for the front and rear brake is changed in accordance with the service schedule. (Your authorized KTM workshop will be glad to help.)

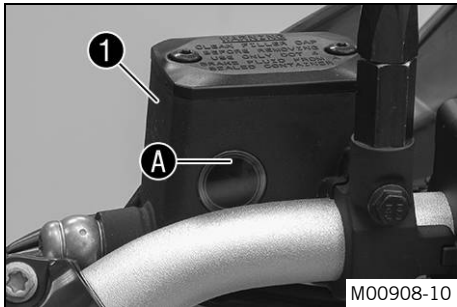

- Move the brake fluid reservoir mounted on the handlebar to a horizontal position.
- Check the brake fluid level in the brake fluid reservoir **1**.
  - » If the brake fluid has dropped below marking **MIN A**:
    - Add front brake fluid. 🛠️ (📖 p. 133)

## 14.4 Adding front brake fluid



### Warning

**Danger of accidents** An insufficient brake fluid level will cause the brake system to fail.

If the brake fluid level drops below the **MIN** marking, the brake system is leaking or the brake linings are worn down.

- Check the brake system and do not continue riding until the problem is eliminated. (Your authorized KTM workshop will be glad to help.)



### Warning

**Skin irritation** Brake fluid causes skin irritation.

- Keep brake fluid out of the reach of children.
- Wear suitable protective clothing and safety glasses.
- Do not allow brake fluid to come into contact with the skin, the eyes or clothing.
- Consult a doctor immediately if brake fluid has been swallowed.
- Rinse the affected area with plenty of water in the event of contact with the skin.
- Rinse eyes thoroughly with water immediately and consult a doctor if brake fluid comes into contact with the eyes.
- If brake fluid spills on to your clothing, change the clothing.



### Warning

**Danger of accidents** Old brake fluid reduces the braking effect.

- Make sure that brake fluid for the front and rear brake is changed in accordance with the service schedule. (Your authorized KTM workshop will be glad to help.)



### Warning

**Environmental hazard** Hazardous substances cause environmental damage.

- Dispose of oils, grease, filters, fuel, cleaning agents, brake fluid, etc., correctly and in compliance with the applicable regulations.

## **i** Info

Never use DOT 5 brake fluid! It is silicone-based and purple in color. Oil seals and brake lines are not designed for DOT 5 brake fluid.  
Avoid contact between brake fluid and painted parts. Brake fluid attacks paint!  
Use only clean brake fluid from a sealed container.

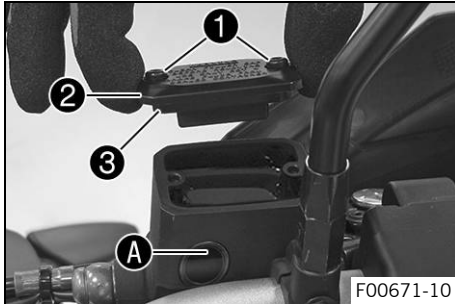

## Preparatory work

- Check the front brake linings. (📖 p. 134)

## Main work

- Move the brake fluid reservoir mounted on the handlebar to a horizontal position.
- Remove screws ①.
- Remove cover ② with membrane ③.
- Add brake fluid to the **MAX** mark **A**.

Brake fluid DOT 4 / DOT 5.1 (📖 p. 216)

- Position cover ② with membrane ③.
- Mount and tighten screws ①.

## **i** Info

Clean up overflowed or spilled brake fluid immediately with water.

## 14.5 Checking the front brake linings

### **!** Warning

**Danger of accidents** Worn-out brake linings reduce the braking effect.

- Ensure that worn-out brake linings are replaced immediately. (Your authorized KTM workshop will be glad to help.)





## Warning

**Danger of accidents** Damaged brake discs reduce the braking effect.

If the brake linings are not changed in time, the brake lining carriers grind against the brake disc. As a consequence, the braking effect is greatly reduced and the brake discs are destroyed.

- Check the brake linings regularly.

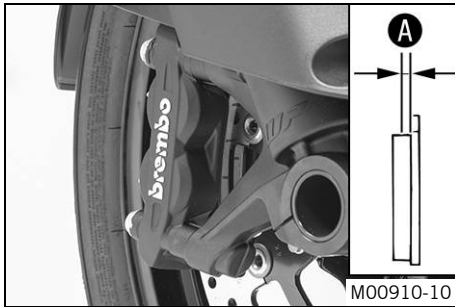

- Check all brake linings on both brake calipers to ensure they have minimum thickness **A**.

Minimum thickness	$\geq 1 \text{ mm } (\geq 0.04 \text{ in})$
-------------------	---

- » If the minimum thickness is less than specified:
  - Change the front brake linings. 🛠️
- Check all brake linings on both brake calipers for damage and cracking.
  - » If there is damage or cracking:
    - Change the front brake linings. 🛠️

## 14.6 Checking the rear brake fluid level



## Warning

**Danger of accidents** An insufficient brake fluid level will cause the brake system to fail.

If the brake fluid level drops below the **MIN** marking, the brake system is leaking or the brake linings are worn down.

- Check the brake system and do not continue riding until the problem is eliminated. (Your authorized KTM workshop will be glad to help.)



## Warning

**Danger of accidents** Old brake fluid reduces the braking effect.

- Make sure that brake fluid for the front and rear brake is changed in accordance with the service schedule. (Your authorized KTM workshop will be glad to help.)

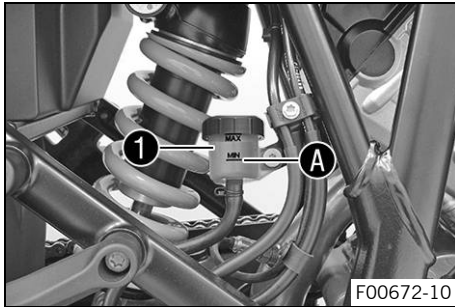

- Check the brake fluid level in the brake fluid reservoir **1**.
  - » If the fluid level reaches the **MIN** marking **A**:
    - Add rear brake fluid. 🛠️ (📖 p. 136)

## 14.7 Adding rear brake fluid 🛠️



## Warning

**Danger of accidents** An insufficient brake fluid level will cause the brake system to fail.

If the brake fluid level drops below the **MIN** marking, the brake system is leaking or the brake linings are worn down.

- Check the brake system and do not continue riding until the problem is eliminated. (Your authorized KTM workshop will be glad to help.)



## Warning

**Skin irritation** Brake fluid causes skin irritation.

- Keep brake fluid out of the reach of children.
- Wear suitable protective clothing and safety glasses.
- Do not allow brake fluid to come into contact with the skin, the eyes or clothing.
- Consult a doctor immediately if brake fluid has been swallowed.
- Rinse the affected area with plenty of water in the event of contact with the skin.
- Rinse eyes thoroughly with water immediately and consult a doctor if brake fluid comes into contact with the eyes.
- If brake fluid spills on to your clothing, change the clothing.



## Warning

**Danger of accidents** Old brake fluid reduces the braking effect.

- Make sure that brake fluid for the front and rear brake is changed in accordance with the service schedule. (Your authorized KTM workshop will be glad to help.)



## Warning

**Environmental hazard** Hazardous substances cause environmental damage.

- Dispose of oils, grease, filters, fuel, cleaning agents, brake fluid, etc., correctly and in compliance with the applicable regulations.



## Info

Never use DOT 5 brake fluid! It is silicone-based and purple in color. Oil seals and brake lines are not designed for DOT 5 brake fluid.

Avoid contact between brake fluid and painted parts. Brake fluid attacks paint!

Use only clean brake fluid from a sealed container.

---

## Preparatory work

- Check the rear brake linings. (📖 p. 138)

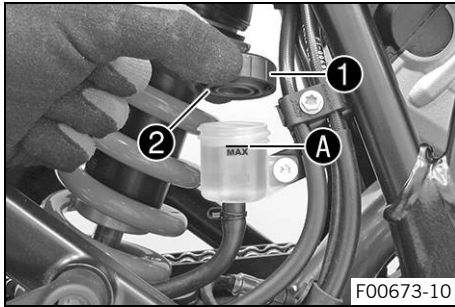

## Main work

- Remove screw cap ① with membrane ②.
- Add brake fluid to the **MAX** mark A.

Brake fluid DOT 4 / DOT 5.1 (📖 p. 216)

- Mount and tighten screw cap ① with membrane ②.



## Info

Clean up overflowed or spilt brake fluid immediately with water.

## 14.8 Checking the rear brake linings



### Warning

**Danger of accidents** Worn-out brake linings reduce the braking effect.

- Ensure that worn-out brake linings are replaced immediately. (Your authorized KTM workshop will be glad to help.)



### Warning

**Danger of accidents** Damaged brake discs reduce the braking effect.

If the brake linings are not changed in time, the brake lining carriers grind against the brake disc. As a consequence, the braking effect is greatly reduced and the brake discs are destroyed.

- Check the brake linings regularly.

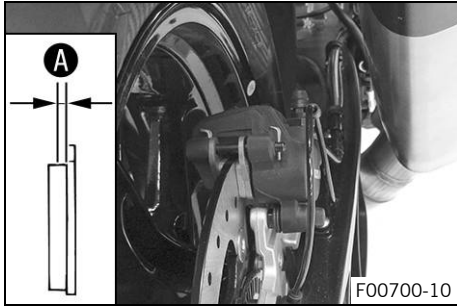

- Check the brake linings for minimum thickness **A**.

Minimum thickness <b>A</b>	$\geq 1 \text{ mm } (\geq 0.04 \text{ in})$
----------------------------	---

- » If the minimum thickness is less than specified:
  - Change the rear brake linings. 🛠️
- Check the brake linings for damage and cracking.
  - » If there is wear or tearing:
    - Change the rear brake linings. 🛠️

## 15.1 Removing the front wheel 🛠️

### Preparatory work

- Raise the motorcycle with the rear lifting gear. (📖 p. 96)
- Remove the bottom triple clamp cover. (📖 p. 111)
- Lift the motorcycle with the front lifting gear. (📖 p. 97)

### Main work

- Remove screw ❶ and pull wheel speed sensor ❷ out of the hole.

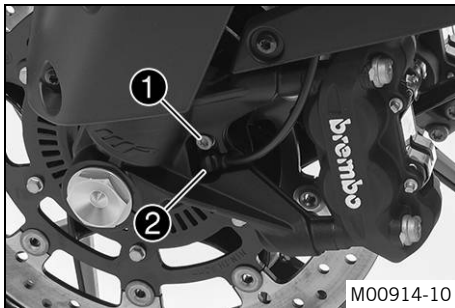

- Remove screws ❸ from both brake calipers.
- Press back the brake linings with a slight lateral tilting of the brake calipers on the brake disc.
- Pull the brake calipers carefully back from the brake discs and hang them to one side loosely.



### Info

Do not pull the hand brake lever when the brake caliper has been removed.

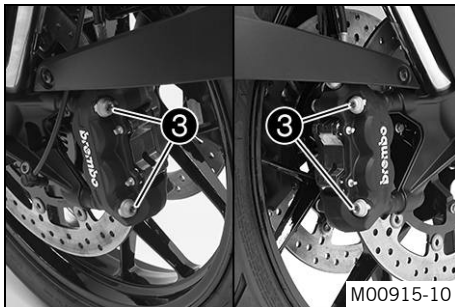

# 15 WHEELS, TIRES

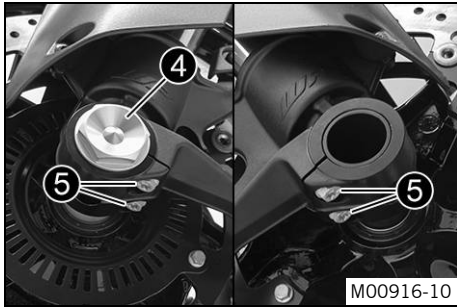

- Loosen screw ④ by several rotations.
- Release screws ⑤.
- Press on screw ④ to push the wheel spindle out the axle clamp.
- Remove screw ④.



### Warning

**Danger of accidents** Damaged brake discs reduce the braking effect.

- Always lay the wheel down in such a way that the brake discs are not damaged.

- Hold the front wheel and remove the wheel spindle. Take the front wheel out of the fork.



### Info

Do not pull the hand brake lever when the front wheel is removed.

- Remove spacers ⑥.

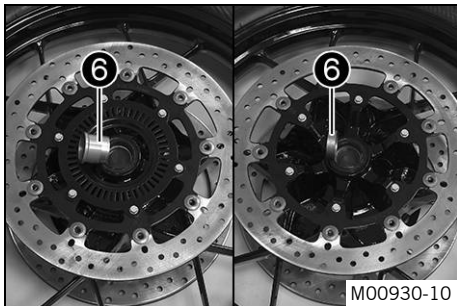

## 15.2 Installing the front wheel ↩



### Warning

**Danger of accidents** Oil or grease on the brake discs reduces the braking effect.

- Always keep the brake discs free of oil and grease.
- Clean the brake discs with brake cleaner when necessary.

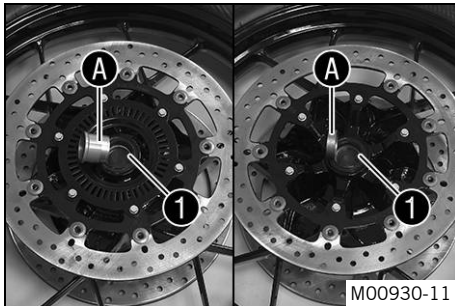

- Check the wheel bearing for damage and wear.
  - » If the wheel bearing is damaged or worn:
    - Change the front wheel bearing. ↩
- Clean and grease shaft seal rings **1** and mating surfaces **A** of the spacers.

Long-life grease (📖 p. 219)

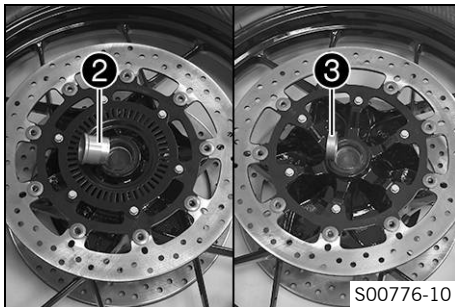

- Insert wide spacer **2** on the left in the direction of travel.



### Info

The ABS sensor wheel is on the left viewed in the direction of travel.

- Insert the narrow spacer **3** on the right in the direction of travel.



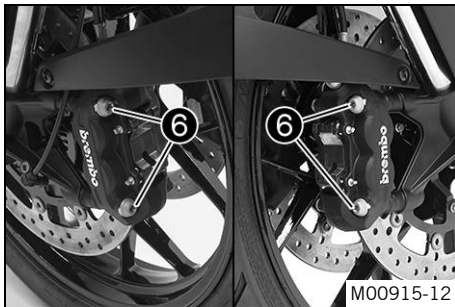
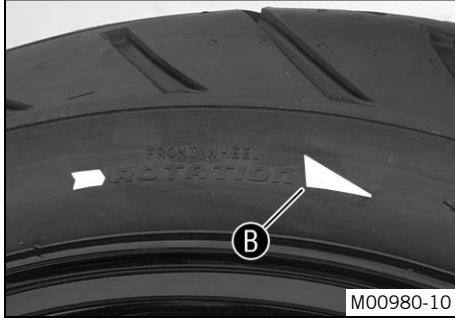
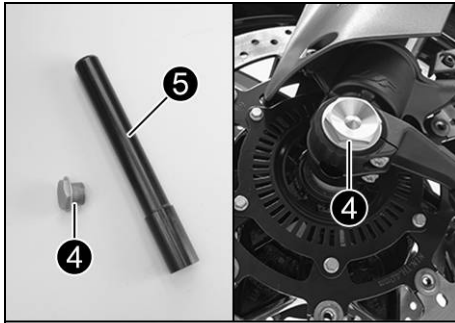

### Warning

**Danger of accidents** Oil or grease on the brake discs reduces the braking effect.

- Always keep the brake discs free of oil and grease.
- Clean the brake discs with brake cleaner when necessary.

- Clean and grease screw **4** and wheel spindle **5**.

Long-life grease (📖 p. 219)

- Lift the front wheel into the fork, position it, and insert the wheel spindle.



### Info

The ABS sensor wheel is located on the left in the direction of travel.

Arrow **B** must point in the direction of travel.

The position of the direction of travel indicator on the tires can vary.

- Mount and tighten screw **4**.

### Guideline

Screw, front wheel spindle	M25x1.5	45 Nm (33.2 lbf ft)	Thread greased
----------------------------	---------	------------------------	----------------

- Position the brake calipers.
  - ✓ The brake linings are correctly positioned.
- Mount screws **6** on both brake calipers but do not tighten yet.
- Operate the hand brake lever repeatedly until the brake linings are in contact with the brake disc and there is a pressure point. Fix the hand brake lever in the activated position.
  - ✓ The brake calipers straighten.
- Tighten screws **6** on both brake calipers.

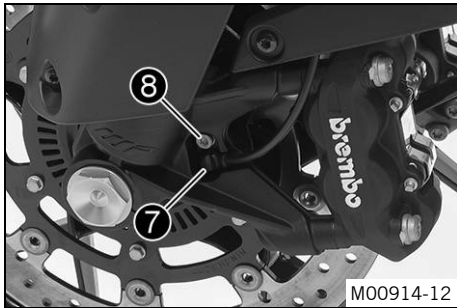

Guideline

Screw, front brake caliper	M10	45 Nm (33.2 lbf ft)	Loctite® 243™
----------------------------	-----	------------------------	---------------

- Remove the locking piece of the hand brake lever.
- Position wheel speed sensor 7 in the drill hole.
- Mount and tighten screw 8.

Guideline

Screw, wheel speed sensor, front	M6	10 Nm (7.4 lbf ft)
----------------------------------	----	--------------------

- Take the motorcycle from the front lifting gear. (📖 p. 98)
- Remove the rear of the motorcycle from the lifting gear. (📖 p. 96)

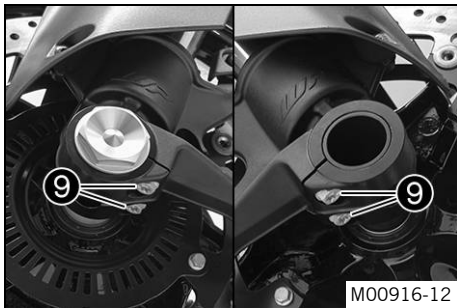

- Operate the front brake and compress the fork a few times firmly.  
✓ The fork legs straighten.
- Tighten screws 9.

Guideline

Screw, fork stub	M8	15 Nm (11.1 lbf ft)
------------------	----	------------------------

## 15.3 Removing the rear wheel ↩

### Preparatory work

- Raise the motorcycle with the rear lifting gear. (📖 p. 96)

### Main work

- Press the brake caliper onto the brake disc by hand in order to push back the brake pistons.

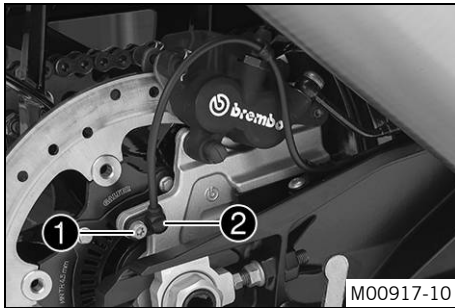
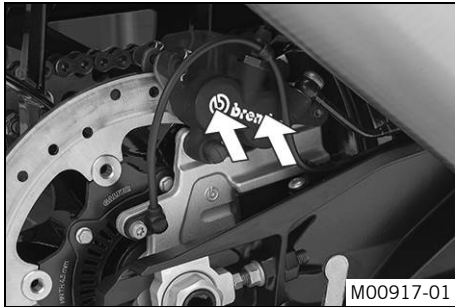

- Remove screw ❶ and pull wheel speed sensor ❷ out of the hole.

# 15 WHEELS, TIRES

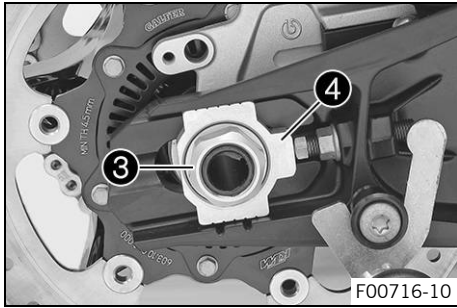

- Remove nut ③. Remove chain adjuster ④.

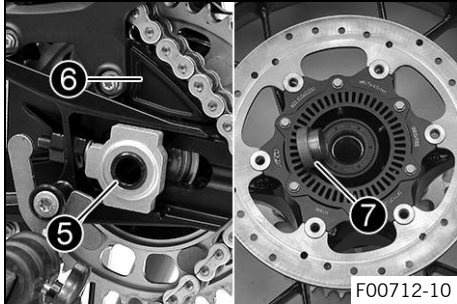

- Withdraw wheel spindle ⑤ only enough to allow the rear wheel to be pushed forward.
- Push the rear wheel forward as far as possible. Take the chain off of the rear sprocket and place it on chain sprocket guard ⑥.



### Warning

**Danger of accidents** Reduced braking effect caused by damaged brake discs.

- Always lay the wheel down in such a way that the brake discs are not damaged.

- Holding the rear wheel, withdraw the wheel spindle. Take the rear wheel out of the swingarm.



### Info

Do not operate the foot brake when the rear wheel is removed.

- Remove spacer ⑦.

## 15.4 Installing the rear wheel 🛠️



### Warning

**Danger of accidents** Oil or grease on the brake discs reduces the braking effect.

- Always keep the brake discs free of oil and grease.
- Clean the brake discs with brake cleaner when necessary.



### Warning

**Danger of accidents** There is no braking effect to start with at the rear brake after installing the rear wheel.

- Actuate the foot brake several times before going on a ride until you can feel a firm pressure point.

### Main work

- Check the rear hub rubber dampers. 🛠️ (📖 p. 149)
- Check the wheel bearing for damage and wear.
  - » If the wheel bearing is damaged or worn:
    - Change the rear wheel bearing. 🛠️
- Clean and grease shaft seal ring ① and contact surface A of the spacer.

Long-life grease (📖 p. 219)

- Clean and grease the thread of the wheel spindle and nut.

Long-life grease (📖 p. 219)

- Install the rubber dampers and rear sprocket carrier on the rear wheel.
- Place the rear wheel in the swingarm and bring the brake disc into contact with the brake caliper.

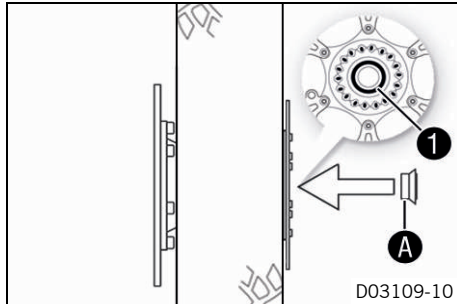

# 15 WHEELS, TIRES



- Mount wheel spindle ② but do not push it in all the way.
- Push the rear wheel as far forward as possible and place the chain on the rear sprocket.

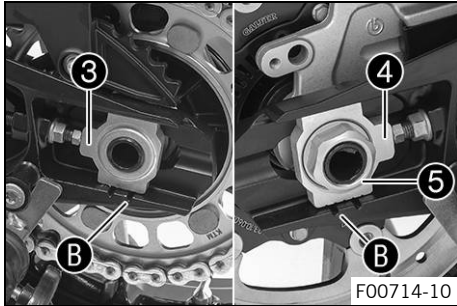

- Push the wheel spindle in all the way and mount chain adjuster ④ and nut ⑤.



### Info

Mount chain adjusters ③ and ④ in the same position.

- Make sure that the chain adjusters are fitted correctly on the adjusting screws.

### Guideline

In order for the rear wheel to be correctly aligned, the markings on the left and right chain adjusters must be in the same position relative to reference markings **B**.

- Tighten nut ⑤.

### Guideline

Nut, rear wheel spindle	M25x1.5	90 Nm (66.4 lbf ft)	Thread greased
-------------------------	---------	------------------------	----------------

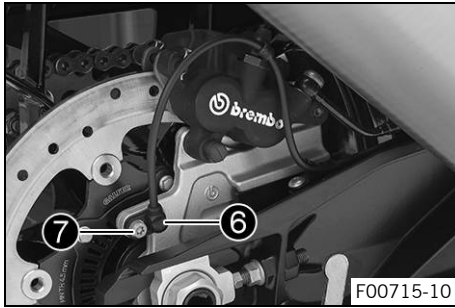

- Position wheel speed sensor **6** in the drill hole.
- Mount and tighten screw **7**.

#### Guideline

Screw, wheel speed sensor, rear	M6	10 Nm (7.4 lbf ft)
---------------------------------	----	--------------------

- Operate the foot brake lever repeatedly until the brake linings are in contact with the brake disc and there is a pressure point.

#### Finishing work

- Remove the rear of the motorcycle from the lifting gear. (📖 p. 96)

## 15.5 Checking the rear hub rubber dampers 🛠️



#### Info

The engine power is transmitted from the rear sprocket to the rear wheel via 6 rubber dampers. The rubber dampers wear out during operation. If the rubber dampers are not changed in time, the rear sprocket carrier and the rear hub will be damaged.

#### Preparatory work

- Raise the motorcycle with the rear lifting gear. (📖 p. 96)
- Remove the rear wheel. 🛠️ (📖 p. 145)

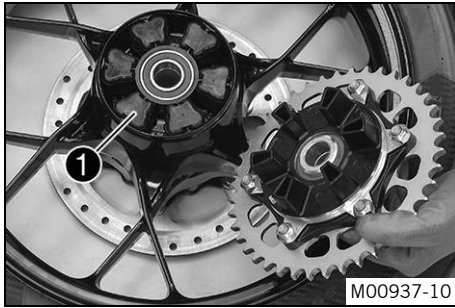

## Main work

- Check the rubber dampers ① of the rear hub for damage and wear.
  - » If the rubber dampers of the rear hub are damaged or worn:
    - Change all rubber dampers in the rear hub. 🛠️

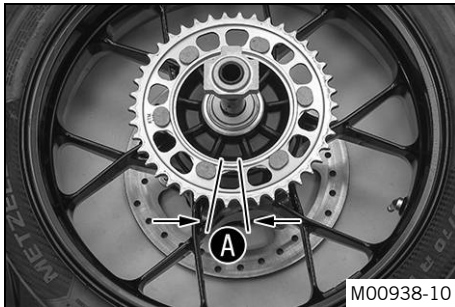

- Lay the rear wheel on a workbench with the rear sprocket facing upwards and insert the wheel spindle in the hub.
- Check the rear sprocket play ①.

## Info

Measure the play on the outside of the rear sprocket.

Play in rubber dampers, rear wheel	≤ 5 mm (≤ 0.2 in)
------------------------------------	-------------------

- » If clearance ① larger than the specified value:
  - Change all rubber dampers in the rear hub. 🛠️

## Finishing work

- Install the rear wheel. 🛠️ (📖 p. 147)
- Remove the rear of the motorcycle from the lifting gear. (📖 p. 96)





## 15.6 Checking the tire condition

-  **Warning**  
**Danger of accidents** If a tire bursts while riding, the vehicle becomes uncontrollable.
- Ensure that damaged or worn tires are replaced immediately. (Your authorized KTM workshop will be glad to help.)

-  **Warning**  
**Danger of crashing** Different tire tread patterns on the front and rear wheel impair the handling characteristic. Different tire tread patterns can make the vehicle significantly more difficult to control.
- Make sure that only tires with a similar tire tread pattern are fitted to the front and rear wheel.

-  **Warning**  
**Danger of accidents** Non-approved or non-recommended tires and wheels impact the handling characteristic.
- Only use tires/wheels approved by KTM with the corresponding speed index.

-  **Warning**  
**Danger of accidents** New tires have reduced road grip. The contact surface on new tires is not yet roughened.
- Run in new tires with moderate riding at alternating angles.  
Running-in phase 200 km (124 mi)

-  **Info**  
Tire type, tire condition, and tire air pressure influence the braking and handling characteristics of the vehicle. Worn tires are particularly unfavorable on wet surfaces.

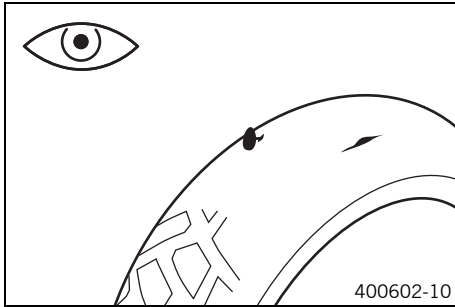

- Check the front and rear tires for cuts, run-in objects, and other damage.
  - » If the tires have cuts, run-in objects, or other damage:
    - Change the tires.
- Check the tread depth.



### Info

Adhere to the legally required minimum tread depth.

Minimum tread depth	$\geq 2 \text{ mm } (\geq 0.08 \text{ in})$
---------------------	---

- » If the tread depth is less than the minimum tread depth:
  - Change the tires.
- Check the tire age.



### Info

The tire date of manufacture is usually contained in the tire label and is indicated by the last four digits of the **DOT** number. The first two digits indicate the week of manufacture and the last two digits the year of manufacture. KTM recommends that the tires be changed after 5 years at the latest, regardless of the actual state of wear.

- » If the tires are more than 5 years old:
  - Change the tires.

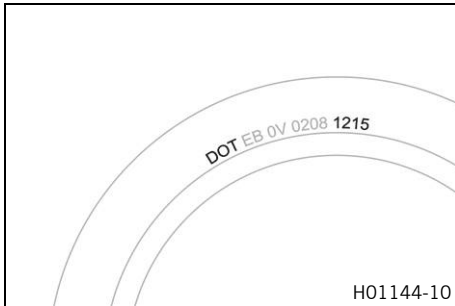

## 15.7 Checking the tire air pressure



### Info

Low tire air pressure leads to abnormal wear and overheating of the tire. Correct tire air pressure ensures optimal riding comfort and maximum tire service life.

# 15 WHEELS, TIRES

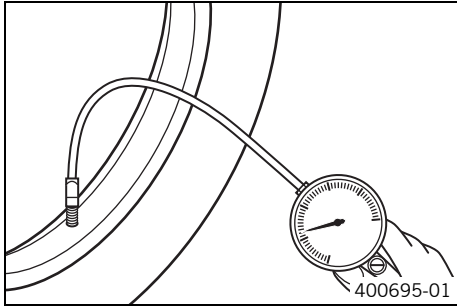

- Remove the dust cap.
- Check the tire air pressure when the tires are cold.

Tire air pressure, solo/with passenger/full payload	
Front: with cold tires	2.4 bar (35 psi)
Rear: with cold tires	2.9 bar (42 psi)

- » If the tire pressure does not meet specifications:
  - Correct the tire pressure.
- Mount the dust cap.

## 16.1 Daytime running light

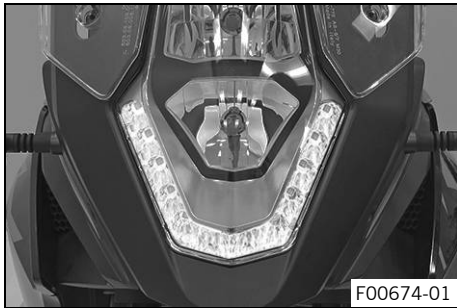

### Warning

**Danger of accidents** When visibility is poor, the daytime running light is not a substitute for the low beam.

Automatic switching between the daytime running light and low beam may only be partially available when visibility is significantly impaired due to fog, snow or rain.

- Ensure that the appropriate type of lighting is always selected.
- If necessary switch off the daytime running lights using the menu before going on a ride or when stopped so that the low beam is switched on permanently.
- Note the legal regulations regarding the daytime running light.

The daytime running light/parking light is integrated in the main headlight.

The daytime running light (DRL) can be switched on when visibility conditions are good. Activate the daytime running light in the combination instrument. Control is provided by the brightness sensor in the combination instrument. When visibility conditions are good, the low beam is switched off and the daytime running light is switched on. It is four times brighter than the parking light. When the daytime running light is switched off, it serves as a parking light.

## 16.2 Removing the battery ↴



### Warning

**Risk of injury** Battery acid and battery gases cause serious chemical burns.

- Keep batteries out of the reach of children.
- Wear suitable protective clothing and safety glasses.
- Avoid contact with battery acid and battery gases.
- Keep sparks or open flames away from the battery.
- Only charge batteries in well-ventilated rooms.
- Rinse the affected area immediately with plenty of water in the event of contact with the skin.
- Rinse eyes with water for at least 15 minutes and consult a doctor immediately if battery acid and battery gases get into the eyes.



### Caution

**Danger of accidents** Electronic components and safety devices will be damaged if the battery is discharged or missing.

- Never operate the vehicle with a discharged battery or without a battery.

---

### Preparatory work

- Switch off all power consumers and switch off the engine.
- Remove the seat. (📖 p. 101)

# 16 ELECTRICAL SYSTEM

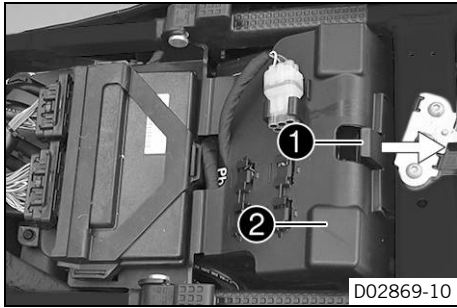

## Main work

- Pull locking mechanism ① in the direction of the arrow.
- Fold open cover ②.

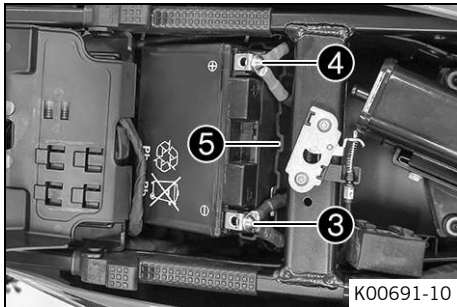

- Disconnect negative cable ③ from the battery.
- Disconnect positive cable ④ from the battery.
- Take the battery and battery case ⑤ out of the battery compartment.

## 16.3 Installing the battery ↱



### Warning

**Risk of injury** Battery acid and battery gases cause serious chemical burns.

- Keep batteries out of the reach of children.
- Wear suitable protective clothing and safety glasses.
- Avoid contact with battery acid and battery gases.
- Keep sparks or open flames away from the battery.
- Only charge batteries in well-ventilated rooms.
- Rinse the affected area immediately with plenty of water in the event of contact with the skin.
- Rinse eyes with water for at least 15 minutes and consult a doctor immediately if battery acid and battery gases get into the eyes.



### Caution

**Danger of accidents** Electronic components and safety devices will be damaged if the battery is discharged or missing.

- Never operate the vehicle with a discharged battery or without a battery.

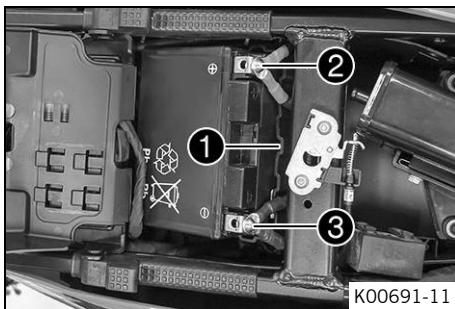

### Main work

- Position the battery in battery case ❶.

#### Guideline

The even side of the battery case must be opposite the poles.

- Position the battery and battery case in the battery compartment.
- Position the positive cable ❷ and mount and tighten the screw.

#### Guideline

Screw, battery terminal	M6	4.5 Nm (3.32 lbf ft)
-------------------------	----	-------------------------

- Position the negative cable ③ and mount and tighten the screw.

Guideline

Screw, battery terminal	M6	4.5 Nm (3.32 lbf ft)
-------------------------	----	-------------------------

- Close the cover ④ and push down slightly.  
✓ The cover engages with an audible click.

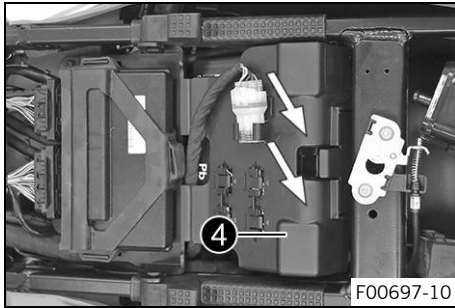

### Finishing work

- Mount the seat. (📖 p. 101)
- Set the time and date.



## 16.4 Recharging the battery ↴



### Warning

**Risk of injury** Battery acid and battery gases cause serious chemical burns.

- Keep batteries out of the reach of children.
- Wear suitable protective clothing and safety glasses.
- Avoid contact with battery acid and battery gases.
- Keep sparks or open flames away from the battery.
- Only charge batteries in well-ventilated rooms.
- Rinse the affected area immediately with plenty of water in the event of contact with the skin.
- Rinse eyes with water for at least 15 minutes and consult a doctor immediately if battery acid and battery gases get into the eyes.



### Warning

**Environmental hazard** Batteries contain environmentally-hazardous materials.

- Do not dispose of batteries as household waste.
- Dispose of batteries at a collection point for used batteries.



### Warning

**Environmental hazard** Hazardous substances cause environmental damage.

- Dispose of oils, grease, filters, fuel, cleaning agents, brake fluid, etc., correctly and in compliance with the applicable regulations.

## **i** Info

Even when there is no load on the battery, it discharges steadily.

The charge state and the type of charge are very important for the service life of the battery.

Rapid recharging with a high charging current shortens the battery's service life.

If the charging current, charging voltage, and charging time are exceeded, electrolyte escapes through the safety valves. This reduces the battery capacity.

If the battery is depleted from starting the vehicle repeatedly, the battery must be charged immediately.

If the battery is left in a discharged state for an extended period, it will become over-discharged and sulfate, destroying the battery.

The battery is maintenance-free, i.e., the acid level does not have to be checked.

If the battery is not charged using the KTM battery charger, the battery must be removed for charging. Otherwise, overvoltage may damage electronic components. Charge the battery according to the instructions on the battery housing.

### Preparatory work

- Switch off all power consumers and switch off the engine.
- Remove the seat. (📖 p. 101)

### Main work

- Pull locking mechanism **1** in the direction of the arrow.
- Fold open cover **2**.

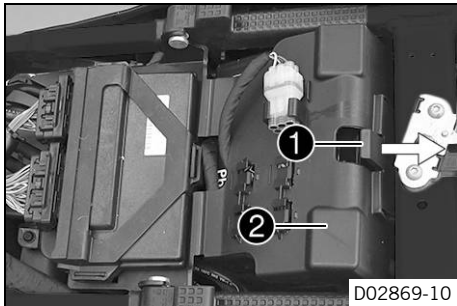

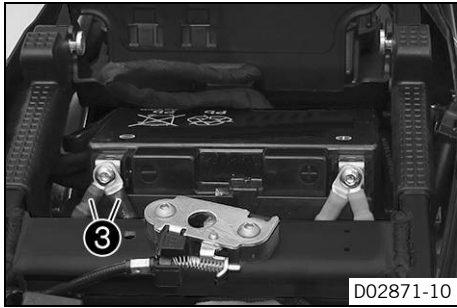

- Disconnect negative cable ③ of the battery to avoid damage to the motorcycle's electronics.



- Connect the battery charger to the battery. Switch on the battery charger.

Battery charger (58429074000)



**Info**

You can also use the battery charger to test the open-circuit voltage and start potential of the battery, and to test the alternator. With this device, you cannot overcharge the battery.

Charge the battery with a maximum of 10% of the capacity specified on the battery housing.

- Switch off the battery charger after charging and disconnect from the battery.

**Guideline**

The charging current, charging voltage, and charging time must not be exceeded.	
Charge the battery regularly when the motorcycle is not in use	3 months

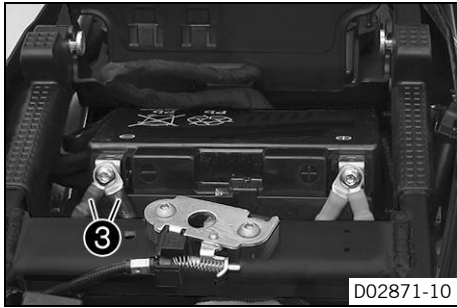

- Connect both negative cables ③ with the battery.

Guideline

Screw, battery terminal	M6	4.5 Nm (3.32 lbf ft)
-------------------------	----	-------------------------

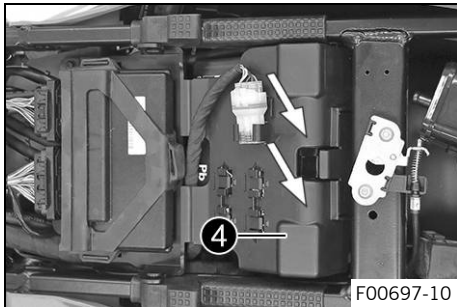

- Close cover ④ and push down slightly.  
✓ The cover engages with an audible click.

### Finishing work

- Mount the seat. (📖 p. 101)
- Set the time and date.

## 16.5 Changing the main fuse



### Warning

**Fire hazard** Incorrect fuses overload the electrical system.

- Only use fuses with the required ampere value.
- Do not bypass or repair fuses.

### Preparatory work

- Switch off all power consumers and switch off the engine.
- Remove the seat. (📖 p. 101)

### Main work

- Remove screws ① and ②.
- Raise rear fairing ③ slightly.

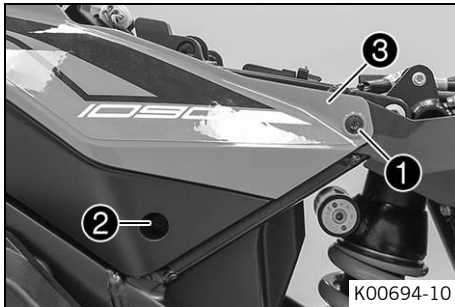

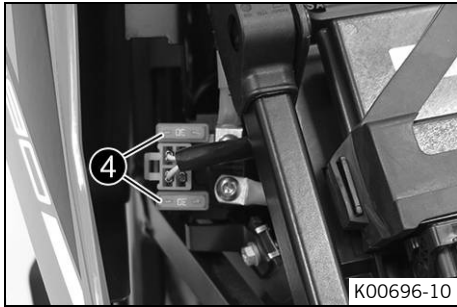

- Take off protection caps ④.

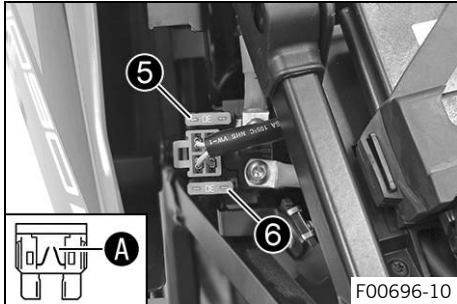

- Remove faulty main fuse ⑤.

---

**i** **Info**

You can recognize a faulty fuse by a burned-out fuse wire **A**.  
A spare fuse ⑥ is located in the starter relay.  
The main fuse protects all power consumers of the vehicle.

---

- Install a new main fuse.

Fuse (58011109130) (📖 p. 210)

- Check that the electrical equipment is functioning properly.
- Mount the protection caps.

---

**i** **Tip**

Insert a new spare fuse into the starter relay to have it available when needed.

---

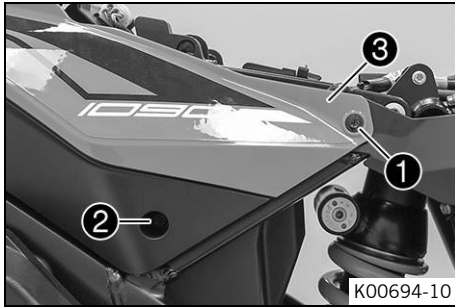

- Position rear fairing ③.
- ✓ Heat protector is correctly positioned.
- Mount and tighten screw ②.

Guideline

Rear fairing screw	M5x12	3.5 Nm (2.58 lbf ft)
--------------------	-------	-------------------------

- Mount and tighten screw ①.

Guideline

Rear fairing screw	M5x17	3.5 Nm (2.58 lbf ft)
--------------------	-------	-------------------------

**Finishing work**

- Mount the seat. (📖 p. 101)
- Set the time and date.

## 16.6 Changing the fuses in the fuse box



**Warning**

**Fire hazard** Incorrect fuses overload the electrical system.

- Only use fuses with the required ampere value.
- Do not bypass or repair fuses.



**Info**

The fuse box containing the fuses of individual power consumers is located under the seat.

### Preparatory work

- Switch off all power consumers and switch off the engine.
- Remove the seat. (📖 p. 101)

### Main work

- Open fuse box cover ❶.

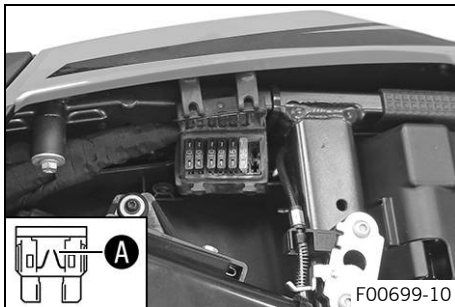
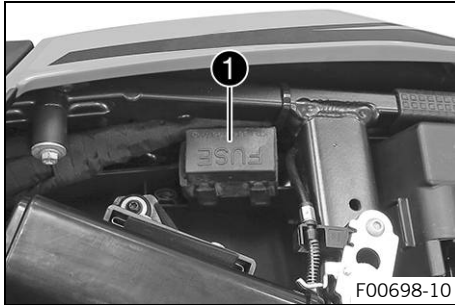

- Check the fuses.

### **i** Info

A defective fuse is indicated by a burned-out fuse wire **A**.

- Remove the defective fuse.

### Guideline

Fuses <b>res</b> - 10 A - spare fuses
Fuse <b>1</b> - 10 A - power supply for control units and components
Fuse <b>2</b> - 10 A - optional auxiliary equipment
Fuse <b>3</b> - 15 A - ABS hydraulic unit
Fuse <b>4</b> - 25 A - ABS return pump
Fuse <b>5</b> - not assigned

- Use spare fuses with the correct rating only.



Fuse (58011109110) (📖 p. 210)
Fuse (58011109115) (📖 p. 210)
Fuse (58011109125) (📖 p. 210)

**Tip**

Insert a spare fuse so that it is available if needed.

- Check that the power consumer is functioning properly.
- Close the fuse box cover.

**Finishing work**

- Mount the seat. (📖 p. 101)

## 16.7 Removing the headlight mask with the headlight

**Preparatory work**

- Switch off all power consumers and switch off the engine.
- Remove the seat. (📖 p. 101)
- Remove the front side cover. (📖 p. 113)
- Remove the tank cover. (📖 p. 123)
- Remove the mask spoiler. 🗑️ (📖 p. 116)
- Remove the wind shield. (📖 p. 127)

# 16 ELECTRICAL SYSTEM

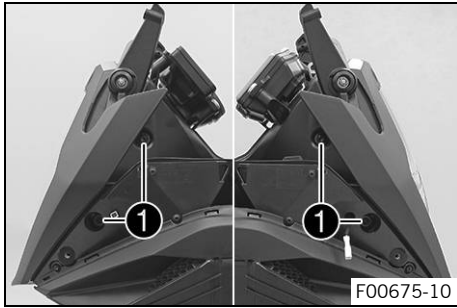

## Main work

- Remove screws ①.
- Remove the headlight mask forward.

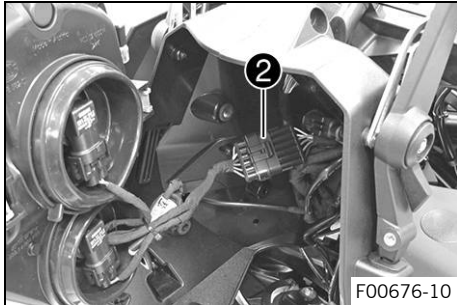

- Disconnect plug-in connector ②.
- Place the headlight mask onto a soft cloth so that the headlight is not damaged.

## 16.8 Installing the headlight mask with the headlight

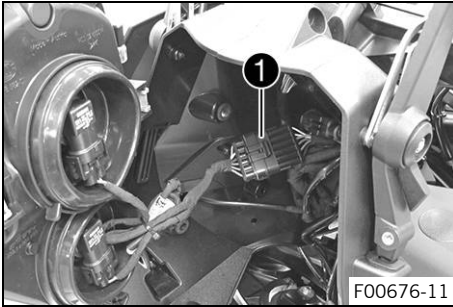

### Main work

- Connect plug-in connector **1** of the headlight.
- Check that the lighting is functioning properly.
- Position the headlight mask.

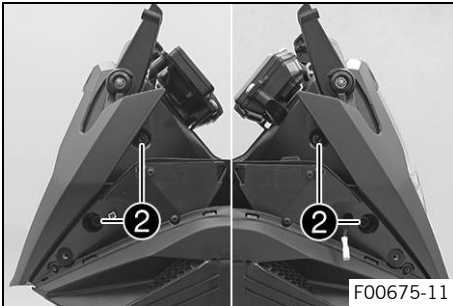

- Mount and tighten screws **2**.

### Guideline

Screw, headlight	M6	5 Nm (3.7 lbf ft)
------------------	----	-------------------

### Finishing work

- Install the wind shield. (🔧 p. 127)
- Install the mask spoiler. 🪛 (🔧 p. 118)
- Install the tank cover. (🔧 p. 125)
- Install the front side cover. (🔧 p. 114)
- Mount the seat. (🔧 p. 101)
- Check the headlight setting. (🔧 p. 174)

## 16.9 Changing the low beam bulb

### Note

**Damage to reflector** Grease on the reflector reduces the brightness.

Grease on the lamp will evaporate due to the heat and be deposited on the reflector.

- Clean and degrease the bulbs before mounting.
- Do not touch the bulbs with your bare hands.

### Preparatory work

- Switch off all power consumers and switch off the engine.
- Remove the seat. (📖 p. 101)
- Remove the front side cover. (📖 p. 113)
- Remove the tank cover. (📖 p. 123)
- Remove the mask spoiler. 🗜️ (📖 p. 116)
- Remove the wind shield. (📖 p. 127)
- Remove the headlight mask with the headlight. (📖 p. 167)

### Main work

- Push headlight bulb ❶ lightly into the bulb socket, turn it all the way counterclockwise, and pull it out.
- Unplug connector ❷.

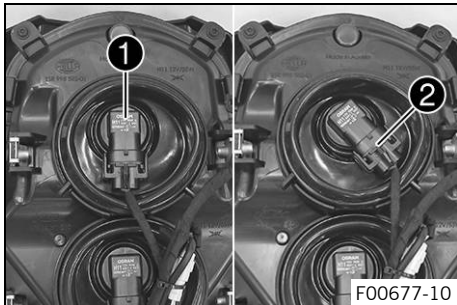

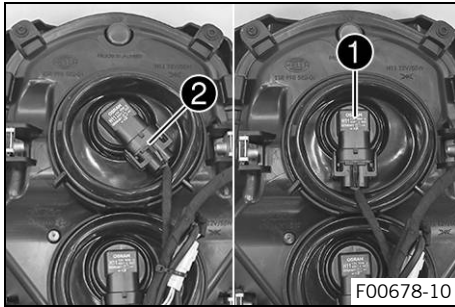

- Plug connector ② into the new headlight bulb.

Low beam (H11/socket PGJ19-2) (📖 p. 210)

- Position headlight bulb ① into the bulb socket and turn it all the way clockwise.  
✓ The headlight bulb is locked into the bulb socket.

### Finishing work

- Install the headlight mask with the headlight. (📖 p. 169)
- Install the wind shield. (📖 p. 127)
- Install the mask spoiler. 🗑️ (📖 p. 118)
- Install the tank cover. (📖 p. 125)
- Install the front side cover. (📖 p. 114)
- Mount the seat. (📖 p. 101)
- Check the headlight setting. (📖 p. 174)

## 16.10 Changing the high beam bulb

### Note

**Damage to reflector** Grease on the reflector reduces the brightness.

Grease on the lamp will evaporate due to the heat and be deposited on the reflector.

- Clean and degrease the bulbs before mounting.
- Do not touch the bulbs with your bare hands.

## Preparatory work

- Switch off all power consumers and switch off the engine.
- Remove the seat. (📖 p. 101)
- Remove the front side cover. (📖 p. 113)
- Remove the tank cover. (📖 p. 123)
- Remove the mask spoiler. 🛠️ (📖 p. 116)
- Remove the wind shield. (📖 p. 127)
- Remove the headlight mask with the headlight. (📖 p. 167)

## Main work

- Push headlight bulb ❶ lightly into the bulb socket, turn it all the way counterclockwise, and pull it out.
- Unplug connector ❷.

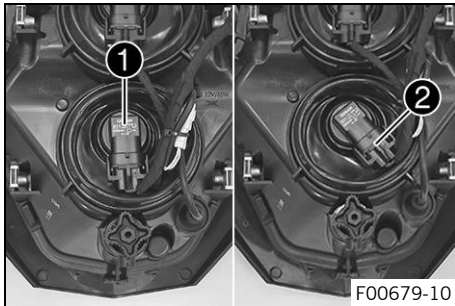

- Plug connector ❷ into the new headlight bulb.

High beam (H11/socket PGJ19-2) (📖 p. 210)

- Position headlight bulb ❶ into the bulb socket and turn it all the way clockwise.  
✓ The headlight bulb is locked into the bulb socket.

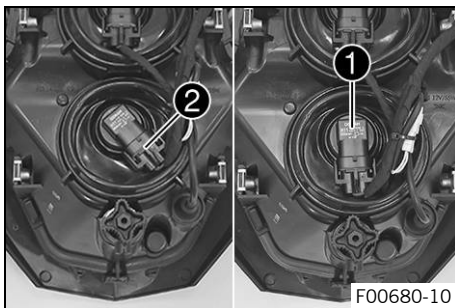

## Finishing work

- Install the headlight mask with the headlight. (📖 p. 169)
- Install the wind shield. (📖 p. 127)
- Install the mask spoiler. 🗑️ (📖 p. 118)
- Install the tank cover. (📖 p. 125)
- Install the front side cover. (📖 p. 114)
- Mount the seat. (📖 p. 101)
- Check the headlight setting. (📖 p. 174)

## 16.11 Changing the turn signal bulb

### Note

**Damage to reflector** Grease on the reflector reduces the brightness.

Grease on the lamp will evaporate due to the heat and be deposited on the reflector.

- Clean and degrease the bulbs before mounting.
- Do not touch the bulbs with your bare hands.

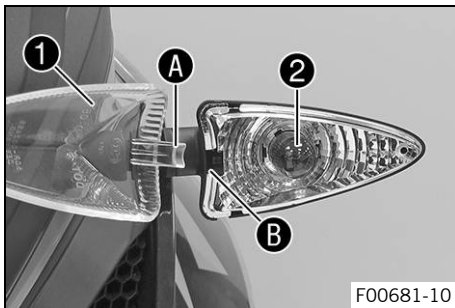

- Remove the screw on the front of the diffuser.
- Carefully take off diffuser ①.
- Push bulb ② lightly into the socket, turn approx. 30° counterclockwise, and pull it out of the socket.



### Info

Do not touch the reflector with your fingers and keep it free from grease.

- Lightly push the new lamp into the socket and turn all the way clockwise.

Turn signal (RY10W / socket BAU15s) (📖 p. 210)

- Check that the turn signal is functioning properly.
- Position the diffuser.



**Info**

Insert catch **A** into recess **B**.

- Insert the screw and first turn counterclockwise until it engages in the thread with a small jerk. Tighten the screw lightly.

## 16.12 Checking the headlight setting

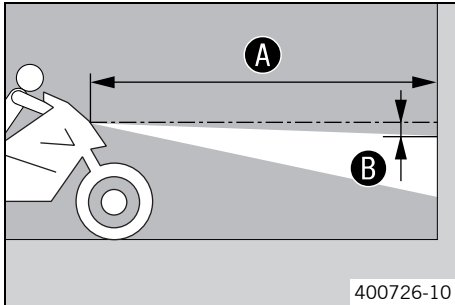

- Park the vehicle on a horizontal surface in front of a light-colored wall and make a mark at the height of the center of the low beam headlight.
- Make another mark at a distance **B** under the first mark.

Guideline

Distance <b>B</b>	5 cm (2 in)
-------------------	-------------

- Position the vehicle perpendicular to the wall at a distance **A** from the wall and switch on the low beam.

Guideline

Distance <b>A</b>	5 m (16 ft)
-------------------	-------------

- The rider, with luggage and passenger if applicable, now mounts the motorcycle.
- Check the headlight setting.

The light-dark boundary must lie exactly on the lower mark when the motorcycle is ready to operate with the rider mounted along with any luggage and a passenger if applicable.

- » If the boundary between light and dark does not meet specifications:
  - Adjust the headlight range. (📖 p. 175)



## 16.13 Adjusting the headlight range

### Preparatory work

- Check the headlight setting. (📖 p. 174)
- Remove the bottom triple clamp cover. (📖 p. 111)

### Main work

- Turn adjusting screw **1** to adjust the headlight range.

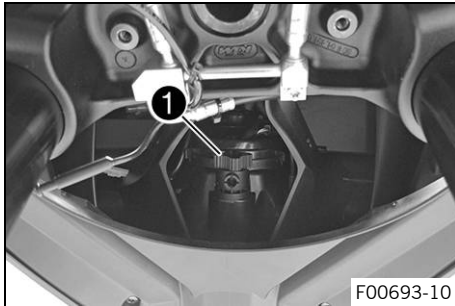

### **i** Info

Turn clockwise to increase the headlight range; turn counterclockwise to reduce the headlight range.

If you have a payload, you may have to correct the headlight range.

- Set the headlight to marking **B**.

### Guideline

The light-dark boundary must lie exactly on the lower mark **B** when the motorcycle is ready to operate with the rider mounted along with any luggage and a passenger if applicable.

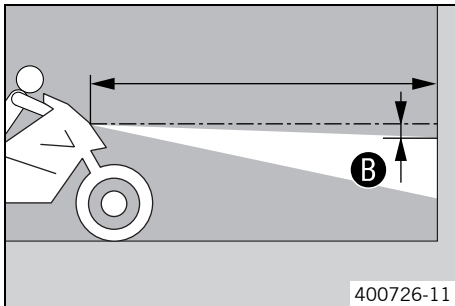

### Finishing work

- Install the bottom triple clamp cover. (📖 p. 112)

## 16.14 Activating/deactivating the ignition key

### **i** Info

The orange programming key must only be used for activating and deactivating!

If a black ignition key is lost or needs to be replaced, the individual black ignition keys need to be enabled or disabled using the orange programming key. This prevents the vehicle from being operated with the lost black ignition key.

You can activate or deactivate up to four black ignition keys. Only the black ignition keys programmed during an activation procedure are valid. All black ignition keys not programmed during the activation procedure are invalid, but can be reprogrammed in a further activation procedure.

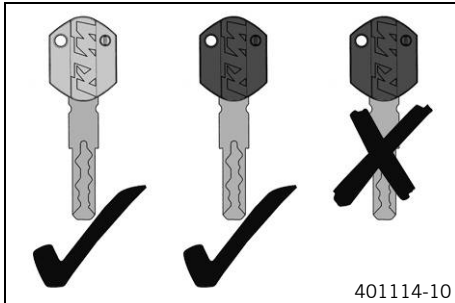

### **Loss of a black ignition key (additional black ignition keys are available):**

The following procedure deactivates all activated black ignition keys that are not included in the procedure.

- Press the emergency OFF switch to the position **ON** ○.
  
- Insert the orange programming key in the ignition lock.
- Switch on the ignition by turning the orange programming key to the **ON** position ○.
  - ✓ Immobilizer indicator lamp ■ lights up.
- Switch off the ignition by turning the orange programming key to the **OFF** position ⊗.
- Pull out the orange programming key.
- Insert the black ignition key in the ignition lock.
- Switch on the ignition by turning the black ignition key to the position **ON** ○.
  - ✓ Immobilizer indicator lamp ■ lights up.

- Switch off the ignition by turning the black ignition key to the position **OFF** ☒.
- Remove the black ignition key.
- Insert the orange programming key in the ignition lock.
- Switch on the ignition by turning the orange programming key to the **ON** position ○.
- ✓ The immobilizer indicator lamp ■ flashes according to the number of functional black ignition keys including the orange programming key. In this case, it flashes twice.
- Switch off the ignition by turning the orange programming key to the **OFF** position ☒.
- Pull out the orange programming key.
- ✓ The lost black ignition key is deactivated.
- ✓ The existing black ignition key is reactivated.

**Loss of all black ignition keys (no black ignition keys are available):**

This procedure is important to prevent misuse of the lost black ignition key.

- Press the emergency OFF switch to the position **ON** ○.

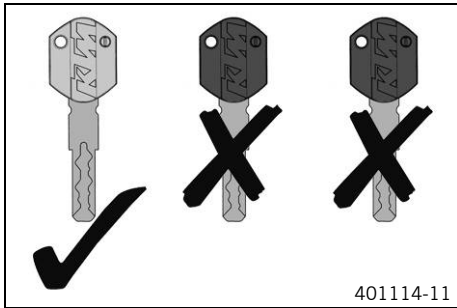



- Insert the orange programming key in the ignition lock.
- Switch on the ignition by turning the orange programming key to the **ON** position ○.
  - ✓ Immobilizer indicator lamp ■ lights up.
- Switch off the ignition by turning the orange programming key to the **OFF** position ⊗.
- Switch on the ignition by turning the orange programming key to the **ON** position ○.
  - ✓ The immobilizer indicator lamp ■ flashes according to the number of functional black ignition keys including the orange programming key. In this case, it flashes once since all black ignition keys are deactivated.
- Switch off the ignition by turning the orange programming key to the **OFF** position ⊗.
- Pull out the orange programming key.
  - ✓ All black ignition keys are deactivated.
- Order a new black ignition key according to the key number on the **KEYCODECARD** and activate it.

### To activate up to three black ignition keys:

- Press the emergency OFF switch to the position **ON** ○.
- Insert the orange programming key in the ignition lock.
- Switch on the ignition by turning the orange programming key to the **ON** position ○.
  - ✓ Immobilizer indicator lamp ■ lights up.
- Switch off the ignition by turning the orange programming key to the **OFF** position ⊗.
- Pull out the orange programming key.
- Insert the black ignition key in the ignition lock.
- Switch on the ignition by turning the black ignition key to the position **ON** ○.
  - ✓ Immobilizer indicator lamp ■ lights up.
- Switch off the ignition by turning the black ignition key to the position **OFF** ⊗.
- Remove the black ignition key.
- If two other black ignition keys are to be activated, repeat the last steps with the respective ignition key.

- If the last black ignition key was activated, insert the orange programming key into the ignition lock.
- Switch on the ignition by turning the orange programming key to the **ON** position ○.
- ✓ The immobilizer indicator lamp ■ flashes according to the number of functional black ignition keys including the orange programming key.
- Switch off the ignition by turning the orange programming key to the **OFF** position ⊗.
- Pull out the orange programming key.



### Info

Activation of the ignition key is finished.

---

#### To activate four black ignition keys:

- Press the emergency OFF switch to the position **ON** ○.
- Insert the orange programming key in the ignition lock.
- Switch on the ignition by turning the orange programming key to the **ON** position ○.
- ✓ Immobilizer indicator lamp ■ lights up.
- Switch off the ignition by turning the orange programming key to the **OFF** position ⊗.
- Pull out the orange programming key.
- Insert the black ignition key in the ignition lock.
- Switch on the ignition by turning the black ignition key to the position **ON** ○.
- ✓ Immobilizer indicator lamp ■ lights up.
- Switch off the ignition by turning the black ignition key to the position **OFF** ⊗.
- Remove the black ignition key.
- If three other black ignition keys are to be activated, repeat the last steps with the respective ignition key.



**Info**

After the fourth black ignition key has been activated, programming is finished.

---

## 17.1 Checking the coolant level in the compensating tank



### Warning

**Danger of scalding** During motorcycle operation, the coolant gets very hot and is under pressure.

- Do not open the radiator, the radiator hoses or other cooling system components if the engine or the cooling system are at operating temperature.
- Allow the cooling system and the engine to cool down before you open the radiator, the radiator hoses or other components of the cooling system.
- In the event of scalding, rinse the area affected immediately with lukewarm water.



### Warning

**Danger of poisoning** Coolant is toxic and a health hazard.

- Keep coolant out of the reach of children.
- Do not allow coolant to come into contact with the skin, the eyes and clothing.
- Consult a doctor immediately if coolant is swallowed.
- Rinse the affected area immediately with plenty of water in the event of contact with the skin.
- Rinse eyes thoroughly with water and consult a doctor immediately if coolant gets into the eyes.
- Change clothing if coolant spills onto your clothing.

### Condition

The engine is cold.

The radiator is completely full.

- Park the motorcycle on a horizontal surface.

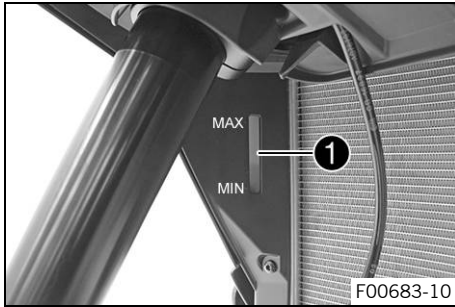

- Check the coolant level in the compensating tank ①.

The coolant level must be between **MIN** and **MAX**.

- » If there is no coolant in the compensating tank:

- Check the cooling system for leaks. 🛠️



### Info

Do not start up the motorcycle!

- Add coolant/bleed the cooling system. 🛠️
- » If the coolant in the compensating tank is not at the required level, but the tank is not empty:
  - Correct the coolant level in the compensating tank. (📖 p. 182)

## 17.2 Correcting the coolant level in the compensating tank



### Warning

**Danger of scalding** During motorcycle operation, the coolant gets very hot and is under pressure.

- Do not open the radiator, the radiator hoses or other cooling system components if the engine or the cooling system are at operating temperature.
- Allow the cooling system and the engine to cool down before you open the radiator, the radiator hoses or other components of the cooling system.
- In the event of scalding, rinse the area affected immediately with lukewarm water.





## Warning

**Danger of poisoning** Coolant is toxic and a health hazard.

- Keep coolant out of the reach of children.
- Do not allow coolant to come into contact with the skin, the eyes and clothing.
- Consult a doctor immediately if coolant is swallowed.
- Rinse the affected area immediately with plenty of water in the event of contact with the skin.
- Rinse eyes thoroughly with water and consult a doctor immediately if coolant gets into the eyes.
- Change clothing if coolant spills onto your clothing.

---

## Condition

The engine is cold.

The radiator is completely full.

## Preparatory work

- Check the coolant level in the compensating tank. (📖 p. 181)
- Remove the front side cover. (📖 p. 113)



---

## Info

Only disassemble the right-hand side.

---

## Main work

- Remove the cover ❶ of the compensating tank.





- Add coolant until the coolant reaches the specified level.

#### Guideline

The coolant level must be between **MIN** and **MAX**.

Coolant (📖 p. 216)

- Mount the cover of the compensating tank.

#### Finishing work

- Install the front side cover. (📖 p. 114)

## 18.1 "Drive Mod"

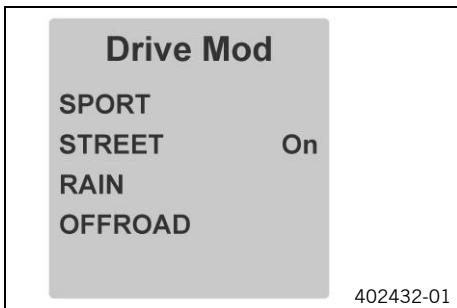

### Possible states

- SPORT – Homologated performance with very direct response; the traction control allows greater slip on the rear wheel
- STREET – Homologated performance with balanced response; the traction control allows normal slip on the rear wheel
- RAIN – Reduced homologated performance for better ridability; the traction control allows normal slip on the rear wheel
- OFFROAD (optional) – Reduced homologated performance for better ridability; the traction control allows high slip on the rear wheel

Various vehicle tunings can be selected in the "**Drive Mod**" menu. You can choose from "**SPORT**", "**STREET**", "**RAIN**" and "**OFFROAD**" (optional).

The drive mode selected last is displayed on the right in the segment display.



### Info

The drive mode selection has no influence on the ABS.

## 18.2 Traction control (TC)

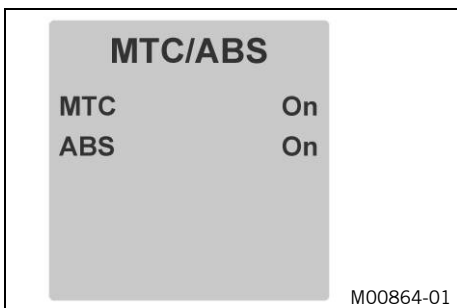

The traction control (TC) lowers the engine torque in case of loss of traction in the rear wheel. Depending on the traction control setting, a slight slip on the rear wheel may be desirable. Example: offroad (optional).





### Info

When traction control is switched off, the rear wheel may spin during high acceleration and on surfaces with low grip.  
After the ignition is switched back on, traction control is enabled again.

Traction control is controlled via the "**Drive Mod**" (p. 185) menu on the combination instrument. Traction control can be switched off in the "**MTC/ABS**" menu.

**Info**

When traction control is active, the TC lamp  flashes.  
When traction control is switched off, the TC lamp  is lit.

---

## 19.1 Checking the engine oil level



### Info

Oil consumption depends on the riding style and the operating conditions.

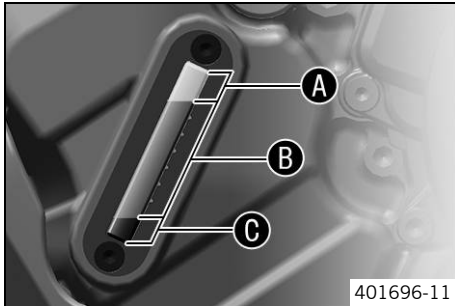

### Condition

The engine is at operating temperature.

### Preparatory work

- Stand the motorcycle upright on a horizontal surface.

### Main work

- Check the engine oil level in the engine oil level viewer.



### Info

After switching off the engine, wait one minute before checking the level.

The engine oil level should be in the upper part of the range **B** of the engine oil level viewer.

- » When the engine oil level is in area **A** of the engine oil level viewer:
  - Do not add engine oil.
- » When the engine oil level is in area **B** of the engine oil level viewer:
  - Engine oil can be added.
- » When the engine oil level is in area **C** of the engine oil level viewer:
  - Add engine oil. (🗨️ p. 192)

## 19.2 Changing the engine oil and oil filter, cleaning the oil screens ↩



### Warning

**Danger of scalding** Engine and gear oil get very hot when the motorcycle is ridden.

- Wear suitable protective clothing and safety gloves.
- In the event of scalding, rinse the area affected immediately with lukewarm water.



### Warning

**Environmental hazard** Hazardous substances cause environmental damage.

- Dispose of oils, grease, filters, fuel, cleaning agents, brake fluid, etc., correctly and in compliance with the applicable regulations.

### Preparatory work

- Remove the engine guard. (📖 p. 128)

### Main work

- Stand the motorcycle on its side stand on a horizontal surface.
- Place a suitable container under the engine.
- Remove oil drain plugs ❶ with the magnets, O-rings, and oil screens.

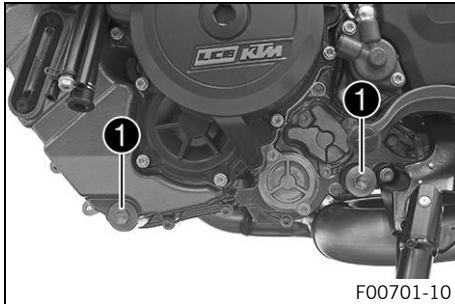

# 19 SERVICE WORK ON THE ENGINE

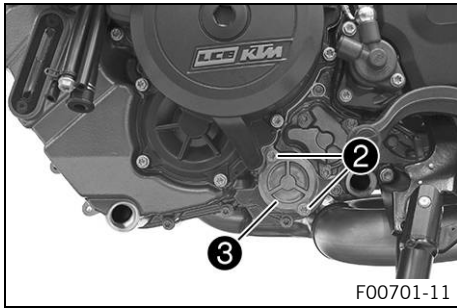

- Remove screws ②. Remove oil filter cover ③ with the O-ring.

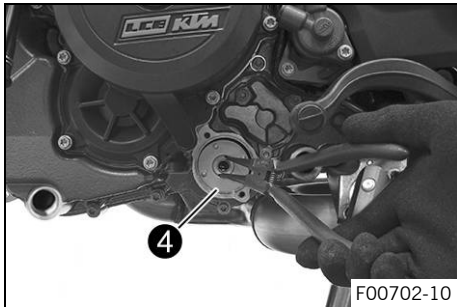

- Pull oil filter ④ out of the oil filter housing.

Circlip pliers reverse (51012011000)

- Completely drain the engine oil.
- Thoroughly clean the parts and sealing surface.

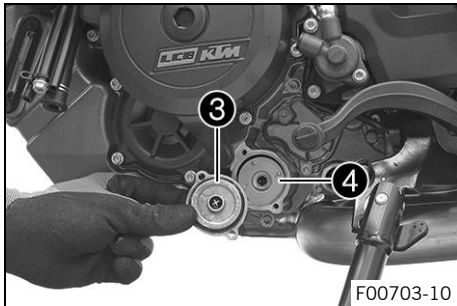

- Insert oil filter ④.



### Info

Only insert the oil filter by hand.

- Lubricate the O-ring of the oil filter cover. Mount oil filter cover ③.

# 19 SERVICE WORK ON THE ENGINE

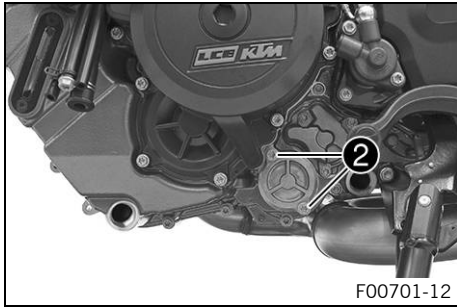

- Mount and tighten screws ②.

Guideline

Remaining engine screws	M5	6 Nm (4.4 lbf ft)
-------------------------	----	-------------------

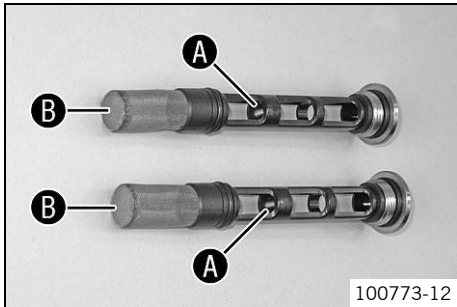

- Thoroughly clean magnets ① and oil screens ② of the oil drain plugs.

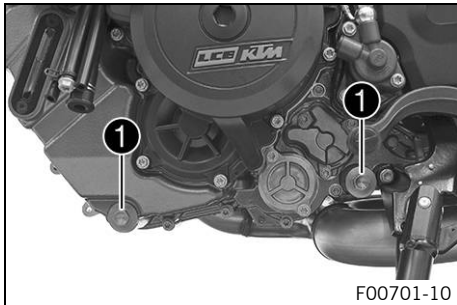

- Mount and tighten oil drain plugs ① with the magnets, O-rings, and oil screens.

Guideline

Oil drain plug	M20x1.5	20 Nm (14.8 lbf ft)
----------------	---------	------------------------



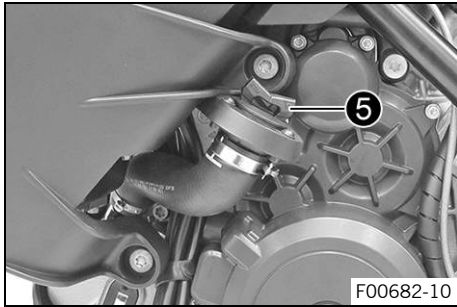

- Add the oil quantity in two separate operations.

Engine oil	3.60 l (3.8 qt.)	Outside temperature: ≥ 0 °C (≥ 32 °F)	Engine oil (SAE 10W/50) (📖 p. 217)
		Outside temperature: < 0 °C (< 32 °F)	Engine oil (SAE 5W/40) (📖 p. 217)

- Remove screw plug 5 and fill in engine oil.

Engine oil (1st quantity) approx.	3.0 l (3.2 qt.)	Outside temperature: ≥ 0 °C (≥ 32 °F)	Engine oil (SAE 10W/50) (📖 p. 217)
		Outside temperature: < 0 °C (< 32 °F)	Engine oil (SAE 5W/40) (📖 p. 217)

- Mount screw plug 5.



**Danger**

**Danger of poisoning** Exhaust gases are toxic and inhaling them may result in unconsciousness and death.

- Always make sure there is sufficient ventilation when running the engine.
  - Use an effective exhaust extraction system when starting or running the engine in an enclosed space.
- 
- Start the engine and check that it is oil-tight.

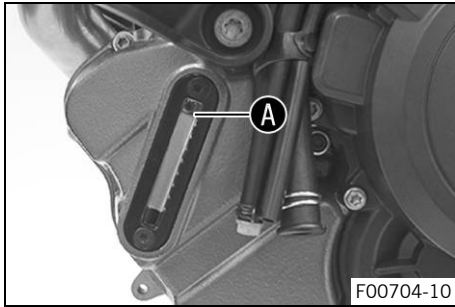

- Remove the screw plug and add the remaining engine oil to upper marking **A** on the engine oil level viewer.
- Mount the screw plug.



### **Danger**

**Danger of poisoning** Exhaust gases are toxic and inhaling them may result in unconsciousness and death.

- Always make sure there is sufficient ventilation when running the engine.
  - Use an effective exhaust extraction system when starting or running the engine in an enclosed space.
- 
- Start the engine and check that it is oil-tight.

### **Finishing work**

- Check the engine oil level. (📖 p. 187)
- Install the engine guard. (📖 p. 128)

## 19.3 Adding engine oil



### **Info**

Too little engine oil or poor-quality engine oil results in premature wear to the engine. The engine may be damaged if the engine oil level is too high.

### **Condition**

The engine is at operating temperature.

### **Preparatory work**

- Stand the motorcycle upright on a horizontal surface.
- Check the engine oil level. (📖 p. 187)

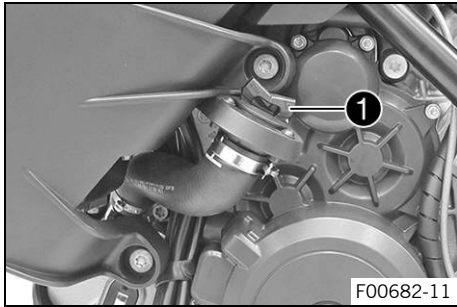

## Main work

- Remove screw plug 1.

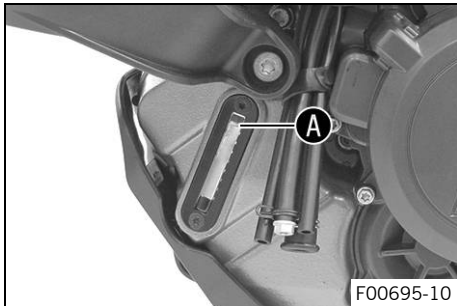

- Add engine oil to the upper marking A on the engine oil level viewer.

## Condition

Outside temperature:  $\geq 0\text{ }^{\circ}\text{C}$  ( $\geq 32\text{ }^{\circ}\text{F}$ )

Engine oil (SAE 10W/50) (📖 p. 217)

## Condition

Outside temperature:  $< 0\text{ }^{\circ}\text{C}$  ( $< 32\text{ }^{\circ}\text{F}$ )

Engine oil (SAE 5W/40) (📖 p. 217)



## Info

In order to achieve optimal engine performance, it is not advisable to mix different engine oils.

KTM recommends changing the engine oil.

- Mount the screw plug.



## **Danger**

**Danger of poisoning** Exhaust gases are toxic and inhaling them may result in unconsciousness and death.

- Always make sure there is sufficient ventilation when running the engine.
- Use an effective exhaust extraction system when starting or running the engine in an enclosed space.

- 
- Start the engine and check that it is oil-tight.

## **Finishing work**

- Check the engine oil level. (📖 p. 187)

## 20.1 Cleaning motorcycle

### Note

**Material damage** Components become damaged or destroyed if a pressure cleaner is used incorrectly.

The high pressure forces water into the electrical components, connectors, throttle cables, and bearings, etc. Pressure which is too high causes malfunctions and destroys components.

- Do not direct the water jet directly on to electrical components, connectors, throttle cables or bearings.
- Maintain a minimum distance between the nozzle of the pressure cleaner and the component.

Minimum clearance 60 cm (23.6 in)



### Warning

**Environmental hazard** Hazardous substances cause environmental damage.

- Dispose of oils, grease, filters, fuel, cleaning agents, brake fluid, etc., correctly and in compliance with the applicable regulations.



### Info

If you clean the motorcycle regularly, its value and appearance will be maintained over a long period. Avoid direct sunshine on the motorcycle during cleaning.

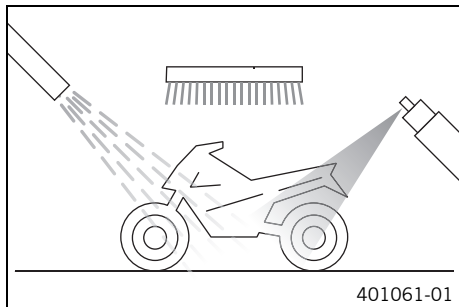

- Close off the exhaust system to keep water from entering.
- First remove coarse dirt particles with a gentle spray of water.
- Spray very dirty areas with a normal motorcycle cleaner and then clean with a brush.

Motorcycle cleaner (📖 p. 219)

### **i** Info

Use warm water containing normal motorcycle cleaner and a soft sponge. Never apply motorcycle cleaner to a dry vehicle; always rinse the vehicle with water first. If the vehicle was operated in road salt, clean it with cold water. Warm water would enhance the corrosive effects of salt.

- After rinsing the motorcycle with a gentle spray of water, allow it to dry thoroughly.
- Remove the closure of the exhaust system.



### **Warning**

**Danger of accidents** Moisture and dirt impair the brake system.

- Brake carefully several times to dry out and remove dirt from the brake linings and the brake discs.
- After cleaning, ride the vehicle a short distance until the engine warms up.

### **i** Info

The heat produced causes water at inaccessible locations in the engine and on the brake system to evaporate.

- Push back the protection caps of the handlebar controls to allow any water that has penetrated to evaporate.
- After the motorcycle has cooled off, lubricate all moving parts and bearings.
- Clean the chain. (📖 p. 102)

- Treat bare metal parts (except for brake discs and exhaust system) with corrosion inhibitor.

Preserving materials for paints, metal and rubber (📖 p. 220)

- Treat the painted parts with a mild paint polish.

Perfect Finish and high gloss polish for paints (📖 p. 220)



### Info

Do not polish plastic parts that are matte when the vehicle is delivered as this would seriously impair the material quality.

- Treat the plastic parts and powder-coated parts with a mild cleaning and care product.

Special cleaner for glossy and matte paint finishes, metal and plastic surfaces (📖 p. 220)

- Oil the ignition/steering lock, tank lock, and seat lock.

Universal oil spray (📖 p. 220)

## 20.2 Checks and maintenance steps for winter operation



### Info

If you use the motorcycle in winter, you must expect salt on the roads. You should therefore take precautions against aggressive road salt.

If the vehicle was operated in road salt, clean it with cold water after riding. Warm water would enhance the corrosive effects of salt.

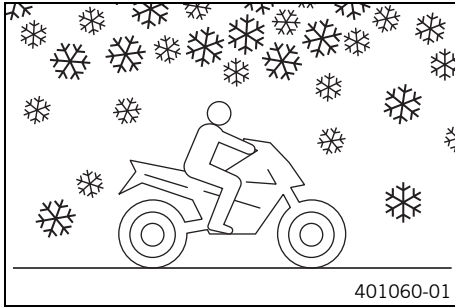

- Clean the motorcycle. (📖 p. 195)
  - Clean the brakes.
- 



### Info

After **EVERY** trip on salted roads, thoroughly wash the brake calipers and brake linings with cold water and dry carefully. This should be done after the parts are cooled down and while they are installed.

After riding on salted roads, thoroughly wash the motorcycle with cold water and dry it well.

---

- Treat the engine, the swingarm, and all other bare or galvanized parts (except brake discs) with a wax-based corrosion inhibitor.
- 



### Info

Corrosion inhibitor must not come into contact with the brake discs. This would severely lower the braking effect.

---

- Clean the chain. (📖 p. 102)



## 21.1 Storage

### **i** Info

If you plan to garage the motorcycle for a longer period, perform the following steps or have them performed. Before storing the motorcycle, check all parts for function and wear. If service, repairs or replacements are necessary, you should do this during the storage period (less workshop overload). In this way, you can avoid long workshop waiting times at the start of the new season.

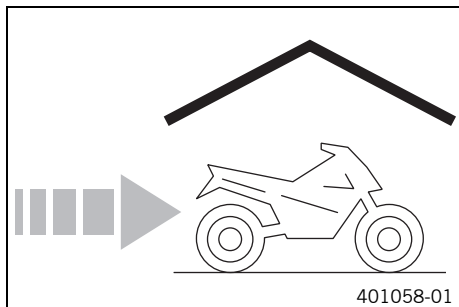

- When refueling for the last time before taking the motorcycle out of service, add fuel additive.

Fuel additive (📖 p. 219)
--------------------------

- Refuel. (📖 p. 89)
- Clean the motorcycle. (📖 p. 195)
- Change the engine oil and oil filter and clean the oil screens. 🛠️ (📖 p. 188)
- Check the coolant fill level and antifreeze. 🛠️
- Check the tire air pressure. (📖 p. 152)
- Remove the battery. 🛠️ (📖 p. 155)

#### Guideline

Storage temperature of battery without direct sunshine	0... 35 °C (32... 95 °F)
--	--------------------------

- Recharge the battery. 🛠️ (📖 p. 159)
- Store the vehicle in a dry location that is not subject to large fluctuations in temperature.
- Cover the vehicle with a tarp or similar cover that is permeable to air.

---

**i** **Info**

Do not use non-porous materials since they prevent humidity from escaping, thus causing corrosion.

Avoid running the engine for a short time only. Since the engine cannot warm up properly, the water vapor produced during combustion condenses and causes valves and the exhaust system to rust.

---

## 21.2 Preparing for use after storage

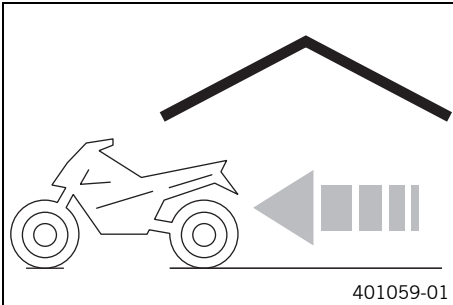

- Install the battery. 🛠️ (📖 p. 157)

---

**i** **Info**

If the battery was removed, the time and date must be set.

- 
- Perform checks and maintenance measures when preparing for use. (📖 p. 78)
  - Take a test ride.

Faults	Possible cause	Action
Combination instrument shows nothing on the display	Fuse 1 blown	– Change the fuses in the fuse box. (🔧 p. 165)
	Main fuse burned out	– Change the main fuse. (🔧 p. 163)
	The battery is discharged	– Recharge the battery. 🛡️ (🔧 p. 159) – Check the quiescent current. 🛡️
	Ignition/steering lock is faulty	– Check the ignition/steering lock. 🛡️
Engine does not crank when the electric starter button is pressed	Emergency OFF switch is off	– Press the emergency OFF switch to the position <b>ON</b> ○.
	Operating error	– Carry out the start procedure. (🔧 p. 79)
	The battery is discharged	– Recharge the battery. 🛡️ (🔧 p. 159) – Check the quiescent current. 🛡️
	Safety start system is faulty	– Read out the fault memory using the KTM diagnostics tool. 🛡️
	ICU is not enabled	– Activate the ICU. 🛡️
	CAN bus communication error	– Read out the fault memory using the KTM diagnostics tool. 🛡️
	Fault in EFI control unit.	– Read out the fault memory using the KTM diagnostics tool. 🛡️
	Fault in MCU control unit.	– Read out the fault memory using the KTM diagnostics tool. 🛡️
Engine turns only if the clutch lever is drawn	The vehicle is in gear	– Shift the transmission to idle <b>N</b> .
	Safety start system is faulty	– Read out the fault memory using the KTM diagnostics tool. 🛡️
Engine turns although a gear is engaged	Safety start system is faulty	– Read out the fault memory using the KTM diagnostics tool. 🛡️
Engine turns but does not start	The plug-in connection of the fuel hose connection is not connected	– Connect the plug-in connection of the fuel line.

Faults	Possible cause	Action
Engine turns but does not start	Fault in fuel injection system	– Read out the fault memory using the KTM diagnostics tool. 🛠️
	Fuel quality is insufficient	– Add suitable fuel.
Engine dies during the trip	Lack of fuel	– Refuel. (📖 p. 89)
	Fault in fuel injection system	– Read out the fault memory using the KTM diagnostics tool. 🛠️
The engine warning lamp lights up/flashes	Fault in fuel injection system	– Read out the fault memory using the KTM diagnostics tool. 🛠️
The ABS warning lamp lights up	ABS fuse is blown	– Change the fuses in the fuse box. (📖 p. 165)
	Wheel speeds of front and rear wheels differ greatly	– Stop, switch off the ignition, start again.
	Malfunction in ABS	– Read out the fault memory using the KTM diagnostics tool. 🛠️
High oil consumption	Engine oil level too high	– Check the engine oil level. (📖 p. 187)
	Engine oil too thin (low viscosity)	– Change the engine oil and oil filter and clean the oil screens. 🛠️ (📖 p. 188)
The battery is discharged	The hazard warning flasher is switched on	– Switch off the hazard warning flasher. – Recharge the battery. 🛠️ (📖 p. 159)
	Battery is not charged by alternator	– Check the charging voltage. 🛠️
	Ignition was not switched off when vehicle was parked	– Recharge the battery. 🛠️ (📖 p. 159)

## 23.1 Engine

Design	2-cylinder 4-stroke Otto engine, 75° V arrangement, water-cooled
Displacement	1,050 cm <sup>3</sup> (64.08 cu in)
Stroke	63 mm (2.48 in)
Bore	103 mm (4.06 in)
Compression ratio	13.0:1
Idle speed	1,300... 1,500 rpm
Control	DOHC, 4 valves per cylinder, chain-driven
Valve - valve plate diameter	
Intake	42 mm (1.65 in)
Exhaust	34 mm (1.34 in)
Valve clearance	
Exhaust at: 20 °C (68 °F)	0.25... 0.30 mm (0.0098... 0.0118 in)
Intake at: 20 °C (68 °F)	0.10... 0.15 mm (0.0039... 0.0059 in)
Crankshaft bearing	Sleeve bearing
Conrod bearing	Sleeve bearing
Piston	Forged light alloy
Piston ring	1 upper compression (rectangular) ring, 1 lower compression ring, 1 oil scraper ring
Engine lubrication	Pressure circulation lubrication with three rotary pumps
Primary transmission	40:76
Clutch	Antihopping clutch in oil bath/hydraulically operated
Transmission	6-speed claw gears
Transmission ratio	

1st gear	12:35
2nd gear	15:32
3rd gear	18:30
4th gear	20:27
5th gear	24:27
6th gear	27:26
Mixture preparation	Electronically controlled fuel injection
Ignition system	Contactless controlled fully electronic ignition with digital ignition adjustment
Alternator	12 V, 450 W
Spark plug	
Inside spark plug	NGK LKAR9BI-10
Outside spark plug	NGK LMAR7DI-10
Electrode gap, spark plug	1.0 mm (0.039 in)
Cooling	Water cooling, permanent circulation of coolant by water pump
Cold start device	Electric starter

## 23.2 Engine tightening torques

Screw, damping plate	<b>EJOT Altracs®</b> M6x14	10 Nm (7.4 lbf ft)	<b>Loctite® 243™</b>
Screw, retaining bracket, valve cover, rear	<b>EJOT Altracs®</b> M6x10	10 Nm (7.4 lbf ft)	–
Hose clip, intake flange	M4	1.5 Nm (1.11 lbf ft)	–
Oil nozzle	M5	2 Nm (1.5 lbf ft)	<b>Loctite® 243™</b>
Remaining engine screws	M5	6 Nm (4.4 lbf ft)	–
Screw, bearing retainer	M5	6 Nm (4.4 lbf ft)	<b>Loctite® 243™</b>

Screw, bearing shells retaining bracket	M5	6 Nm (4.4 lbf ft)	Loctite® 243™
Screw, engine oil level viewer	M5	4 Nm (3 lbf ft)	–
Screw, gear sensor	M5	6 Nm (4.4 lbf ft)	Loctite® 243™
Screw, pulse generator	M5	6 Nm (4.4 lbf ft)	Loctite® 243™
Bleeder screw, water pump cover	M6	10 Nm (7.4 lbf ft)	–
Freewheel ring bolt	M6 – 10.9	15 Nm (11.1 lbf ft)	Loctite® 648™
Nut, cylinder head	M6	9 Nm (6.6 lbf ft)	–
Plug, vacuum connection	M6	5 Nm (3.7 lbf ft)	Loctite® 243™
Remaining engine screws	M6	10 Nm (7.4 lbf ft)	–
Screw, camshaft bearing support	M6 – 10.9	10 Nm (7.4 lbf ft)	–
Screw, clutch cover	M6	10 Nm (7.4 lbf ft)	–
Screw, clutch spring	M6	12 Nm (8.9 lbf ft)	–
Screw, coolant connection on cylinder head	M6	8 Nm (5.9 lbf ft)	–
Screw, engine case	M6x60	10 Nm (7.4 lbf ft)	–
Screw, engine case	M6x80	10 Nm (7.4 lbf ft)	–
Screw, engine case	M6x90	10 Nm (7.4 lbf ft)	–
Screw, freewheel holder	M6	10 Nm (7.4 lbf ft)	Loctite® 243™
Screw, locking lever	M6	10 Nm (7.4 lbf ft)	Loctite® 243™
Screw, oil pump cover	M6	10 Nm (7.4 lbf ft)	Loctite® 243™
Screw, shift drum locating	M6	18 Nm (13.3 lbf ft)	Loctite® 243™
Screw, shift lever	M6	15 Nm (11.1 lbf ft)	Loctite® 243™
Screw, starter motor	M6	10 Nm (7.4 lbf ft)	–
Screw, stator	M6	10 Nm (7.4 lbf ft)	Loctite® 243™
Screw, valve cover	M6	10 Nm (7.4 lbf ft)	–

## 23 TECHNICAL DATA



Screw, water pump cover	M6	10 Nm (7.4 lbf ft)	–
Screw, water pump wheel	M6	10 Nm (7.4 lbf ft)	<b>Loctite® 243™</b>
Stud, chain shaft	M6	8 Nm (5.9 lbf ft)	–
Nozzle 100	M6x0.75	4 Nm (3 lbf ft)	<b>Loctite® 243™</b>
Plug, crankshaft retainer	M8	15 Nm (11.1 lbf ft)	–
Screw, camshaft bearing support	M8 – 10.9	Step 1 10 Nm (7.4 lbf ft) Step 2 18 Nm (13.3 lbf ft)	–
Screw, camshaft bearing support	M8 – 10.9	Step 1 8.5 Nm (6.27 lbf ft) Step 2 14.5 Nm (10.7 lbf ft)	Only applies when using: Hex key bit (61229025000)
Screw, engine case	M8	18 Nm (13.3 lbf ft)	–
Screw, heat exchanger	M8	15 Nm (11.1 lbf ft)	–
Screw, timing chain guide rail	M8	15 Nm (11.1 lbf ft)	<b>Loctite® 243™</b>
Stud, exhaust flange	M8	10 Nm (7.4 lbf ft)	–
Timing chain tensioning rail screw	M8	15 Nm (11.1 lbf ft)	<b>Loctite® 243™</b>
Screw, engine bearer	M10	45 Nm (33.2 lbf ft)	–
Oil pressure sensor	M10x1	10 Nm (7.4 lbf ft)	–
Plug, cam lever axis	M10x1	15 Nm (11.1 lbf ft)	–
Plug, clutch lubrication	M10x1	10 Nm (7.4 lbf ft)	–



Screw, conrod bearing	M10x1	Step 1 25 Nm (18.4 lbf ft) Step 2 30 Nm (22.1 lbf ft) Step 3 90°	–
Screw, timing chain tensioner release	M10x1	10 Nm (7.4 lbf ft)	–
Spark plug	M10x1	11 Nm (8.1 lbf ft)	–
Cylinder head screw	M11x1.5	Tightening sequence: Using a crisscross pattern Step 1 15 Nm (11.1 lbf ft) Step 2 30 Nm (22.1 lbf ft) Step 3 90° Step 4 90°	Lubricated with engine oil
Coolant temperature sensor	M12x1.5	12 Nm (8.9 lbf ft)	–
Rotor screw	M12x1.5	115 Nm (84.8 lbf ft)	–
Spark plug	M12x1.5	18 Nm (13.3 lbf ft)	–
Nut of engine sprocket	M20x1.5	100 Nm (73.8 lbf ft)	<b>Loctite® 243™</b>
Oil drain plug	M20x1.5	20 Nm (14.8 lbf ft)	–
Nut, inner clutch hub	M22x1.5	120 Nm (88.5 lbf ft)	<b>Loctite® 243™</b>
Plug, timing-chain tensioner	M24x1.5	25 Nm (18.4 lbf ft)	–
Screw in alternator cover	M24x1.5	8 Nm (5.9 lbf ft)	–
Nut, primary gear	M33LHx1.5	130 Nm (95.9 lbf ft)	<b>Loctite® 243™</b>

## 23.3 Capacities

### 23.3.1 Engine oil

Engine oil	3.60 l (3.8 qt.)	Outside temperature: $\geq 0\text{ }^{\circ}\text{C}$ ( $\geq 32\text{ }^{\circ}\text{F}$ )	Engine oil (SAE 10W/50) (  p. 217)
		Outside temperature: $< 0\text{ }^{\circ}\text{C}$ ( $< 32\text{ }^{\circ}\text{F}$ )	Engine oil (SAE 5W/40) (  p. 217)

### 23.3.2 Coolant

Coolant	2.40 l (2.54 qt.)	Coolant (  p. 216)
---------	-------------------	---

### 23.3.3 Fuel

Fuel reserve, approx.	3.5 l (3.7 qt.)	
Total fuel tank capacity, approx.	23 l (6.1 US gal)	Super unleaded (ROZ 95/RON 95/PON 91) (  p. 218)

## 23.4 Chassis

Frame	Lattice frame made of chrome molybdenum steel tubing, powder-coated
Fork	<b>WP Performance Systems</b> ROMA 4357 upside down
Shock absorber	<b>WP Performance Systems</b> 4618 Emulsion
Suspension travel	
Front	185 mm (7.28 in)
Rear	190 mm (7.48 in)
Brake system	

Front	Double disc brake with radially mounted four-pot brake calipers, floating brake discs
Rear	Single disc brake with dual-piston brake caliper, floating brake disc
Brake discs - diameter	
Front	320 mm (12.6 in)
Rear	267 mm (10.51 in)
Brake discs - wear limit	
Front	4 mm (0.16 in)
Rear	4.5 mm (0.177 in)
Tire air pressure, solo/with passenger/full payload	
Front: with cold tires	2.4 bar (35 psi)
Rear: with cold tires	2.9 bar (42 psi)
Secondary drive ratio	17:42
Chain	5/8 x 5/16" (525) X-ring
Steering head angle	64°
Wheelbase	1,560±15 mm (61.42±0.59 in)
Seat height, unloaded	850 mm (33.46 in)
Ground clearance, unloaded	220 mm (8.66 in)
Weight without fuel, approx.	212 kg (467 lb.)
Maximum permissible front axle load	175 kg (386 lb.)
Maximum permissible rear axle load	300 kg (661 lb.)
Maximum permissible total weight	450 kg (992 lb.)

## 23.5 Electrical system

Battery	YTZ14S	Battery voltage: 12 V Nominal capacity: 11.2 Ah maintenance-free
Fuse	58011109110	10 A
Fuse	58011109115	15 A
Fuse	58011109125	25 A
Fuse	58011109130	30 A
Low beam	H11/socket PGJ19-2	12 V 55 W
High beam	H11/socket PGJ19-2	12 V 55 W
Parking light	LED	
Instrument lights and indicator lamps	LED	
Turn signal	RY10W / socket BAU15s	12 V 10 W
Tail light	LED	
Brake light	LED	
License plate lamp	LED	

## 23.6 Tires

Front tires	Rear tires
<b>110/80 R 19 M/C 59V TL</b> Metzeler Tourance NEXT	<b>150/70 R 17 M/C 69V TL</b> Metzeler Tourance NEXT
The tires specified represent one of the possible series production tires. Additional information is available in the Service section under: <a href="http://www.ktm.com">http://www.ktm.com</a>	

## 23.7 Fork

Fork part number	05.18.60.08	
Fork	<b>WP Performance Systems</b> ROMA 4357 upside down	
Spring length with preload spacer(s)	460 mm (18.11 in)	
Spring rate		
Medium (standard)	6 N/mm (34 lb/in)	
Fork length	886.5 mm (34.902 in)	
Air chamber length	47 mm (1.85 in)	
Fork oil per fork leg	570 ml (19.27 fl. oz.)	Fork oil (SAE 4) (48601166S1) (🔊 p. 218)

## 23.8 Shock absorber

Shock absorber article number	01.18.90.08	
Shock absorber	<b>WP Performance Systems</b> 4618 Emulsion	
Rebound damping		
Standard	12 clicks	
Spring preload		

Standard	2 turns
Spring preload	
Standard	10 mm (0.39 in)
Spring rate	
Medium (standard)	170 N/mm (971 lb/in)
Spring length	205 mm (8.07 in)
Static sag	25 mm (0.98 in)
Fitted length	402 mm (15.83 in)
Shock absorber fluid (📖 p. 218)	SAE 2.5

## 23.9 Chassis tightening torques

Screw, combination switch, left	M4	2 Nm (1.5 lbf ft)	–
Screw, side stand switch	M4	2 Nm (1.5 lbf ft)	–
Rear fairing screw	M5x12	3.5 Nm (2.58 lbf ft)	–
Rear fairing screw	M5x17	3.5 Nm (2.58 lbf ft)	–
Remaining nuts, chassis	M5	5 Nm (3.7 lbf ft)	–
Remaining screws, chassis	M5	5 Nm (3.7 lbf ft)	–
Screw brake line holder on frame	M5	2 Nm (1.5 lbf ft)	–
Screw, brake line holder on swingarm	M5	5 Nm (3.7 lbf ft)	–
Screw, cable channel	M5	5 Nm (3.7 lbf ft)	–
Screw, cable guide, wheel speed sensor, rear	M5	3 Nm (2.2 lbf ft)	–
Screw, chain sliding guard	M5	5 Nm (3.7 lbf ft)	–
Screw, combination switch, right	M5	3.5 Nm (2.58 lbf ft)	–

Screw, cover part	M5	3.5 Nm (2.58 lbf ft)	–
Screw, filler cap	M5	3 Nm (2.2 lbf ft)	–
Screw, foot brake lever stub	M5	6 Nm (4.4 lbf ft)	<b>Loctite® 243™</b>
Screw, fuel level sensor	M5	3 Nm (2.2 lbf ft)	–
Screw, heat guard on main silencer	M5	4 Nm (3 lbf ft)	–
Screw, wind shield	M5	3.5 Nm (2.58 lbf ft)	–
Ground fitting on frame	M6	6 Nm (4.4 lbf ft)	–
Nut, ABS unit fixation	M6	8 Nm (5.9 lbf ft)	–
Remaining chassis nuts	M6	10 Nm (7.4 lbf ft)	–
Remaining chassis screws	M6	10 Nm (7.4 lbf ft)	–
Screw, ball joint of push rod on foot brake cylinder	M6	10 Nm (7.4 lbf ft)	<b>Loctite® 243™</b>
Screw, battery terminal	M6	4.5 Nm (3.32 lbf ft)	–
Screw, brake line holder on bottom triple clamp	M6	10 Nm (7.4 lbf ft)	–
Screw, cable channel	M6	5 Nm (3.7 lbf ft)	–
Screw, chain guide	M6	5 Nm (3.7 lbf ft)	–
Screw, clutch assembly	M6	5 Nm (3.7 lbf ft)	–
Screw, cooler retaining bracket	M6	7 Nm (5.2 lbf ft)	–
Screw, cover part	M6	6 Nm (4.4 lbf ft)	–
Screw, engine guard	M6	10 Nm (7.4 lbf ft)	–
Screw, exhaust clamp	M6	8 Nm (5.9 lbf ft)	–
Screw, foot brake cylinder	M6	10 Nm (7.4 lbf ft)	<b>Loctite® 243™</b>
Screw, front brake disc	M6	14 Nm (10.3 lbf ft)	<b>Loctite® 243™</b>
Screw, fuel pump	M6	6 Nm (4.4 lbf ft)	–

## 23 TECHNICAL DATA

Screw, fuel tank	M6	10 Nm (7.4 lbf ft)	–
Screw, fuel tap	M6	6 Nm (4.4 lbf ft)	–
Screw, headlight	M6	5 Nm (3.7 lbf ft)	–
Screw, lower rear part	M6	6 Nm (4.4 lbf ft)	–
Screw, magnetic holder on side stand	M6	6 Nm (4.4 lbf ft)	<b>Loctite® 243™</b>
Screw, rear brake disc	M6	14 Nm (10.3 lbf ft)	<b>Loctite® 243™</b>
Screw, retaining bracket, angle sensor	M6	10 Nm (7.4 lbf ft)	–
Screw, voltage regulator	M6	6 Nm (4.4 lbf ft)	–
Screw, wheel speed sensor, front	M6	10 Nm (7.4 lbf ft)	–
Screw, wheel speed sensor, rear	M6	10 Nm (7.4 lbf ft)	–
Angle valve	M8	4 Nm (3 lbf ft)	–
Hand guard screw	M8	15 Nm (11.1 lbf ft)	–
Remaining chassis nuts	M8	25 Nm (18.4 lbf ft)	–
Remaining chassis screws	M8	25 Nm (18.4 lbf ft)	–
Screw, bottom triple clamp	M8	12 Nm (8.9 lbf ft)	–
Screw, exhaust clamp	M8	25 Nm (18.4 lbf ft)	–
Screw, foot brake lever	M8	25 Nm (18.4 lbf ft)	<b>Loctite® 243™</b>
Screw, fork stub	M8	15 Nm (11.1 lbf ft)	–
Screw, front footrest bracket	M8	25 Nm (18.4 lbf ft)	<b>Loctite® 243™</b>
Screw, handlebar clamp	M8	20 Nm (14.8 lbf ft)	–
Screw, ignition lock	M8	25 Nm (18.4 lbf ft)	<b>Loctite® 243™</b>
Screw, rear footrest bracket	M8	25 Nm (18.4 lbf ft)	<b>Loctite® 243™</b>
Screw, steering damper	M8	25 Nm (18.4 lbf ft)	<b>Loctite® 243™</b>
Screw, steering damper clamp	M8	12 Nm (8.9 lbf ft)	–
Screw, steering stem	M8	20 Nm (14.8 lbf ft)	–



## 23 TECHNICAL DATA

Screw, suitcase hook	M8	20 Nm (14.8 lbf ft)	Loctite® 243™
Screw, top triple clamp	M8	15 Nm (11.1 lbf ft)	–
Remaining chassis nuts	M10	45 Nm (33.2 lbf ft)	–
Remaining chassis screws	M10	45 Nm (33.2 lbf ft)	–
Screw, front brake caliper	M10	45 Nm (33.2 lbf ft)	Loctite® 243™
Screw, handlebar support	M10	40 Nm (29.5 lbf ft)	Loctite® 243™
Screw, side stand	M10	35 Nm (25.8 lbf ft)	Loctite® 243™
Screw, side stand bracket	M10	45 Nm (33.2 lbf ft)	Loctite® 243™
Banjo bolt, brake line	M10x1	25 Nm (18.4 lbf ft)	–
Nut, rear sprocket screw	M10x1.25	50 Nm (36.9 lbf ft)	Loctite® 243™
Lambda sensor	M12x1.25	25 Nm (18.4 lbf ft)	–
Screw, bottom shock absorber	M14x1.5	80 Nm (59 lbf ft)	Thread greased
Screw, top shock absorber	M14x1.5	80 Nm (59 lbf ft)	Thread greased
Nut, swingarm pivot	M19x1.5	130 Nm (95.9 lbf ft)	Thread greased
Screw, steering head, top	M22x1.5	18 Nm (13.3 lbf ft)	–
Nut, rear wheel spindle	M25x1.5	90 Nm (66.4 lbf ft)	Thread greased
Screw, front wheel spindle	M25x1.5	45 Nm (33.2 lbf ft)	Thread greased

## Brake fluid DOT 4 / DOT 5.1

### Standard/classification

- DOT

### Guideline

- Use only brake fluid that complies with the specified standard (see specifications on the container) and that exhibits the corresponding properties.

### Recommended supplier

#### Castrol

- **RESPONSE BRAKE FLUID SUPER DOT 4**

#### Motorex®

- **Brake Fluid DOT 5.1**

## Coolant

### Guideline

- Only use high-grade, silicate-free coolant with corrosion inhibitor additive for aluminum motors. Low grade and unsuitable antifreeze causes corrosion, deposits and frothing.
- Do not use pure water as only coolant is able to meet the requirements needed in terms of corrosion protection and lubrication properties.
- Only use coolant that complies with the requirements stated (see specifications on the container) and that has the relevant properties.

Antifreeze protection to at least	-25 °C (-13 °F)
-----------------------------------	-----------------

The mixture ratio must be adjusted to the necessary antifreeze protection. Use distilled water if the coolant needs to be diluted.

The use of premixed coolant is recommended.

Observe the coolant manufacturer specifications for antifreeze protection, dilution and miscibility (compatibility) with other coolants.

## Recommended supplier

Motorex®

- COOLANT M3.0

## Engine oil (SAE 10W/50)

### Standard/classification

- JASO T903 MA (📖 p. 221)
- SAE (📖 p. 221) (SAE 10W/50)

### Guideline

- Use only engine oils that comply with the specified standards (see specifications on the container) and that possess the corresponding properties.

Fully synthetic engine oil

## Recommended supplier

Motorex®

- Power Synt 4T

## Engine oil (SAE 5W/40)

### Standard/classification

- JASO T903 MA (📖 p. 221)
- SAE (📖 p. 221) (SAE 5W/40)

### Guideline

- Use only engine oils that comply with the specified standards (see specifications on the container) and that possess the corresponding properties.

Synthetic engine oil

## Recommended supplier

Motorex®

- Power Synt 4T

## Fork oil (SAE 4) (48601166S1)

### Standard/classification

- SAE (📖 p. 221) (SAE 4)

### Guideline

- Use only oils that comply with the specified standards (see specifications on the container) and that exhibit the corresponding properties.

## Shock absorber fluid (SAE 2.5) (50180751S1)

### Standard/classification

- SAE (📖 p. 221) (SAE 2.5)

### Guideline

- Use only oils that comply with the specified standards (see specifications on the container) and that exhibit the corresponding properties.

## Super unleaded (ROZ 95/RON 95/PON 91)

### Standard/classification

- DIN EN 228 (ROZ 95/RON 95/PON 91)

### Guideline

- Only use unleaded super fuel that matches or is equivalent to the specified fuel grade.
- Fuel with an ethanol content of up to 10 % (E10 fuel) is safe to use.



### Info

Do **not** use fuel containing methanol (e. g. M15, M85, M100) or more than 10 % ethanol (e. g. E15, E25, E85, E100).

---

## Chain cleaner

Recommended supplier

Motorex®

- Chain Clean

## Chain lube for road use

Guideline

Recommended supplier

Motorex®

- Chainlube Road

## Fuel additive

Recommended supplier

Motorex®

- Fuel Stabilizer

## Long-life grease

Recommended supplier

Motorex®

- Bike Grease 2000

## Motorcycle cleaner

Recommended supplier

Motorex®

- Moto Clean

## Perfect Finish and high gloss polish for paints

Recommended supplier

Motorex®

- Moto Polish & Shine

## Preserving materials for paints, metal and rubber

Recommended supplier

Motorex®

- Moto Protect

## Special cleaner for glossy and matte paint finishes, metal and plastic surfaces

Recommended supplier

Motorex®

- Quick Cleaner

## Universal oil spray

Recommended supplier

Motorex®

- Joker 440 Synthetic

## JASO T903 MA

Different technical development directions required a separate specification for 4-stroke motorcycles – the **JASO T903 MA** standard. Earlier, engine oils from the automobile industry were used for 4-stroke motorcycles because there was no separate motorcycle specification.

Whereas long service intervals are demanded for automobile engines, the focus for motorcycle engines is on high performance at high engine speeds.

In most motorcycle engines, the transmission and the clutch are lubricated with the same oil.

The **JASO MA** standard meets these special requirements.

## SAE

The SAE viscosity classes were defined by the Society of Automotive Engineers and are used for classifying oils according to their viscosity. The viscosity describes only one property of oil and says nothing about quality.

## 27 INDEX OF SPECIAL TERMS

ABS	ABS	Safety system that prevents locking of the wheels when driving straight ahead without the influence of lateral forces
ATIR	Automatic Turn Indicator Reset	Software, which automatically switches the indicator off according to a time or travel distance counter
DRL	Daytime Running Light	Light, which enhances the visibility of the vehicle during the day but is not focused, and in contrast to low beam does not illuminate the road surface
TC	Traction Control	Auxiliary function of the motor control that reduces engine torque with spinning rear wheel





## 28 LIST OF ABBREVIATIONS

Art. no.	Article number
ca.	circa
cf.	compare
e.g.	for example
etc.	et cetera
i.a.	inter alia
no.	number
poss.	possibly





## 29.1 Red symbols

Red symbols indicate an error condition that requires immediate intervention.

	The immobilizer indicator lamp lights up or flashes red – Status or error message for immobilizer/alarm system.
	The oil pressure warning lamp lights up red – Engine oil pressure is too low.

## 29.2 Yellow and orange symbols

Yellow and orange symbols indicate an error condition that requires prompt intervention. Active driving aids are also represented by yellow or orange symbols.



	The general warning lamp lights up yellow – An operating safety (warning) message was detected. This is also shown on the matrix display.
	The engine warning lamp lights up/flashes yellow – The engine control unit has detected a fault.
	The ABS lamp lights up/flashes yellow – ABS is not active. The ABS lamp also lights up if an error is detected.
	The TC lamp lights up/flashes yellow – Traction control is not enabled or is currently intervening. The TC lamp also lights up if an error is detected.

## 29.3 Green and blue symbols

Green and blue symbols reflect information.

	The high beam indicator lamp lights up blue – The high beam is switched on.
---	---

## 29 LIST OF SYMBOLS

	The left turn signal lamp flashes green with a steady rhythmic flash – The left turn signal is switched on.
	The idle indicator lamp lights up green – The transmission is in idle.
	The right turn signal lamp flashes green with a steady rhythmic flash – The right turn signal is switched on.

## A

<b>ABS</b> . . . . .	129
<b>Accessories</b> . . . . .	15
<b>Antilock brake system</b> . . . . .	129
<b>Auxiliary substances</b> . . . . .	15

## B

<b>Battery</b>	
installing . . . . .	157
recharging . . . . .	159
removing . . . . .	155
<b>Brake discs</b>	
checking . . . . .	131
<b>Brake fluid</b>	
front brake, adding . . . . .	133
rear brake, adding . . . . .	136
<b>Brake fluid level</b>	
front brake, checking . . . . .	132
rear brake, checking . . . . .	135
<b>Brake linings</b>	
front brake, checking . . . . .	134
rear brake, checking . . . . .	138
<b>Brake system</b> . . . . .	129-139
<b>Brakes</b> . . . . .	84
<b>Brakes, applying</b> . . . . .	84

## C

<b>Capacity</b>	
coolant . . . . .	208
engine oil . . . . .	191, 208
fuel . . . . .	90, 208
<b>Chain</b>	
checking . . . . .	106
checking for dirt . . . . .	102
cleaning . . . . .	102
<b>Chain tension</b>	
adjusting . . . . .	104
checking . . . . .	103
<b>Chassis number</b> . . . . .	22
<b>Clutch</b>	
fluid level, checking/correcting . . . . .	109
<b>Clutch lever</b> . . . . .	<b>26</b>
basic position, adjusting . . . . .	66
<b>Combination instrument</b> . . . . .	<b>43-54, 56-62</b>
"ABS" . . . . .	53
activation and test . . . . .	43
"Clock/Date" . . . . .	60
"Distance" . . . . .	58
"Drive Mod" . . . . .	53, 185
"DRL" . . . . .	61
"Favorites" . . . . .	49
"Fuel Cons" . . . . .	59
"general info" . . . . .	50

"Heat Grip" . . . . .	61	<b>Emergency OFF switch</b> . . . . .	31
"Heating" menu . . . . .	52	<b>Engine</b>	
indicator lamps . . . . .	45	running in . . . . .	75
"Language" . . . . .	57	<b>Engine guard</b>	
matrix display . . . . .	44	installing . . . . .	128
menu overview . . . . .	56	removing . . . . .	128
message on the matrix display . . . . .	46	<b>Engine number</b> . . . . .	24
"MTC" . . . . .	53	<b>Engine oil</b>	
overview . . . . .	43	adding . . . . .	192
"Pressure" . . . . .	59	changing . . . . .	188
segment display . . . . .	44	<b>Engine oil level</b>	
service display . . . . .	48	checking . . . . .	187
"Set Favorites" . . . . .	51	<b>Engine sprocket</b>	
"Settings" . . . . .	51	checking . . . . .	106
shift warning light . . . . .	47	<b>Environment</b> . . . . .	13
"Shift Light" . . . . .	60	<b>F</b>	
"Temp" . . . . .	58	<b>Figures</b> . . . . .	16
"Trip 1" . . . . .	49	<b>Filler cap</b>	
"Trip 2" . . . . .	50	closing . . . . .	36
"Warning" . . . . .	52	opening . . . . .	34
<b>Combination switch</b> . . . . .	27	<b>Foot brake lever</b> . . . . .	42
overview . . . . .	27	basic position, adjusting . . . . .	72
<b>Coolant level</b>		<b>Footrests</b>	
checking in the compensating tank . . . . .	181	adjusting . . . . .	68
correcting in the compensating tank . . . . .	182	<b>Fork</b>	
<b>Customer service</b> . . . . .	16	dust boots, cleaning . . . . .	122
<b>E</b>			
<b>Electric starter button</b> . . . . .	31		

<b>Fork part number</b> .....	24
<b>Front fender, front</b>	
installing .....	121
removing .....	121
<b>Front wheel</b>	
installing .....	142
removing .....	140
<b>Fuel cocks</b> .....	37
<b>Fuel level display</b> .....	45
<b>Fuses</b>	
in fuse box, changing .....	165
<b>G</b>	
<b>Grab handles</b> .....	39
<b>H</b>	
<b>Hand brake lever</b> .....	26
basic position, adjusting .....	67
<b>Handlebar position</b> .....	63
adjusting .....	63
<b>Hazard warning flasher</b> .....	28
<b>Hazard warning flasher switch</b> .....	28
<b>Headlight</b>	
daytime running light .....	154
headlight range, adjusting .....	175
<b>Headlight adjustment</b>	
checking .....	174

<b>Headlight mask with headlight</b>	
installing .....	169
removing .....	167
<b>High beam bulb</b>	
changing .....	171
<b>Horn button</b> .....	30
<b>I</b>	
<b>Ignition key</b>	
activating/deactivating .....	176
<b>Ignition lock</b> .....	32
<b>Immobilizer</b> .....	32
<b>Intended use</b> .....	10
<b>K</b>	
<b>Key number</b> .....	23
<b>L</b>	
<b>Light switch</b> .....	28
<b>Low beam bulb</b>	
changing .....	170
<b>Luggage</b> .....	76
<b>Luggage rack plate</b> .....	40
<b>M</b>	
<b>Main fuse</b>	
changing .....	163
<b>Mask spoiler</b>	
installing .....	118

removing	116
<b>Matrix display</b>	
menu	49
<b>Misuse</b>	10
<b>Motorcycle</b>	
cleaning	195
lifting with front lifting gear	97
raising with the rear lifting gear	96
raising with work stand (inserted)	99
removing from the work stand (inserted)	100
removing the rear from the lifting gear	96
taking from the front lifting gear	98
<b>O</b>	
<b>Oil filter</b>	
changing	188
<b>Oil screens</b>	
cleaning	188
<b>Operating substances</b>	15
<b>Owner's Manual</b>	14
<b>P</b>	
<b>Parking</b>	86
<b>Passenger footrest</b>	40
<b>Preparing for use</b>	
advice on first use	74
after storage	200
checks and maintenance measures when preparing for use	78

<b>Protective clothing</b>	13
<b>R</b>	
<b>Rear hub rubber dampers</b>	
checking	149
<b>Rear sprocket</b>	
checking	106
<b>Rear wheel</b>	
installing	147
removing	145
<b>Refueling</b>	
fuel	89
<b>Rider footrests</b>	67
<b>Riding</b>	<b>80</b>
starting off	80
<b>S</b>	
<b>Safe operation</b>	12
<b>Seat</b>	
mounting	101
removing	101
<b>Seat lock</b>	39
<b>Service</b>	16
<b>Service schedule</b>	91-93
<b>Shift lever</b>	<b>41</b>
basic position, adjusting	71
basic position, checking	70

<b>Shifting</b> .....	80
<b>Shock absorber</b>	
rebound damping, adjusting .....	94
spring preload, adjusting .....	94
<b>Shock absorber article number</b> .....	25
<b>Side cover, front</b>	
installing .....	114
removing .....	113
<b>Side stand</b> .....	42
<b>Spare parts</b> .....	15
<b>Starting</b> .....	79
<b>Steering</b>	
locking .....	33
unlocking .....	34
<b>Steering head bearing play</b>	
checking .....	110
<b>Steering lock</b> .....	32
<b>Stopping</b> .....	86
<b>Storage</b> .....	199
<b>Storage compartment</b>	
closing .....	38
opening .....	38
<b>Suspension setting</b> .....	94-95
<b>Switch</b>	
on the left side of the handlebar .....	27
on the right side of the handlebar .....	31

<b>T</b>	
<b>Tank cover</b>	
installing .....	125
removing .....	123
<b>TC</b> .....	185
<b>Technical data</b>	
capacities .....	208
chassis .....	208
chassis tightening torques .....	212
electrical system .....	210
engine .....	203-215
engine tightening torques .....	204
fork .....	211
shock absorber .....	211
tires .....	211
<b>Throttle grip</b> .....	27
<b>Tire air pressure</b>	
checking .....	152
<b>Tire condition</b>	
checking .....	151
<b>Traction control</b> .....	185
<b>Transport</b> .....	88
<b>Triple clamp cover, bottom</b>	
installing .....	112
removing .....	111
<b>Troubleshooting</b> .....	201-202



<b>Turn signal bulb</b>	
changing	173
<b>Turn signal switch</b>	29
<b>Type label</b>	22
<b>U</b>	
<b>Use definition</b>	10
<b>V</b>	
<b>Vehicle</b>	
loading	76
<b>View of vehicle</b>	
front left	18
rear right side	20
<b>W</b>	
<b>Warranty</b>	15
<b>Wind shield</b>	
adjusting	65
installing	127
removing	127
<b>Winter operation</b>	
checks and maintenance steps	197
<b>Work rules</b>	13

**READY TO RACE**  
» [www.ktm.com](http://www.ktm.com)



3213545en

10/2016

**KTM Sportmotorcycle GmbH**  
3230 Mattighofen/Austria  
<http://www.ktm.com>



Photo: Mitterbauer/KTM