

250 SX-F 250 XC-F

Art. no. 3213576en



KTM

Perform the work described in these setup instructions before the vehicle is delivered to the customer.

Read the setup instructions in their entirety before beginning work.

These setup instructions were written to correspond to the latest state of this series. We reserve the right to make changes in the interest of technical advancement without at the same time updating this manual.

We shall not provide a description of general workshop methods. Likewise, safety rules that apply in a workshop are not specified here. It is assumed that the work will be performed by a fully trained mechanic.

All specifications are non-binding. KTM Sportmotorcycle GmbH specifically reserves the right to modify or delete technical specifications, prices, colors, forms, materials, services, designs, equipment, etc., without prior notice and without specifying reasons, to adapt these to local conditions, as well as to stop production of a particular model without prior notice. KTM accepts no liability for delivery options, deviations from illustrations and descriptions, misprints, and other errors. The models portrayed partly contain special equipment that does not belong to the regular scope of supply.

© 2016 KTM Sportmotorcycle GmbH, Mattighofen Austria

All rights reserved

Reproduction, even in part, as well as copying of all kinds, is permitted only with the express written permission of the copyright owner.



ISO 9001(12 100 6061)

According to the international quality management standard ISO 9001, KTM uses quality assurance processes that lead to the maximum possible quality of the products.

Issued by: TÜV Management Service

REG.NO. 12 100 6061

KTM Sportmotorcycle GmbH
5230 Mattighofen, Austria

This document is valid for the following models:

250 SX-F EU (F8101Q5)

250 SX-F US (F8175Q5)

250 XC-F US (F8175Q0)



1.1 Symbols used

The meaning of specific symbols is described below.



Indicates an expected reaction (e.g. of a work step or a function).



Indicates an unexpected reaction (e.g. of a work step or a function).



Indicates a page reference (more information is provided on the specified page).



Indicates information with more details or tips.



Indicates the result of a testing step.



Denotes a voltage measurement.



Denotes a current measurement.



Denotes a resistance measurement.

1.2 Formats used

The typographical formats used in this document are explained below.

Proprietary name	Identifies a proprietary name.
Name®	Identifies a protected name.
Brand™	Identifies a trademark.
<u>Underlined terms</u>	Refer to technical details of the vehicle or indicate technical terms, which are explained in the glossary.

2.1 Unpacking and setting up the vehicle

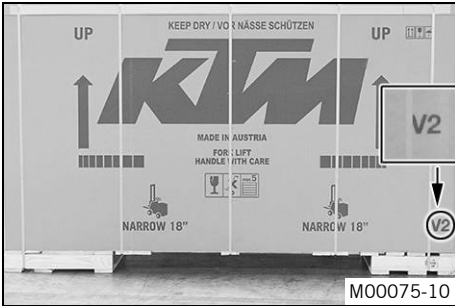

Package 2

- Remove the box and the plastic packaging.

i Info
To avoid damaging the motorcycle during the setup, leave the protective film on the vehicle until you have finished.

- Remove the separate enclosure and unpack it. Check that the scope of supply is complete on the basis of the enclosed packing list.
- Have a lift stand available.

Lift stand (78129955100)

- Carefully loosen and remove the tension belt of the footrest mount.

i Info
An assistant prevents the motorcycle from falling over.

- Together with an assistant, take the vehicle off the palette.
- Position the vehicle on a lift stand.
- Check the vehicle for transport damage.

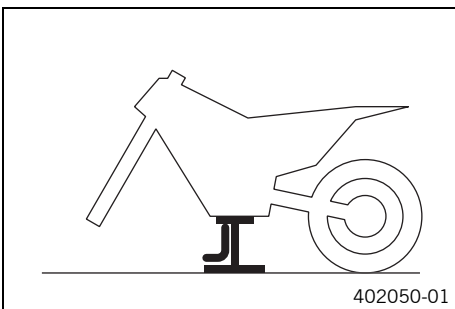

Package 12

- Remove the box and the plastic packaging.

i Info
An assistant prevents the motorcycle from falling over.
To avoid damaging the motorcycle during the setup, leave the protective film on the vehicle until you have finished.

- Remove the separate enclosure and unpack it. Check that the scope of supply is complete on the basis of the enclosed packing list.
- Have a lift stand available.

Lift stand (78129955100)

- Together with an assistant, take the vehicle off the palette.
- Position the vehicle on a lift stand.
- Check the vehicle for transport damage.

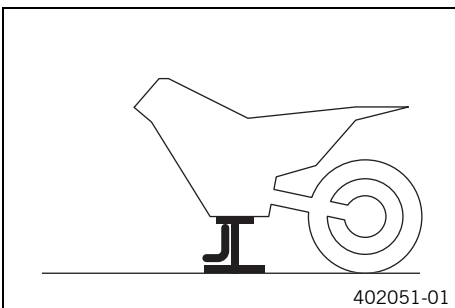
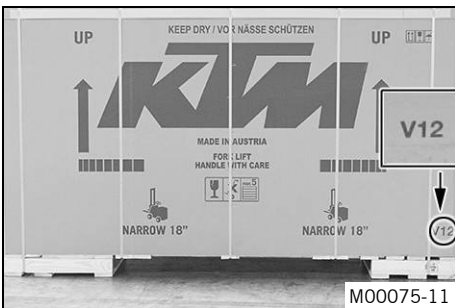

- Remove the cardboard from around the shock absorber.
- Position the angle lever and linkage lever.
- Mount and tighten screw cap ①.

Guideline

Nut, frame to linkage lever	M14x1.5	80 Nm (59 lbf ft)
-----------------------------	---------	-------------------

- Mount and tighten screw ②.

Guideline

Screw, bottom shock absorber	M10	60 Nm (44.3 lbf ft)	Loctite® 2701™
------------------------------	-----	---------------------	----------------

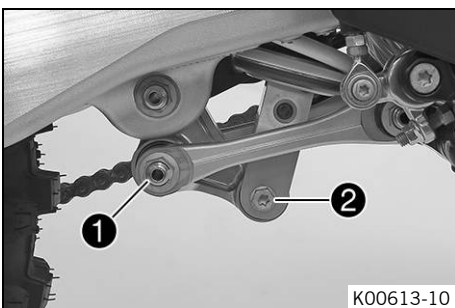

i Info
Raise the wheel slightly to be able to mount the screw more easily.



K00686-01

- Route the clutch line with the clutch master cylinder toward the front between the upper and lower triple clamps.

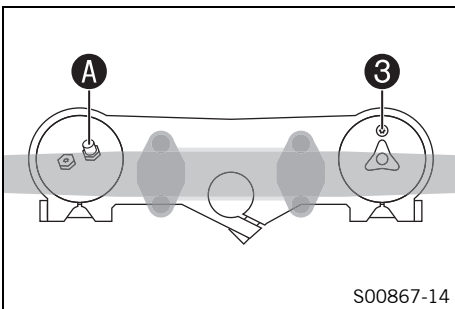

S00867-14

- Position the fork legs and tighten the screws of the triple clamp.

Guideline

Screw, top triple clamp	M8	17 Nm (12.5 lbf ft)
Screw, bottom triple clamp	M8	12 Nm (8.9 lbf ft)

- ✓ The air release screw **3** of the right fork leg is positioned to the front.
- ✓ The left fork leg valve **A** is positioned approx. 20 ° further forward.

i Info
Grooves are milled into the side of the upper end of the fork legs. The second milled groove (from the top) must be flush with the top edge of the upper triple clamp.
The air suspension is located in the left fork leg. The pressure and rebound damping is located in the right fork leg.
Position the bleeder screw of the right fork leg and the valve of the left fork leg facing forward.

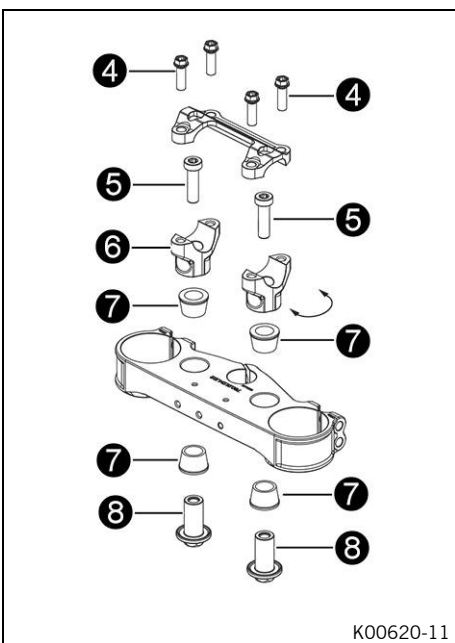

K00620-11

- Remove screws **4**. Remove the handlebar clamp. Remove the handlebar and lay it to one side.

i Info
Cover the components to protect them against damage.
Do not kink the cables and lines.

- Remove screws **5**. Take off handlebar supports **6**.
- Position rubber bushings **7** and push through nuts **8** from below.
- Place the handlebar supports in the required position.

i Info
The handlebar supports are longer and higher on one side.
Position the left and right handlebar supports evenly.

- Mount and tighten screws **5**.

Guideline

Screw, handlebar support	M10	40 Nm (29.5 lbf ft)	Loctite® 243™
--------------------------	-----	---------------------	---------------

- Position the handlebar.

i Info
Make sure the cables and wiring are positioned correctly.

- Position the handlebar clamp.
- Mount screws ④, but do not tighten yet.
- First bolt the handlebar support with screws ④ onto the longer, higher side of the handlebar supports so that both parts touch.
- Tighten screws ④ evenly.

Guideline

Screw, handlebar clamp	M8	20 Nm (14.8 lbf ft)
------------------------	----	------------------------

- Position the controls on the right half of the handlebar.



- Position the controls on the left half of the handlebar.

Guideline

Screw, fixed grip	M4	5 Nm (3.7 lbf ft)	Loctite® 243™
-------------------	----	----------------------	---------------

- Install the front fender. (📖 p. 10)
- Install the front wheel. (📖 p. 9)



- Position the malfunction indicator lamp using holder ⑨. Mount and tighten screw.

Guideline

Remaining screws, chassis	M6	10 Nm (7.4 lbf ft)
---------------------------	----	--------------------

- Connect plug-in connector ⑩.
- Connect plug-in connector ⑪.
- Correctly mount the fuel tank breather.

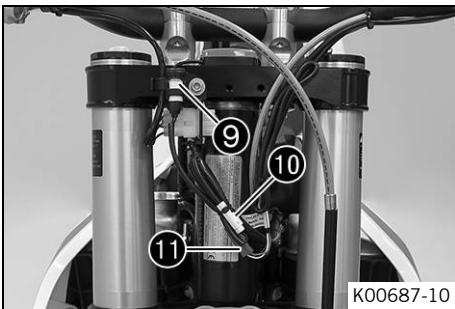

- Mount the handlebar cushion.



Left and right footrest (All SX-F models)

- Position the new footrest and pin.



Info

Only insert the pins to the extent that the spring can still be mounted.

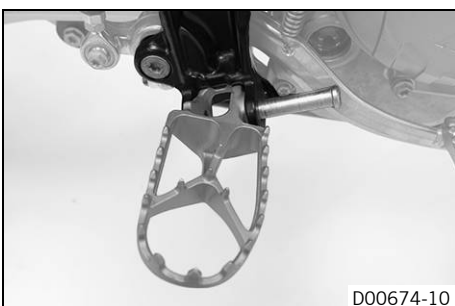

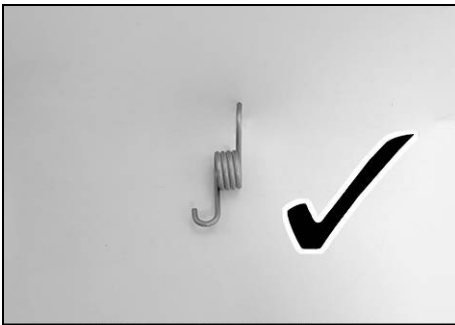

- Position spring as shown.
- ✓ Spring **B** engages in area **C**.

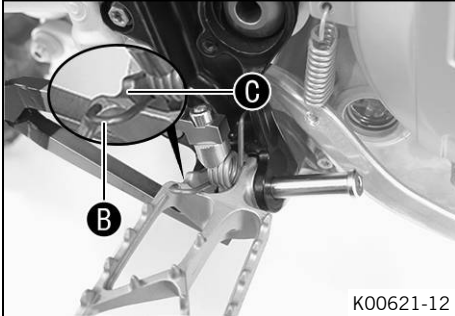

K00621-12

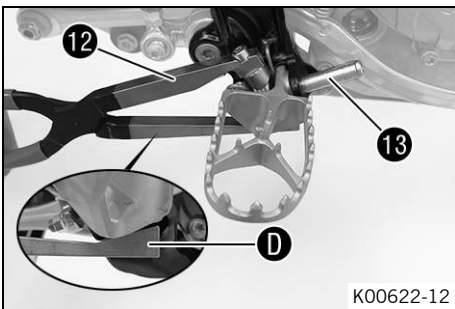

K00622-12

- Press the spring with special tool **12**.

Pliers for footrest spring (79029083000)

- ✓ The special tool is applied to area **D** on the footrest.
- Mount pin **13**.

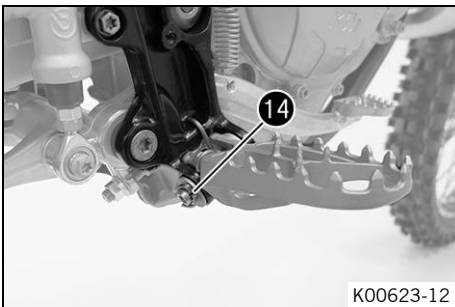

K00623-12

- Mount the washer and split pin **14**.
- Repeat these steps on the opposite side.

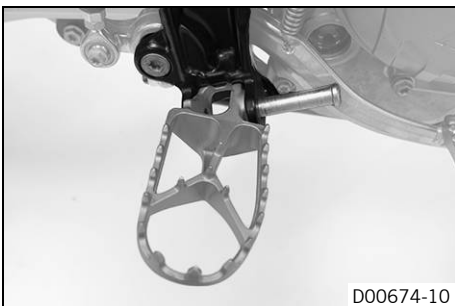

D00674-10

Right footrest (XC-F US)

- Position the right footrest and pin.



Info

Only insert the pins to the extent that the spring can still be mounted.

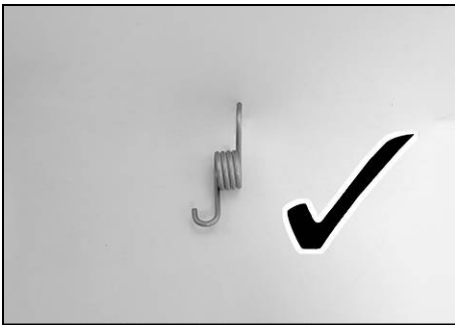

- Position spring as shown.
- ✓ Spring **B** engages in area **C**.

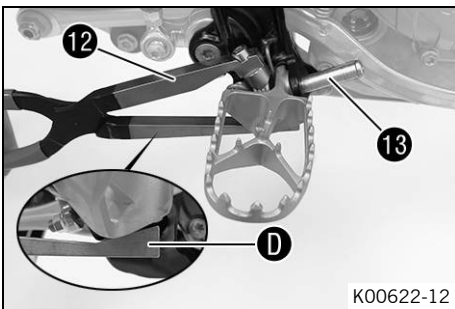
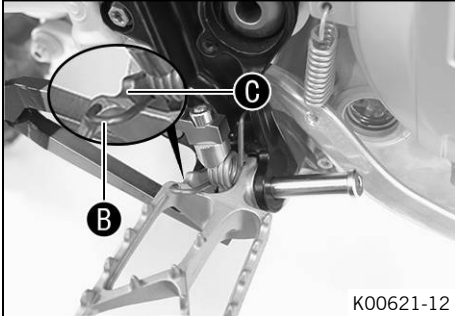

- Press the spring with special tool **12**.

Pliers for footrest spring (79029083000)

- ✓ The special tool is applied to area **D** on the footrest.
- Mount pin **13**.

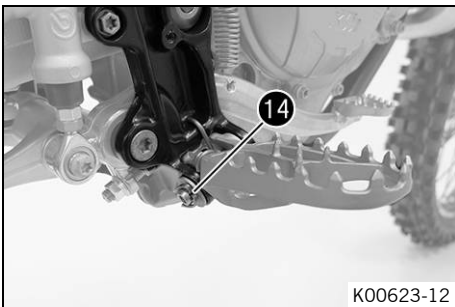

- Mount the washer and split pin **14**.

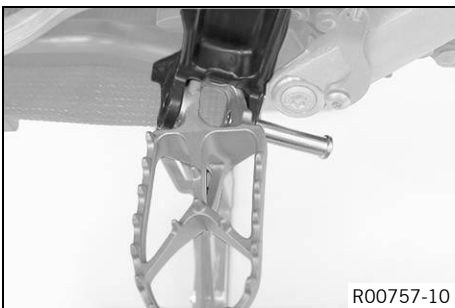

Left footrest (XC-F US)

- Position the left footrest and pin.



Info

Only insert the pins to the extent that the spring can still be mounted.

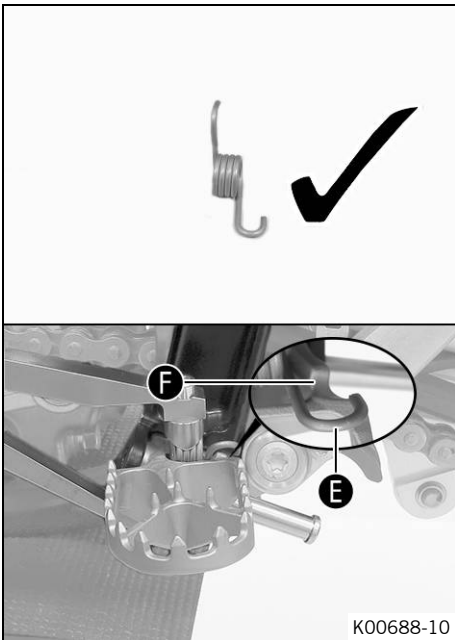

- Position spring as shown.
- ✓ Spring **E** engages in area **F**.

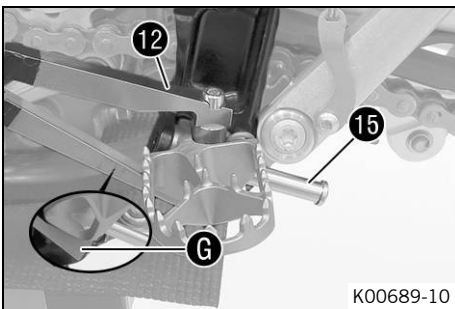

- Press the spring with special tool **12**.
- Pliers for footrest spring (79029083000)
- ✓ The special tool is applied to area **G** on the footrest.
 - Mount pin **15**.

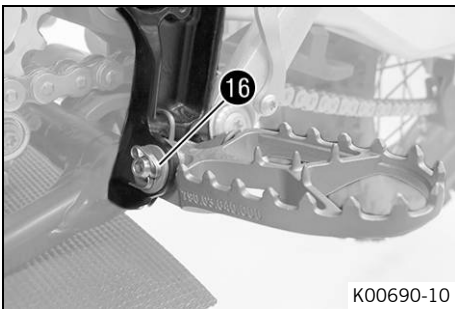

- Mount the washer and split pin **16**.
- Install the start number plate. (📖 p. 10)
- Recharge the battery. (📖 p. 12)
- Install the battery. (📖 p. 12)
- Unpack and mount the **KTM PowerParts** included in the delivery (optional).



Info

Read the accompanying **KTM PowerParts** fitting instructions.

- Apply the label included in the delivery (optional).
 - Refuel. (📖 p. 14)
 - Position all controls in their exact positions on the handlebar. Tighten all screws.
- Guideline

Screw, fixed grip	M4	5 Nm (3.7 lbf ft)	Loctite® 243™
-------------------	----	----------------------	----------------------

- Prepare the vehicle according to the specifications in the **KTM Dealer.net** for hand-over to the customer.

3.1 Raising the motorcycle with a lift stand

Note

Danger of damage The parked vehicle can roll away or fall over.

- Park the vehicle on a firm and level surface.

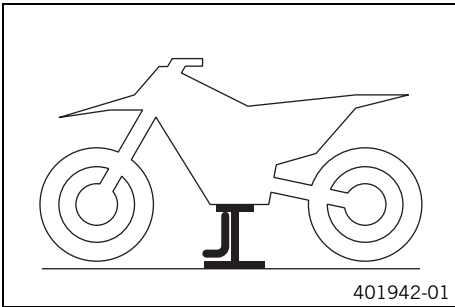

- Raise the motorcycle at the frame underneath the engine.

Lift stand (78129955100)

- ✓ Neither wheel is in contact with the ground.
- Secure the motorcycle against falling over.

3.2 Removing the motorcycle from the lift stand

Note

Danger of damage The parked vehicle can roll away or fall over.

- Park the vehicle on a firm and level surface.

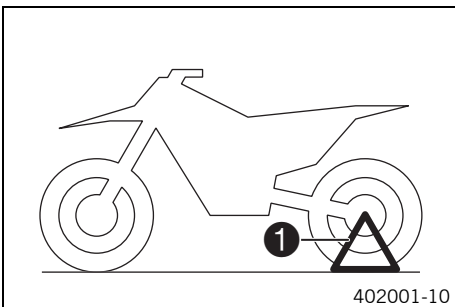

(All SX-F models)

- Remove the motorcycle from the lift stand.
- Remove the lift stand.
- To park the motorcycle, insert plug-in stand 1 into the left side of the wheel spindle.



Info

Remove the plug-in stand before starting on a trip.

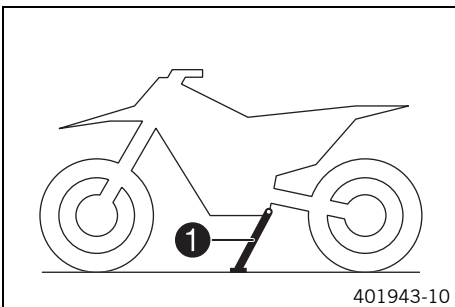

(XC-F US)

- Remove the motorcycle from the lift stand.
- Remove the lift stand.
- To park the motorcycle, press side stand 1 to the ground with your foot and lean the motorcycle on it.



Info

When you are riding, the side stand must be folded up and secured with the rubber band.

3.3 Installing the front wheel



Warning

Danger of accidents Oil or grease on the brake discs reduces the braking effect.

- Always keep the brake discs free of oil and grease.
- Clean the brake discs with brake cleaner when necessary.

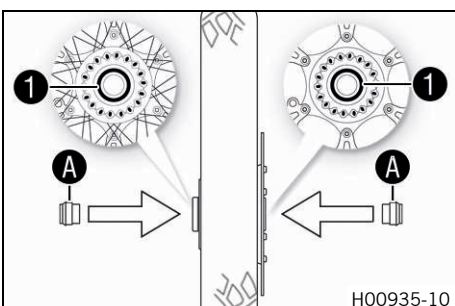

- Check the wheel bearing for damage and wear.
 - » If the wheel bearing is damaged or worn:
 - Change the front wheel bearing.
- Clean and grease shaft seal rings 1 and contact surface A of the spacers.

Long-life grease (🔧 p. 19)

- Insert the spacers.

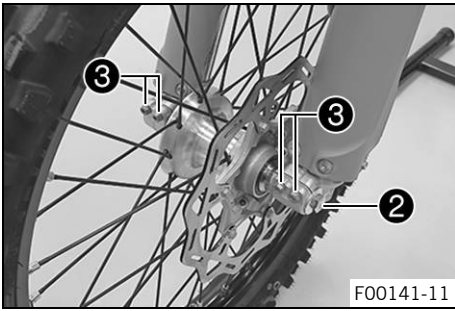

- Position the front wheel and insert the wheel spindle.
 - ✓ The brake linings are correctly positioned.
- Mount and tighten screw ②.

Guideline

Screw, front wheel spindle	M20x1.5	35 Nm (25.8 lbf ft)
----------------------------	---------	------------------------

- Operate the hand brake lever several times until the brake linings are seated correctly against the brake disc.
- Remove the motorcycle from the lift stand. (🗨️ p. 9)
- Operate the front brake and compress the fork a few times firmly.
 - ✓ The fork legs straighten.
- Tighten screws ③.

Guideline

Screw, fork stub	M8	15 Nm (11.1 lbf ft)
------------------	----	------------------------

3.4 Installing the front fender

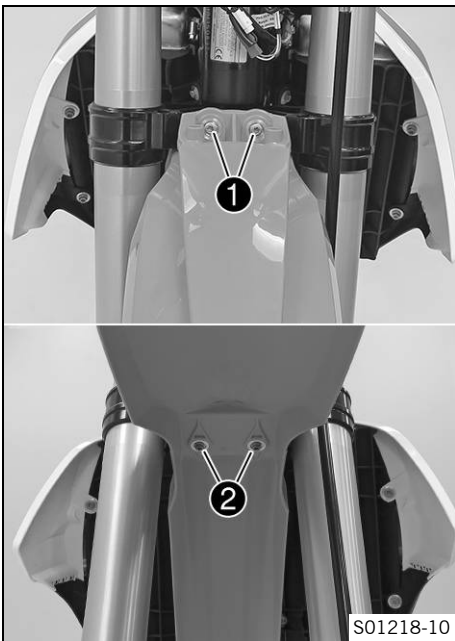

Main work

- Position the front fender. Mount and tighten screws ① and ②.

Guideline

Remaining screws, chassis	M6	10 Nm (7.4 lbf ft)
---------------------------	----	--------------------

Finishing work

- Install the start number plate. (🗨️ p. 10)

3.5 Installing the start number plate

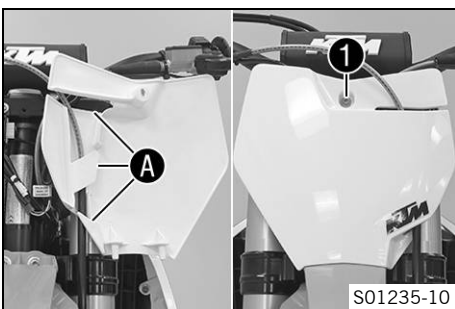

- Position the brake line in holders A on the start number plate.
- Position the start number plate. Mount and tighten screw ①.
 - ✓ The holding lugs engage in the fender.

3.6 Removing the seat

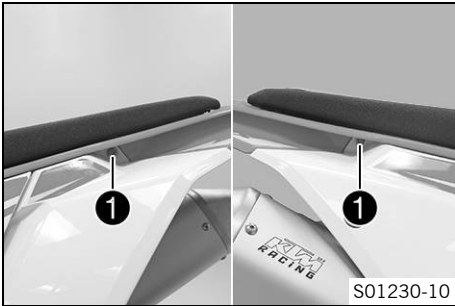

- Remove screws ❶.

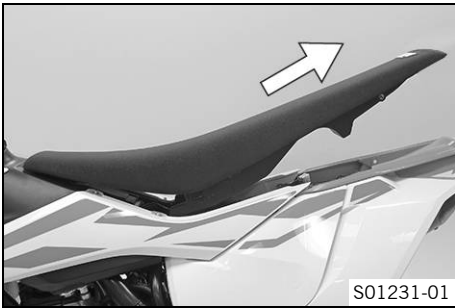

- Raise the rear of the seat, pull the seat back, and lift it off.

3.7 Mounting the seat

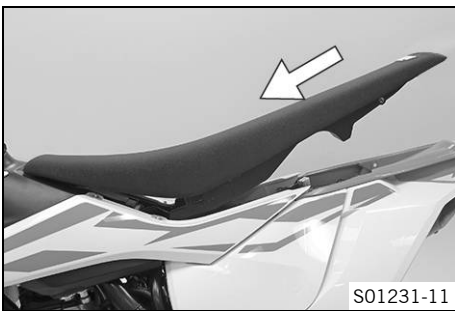

- Mount the front of the seat on the collar bushing of the fuel tank, lower the seat at the rear, and push the seat forward.

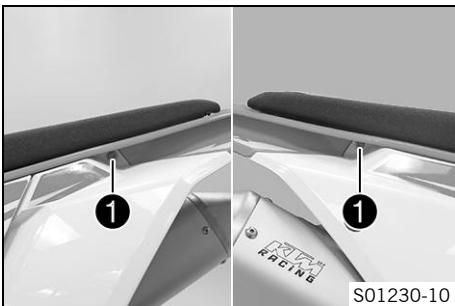

- Mount and tighten screws ❶.

Guideline

Remaining screws, chassis	M6	10 Nm (7.4 lbf ft)
---------------------------	----	--------------------

3.8 Installing the battery

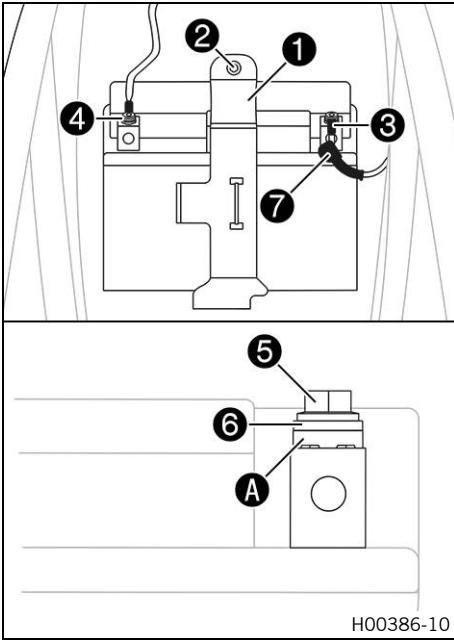

Main work

- Insert the battery into the battery compartment with the terminals facing forward and secure with holding bracket **1**.

(All SX-F models)

Battery (C22S)

(XC-F US)

Battery (HJTZ5S-FP)

- Mount and tighten screw **2**.

Guideline

Remaining screws, chassis	M6	10 Nm (7.4 lbf ft)
---------------------------	----	--------------------

- Connect positive cable **3** to the battery.

Guideline

Screw, battery terminal	M5	2.5 Nm (1.84 lbf ft)
-------------------------	----	-------------------------

- Connect negative cable **4** to the battery.

Guideline

Screw, battery terminal	M5	2.5 Nm (1.84 lbf ft)
-------------------------	----	-------------------------

Contact disks **A** must be mounted under screws **5** and cable sockets **6** with the claws toward the battery terminal.

- Slide positive terminal cover **7** over the positive terminal.

Finishing work

- Mount the seat. (📖 p. 11)

3.9 Recharging the battery



Warning

Risk of injury Batteries contain harmful substances.

- Keep batteries out of the reach of children.
- Keep sparks and open flames away from the batteries.
- Only charge batteries in well-ventilated rooms.
- Maintain a minimum clearance from inflammable materials when charging batteries.
Minimum clearance 1 m (3 ft)
- Do not charge deeply discharged batteries if charge is already below the minimum voltage.
Minimum voltage before the start of the charge 9 V
- Dispose of batteries with less than the minimum voltage correctly.



Warning

Environmental hazard Batteries contain environmentally-hazardous materials.

- Do not dispose of batteries as household waste.
- Dispose of batteries at a collection point for used batteries.



Warning

Environmental hazard Hazardous substances cause environmental damage.

- Dispose of oils, grease, filters, fuel, cleaning agents, brake fluid, etc., correctly and in compliance with the applicable regulations.

i Info

Even when there is no load on the battery, it discharges steadily. The charging level and the method of charging are very important for the service life of the battery. Rapid recharging with a high charging current shortens the service life of the battery. If the charging current, charging voltage, or charging time are exceeded, the battery will be destroyed. If the battery is depleted by repeated starting, the battery must be charged immediately. If the battery is left in a discharged state for an extended period, it will become over-discharged and sulfated, destroying the battery. The battery is maintenance-free.

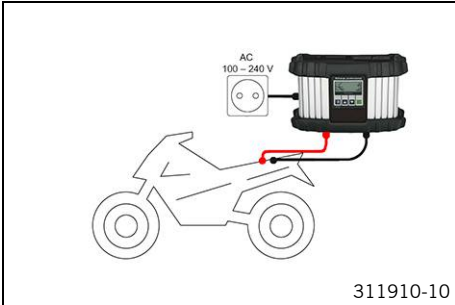

Preparatory work

- Remove the seat. (📖 p. 11)

Main work

- Connect the battery charger to the battery. Set the battery charger.

Alternative 1

Battery charger **XCharge-professional** EU (00029095050)

Alternative 2

Battery charger **XCharge-professional** US (00029095051)

Alternative 3

Battery charger **XCharge-professional** GB (00029095052)

Alternative 4

Battery charger **XCharge-professional** CH (00029095053)

i Info

Follow the instructions of the charger and the manual.

- Disconnect the battery charger after charging the battery.

Guideline

The charging current, charging voltage, and charging time must not be exceeded.	
Charge the battery regularly when the motorcycle is not in use	3 months

Finishing work

- Mount the seat. (📖 p. 11)

3.10 Opening the filler cap

! Danger

Fire hazard Fuel is highly flammable.

The fuel in the fuel tank expands when warm and can escape if overfilled.

- Do not refuel the vehicle in the vicinity of open flames or lit cigarettes.
- Switch off the engine for refueling.
- Make sure that no fuel is spilled; particularly not on hot parts of the vehicle.
- If any fuel is spilled, wipe it off immediately.
- Observe the specifications for refueling.

! Warning

Danger of poisoning Fuel is poisonous and a health hazard.

- Avoid skin, eye and clothing contact with fuel.
- Immediately consult a doctor if you swallow fuel.
- Do not inhale fuel vapors.
- In case of skin contact, rinse the affected area with plenty of water.
- Rinse the eyes thoroughly with water, and consult a doctor in case of fuel contact with the eyes.
- Change your clothing in case of fuel spills on them.
- Keep fuels correctly in a suitable canister, and out of the reach of children.



Warning

Environmental hazard Improper handling of fuel is a danger to the environment.

- Do not allow fuel to enter the groundwater, the soil, or the sewage system.

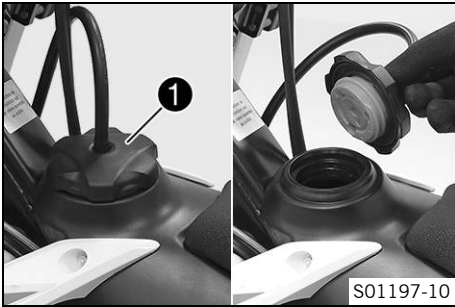

(All SX-F models)

- Turn filler cap ① counterclockwise and lift it off.

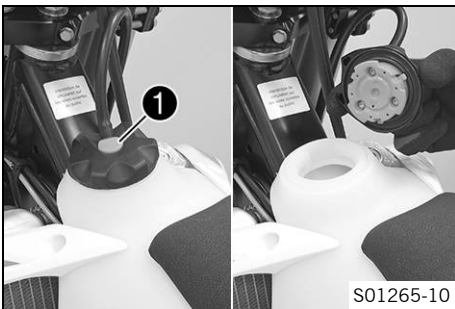

(XC-F US)

- Press release button ①, turn the filler cap counterclockwise, and lift it off.

3.11 Closing the filler cap



(All SX-F models)

- Mount filler cap ① and turn it clockwise until the fuel tank is tightly closed.



Info

Route fuel tank breather hose ② without kinks.

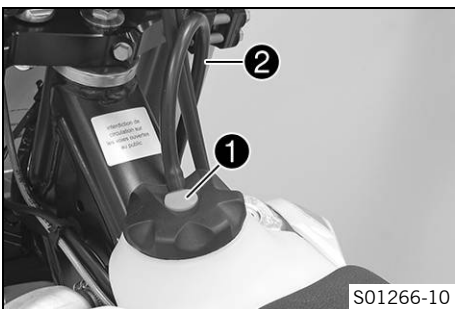

(XC-F US)

- Replace the filler cap and turn clockwise until release button ① locks in place.



Info

Route fuel tank breather hose ② without kinks.

3.12 Refueling



Danger

Fire hazard Fuel is highly flammable.

The fuel in the fuel tank expands when warm and can escape if overfilled.

- Do not refuel the vehicle in the vicinity of open flames or lit cigarettes.
- Switch off the engine for refueling.
- Make sure that no fuel is spilled; particularly not on hot parts of the vehicle.
- If any fuel is spilled, wipe it off immediately.
- Observe the specifications for refueling.



Warning

Danger of poisoning Fuel is poisonous and a health hazard.

- Avoid skin, eye and clothing contact with fuel.
- Immediately consult a doctor if you swallow fuel.
- Do not inhale fuel vapors.
- In case of skin contact, rinse the affected area with plenty of water.
- Rinse the eyes thoroughly with water, and consult a doctor in case of fuel contact with the eyes.
- Change your clothing in case of fuel spills on them.

Note

Material damage Inadequate fuel quality causes the fuel filter to quickly become clogged.

In some countries and regions, the available fuel quality and cleanliness may not be sufficient. This will result in problems with the fuel system.

- Refuel only with clean fuel that meets the specified standards.



Warning

Environmental hazard Improper handling of fuel is a danger to the environment.

- Do not allow fuel to enter the groundwater, the soil, or the sewage system.



- Switch off the engine.
- Open the filler cap. (📖 p. 13)
- Fill the fuel tank with fuel up to measurement **A**.

Guideline

Measurement of A	35 mm (1.38 in)	
Total fuel tank capacity, approx. (All SX-F models)	7 l (1.8 US gal)	Super unleaded (ROZ 95/RON 95/PON 91) (📖 p. 18)
Total fuel tank capacity, approx. (XC-F US)	8.5 l (2.25 US gal)	Super unleaded (ROZ 95/RON 95/PON 91) (📖 p. 18)

- Close the filler cap. (📖 p. 14)

4.1 Chassis tightening torques

Screw, air filter box cover	EJOT PT® K60x20-Z	3 Nm (2.2 lbf ft)	–
Screw, combination switch	EJOT PT® K50x18	3 Nm (2.2 lbf ft)	–
Screw, intake air temperature sensor	EJOT DELTA PT® 45x12-Z	1 Nm (0.7 lbf ft)	–
Screw, pressure regulator	EJOT PT® K60x25-Z	3 Nm (2.2 lbf ft)	–
Screw, fixed grip	M4	5 Nm (3.7 lbf ft)	Loctite® 243™
Screw, service hour counter	M4	1 Nm (0.7 lbf ft)	–
Spoke nipple, front wheel	M4.5	6 Nm (4.4 lbf ft)	–
Spoke nipple, rear wheel	M4.5	6 Nm (4.4 lbf ft)	–
Remaining nuts, chassis	M5	5 Nm (3.7 lbf ft)	–
Remaining screws, chassis	M5	5 Nm (3.7 lbf ft)	–
Screw, battery terminal	M5	2.5 Nm (1.84 lbf ft)	–
Screw, frame protector	M5	3 Nm (2.2 lbf ft)	–
Screw, shock absorber adjusting ring	M5	5 Nm (3.7 lbf ft)	–
Nut, electric starter cable connection	M6	4 Nm (3 lbf ft)	–
Remaining nuts, chassis	M6	10 Nm (7.4 lbf ft)	–
Remaining screws, chassis	M6	10 Nm (7.4 lbf ft)	–
Screw, ball joint of push rod on foot brake cylinder	M6	10 Nm (7.4 lbf ft)	Loctite® 243™
Screw, chain sliding guard	M6	6 Nm (4.4 lbf ft)	Loctite® 243™
Screw, front brake disc	M6	14 Nm (10.3 lbf ft)	Loctite® 243™
Screw, rear brake disc	M6	14 Nm (10.3 lbf ft)	Loctite® 243™
Screw, throttle grip	M6	5 Nm (3.7 lbf ft)	–
Fuel connection on fuel tank	M8	10 Nm (7.4 lbf ft)	–
Nut, foot brake lever stop	M8	20 Nm (14.8 lbf ft)	–
Nut, rear sprocket screw	M8	35 Nm (25.8 lbf ft)	Loctite® 2701™
Nut, rim lock	M8	12 Nm (8.9 lbf ft)	–
Remaining nuts, chassis	M8	25 Nm (18.4 lbf ft)	–
Remaining screws, chassis	M8	25 Nm (18.4 lbf ft)	–
Screw side stand attachment (XC-F US)	M8	35 Nm (25.8 lbf ft)	Loctite® 2701™
Screw, bottom triple clamp	M8	12 Nm (8.9 lbf ft)	–
Screw, chain sliding piece	M8	15 Nm (11.1 lbf ft)	–
Screw, engine brace	M8	25 Nm (18.4 lbf ft)	Loctite® 243™
Screw, fork stub	M8	15 Nm (11.1 lbf ft)	–
Screw, front brake caliper	M8	25 Nm (18.4 lbf ft)	Loctite® 243™
Screw, handlebar clamp	M8	20 Nm (14.8 lbf ft)	–
Screw, subframe	M8	35 Nm (25.8 lbf ft)	Loctite® 2701™
Screw, top steering stem	M8	20 Nm (14.8 lbf ft)	Loctite® 243™
Screw, top triple clamp	M8	17 Nm (12.5 lbf ft)	–
Engine carrying screw	M10	60 Nm (44.3 lbf ft)	–
Remaining nuts, chassis	M10	45 Nm (33.2 lbf ft)	–
Remaining screws, chassis	M10	45 Nm (33.2 lbf ft)	–
Screw, bottom shock absorber	M10	60 Nm (44.3 lbf ft)	Loctite® 2701™
Screw, handlebar support	M10	40 Nm (29.5 lbf ft)	Loctite® 243™
Screw, top shock absorber	M10	60 Nm (44.3 lbf ft)	Loctite® 2701™
Nut, fuel pump	M12	15 Nm (11.1 lbf ft)	–
Nut, frame to linkage lever	M14x1.5	80 Nm (59 lbf ft)	–
Nut, linkage lever on swingarm	M14x1.5	80 Nm (59 lbf ft)	–
Nut, linkage lever to angle lever	M14x1.5	80 Nm (59 lbf ft)	–
Nut, swingarm pivot	M16x1.5	100 Nm (73.8 lbf ft)	–
Screw, front wheel spindle	M20x1.5	35 Nm (25.8 lbf ft)	–

4 TECHNICAL DATA

Screw, top steering head	M20x1.5	12 Nm (8.9 lbf ft)	–
Screw-in nozzles, cooling system	M20x1.5	12 Nm (8.9 lbf ft)	Loctite® 243™
Nut, rear wheel spindle	M25x1.5	80 Nm (59 lbf ft)	–

Super unleaded (ROZ 95/RON 95/PON 91)

Standard/classification

- DIN EN 228 (ROZ 95/RON 95/PON 91)

Guideline

- Only use unleaded super fuel that matches or is equivalent to the specified fuel grade.
- Fuel with an ethanol content of up to 10 % (E10 fuel) is safe to use.



Info

Do **not** use fuel containing methanol (e. g. M15, M85, M100) or more than 10 % ethanol (e. g. E15, E25, E85, E100).

Long-life grease

Recommended supplier

Motorex®

– Bike Grease 2000



3213576en

10/2016

