

250 SX

250 XC

300 XC

Art. no. 3213637en



**KTM**



# DEAR KTM CUSTOMER

Congratulations on your decision to purchase a KTM motorcycle. You are now the owner of a state-of-the-art sports motorcycle that will give you enormous pleasure if you service and maintain it properly.

We hope you enjoy your new vehicle!

Enter the serial numbers of your vehicle below.

|                          |                |
|--------------------------|----------------|
| Chassis number (📖 p. 12) | Dealer's stamp |
| Engine number (📖 p. 12)  |                |

The Owner's Manual contained the latest information for this model series at the time of going to print. However, minor differences due to further developments in design cannot be ruled out completely.

All specifications are non-binding. KTM Sportmotorcycle GmbH specifically reserves the right to modify or delete technical specifications, prices, colors, forms, materials, services, designs, equipment, etc., without prior notice and without specifying reasons, to adapt these to local conditions, as well as to stop production of a particular model without prior notice. KTM accepts no liability for delivery options, deviations from illustrations and descriptions, misprints, and other errors. The models portrayed partly contain special equipment that does not belong to the regular scope of supply.

© 2017 KTM Sportmotorcycle GmbH, Mattighofen Austria  
All rights reserved

Reproduction, even in part, as well as copying of all kinds, is permitted only with the express written permission of the copyright owner.



ISO 9001(12 100 6061)

According to the international quality management standard ISO 9001, KTM uses quality assurance processes that lead to the maximum possible quality of the products.

Issued by: TÜV Management Service

REG.NO. 12 100 6061

KTM Sportmotorcycle GmbH  
5230 Mattighofen, Austria

This document is valid for the following models:

250 SX EU (F6301R0)

250 SX US (F6375R0)

































250 XC US (F6375R5)

300 XC US (F6475R5)



# TABLE OF CONTENTS

|      |  |    |       |   |    |
|------|--|----|-------|---|----|
| 1    | MEANS OF REPRESENTATION .....                                    | 5  | 8     | RIDING INSTRUCTIONS .....   | 25 |
| 1.1  | Symbols used .....   | 5  | 8.1   | Checks and maintenance measures when preparing for use.....             | 25 |
| 1.2  | Formats used.....  | 5  | 8.2   | Starting.....   | 25 |
| 2    | SAFETY ADVICE.....   | 6  | 8.3   | Starting off.....   | 26 |
| 2.1  | Use definition – intended use.....                               | 6  | 8.4   | Shifting, riding .....  | 26 |
| 2.2  | Misuse.....  | 6  | 8.5   | Applying the brakes.....  | 27 |
| 2.3  | Safety advice.....   | 6  | 8.6   | Stopping, parking.....  | 27 |
| 2.4  | Degrees of risk and symbols .....                                | 6  | 8.7   | Transport .....   | 28 |
| 2.5  | Tampering warning.....   | 6  | 8.8   | Refueling .....   | 28 |
| 2.6  | Safe operation .....   | 7  | 9     | SERVICE SCHEDULE .....  | 30 |
| 2.7  | Protective clothing .....  | 7  | 9.1   | Additional information.....   | 30 |
| 2.8  | Work rules.....  | 7  | 9.2   | Required work .....   | 30 |
| 2.9  | Environment.....   | 7  | 9.3   | Recommended work .....  | 31 |
| 2.10 | Owner's Manual .....   | 8  | 10    | TUNING THE CHASSIS .....  | 32 |
| 3    | IMPORTANT NOTES.....   | 9  | 10.1  | Checking the basic chassis setting with the rider's weight.....         | 32 |
| 3.1  | Manufacturer and implied warranty.....                           | 9  | 10.2  | Air suspension AER 48.....  | 32 |
| 3.2  | Operating and auxiliary substances .....                         | 9  | 10.3  | Compression damping of the shock absorber.....                          | 32 |
| 3.3  | Spare parts, accessories .....                                   | 9  | 10.4  | Adjusting the low-speed compression damping of the shock absorber ..... | 33 |
| 3.4  | Service .....  | 9  | 10.5  | Adjusting the high-speed compression damping of the shock absorber..... | 33 |
| 3.5  | Figures .....  | 9  | 10.6  | Adjusting the rebound damping of the shock absorber.....                | 34 |
| 3.6  | Customer service.....  | 9  | 10.7  | Measuring the rear wheel dimension unloaded.....                        | 35 |
| 4    | VIEW OF VEHICLE .....  | 10 | 10.8  | Checking the static sag of the shock absorber....                       | 35 |
| 4.1  | View of vehicle, front left (example) .....                      | 10 | 10.9  | Checking the riding sag of the shock absorber....                       | 36 |
| 4.2  | View of vehicle, rear right (example) .....                      | 11 | 10.10 | Adjusting the spring pretension of the shock absorber 🛠.....            | 36 |
| 5    | SERIAL NUMBERS .....   | 12 | 10.11 | Adjusting the riding sag 🛠.....   | 37 |
| 5.1  | Chassis number .....   | 12 | 10.12 | Checking the basic setting of the fork .....                            | 37 |
| 5.2  | Type label .....   | 12 | 10.13 | Adjusting the fork air pressure.....                                    | 38 |
| 5.3  | Engine number .....  | 12 | 10.14 | Adjusting the compression damping of the fork .....                     | 39 |
| 5.4  | Fork part number .....   | 12 | 10.15 | Adjusting the rebound damping of the fork.....                          | 39 |
| 5.5  | Shock absorber article number.....                               | 12 | 10.16 | Handlebar position.....   | 40 |
| 6    | CONTROLS.....  | 13 | 10.17 | Adjusting the handlebar position 🛠.....                                 | 40 |
| 6.1  | Clutch lever.....  | 13 | 11    | SERVICE WORK ON THE CHASSIS.....  | 42 |
| 6.2  | Hand brake lever.....  | 13 | 11.1  | Raising the motorcycle with a lift stand.....                           | 42 |
| 6.3  | Throttle grip .....  | 13 | 11.2  | Removing the motorcycle from the lift stand.....                        | 42 |
| 6.4  | Kill switch.....   | 13 | 11.3  | Bleeding the fork legs.....   | 43 |
| 6.5  | Electric starter button (All XC models) .....                    | 13 | 11.4  | Cleaning the dust boots of the fork legs.....                           | 43 |
| 6.6  | Opening the filler cap.....                                      | 14 | 11.5  | Removing the fork legs 🛠.....   | 43 |
| 6.7  | Closing the filler cap .....                                     | 14 | 11.6  | Installing the fork legs 🛠.....   | 44 |
| 6.8  | Fuel tap (All SX models).....                                    | 15 | 11.7  | Removing the fork protector .....                                       | 44 |
| 6.9  | Fuel tap (All XC models).....                                    | 15 | 11.8  | Installing the fork protector.....                                      | 45 |
| 6.10 | Choke.....   | 16 | 11.9  | Removing the lower triple clamp 🛠.....                                  | 45 |
| 6.11 | Shift lever .....  | 16 | 11.10 | Installing the lower triple clamp 🛠.....                                | 46 |
| 6.12 | Kick starter .....   | 17 | 11.11 | Checking the play of the steering head bearing .....                    | 47 |
| 6.13 | Foot brake lever .....   | 17 | 11.12 | Adjusting the steering head bearing play 🛠.....                         | 48 |
| 6.14 | Plug-in stand (All SX models).....                               | 17 | 11.13 | Greasing the steering head bearing 🛠.....                               | 48 |
| 6.15 | Side stand (All XC models).....                                  | 17 | 11.14 | Removing the start number plate.....                                    | 49 |
| 6.16 | Service hour counter .....                                       | 18 | 11.15 | Installing the start number plate.....                                  | 49 |
| 7    | PREPARING FOR USE.....   | 19 | 11.16 | Removing the front fender .....   | 49 |
| 7.1  | Advice on first use .....  | 19 | 11.17 | Installing the front fender .....                                       | 49 |
| 7.2  | Running in the engine .....                                      | 20 | 11.18 | Removing the shock absorber 🛠.....                                      | 50 |
| 7.3  | Preparing the vehicle for difficult riding conditions .....      | 20 | 11.19 | Installing the shock absorber 🛠.....                                    | 51 |
| 7.4  | Preparing for rides on dry sand.....                             | 21 | 11.20 | Removing the seat .....   | 52 |
| 7.5  | Preparing for rides on wet sand .....                            | 22 | 11.21 | Mounting the seat .....   | 53 |
| 7.6  | Preparing for rides on wet and muddy surfaces.....               | 23 | 11.22 | Removing the air filter box cover .....                                 | 53 |
| 7.7  | Preparations for riding at high temperatures and low speeds..... | 23 |       |   |    |
| 7.8  | Preparing for rides at low temperature or in snow.....           | 24 |       |   |    |

|       |  |    |        |  |     |
|-------|--|----|--------|--|-----|
| 11.23 | Installing the air filter box cover .....  | 53 | 16     | TUNING THE ENGINE .....  | 88  |
| 11.24 | Removing the air filter  .....                                    | 54 | 16.1   | Checking the play in the throttle cable .....  | 88  |
| 11.25 | Cleaning the air filter and air filter box  .....                 | 54 | 16.2   | Adjusting the play in the throttle cable  .....           | 88  |
| 11.26 | Installing the air filter  .....                                  | 55 | 16.3   | Carburetor setting .....   | 89  |
| 11.27 | Securing the air filter box cover  .....                          | 55 | 16.4   | Carburetor – idle .....  | 91  |
| 11.28 | Sealing the air filter box  .....                                 | 55 | 16.5   | Carburetor – adjusting the idle speed  .....              | 91  |
| 11.29 | Removing the main silencer .....   | 56 | 16.6   | Plug-in connector of ignition timing map adjustment .....  | 92  |
| 11.30 | Installing the main silencer .....   | 56 | 16.7   | Changing the ignition timing map .....   | 92  |
| 11.31 | Changing the glass fiber yarn filling in the main silencer  ..... | 56 | 16.8   | Checking the basic position of the shift lever .....   | 92  |
| 11.32 | Removing the fuel tank  .....                                     | 57 | 16.9   | Adjusting the basic position of the shift lever  .....     | 93  |
| 11.33 | Installing the fuel tank  .....                                   | 58 | 16.10  | Engine characteristic – auxiliary spring .....   | 93  |
| 11.34 | Checking the chain for dirt .....  | 59 | 16.11  | Engine characteristic – setting the auxiliary spring  ..... | 93  |
| 11.35 | Cleaning the chain .....   | 60 | 17     | SERVICE WORK ON THE ENGINE .....   | 96  |
| 11.36 | Checking the chain tension .....   | 60 | 17.1   | Emptying the carburetor float chamber  .....              | 96  |
| 11.37 | Adjusting the chain tension .....  | 61 | 17.2   | Checking the gear oil level .....  | 97  |
| 11.38 | Checking the chain, rear sprocket, engine sprocket and chain guide .....   | 61 | 17.3   | Changing the gear oil  .....                              | 97  |
| 11.39 | Checking the frame  .....   | 63 | 17.4   | Adding gear oil  .....                                    | 98  |
| 11.40 | Checking the swingarm  .....                                      | 63 | 18     | CLEANING, CARE .....   | 99  |
| 11.41 | Checking the throttle cable routing .....  | 63 | 18.1   | Cleaning the motorcycle .....  | 99  |
| 11.42 | Checking the rubber grip .....   | 64 | 19     | STORAGE .....  | 100 |
| 11.43 | Adjusting basic position of clutch lever .....   | 64 | 19.1   | Storage .....  | 100 |
| 11.44 | Checking/correcting the fluid level of the hydraulic clutch .....  | 65 | 19.2   | Preparing for use after storage .....  | 101 |
| 11.45 | Changing the hydraulic clutch fluid  .....                        | 65 | 20     | TROUBLESHOOTING .....  | 102 |
| 12    | BRAKE SYSTEM .....   | 67 | 21     | TECHNICAL DATA .....   | 104 |
| 12.1  | Checking the free travel of the hand brake lever .....   | 67 | 21.1   | Engine .....   | 104 |
| 12.2  | Adjusting the basic position of the hand brake lever .....   | 67 | 21.1.1 | All SX models .....  | 104 |
| 12.3  | Checking the brake discs .....   | 67 | 21.1.2 | 250 XC US .....  | 104 |
| 12.4  | Checking the front brake fluid level .....   | 68 | 21.1.3 | 300 XC US .....  | 105 |
| 12.5  | Adding front brake fluid  .....                                 | 68 | 21.2   | Engine tightening torques .....  | 105 |
| 12.6  | Checking the front brake linings .....   | 69 | 21.2.1 | All SX models .....  | 105 |
| 12.7  | Changing the front brake linings  .....                         | 69 | 21.2.2 | All XC models .....  | 106 |
| 12.8  | Checking the free travel of foot brake lever .....   | 71 | 21.3   | Carburetor .....   | 108 |
| 12.9  | Adjusting the basic position of the foot brake lever  .....     | 71 | 21.3.1 | All SX models .....  | 108 |
| 12.10 | Checking the rear brake fluid level .....  | 72 | 21.3.2 | Carburetor - basic setting for sandy surfaces (All SX models) .....  | 108 |
| 12.11 | Adding rear brake fluid  .....                                  | 73 | 21.3.3 | Carburetor tuning (All SX models) .....  | 109 |
| 12.12 | Checking the rear brake linings .....  | 73 | 21.3.4 | 250 XC US .....  | 110 |
| 12.13 | Changing the rear brake linings  .....                          | 74 | 21.3.5 | Carburetor tuning (250 XC US) .....  | 110 |
| 13    | WHEELS, TIRES .....  | 76 | 21.3.6 | 300 XC US .....  | 112 |
| 13.1  | Removing the front wheel  .....                                 | 76 | 21.3.7 | Carburetor tuning (300 XC US)  .....                    | 112 |
| 13.2  | Installing the front wheel  .....                               | 76 | 21.4   | Capacities .....   | 113 |
| 13.3  | Removing the rear wheel  .....                                  | 77 | 21.4.1 | Gear oil .....   | 113 |
| 13.4  | Installing the rear wheel  .....                                | 78 | 21.4.2 | Coolant .....  | 113 |
| 13.5  | Checking the tire condition .....  | 79 | 21.4.3 | Fuel .....   | 113 |
| 13.6  | Checking the tire air pressure .....   | 79 | 21.5   | Chassis .....  | 113 |
| 13.7  | Checking spoke tension .....   | 79 | 21.6   | Electrical system .....  | 114 |
| 14    | ELECTRICAL SYSTEM .....  | 81 | 21.7   | Tires .....  | 114 |
| 14.1  | Removing the battery  (All XC models) .....                     | 81 | 21.8   | Fork .....   | 114 |
| 14.2  | Installing the battery  (All XC models) .....                   | 81 | 21.8.1 | 250 SX EU .....  | 114 |
| 14.3  | Recharging the battery  (All XC models) .....                   | 82 | 21.8.2 | 250 SX US .....  | 114 |
| 14.4  | Changing the main fuse (All XC models) .....   | 83 | 21.8.3 | All XC models .....  | 115 |
| 15    | COOLING SYSTEM .....   | 84 | 21.9   | Shock absorber .....   | 115 |
| 15.1  | Cooling system .....   | 84 | 21.9.1 | 250 SX EU .....  | 115 |
| 15.2  | Checking the antifreeze and coolant level .....  | 84 | 21.9.2 | 250 SX US .....  | 116 |
| 15.3  | Checking the coolant level .....   | 85 | 21.9.3 | All XC models .....  | 116 |
| 15.4  | Draining the coolant  .....                                     | 85 | 21.10  | Chassis tightening torques .....   | 117 |
| 15.5  | Refilling with coolant  .....                                   | 86 | 22     | SUBSTANCES .....   | 119 |
|       |  |    | 23     | AUXILIARY SUBSTANCES .....   | 121 |
|       |  |    | 24     | STANDARDS .....  | 123 |







# TABLE OF CONTENTS

|    |                            |     |
|----|----------------------------|-----|
| 25 | LIST OF ABBREVIATIONS..... | 124 |
|    | INDEX.....                 | 125 |

## 1.1 Symbols used

The meaning of specific symbols is described below.

---

|  |   |
|--|---|
|  | Indicates an expected reaction (e.g. of a work step or a function).   |
|  | Indicates an unexpected reaction (e.g. of a work step or a function).   |
|  | All work marked with this symbol requires specialist knowledge and technical understanding. In the interest of your own safety, have these jobs performed by an authorized KTM workshop. There, your motorcycle will be optimally cared for by specially trained experts using the specialist tools required. |
|  | Indicates a page reference (more information is provided on the specified page).  |
|  | Indicates information with more details or tips.  |
|  | Indicates the result of a testing step.   |

---

## 1.2 Formats used

The typographical formats used in this document are explained below.

---

|                                |   |
|--------------------------------|---|
| <b>Specific name</b>           | Identifies a proprietary name.  |
| <b>Name<sup>®</sup></b>        | Identifies a protected name.  |
| <b>Brand<sup>™</sup></b>       | Identifies a brand available on the open market.  |
| <b><u>Underlined terms</u></b> | Refer to technical details of the vehicle or indicate technical terms that are explained in the glossary. |

---

## 2.1 Use definition – intended use

### (All SX models)

This vehicle is designed and built to withstand the normal stresses and strains of competitive use. This vehicle complies with the currently valid regulations and categories of the top international motorsport organizations.



#### Info

Only operate this vehicle in closed-off areas remote from public road traffic.

### (All XC models)

This vehicle is designed and built to withstand the normal stresses and strains of competitive use. This vehicle complies with the currently valid regulations and categories of the top international motorsport organizations.



#### Info

This vehicle is designed for use in offroad endurance competition, and not primarily for use in motocross. Only operate this vehicle in closed-off areas remote from public road traffic.

## 2.2 Misuse

The vehicle must only be used as intended.

Dangers can arise for people, property and the environment through use not as intended.

Any use of the vehicle beyond the intended and defined use constitutes misuse.

Misuse also includes the use of operating and auxiliary fluids which do not meet the required specification for the respective use.

## 2.3 Safety advice

A number of safety instructions need to be followed to operate the vehicle safely. Therefore, read this manual carefully. The safety instructions are highlighted in the text and are referred to at the relevant passages.



#### Info

The vehicle has various information and warning labels at prominent locations. Do not remove information/warning labels. If they are missing, you or others may not recognize dangers and may therefore be injured.

## 2.4 Degrees of risk and symbols



#### Danger

Indicates a danger that will immediately and invariably lead to fatal or serious permanent injury if the appropriate measures are not taken.



#### Warning

Indicates a danger that is likely to lead to fatal or serious injury if the appropriate measures are not taken.



#### Caution

Indicates a danger that may lead to minor injuries if the appropriate measures are not taken.

#### Note

Indicates a danger that will lead to considerable machine and material damage if the appropriate measures are not taken.



#### Warning

Indicates a danger that will lead to environmental damage if the appropriate measures are not taken.

## 2.5 Tampering warning

Tampering with the noise control system is prohibited. Federal law prohibits the following acts or the causing thereof:

- 1 The removal or rendering inoperative by any person other than for purposes of maintenance, repair, or replacement, of any device or element of design incorporated into any new vehicle for the purpose of noise control prior to its sale or delivery to the ultimate purchaser or while it is in use, or
- 2 the use of the vehicle after such device or element of design has been removed or rendered inoperative by any person.

Among those acts presumed to constitute tampering are the acts listed below:



- 1 Removal or puncturing of the main silencer, baffles, header pipes or any other components which conduct exhaust gases.
- 2 Removal or puncturing of parts of the intake system.
- 3 Lack of proper maintenance.
- 4 Replacing moving part of the vehicle, or parts of the exhaust or intake system, with parts other than those specified by the manufacturer.

### 2.6 Safe operation



#### **Danger**

**Danger of accidents** A rider who is not fit to ride poses a danger to him or herself and others.

- Do not operate the vehicle if you are not fit to ride due to alcohol, drugs or medication.
- Do not operate the vehicle if you are physically or mentally impaired.



#### **Danger**

**Danger of poisoning** Exhaust gases are toxic and inhaling them may result in unconsciousness and death.

- Always make sure there is sufficient ventilation when running the engine.
- Use an effective exhaust extraction system when starting or running the engine in an enclosed space.



#### **Warning**

**Danger of burns** Some vehicle components become very hot when the vehicle is operated.

- Do not touch any parts such as the exhaust system, radiator, engine, shock absorber, or brake system before the vehicle parts have cooled down.
- Let the vehicle parts cool down before you perform any work on the vehicle.

Only operate the vehicle when it is in perfect technical condition, in accordance with its intended use, and in a safe and environmentally compatible manner.

The vehicle should only be used by trained persons.

Have malfunctions that impair safety promptly eliminated by an authorized KTM workshop.

Adhere to the information and warning labels on the vehicle.

### 2.7 Protective clothing



#### **Warning**

**Risk of injury** Missing or poor protective clothing presents an increased safety risk.

- Wear appropriate protective clothing such as helmet, boots, gloves as well as trousers and a jacket with protectors on all rides.
- Always wear protective clothing that is in good condition and meets the legal regulations.

In the interest of your own safety, KTM recommends that you only operate the vehicle while wearing protective clothing.

### 2.8 Work rules

Special tools are necessary for certain tasks. The tools are not contained in the vehicle but can be ordered under the number in parentheses. E.g.: bearing puller (15112017000)

During assembly, non-reusable parts (e.g. self-locking screws and nuts, seals and seal rings, O-rings, pins, lock washers) must be replaced by new parts.

In some instances, a thread locker (e.g. **Loctite**®) is required. The manufacturer instructions for use must be followed.

After disassembly, clean the parts that are to be reused and check them for damage and wear. Change damaged or worn parts.

After you complete the repair or service work, check the operating safety of the vehicle.

### 2.9 Environment

If you use your motorcycle responsibly, you can ensure that problems and conflicts do not occur. To protect the future of the motorcycle sport, make sure that you use your motorcycle legally, display environmental consciousness, and respect the rights of others. When disposing of used oil, other operating and auxiliary fluids, and used components, comply with the laws and regulations of the respective country.

Because motorcycles are not subject to the EU regulations governing the disposal of used vehicles, there are no legal regulations that pertain to the disposal of an end-of-life motorcycle. Your authorized KTM dealer will be glad to advise you.

### 2.10 Owner's Manual

It is important that you read this Owner's Manual carefully and completely before making your first trip. The Owner's Manual contains useful information and many tips on how to operate, handle, and maintain your motorcycle. Only then will you find out how to customize the vehicle ideally for your own use and how you can protect yourself from injury.

Keep the Owner's Manual in an accessible place to enable you to refer to it as needed.

If you would like to know more about the vehicle or have questions on the material you read, please contact an authorized KTM dealer. The Owner's Manual is an important component of the vehicle and must be handed over to the new owner if the vehicle is sold.

## 3.1 Manufacturer and implied warranty

The work specified in the service schedule may only be performed in an authorized KTM workshop and must be recorded in both the Service & Warranty Booklet and in **KTM Dealer.net**, otherwise any warranty coverage will become void. Damage or secondary damage caused by tampering with and/or conversions on the vehicle are not covered by the warranty.

Additional information on the manufacturer or implied warranty and the procedures involved can be found in the Service & Warranty Booklet.

## 3.2 Operating and auxiliary substances



### Warning

**Environmental hazard** Improper handling of fuel is a danger to the environment.

- Do not allow fuel to enter the groundwater, the soil, or the sewage system.

Use operating and auxiliary substances (such as fuel and lubricants) as specified in the Owner's Manual.

## 3.3 Spare parts, accessories

For your own safety, only use spare parts and accessory products that are approved and/or recommended by KTM and have them installed by an authorized KTM workshop. KTM accepts no liability for other products and any resulting damage or loss. Certain spare parts and accessory products are specified in parentheses in the descriptions. Your authorized KTM dealer will be glad to advise you.

The current **KTM PowerParts** for your vehicle can be found on the KTM website.

International KTM Website: <http://www.ktm.com>

## 3.4 Service

A prerequisite for perfect operation and prevention of premature wear is that the service, care, and tuning work on the engine and chassis is properly carried out as described in the Owner's Manual. Incorrect adjustment and tuning of the engine and chassis can lead to damage and breakage of components.

Use of the vehicle under difficult conditions, such as on sand or on wet and muddy surfaces, can lead to considerably more rapid wear of components such as the drive train, brake system, or suspension components. For this reason, it may be necessary to inspect or replace parts before the next scheduled service.

It is imperative that you adhere to the stipulated run-in times and service intervals. If you observe these exactly, you will ensure a much longer service life for your motorcycle.

## 3.5 Figures

The figures contained in the manual may depict special equipment.

In the interest of clarity, some components may be shown disassembled or may not be shown at all. It is not always necessary to disassemble the component to perform the activity in question. Please follow the instructions in the text.

## 3.6 Customer service

Your authorized KTM dealer will be happy to answer any questions you may have on your vehicle and KTM.

A list of authorized KTM dealers can be found on the KTM website.

International KTM Website: <http://www.ktm.com>

## 4.1 View of vehicle, front left (example)



A00031-10

- |   |                            |
|---|----------------------------|
| 1 | Hand brake lever (📖 p. 13) |
| 2 | Kill switch (📖 p. 13)      |
| 3 | Clutch lever (📖 p. 13)     |
| 4 | Air filter box cover       |
| 5 | Plug-in stand              |
| 6 | Shift lever (📖 p. 16)      |
| 7 | Choke (📖 p. 16)            |
| 8 | Fuel tap                   |

## 4.2 View of vehicle, rear right (example)

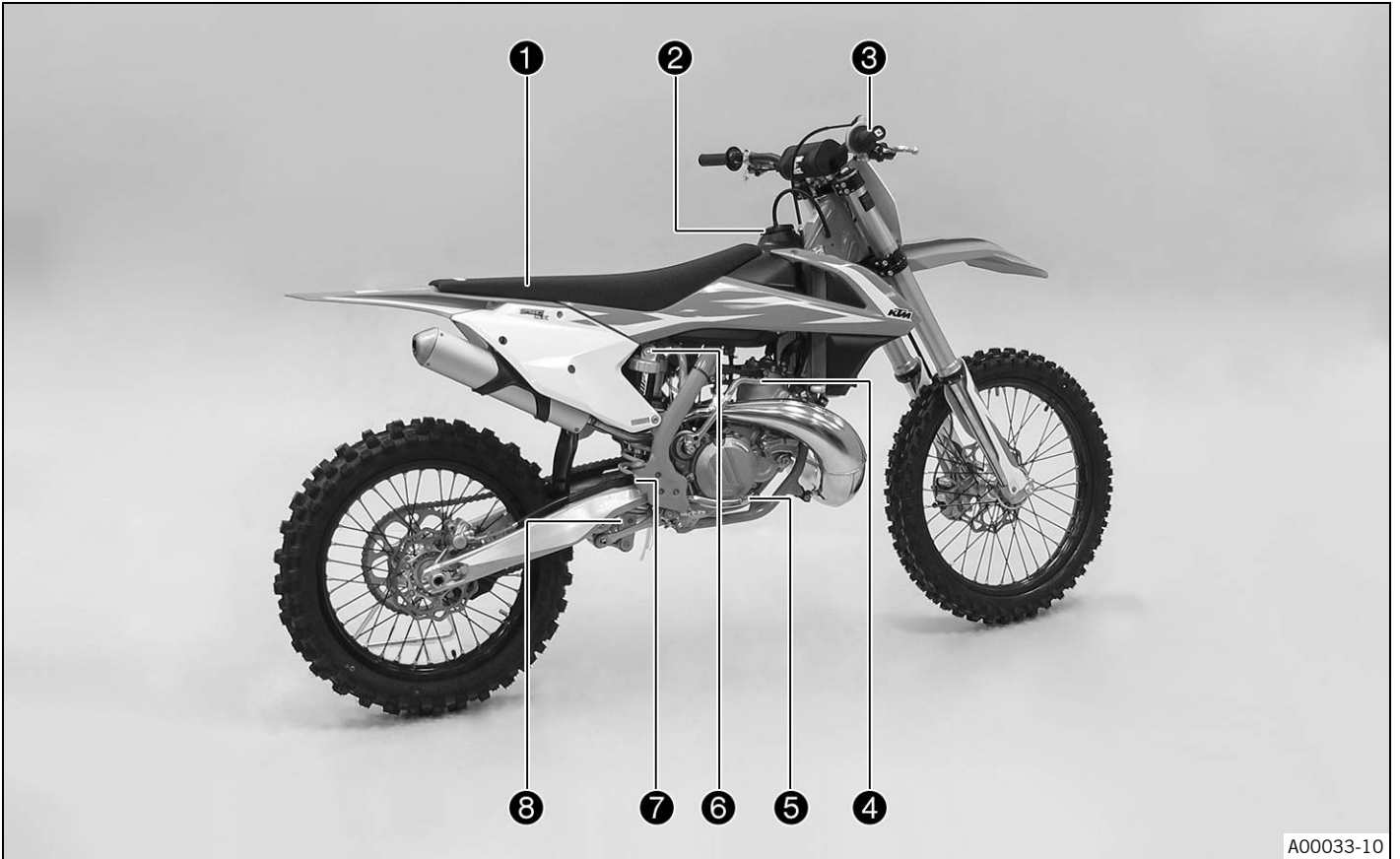

A00033-10

- |   |                                       |
|---|---------------------------------------|
| 1 | Seat                                  |
| 2 | Filler cap                            |
| 3 | Throttle grip (📖 p. 13)               |
| 4 | Kick starter (📖 p. 17)                |
| 5 | Foot brake lever (📖 p. 17)            |
| 6 | Shock absorber compression adjustment |
| 7 | Level viewer for brake fluid, rear    |
| 8 | Shock absorber rebound adjustment     |

## 5.1 Chassis number

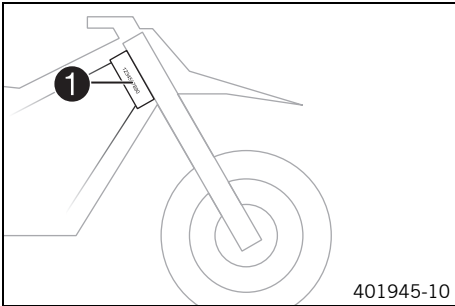

The chassis number ① is stamped on the right side of the steering head.

## 5.2 Type label

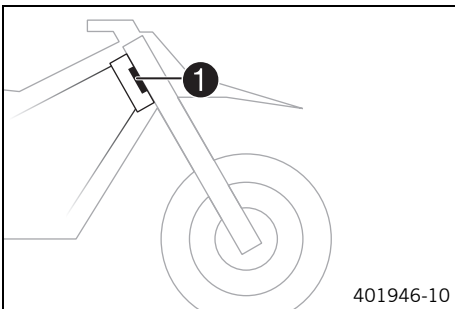

The type label ① is fixed to the front of the steering head.

## 5.3 Engine number

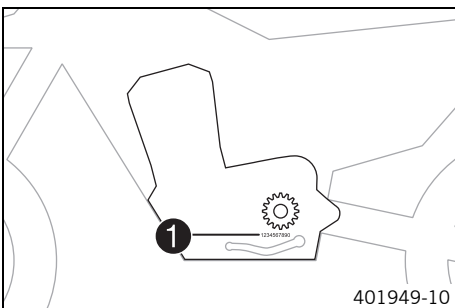

The engine number ① is stamped on the left side of the engine under the engine sprocket.

## 5.4 Fork part number

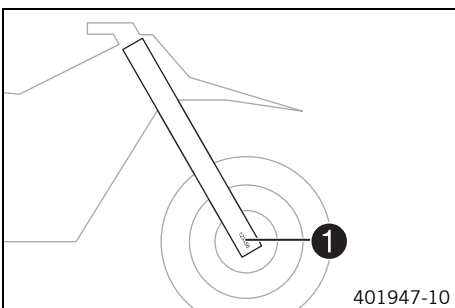

The fork part number ① is stamped on the inside of the axle clamp.

## 5.5 Shock absorber article number

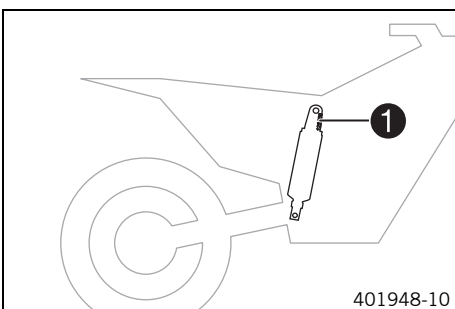

Shock absorber article number ① is stamped on the top of the shock absorber above the adjusting ring towards the engine side.

## 6.1 Clutch lever

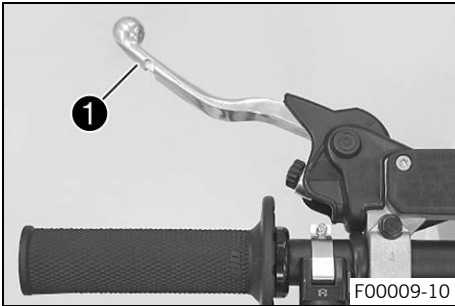

Clutch lever ❶ is fitted on the handlebar on the left.  
The clutch is activated hydraulically and adjusts itself automatically.

## 6.2 Hand brake lever

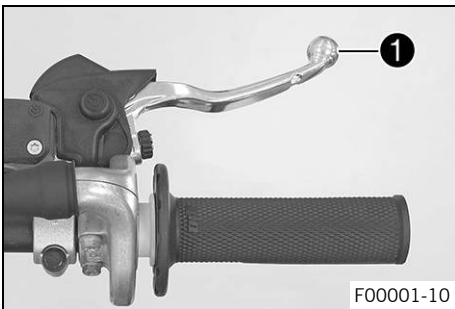

Hand brake lever ❶ is fitted on the right side of the handlebar.  
The front brake is engaged using the hand brake lever.

## 6.3 Throttle grip

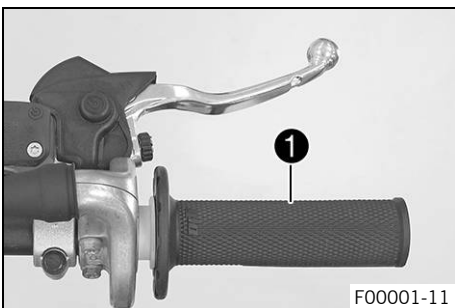

Throttle grip ❶ is fitted on the right side of the handlebar.

## 6.4 Kill switch

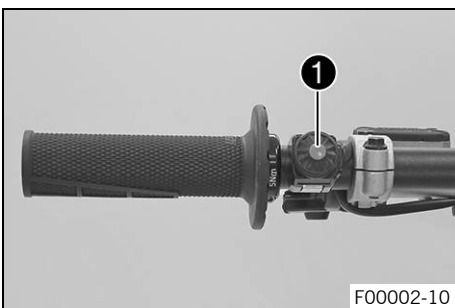

The kill switch ❶ is fitted on the left side of the handlebar.

### Possible states

- Kill switch ☒ in basic position – In this position, the ignition circuit is closed, and the engine can be started.
- Kill switch ☒ pressed – In this position, the ignition circuit is interrupted, a running engine stops, and a non-running engine will not start.

## 6.5 Electric starter button (All XC models)

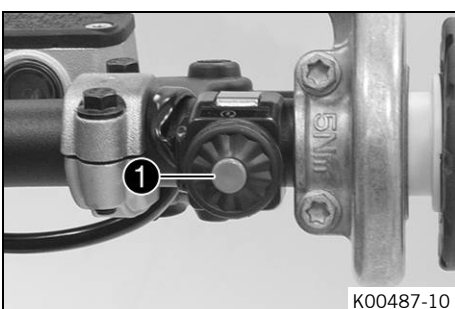

The electric starter button ❶ is fitted on the right side of the handlebar.

### Possible states

- Electric starter button ☒ in basic position
- Electric starter button ☒ pressed – In this position, the electric starter is actuated.

## 6.6 Opening the filler cap



### Danger

**Fire hazard** Fuel is highly flammable.

The fuel in the fuel tank expands when warm and can escape if overfilled.

- Do not refuel the vehicle in the vicinity of open flames or lit cigarettes.
- Switch off the engine for refueling.
- Make sure that no fuel is spilled; particularly not on hot parts of the vehicle.
- If any fuel is spilled, wipe it off immediately.
- Observe the specifications for refueling.



### Warning

**Danger of poisoning** Fuel is poisonous and a health hazard.

- Avoid skin, eye and clothing contact with fuel.
- Immediately consult a doctor if you swallow fuel.
- Do not inhale fuel vapors.
- In case of skin contact, rinse the affected area with plenty of water.
- Rinse the eyes thoroughly with water, and consult a doctor in case of fuel contact with the eyes.
- Change your clothing in case of fuel spills on them.
- Keep fuels correctly in a suitable canister, and out of the reach of children.



### Warning

**Environmental hazard** Improper handling of fuel is a danger to the environment.

- Do not allow fuel to enter the groundwater, the soil, or the sewage system.

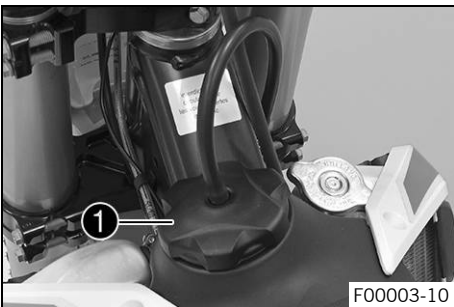

(All SX models)

- Turn filler cap ① counterclockwise and lift it off.



(All XC models)

- Press release button ①, turn the filler cap counterclockwise, and lift it off.

## 6.7 Closing the filler cap

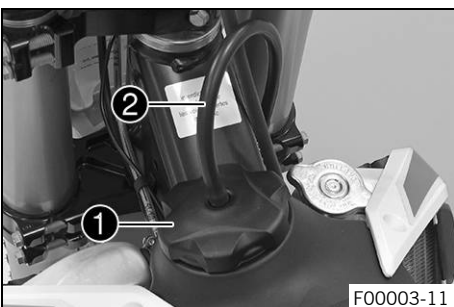

(All SX models)

- Mount filler cap ① and turn it clockwise until the fuel tank is tightly closed.



### Info

Run the fuel tank breather hose ② without kinks.



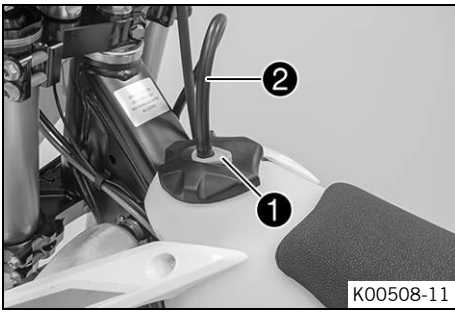

(All XC models)

- Mount filler cap **1** and turn it clockwise until the release button engages.

**i** Info

Run the fuel tank breather hose **2** without kinks.

## 6.8 Fuel tap (All SX models)

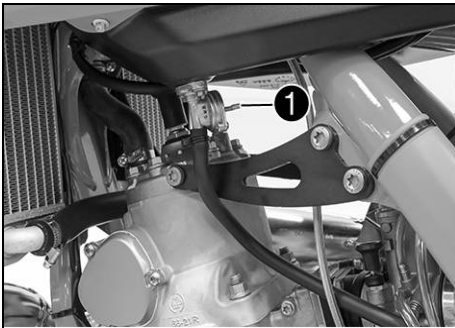

Fuel tap **1** is on the left of the fuel tank.

Open or close the supply of fuel to the carburetor using tap handle **1** on the fuel tap.

**Possible states**

- Fuel supply closed **OFF** – Fuel cannot flow from the fuel tank to the carburetor.
- Fuel supply open **ON** – Fuel can flow from the fuel tank to the carburetor. The fuel tank empties completely.

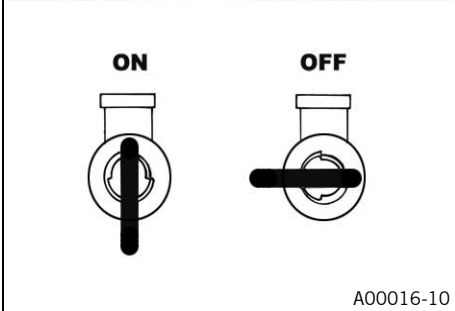

A00016-10

## 6.9 Fuel tap (All XC models)

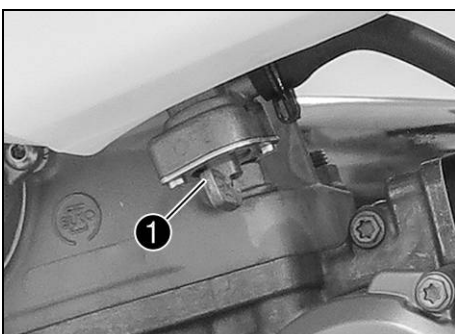

Fuel tap **1** is on the left of the fuel tank.

Open or close the supply of fuel to the carburetor using tap handle **1** on the fuel tap.

**Possible states**

- Fuel supply closed **OFF** – Fuel cannot flow from the fuel tank to the carburetor.
- Fuel supply open **ON** – Fuel can flow from the fuel tank to the carburetor. The fuel tank empties down to the reserve level.
- Fuel reserve supply open **RES** – Fuel can flow from the fuel tank to the carburetor. The fuel tank empties completely.

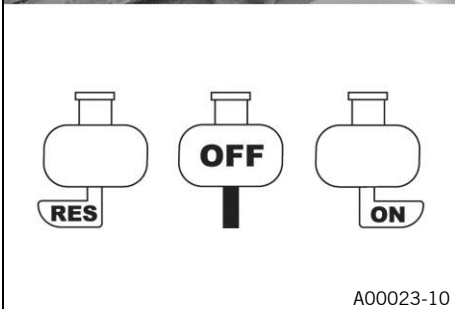

A00023-10

## 6.10 Choke

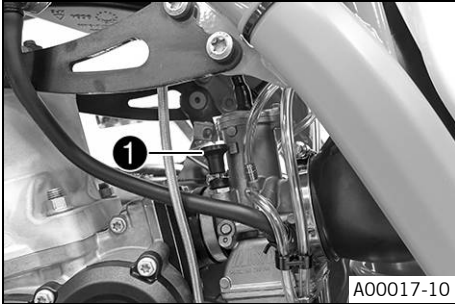

**(All SX models)**

Choke **1** is fitted on the left side of the carburetor.

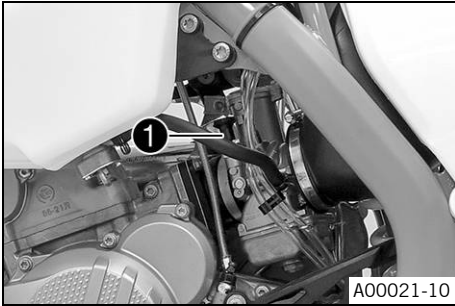

**(All XC models)**

Choke **1** is fitted on the left side of the carburetor.

Activating the choke function frees a drill hole in the carburetor through which the engine can draw extra fuel. This results in a richer fuel-air mixture, which is needed for a cold start.



**Info**

If the engine is warm, the choke function must be deactivated.

**Possible states**

- Choke function activated – The choke lever is pulled out to the stop.
- Choke function deactivated – The choke lever is pushed in to the stop.

## 6.11 Shift lever

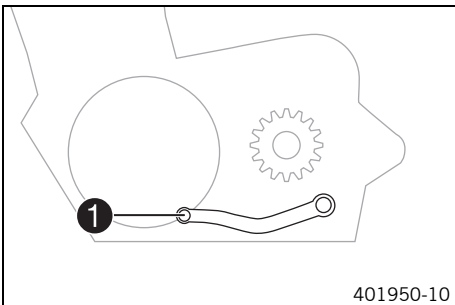

Shift lever **1** is mounted on the left of the engine.

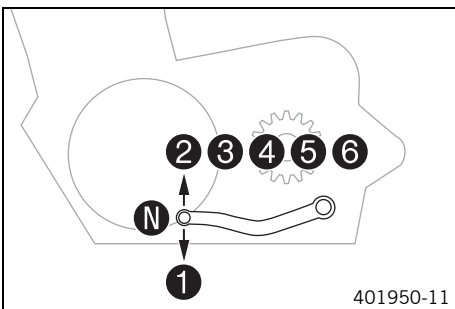

**(All XC models)**

The gear positions can be seen in the photograph.

The neutral or idle position is between the first and second gears.

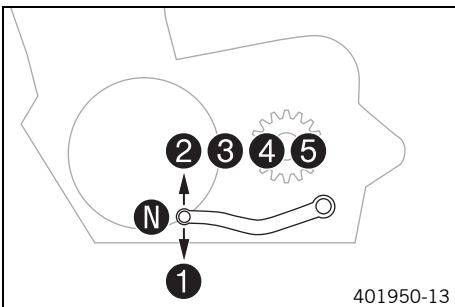

**(All SX models)**

The gear positions can be seen in the photograph.

The neutral or idle position is between the first and second gears.

## 6.12 Kick starter

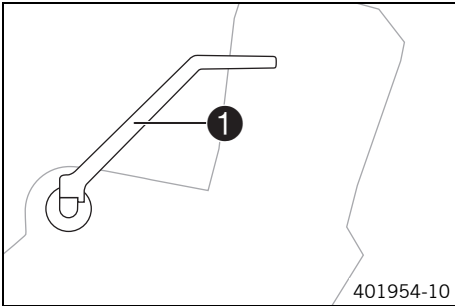

Kick starter **1** is fitted on the right side of the engine.  
The top part of the kick starter pivots.

**i** **Info**

Before riding, swing the top part of the kick starter inward toward the engine.

## 6.13 Foot brake lever

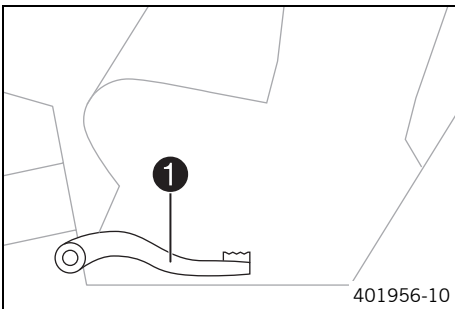

Foot brake lever **1** is located in front of the right footrest.  
The foot brake lever is used to activate the rear brake.

## 6.14 Plug-in stand (All SX models)

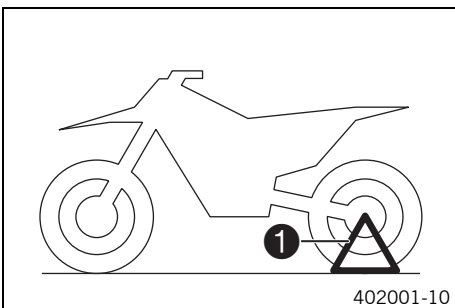

The holder for plug-in stand **1** is on the left side of the wheel spindle.  
The plug-in stand is used to park the motorcycle.

**i** **Info**

Remove the plug-in stand before riding.

## 6.15 Side stand (All XC models)

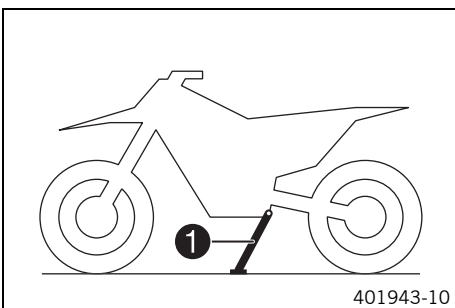

Side stand **1** is located on the left side of the vehicle.

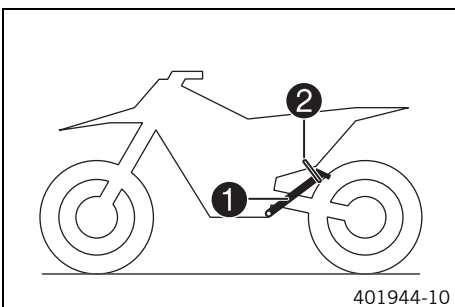

The side stand is used for parking the motorcycle.

**i** **Info**

When you are riding, side stand **1** must be folded up and secured with rubber band **2**.

## 6.16 Service hour counter

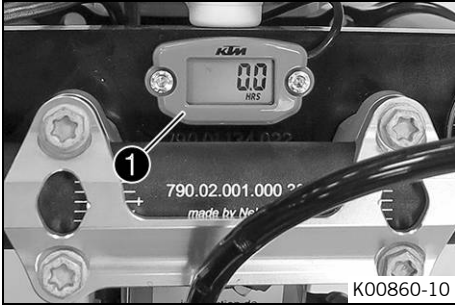

The service hour counter ① is fitted in front of the handlebar. It shows the total number of service hours of the engine. The service hour counter begins counting when the engine is started and stops when the engine is switched off.



### Info

It is not possible to delete or adjust anything on the service hour counter.

K00860-10

## 7.1 Advice on first use



### Danger

**Danger of accidents** A rider who is not fit to ride poses a danger to him or herself and others.

- Do not operate the vehicle if you are not fit to ride due to alcohol, drugs or medication.
- Do not operate the vehicle if you are physically or mentally impaired.



### Warning

**Risk of injury** Missing or poor protective clothing presents an increased safety risk.

- Wear appropriate protective clothing such as helmet, boots, gloves as well as trousers and a jacket with protectors on all rides.
- Always wear protective clothing that is in good condition and meets the legal regulations.



### Warning

**Danger of crashing** Different tire tread patterns on the front and rear wheel impair the handling characteristic.

Different tire tread patterns can make the vehicle significantly more difficult to control.

- Make sure that only tires with a similar tire tread pattern are fitted to the front and rear wheel.



### Warning

**Danger of accidents** An unadapted riding style impairs the handling characteristic.

- Adapt your riding speed to the road conditions and your riding ability.



### Warning

**Danger of accidents** The vehicle is not designed to carry passengers.

- Do not ride with a passenger.



### Warning

**Danger of accidents** The brake system fails in the event of overheating.

If the foot brake lever is not released, the brake linings drag continuously.

- Take your foot off the foot brake lever when you are not braking.



### Warning

**Danger of accidents** Total weight and axle loads influence the handling characteristic.

- Do not exceed the maximum permissible overall weight or the axle loads.



### Warning

**Risk of misappropriation** People who act without authorization endanger themselves and others.

- Do not leave the vehicle unattended if the engine is running.
- Protect the vehicle against access by unauthorized persons.



### Info

When using your motorcycle, remember that others may feel disturbed by excessive noise.

- Make sure that the pre-delivery inspection work has been carried out by an authorized KTM workshop.
  - ✓ You receive a delivery certificate and the Service and Warranty Booklet at vehicle handover.
- Before your first trip, read the entire Owner's Manual carefully.
- Get to know the controls.
- Adjust the basic position of clutch lever. (📖 p. 64)
- Adjust the basic position of the hand brake lever. (📖 p. 67)
- Adjust the basic position of the foot brake lever. 🦶 (📖 p. 71)
- Adjust the basic position of the shift lever. 🦶 (📖 p. 93)
- Get used to handling the motorcycle on a suitable surface before undertaking a more challenging trip.



### Info

Your motorcycle is not approved for use on public roads.

When off road, it is recommended that you are accompanied by another person on another vehicle so that you can help each other.

- Try also to ride as slowly as possible and in a standing position to get a better feeling for the motorcycle.
- Do not make any off-road trips that exceed your ability and experience.
- Hold the handlebar firmly with both hands and keep your feet on the footrests when riding.
- Do not take luggage along.
- Do not exceed the maximum permissible weight and the maximum permissible axle loads.

Guideline

|                                     |                  |
|-------------------------------------|------------------|
| Maximum permissible overall weight  | 335 kg (739 lb.) |
| Maximum permissible front axle load | 145 kg (320 lb.) |
| Maximum permissible rear axle load  | 190 kg (419 lb.) |

- Check the spoke tension. (📖 p. 79)



**Info**

The spoke tension must be checked after half an hour of operation.

- Run in the engine. (📖 p. 20)

## 7.2 Running in the engine

- During the running-in phase, do not exceed the specified engine performance.

Guideline

|                                    |         |
|------------------------------------|---------|
| Maximum engine performance         |         |
| During the first 3 operating hours | < 70 %  |
| During the first 5 operating hours | < 100 % |

- Avoid fully opening the throttle!

## 7.3 Preparing the vehicle for difficult riding conditions



**Info**

Use of the vehicle under difficult conditions, such as on sand or on wet and muddy surfaces, can lead to considerably more rapid wear of components such as the drive train, brake system, or suspension components. For this reason, it may be necessary to inspect or replace parts before the next scheduled service.

- Seal the air filter box. 🛠️ (📖 p. 55)
- Secure the air filter box cover. 🛠️ (📖 p. 55)
- Clean the air filter and air filter box. 🛠️ (📖 p. 54)



**Info**

Check the air filter approx. every 30 minutes.

- Check the electrical connector for humidity and corrosion and to ensure it is firmly seated.
  - » If humidity, corrosion, or damage is found:
    - Clean and dry the connector, or change it if necessary.

**Difficult riding conditions are:**

- Rides on dry sand. (📖 p. 21)
- Rides on wet sand. (📖 p. 22)
- Rides on wet and muddy surfaces. (📖 p. 23)
- Riding at high temperatures and low speeds. (📖 p. 23)
- Rides at low temperature or in snow. (📖 p. 24)

## 7.4 Preparing for rides on dry sand



- Check the radiator cap.

|                           |                  |
|---------------------------|------------------|
| Value on the radiator cap | 1.8 bar (26 psi) |
|---------------------------|------------------|

» If the indicated value does not correspond to the required value:



### Warning

**Danger of scalding** During motorcycle operation, the coolant gets very hot and is under pressure.

- Do not open the radiator, the radiator hoses or other cooling system components if the engine or the cooling system are at operating temperature.
- Allow the cooling system and the engine to cool down before you open the radiator, the radiator hoses or other components of the cooling system.
- In the event of scalding, rinse the area affected immediately with lukewarm water.

- Change the radiator cap.

- Fit a dust cover on the air filter.

|   |
|---|
| Dust cover for air filter (79006920000) |
|---|



### Info

See the **KTM PowerParts** fitting instructions.



- Fit a sand cover on the air filter.

|   |
|---|
| Sand cover for air filter (79006922000) |
|---|



### Info

See the **KTM PowerParts** fitting instructions.



- Adjust the carburetor jetting and setting.



### Info

Your authorized KTM workshop can recommend the right carburetor tuning.

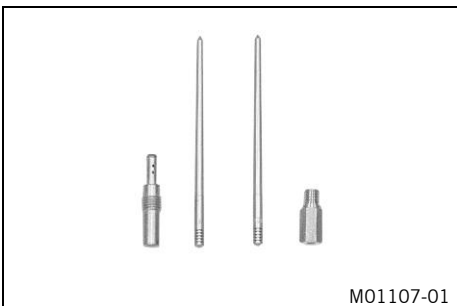

- Clean the chain.

|                          |
|--------------------------|
| Chain cleaner (📖 p. 121) |
|--------------------------|

- Fit the steel sprocket.



### Tip

Do not grease the chain.

- Clean the radiator fins.
- Straighten bent radiator fins carefully.



### Condition

Regular use in sand

- Change the piston every 10 operating hours.

## 7.5 Preparing for rides on wet sand

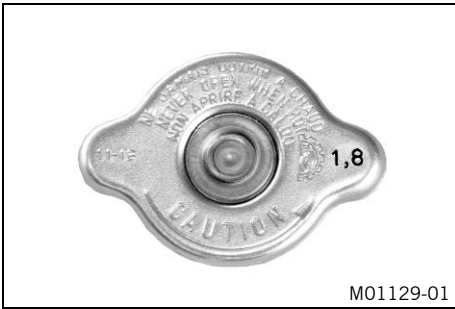

- Check the radiator cap.

|                           |                  |
|---------------------------|------------------|
| Value on the radiator cap | 1.8 bar (26 psi) |
|---------------------------|------------------|

- » If the indicated value does not correspond to the required value:



### Warning

**Danger of scalding** During motorcycle operation, the coolant gets very hot and is under pressure.

- Do not open the radiator, the radiator hoses or other cooling system components if the engine or the cooling system are at operating temperature.
- Allow the cooling system and the engine to cool down before you open the radiator, the radiator hoses or other components of the cooling system.
- In the event of scalding, rinse the area affected immediately with lukewarm water.

- Change the radiator cap.

- Fit a waterproofing device on the air filter.

|   |
|---|
| Waterproofing device for air filter (79006921000) |
|---|



### Info

See the **KTM PowerParts** fitting instructions.



- Adjust the carburetor jetting and setting.



### Info

Your authorized KTM workshop can recommend the right carburetor tuning.

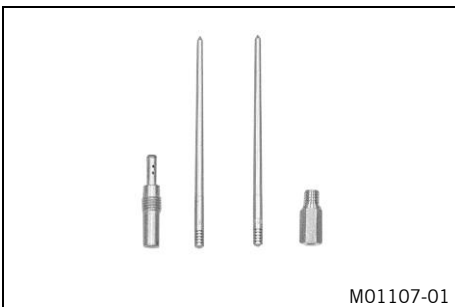

- Clean the chain.

|                          |
|--------------------------|
| Chain cleaner (📖 p. 121) |
|--------------------------|

- Fit the steel sprocket.



### Tip

Do not grease the chain.



- Clean the radiator fins.
- Straighten bent radiator fins carefully.

### Condition

Regular use in sand

- Change the piston every 10 operating hours.



## 7.6 Preparing for rides on wet and muddy surfaces



M01106-01

- Fit a waterproofing device on the air filter.

|   |
|---|
| Waterproofing device for air filter (79006921000) |
|---|



**Info**

See the **KTM PowerParts** fitting instructions.

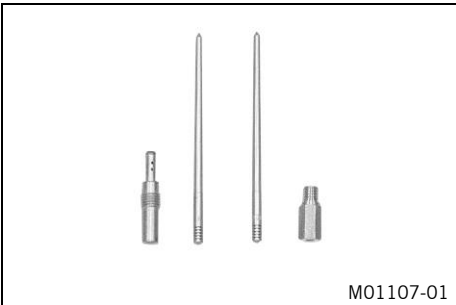

M01107-01

- Adjust the carburetor jetting and setting.



**Info**

Your authorized KTM workshop can recommend the right carburetor tuning.



600868-01

- Fit the steel sprocket.
- Clean the motorcycle. (📖 p. 99)
- Straighten bent radiator fins carefully.

## 7.7 Preparations for riding at high temperatures and low speeds



M01129-01

- Check the radiator cap.

|                           |                  |
|---------------------------|------------------|
| Value on the radiator cap | 1.8 bar (26 psi) |
|---------------------------|------------------|

» If the displayed value does not equal the setpoint value:



**Warning**

**Danger of scalding** During motorcycle operation, the coolant gets very hot and is under pressure.

- Do not open the radiator, the radiator hoses or other cooling system components if the engine or the cooling system are at operating temperature.
- Allow the cooling system and the engine to cool down before you open the radiator, the radiator hoses or other components of the cooling system.
- In the event of scalding, rinse the area affected immediately with lukewarm water.

- Change the radiator cap.

- Adjust the secondary ratio to the terrain.



**Info**

The engine oil heats up quickly when the clutch is operated frequently due to an excessively high secondary drive.



600868-01

- Clean the chain.

|                          |
|--------------------------|
| Chain cleaner (📖 p. 121) |
|--------------------------|

- Clean the radiator fins.

- Carefully align bent radiator fins.
- Check the coolant level. (📖 p. 85)

## 7.8 Preparing for rides at low temperature or in snow



- Fit a waterproofing device on the air filter.

Waterproofing device for air filter (79006921000)



### Info

See the **KTM PowerParts** fitting instructions.

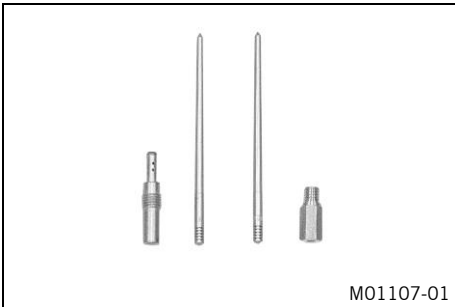

- Adjust the carburetor jetting and setting.



### Info

Your authorized KTM workshop can recommend the right carburetor tuning.

## 8.1 Checks and maintenance measures when preparing for use

**Info**

Before every trip, check the condition of the vehicle and ensure that it is safe to operate. The vehicle must be in perfect technical condition when it is being operated.

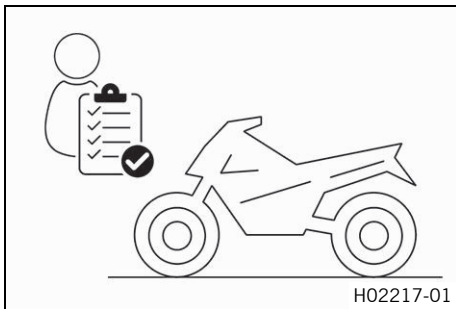

- Check the gear oil level. (📖 p. 97)
- Check the front brake fluid level. (📖 p. 68)
- Check the rear brake fluid level. (📖 p. 72)
- Check the front brake linings. (📖 p. 69)
- Check the rear brake linings. (📖 p. 73)
- Check that the brake system is functioning properly.
- Check the coolant level. (📖 p. 85)
- Check the chain for dirt. (📖 p. 59)
- Check the chain, rear sprocket, engine sprocket and chain guide. (📖 p. 61)
- Check the chain tension. (📖 p. 60)
- Check the tire condition. (📖 p. 79)
- Check the tire air pressure. (📖 p. 79)
- Check the spoke tension. (📖 p. 79)

**Info**

The spoke tension must be checked regularly as incorrect spoke tension will strongly impair riding safety.

- Clean the dust boots of the fork legs. (📖 p. 43)
- Bleed the fork legs. (📖 p. 43)
- Check the air filter.
- Check the settings of all controls and ensure that they can be operated smoothly.
- Check all screws, nuts, and hose clamps regularly for tightness.
- Check the fuel level.

## 8.2 Starting

**Danger**

**Danger of poisoning** Exhaust gases are toxic and inhaling them may result in unconsciousness and death.

- Always make sure there is sufficient ventilation when running the engine.
- Use an effective exhaust extraction system when starting or running the engine in an enclosed space.

**Note**

**Engine damage** High revving speed with a cold engine negatively impacts the lifespan of the engine.

- Always run the engine warm at a low speed.

**Info**

If the motorcycle is unwilling to start, the cause can be old fuel in the float chamber. The flammable elements of the fuel evaporate after a long time of standing.

If the float chamber is filled with fresh fuel, the engine starts immediately.

**The motorcycle has been out of use for more than 1 week**

- Empty the carburetor float chamber. 🛠️ (📖 p. 96)

**(All SX models)**

- Turn handle ❶ of the fuel tap to the **ON** position. (Figure A00016-10 📖 p. 15)
- ✓ Fuel can flow from the fuel tank to the carburetor.
- Remove the plug-in stand.
- Shift the transmission to idle.

**Condition**

The engine is cold

- Pull the choke lever out as far as possible.
- Press the kick starter robustly through its full range.

**i Info**  
Do not open the throttle.

**(All XC models)**

- Turn handle ① of the fuel tap to the **ON** position. (Figure A00023-10 p. 15)
- ✓ Fuel can flow from the fuel tank to the carburetor.
- Remove the motorcycle from the side stand.
- Shift the transmission to idle.

**Condition**

The engine is cold

- Pull the choke lever out as far as possible.
- Press the electric starter button or press the kick starter robustly through its full range.

**i Info**  
Do not open the throttle.

## 8.3 Starting off

**i Info**  
The plug-in stand must be removed before riding.  
While riding, the side stand must be folded up and secured with the rubber band.

- Pull the clutch lever, shift into first gear, release the clutch lever slowly and at the same time open the throttle gently.

## 8.4 Shifting, riding

**⚠ Warning**  
**Danger of accidents** If you change down at high engine speed, the rear wheel blocks and the engine races.

- Do not change into a low gear at high engine speed.

**i Info**  
If you hear unusual noises while riding, stop immediately, switch off the engine, and contact an authorized KTM workshop.  
First gear is used for starting off and for steep inclines.



- Shift into a higher gear when conditions allow (incline, road situation, etc.). To do so, release the throttle while simultaneously pulling the clutch lever, shift into the next gear, release the clutch lever and open the throttle.
- If the choke function has been activated, deactivate it after the engine has warmed up.
- After reaching maximum speed by fully opening the throttle grip, turn the throttle back so it is  $\frac{3}{4}$  open. This will barely reduce the speed but fuel consumption will be considerably lower.
- Always open the throttle only as much as the engine can handle – abrupt throttle opening increases fuel consumption.
- To shift down, apply the brakes and close the throttle at the same time.
- Pull the clutch lever and shift into a lower gear, release the clutch lever slowly, and either open the throttle or shift again.
- Switch off the engine if running at idle or stationary for a long time.

Guideline



|         |
|---------|
| ≥ 2 min |
|---------|

- Avoid frequent and longer slipping of the clutch. As a result the gear oil, engine and cooling system heat up.
- Ride at a low engine speed instead of at a high engine speed with a slipping clutch.

### 8.5 Applying the brakes

-  **Warning**  
**Danger of accidents** Excessively forceful application of the brakes blocks the wheels.
- Adjust application of the brakes to the respective riding situation and riding surface conditions.
-  **Warning**  
**Danger of accidents** A spongy pressure point on the front or rear brake reduces braking efficiency.
- Check the brake system and do not continue riding until the problem is eliminated. (Your authorized KTM workshop will be glad to help.)
-  **Warning**  
**Danger of accidents** Moisture and dirt impair the brake system.
- Brake carefully several times to dry out and remove dirt from the brake linings and the brake discs.
- 
- On sandy, wet, or slippery surfaces, use the rear brake mostly if possible.
  - Always finish braking before you go into a bend. Change down to a lower gear appropriate to your road speed.
  - Use the braking effect of the engine on long downhill stretches. Change down one or two gears, but do not over-rev the engine. You will have to apply the brakes far less frequently as a result and the brake system will not overheat.

### 8.6 Stopping, parking

-  **Warning**  
**Risk of misappropriation** People who act without authorization endanger themselves and others.
- Do not leave the vehicle unattended if the engine is running.
  - Protect the vehicle against access by unauthorized persons.
-  **Warning**  
**Danger of burns** Some vehicle components become very hot when the vehicle is operated.
- Do not touch any parts such as the exhaust system, radiator, engine, shock absorber, or brake system before the vehicle parts have cooled down.
  - Let the vehicle parts cool down before you perform any work on the vehicle.

#### Note

**Fire hazard** Hot vehicle components pose a fire hazard and explosion risk.

- Do not park the vehicle near to materials which are highly flammable or explosive.
- Allow the vehicle to cool down before covering it.

#### Note

**Material damage** The vehicle may be damaged by incorrect procedure when parking.

Significant damage may be caused if the vehicle rolls away or falls over.

The components for parking the vehicle are designed only for the weight of the vehicle.

- Park the vehicle on a firm and level surface.
- Ensure that nobody sits on the vehicle when the vehicle is parked on a stand.

- 
- Apply the brakes on the motorcycle.
  - Shift gear to neutral.
  - Press and hold the kill switch ☒ while the engine is idling until the engine stops.

#### (All SX models)

- Turn handle ① of the fuel tap to the **OFF** position. (Figure A00016-10  p. 15)
- Rest the vehicle on the plug-in stand.

#### (All XC models)

- Turn handle ① of the fuel tap to the **OFF** position. (Figure A00023-10  p. 15)
- Rest the vehicle on the side stand.

## 8.7 Transport

**Note**

**Danger of damage** The parked vehicle can roll away or fall over.

- Park the vehicle on a firm and level surface.

**Note**

**Fire hazard** Hot vehicle components pose a fire hazard and explosion risk.

- Do not park the vehicle near to materials which are highly flammable or explosive.
- Allow the vehicle to cool down before covering it.

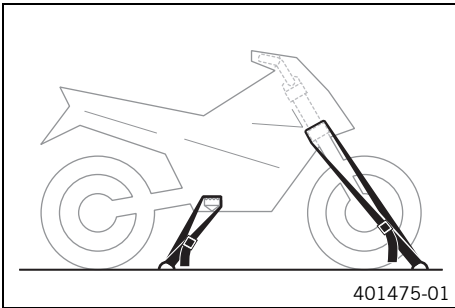

- Switch off the engine.
- Use tension belts or other suitable devices to secure the motorcycle against accidents or falling over.

## 8.8 Refueling



**Danger**

**Fire hazard** Fuel is highly flammable.

The fuel in the fuel tank expands when warm and can escape if overfilled.

- Do not refuel the vehicle in the vicinity of open flames or lit cigarettes.
- Switch off the engine for refueling.
- Make sure that no fuel is spilled; particularly not on hot parts of the vehicle.
- If any fuel is spilled, wipe it off immediately.
- Observe the specifications for refueling.



**Warning**

**Danger of poisoning** Fuel is poisonous and a health hazard.

- Avoid skin, eye and clothing contact with fuel.
- Immediately consult a doctor if you swallow fuel.
- Do not inhale fuel vapors.
- In case of skin contact, rinse the affected area with plenty of water.
- Rinse the eyes thoroughly with water, and consult a doctor in case of fuel contact with the eyes.
- Change your clothing in case of fuel spills on them.



**Warning**

**Environmental hazard** Improper handling of fuel is a danger to the environment.

- Do not allow fuel to enter the groundwater, the soil, or the sewage system.

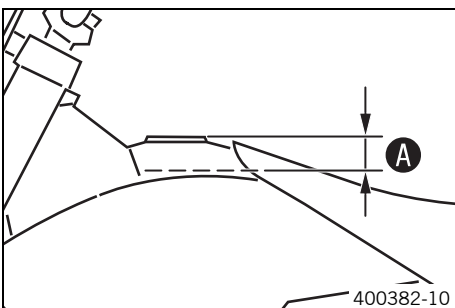

- Switch off the engine.
- Open the filler cap. (📖 p. 14)
- Fill the fuel tank with fuel up to measurement **A**.

Guideline

|   |                   |   |
|---|-------------------|---|
| Measurement of <b>A</b>                           | 35 mm (1.38 in)   |   |
| Total fuel tank capacity, approx. (All SX models) | 7 l (1.8 US gal)  | Super unleaded (95 octane) mixed with 2-stroke engine oil (1:60) (📖 p. 120) |
| Total fuel tank capacity, approx. (All XC models) | 10 l (2.6 US gal) | Super unleaded (95 octane) mixed with 2-stroke engine oil (1:60) (📖 p. 120) |

Engine oil, 2-stroke (📖 p. 119)

- Close the filler cap. (📖 p. 14)

## 9.1 Additional information

Any further work that results from the required work or from the recommended work must be ordered separately and can be invoiced separately.  
 Different service intervals may apply in your country, depending on the local operating conditions.

## 9.2 Required work

|   | after every race            |                          |                          |                              |
|---|-----------------------------|--------------------------|--------------------------|------------------------------|
|   | Every 40 operating hours    | Every 20 operating hours | Every 10 operating hours | Once after 5 operating hours |
|   | Once after 1 operating hour |                          |                          |                              |
| Check and charge the battery.  (All XC models)  |                             |                          | •                        | •                            |
| Change the gear oil.  (p. 97)   | ○                           |                          | •                        | •                            |
| Check the front brake linings. (p. 69)  |                             |                          | •                        | •                            |
| Check the rear brake linings. (p. 73)   |                             |                          | •                        | •                            |
| Check the brake discs. (p. 67)  |                             |                          | •                        | •                            |
| Check the brake lines for damage and leakage.   |                             |                          | •                        | •                            |
| Check the rear brake fluid level. (p. 72)   |                             |                          | •                        | •                            |
| Check the free travel of the foot brake lever. (p. 71)  |                             |                          | •                        | •                            |
| Check the frame.  (p. 63)   |                             |                          | •                        | •                            |
| Check the swingarm.  (p. 63)  |                             |                          | •                        | •                            |
| Check the swingarm bearing for backlash.  |                             |                          | •                        | •                            |
| Check the heim joint for play.  |                             |                          | •                        | •                            |
| Check the shock absorber linkage.   |                             |                          | •                        | •                            |
| Check the tire condition. (p. 79)   | ○                           |                          | •                        | •                            |
| Check the tire air pressure. (p. 79)  | ○                           |                          | •                        | •                            |
| Check the wheel bearing for play.   |                             |                          | •                        | •                            |
| Check the wheel hubs.   |                             |                          | •                        | •                            |
| Check the rim run-out.  | ○                           |                          | •                        | •                            |
| Check the spoke tension. (p. 79)  | ○                           |                          | •                        | •                            |
| Check the chain, rear sprocket, engine sprocket and chain guide. (p. 61)  |                             |                          | •                        | •                            |
| Check the chain tension. (p. 60)  | ○                           |                          | •                        | •                            |
| Grease all moving parts (e.g., hand lever, chain, ...) and check for smooth operation.                                |                             |                          | •                        | •                            |
| Check/correct the fluid level of the hydraulic clutch. (p. 65)  |                             |                          | •                        | •                            |
| Check the front brake fluid level. (p. 68)  |                             |                          | •                        | •                            |
| Check the free travel of the hand brake lever. (p. 67)  |                             |                          | •                        | •                            |
| Check the play of the steering head bearing. (p. 47)  | ○                           |                          | •                        | •                            |
| Change the spark plug and spark plug connector.   |                             |                          | •                        | •                            |
| Check all hoses (e.g. fuel, cooling, bleeder, drainage, etc.) and sleeves for cracking, leaks, and incorrect routing. | ○                           |                          | •                        | •                            |
| Check the antifreeze and coolant level. (p. 84)   | ○                           |                          | •                        | •                            |
| Check the cables for damage and for routing without kinks.  |                             |                          | •                        | •                            |
| Check that the throttle cables are undamaged, routed without sharp bends, and set correctly.                          | ○                           |                          | •                        | •                            |
| Clean the air filter and air filter box.  (p. 54)   |                             |                          | •                        | •                            |
| Change glass fiber yarn filling in the main silencer.  (p. 56)  |                             |                          | •                        | •                            |
| Service the fork.   |                             |                          | •                        | •                            |
| Service the shock absorber.   |                             |                          | •                        | •                            |
| Check the screws and nuts for tightness.  | ○                           |                          | •                        | •                            |
| Check idle.   | ○                           |                          | •                        | •                            |
| Final check: Check the vehicle for operating safety and take a test ride.   | ○                           | ○                        | •                        | •                            |
| Make the service entry in the <b>KTM Dealer.net</b> and in the Service and Warranty Booklet.                          | ○                           | ○                        | •                        | •                            |



- One-time interval
- Periodic interval

## 9.3 Recommended work

|  | Every 40 operating hours when used for motorsports       |                          |                          |          |
|--|--|--------------------------|--------------------------|----------|
|  |  |                          | Every 80 operating hours | Annually |
|  |  | Every 40 operating hours |                          |          |
|  | Once after 20 operating hours / Every 20 operating hours |                          |                          |          |
|  | Once after 10 operating hours / Every 10 operating hours |                          |                          |          |
| Change the front brake fluid. 🛠️   |  |                          |                          | ●        |
| Change the rear brake fluid. 🛠️  |  |                          |                          | ●        |
| Change the hydraulic clutch fluid. 🛠️ (📖 p. 65)  |  |                          |                          | ●        |
| Grease the steering head bearing. 🛠️ (📖 p. 48)   |  |                          |                          | ●        |
| Service the fork. 🛠️   | ○  |                          |                          |          |
| Service the shock absorber. 🛠️   |  | ○                        |                          |          |
| Check/set the carburetor components. 🛠️  |  |                          | ● ● ●                    |          |
| Check the electric starter drive. (All XC models) 🛠️   |  |                          | ● ●                      |          |
| Check the reed valve housing, reed valve, and intake flange. (All XC models) 🛠️  |  | ● ● ●                    |                          |          |
| Perform minor engine service. (Check the reed valve housing, reed valve, and intake flange. Check the clutch. Under difficult operating conditions: Change the piston and check the cylinder and Z dimension.) 🛠️ (All SX models)  | ● ● ● ●  |                          |                          |          |
| Perform the intermediate engine service. (Change the piston and check the cylinder and Z dimension. Check the exhaust control for functioning and smooth operation.) 🛠️ (All SX models)  |  | ● ● ●                    |                          |          |
| Perform major engine service including removing and installing the engine. (Change the connecting rod, conrod bearing, and crank pin. Check the transmission and shift mechanism. Change all engine bearings.) 🛠️ (All SX models)  |  |                          | ● ●                      |          |
| Perform minor engine service. (Check the exhaust control for functioning and smooth operation. Check the clutch.) 🛠️ (All XC models)   |  |                          | ● ●                      |          |
| Perform major engine service including removing and installing the engine. Change the piston and check the cylinder. Change the connecting rod, conrod bearing, and crank pin. Check the transmission and shift mechanism. Change all engine bearings.) 🛠️ (All XC models) |  |                          |                          | ● ●      |

- One-time interval
- Periodic interval

## 10.1 Checking the basic chassis setting with the rider's weight

**i Info** When adjusting the basic chassis setting, first adjust the shock absorber and then the fork.

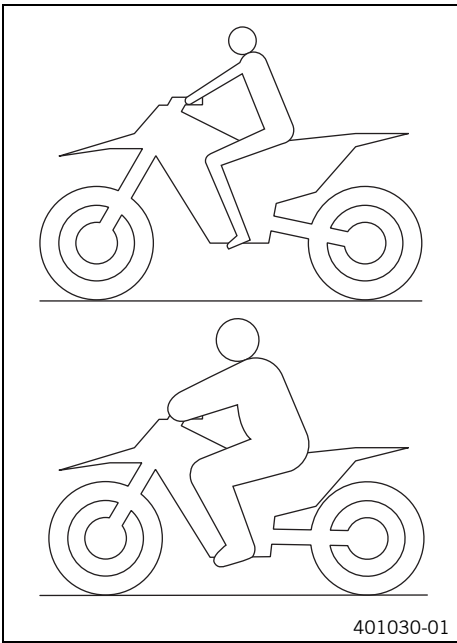

401030-01

- For optimal motorcycle riding characteristics and to avoid damage to forks, shock absorbers, swingarm and frame, the basic settings of the suspension components must match the rider's weight.
- As delivered, KTM offroad motorcycles are adjusted for an average rider's weight (with full protective clothing).

Guideline

|                       |                              |
|-----------------------|------------------------------|
| Standard rider weight | 75... 85 kg (165... 187 lb.) |
|-----------------------|------------------------------|

- If the rider's weight is above or below this range, the basic setting of the suspension components must be adjusted accordingly.
- Small weight differences can be compensated by adjusting the spring preload, but in the case of large weight differences, the springs must be replaced.

## 10.2 Air suspension AER 48



M01110-01

Air suspension **WP Performance Systems AER 48** is used in the fork. In this system, suspension is located in the left fork leg and damping in the right fork leg. As fork springs are no longer required, a significant weight advantage is achieved when compared to conventional forks. The response on slightly uneven surfaces is significantly improved. In normal driving mode, suspension is provided exclusively by an air cushion. A steel spring is located in the left fork leg as an end stop.

**i Info** If the fork is frequently overloaded, then the air pressure in the fork must be increased to avoid damage to the fork and frame.

The air pressure in the fork can be quickly adjusted for the rider's weight, surface conditions and the rider's preference using a fork pump. The fork does not have to be detached. The time consuming mounting of harder or softer fork springs is not required.

If the air chamber loses air due to a damaged seal, the fork will still not sag. In this case the air is retained in the fork. The suspension travel is maintained as far as possible. The damping becomes harder and the riding comfort reduces.

As with a conventional fork, the damping can be adjusted in rebound and compression stages.

The rebound adjuster is located at the lower end of the right fork leg.

The compression adjuster is located at the upper end of the right fork leg.

## 10.3 Compression damping of the shock absorber

The compression damping of the shock absorber is divided into two ranges: high-speed and low-speed.

High-speed and low-speed refer to the compression speed of the rear wheel suspension and not to the vehicle speed.

The high-speed setting, for example, has an effect on the landing after a jump: the rear wheel suspension compresses quickly.

The low-speed setting, for example, has an effect when riding over long ground swells: the rear wheel suspension compresses slowly.

These two ranges can be adjusted separately, although the transition between high-speed and low-speed is gradual. Thus, changes in the high-speed range affect the compression damping in the low-speed range and vice versa.

## 10.4 Adjusting the low-speed compression damping of the shock absorber

**Caution**  
**Risk of injury** Parts of the shock absorber will fly off if the shock absorber is disassembled incorrectly. The shock absorber is filled with highly compressed nitrogen.  
 – Please follow the description provided. (Your authorized KTM workshop will be glad to help.)

**Info**  
 The effect of the low-speed setting can be seen in slow to normal compression of the shock absorber.

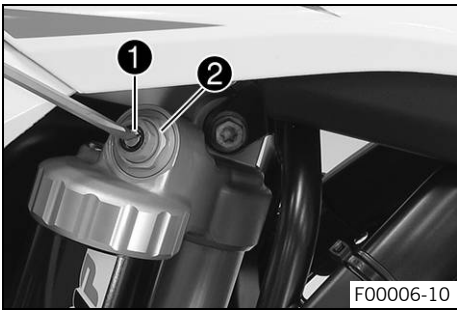

- Turn adjusting screw ① clockwise with a screwdriver up to the last perceptible click.

**Info**  
 Do not loosen fitting ②!

- Turn counterclockwise by the number of clicks corresponding to the shock absorber type.

Guideline

| Compression damping, low-speed (250 SX EU)     |           |
|--|-----------|
| Comfort  | 17 clicks |
| Standard                                       | 15 clicks |
| Sport  | 13 clicks |
| Compression damping, low-speed (250 SX US)     |           |
| Comfort  | 17 clicks |
| Standard                                       | 15 clicks |
| Sport  | 13 clicks |
| Compression damping, low-speed (All XC models) |           |
| Comfort  | 17 clicks |
| Standard                                       | 15 clicks |
| Sport  | 13 clicks |

**Info**  
 Turn clockwise to increase damping; turn counterclockwise to reduce damping.

## 10.5 Adjusting the high-speed compression damping of the shock absorber

**Caution**  
**Risk of injury** Parts of the shock absorber will fly off if the shock absorber is disassembled incorrectly. The shock absorber is filled with highly compressed nitrogen.  
 – Please follow the description provided. (Your authorized KTM workshop will be glad to help.)

**Info**  
 The effect of the high-speed setting can be seen in fast compression of the shock absorber.

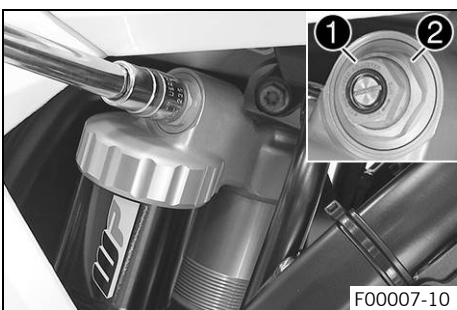

- Turn adjusting screw ① all the way clockwise with a socket wrench.

**Info**  
 Do not loosen fitting ②!

- Turn counterclockwise by the number of turns corresponding to the shock absorber type.

Guideline

|   |           |
|---|-----------|
| Compression damping, high-speed (250 SX EU)     |           |
| Comfort   | 2 turns   |
| Standard  | 1.5 turns |
| Sport   | 1 turn    |
| Compression damping, high-speed (250 SX US)     |           |
| Comfort   | 2.5 turns |
| Standard  | 2 turns   |
| Sport   | 1.5 turns |
| Compression damping, high-speed (All XC models) |           |
| Comfort   | 2.5 turns |
| Standard  | 2 turns   |
| Sport   | 1.5 turns |

**i Info**  
Turn clockwise to increase damping; turn counterclockwise to reduce damping.

## 10.6 Adjusting the rebound damping of the shock absorber



**Caution**

**Risk of injury** Parts of the shock absorber will fly off if the shock absorber is disassembled incorrectly. The shock absorber is filled with highly compressed nitrogen.

- Please follow the description provided. (Your authorized KTM workshop will be glad to help.)

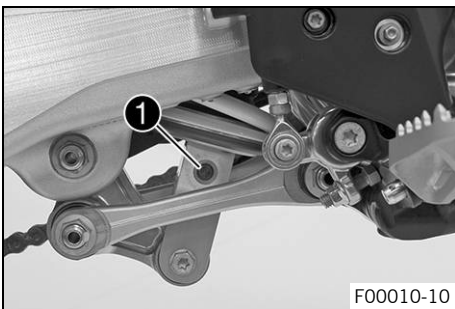

- Turn adjusting screw **1** clockwise up to the last perceptible click.
- Turn counterclockwise by the number of clicks corresponding to the shock absorber type.

Guideline

|                                 |           |
|---------------------------------|-----------|
| Rebound damping (250 SX EU)     |           |
| Comfort                         | 17 clicks |
| Standard                        | 15 clicks |
| Sport                           | 13 clicks |
| Rebound damping (250 SX US)     |           |
| Comfort                         | 17 clicks |
| Standard                        | 15 clicks |
| Sport                           | 13 clicks |
| Rebound damping (All XC models) |           |
| Comfort                         | 17 clicks |
| Standard                        | 15 clicks |
| Sport                           | 13 clicks |

**i Info**  
Turn clockwise to increase damping; turn counterclockwise to reduce damping.

## 10.7 Measuring the rear wheel dimension unloaded

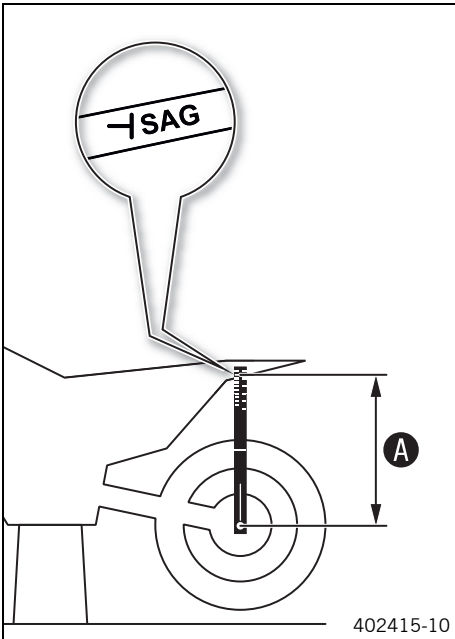

### Preparatory work

- Raise the motorcycle with a lift stand. (📖 p. 42)

### Main work

- Position the sag gauge in the rear axle and measure the distance to marking **SAG** on the rear fender.

|                         |
|-------------------------|
| Sag gauge (00029090000) |
|-------------------------|

|                                 |
|---------------------------------|
| Pin for sag gauge (00029990010) |
|---------------------------------|

- Note down the value as dimension **A**.

### Finishing work

- Remove the motorcycle from the lift stand. (📖 p. 42)

## 10.8 Checking the static sag of the shock absorber

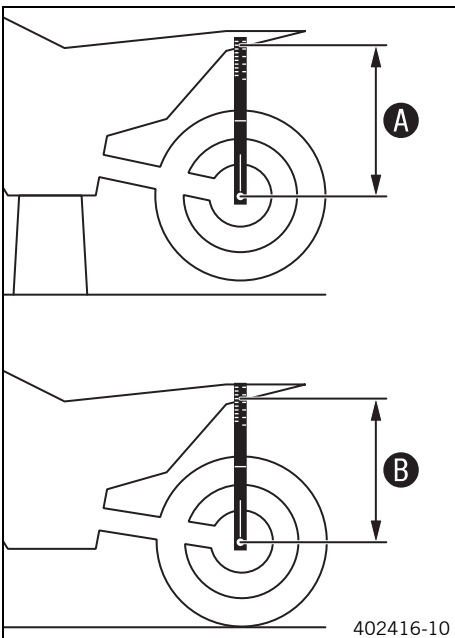

- Measure dimension **A** of rear wheel unloaded. (📖 p. 35)
- Hold the motorcycle upright with the aid of an assistant.
- Again measure the distance between the rear axle and marking **SAG** on the rear fender using the sag gauge.
- Note down the value as dimension **B**.

### **i** Info

The static sag is the difference between measurements **A** and **B**.

- Check the static sag.

|                        |                 |
|------------------------|-----------------|
| Static sag (250 SX EU) | 35 mm (1.38 in) |
|------------------------|-----------------|

|                        |                 |
|------------------------|-----------------|
| Static sag (250 SX US) | 35 mm (1.38 in) |
|------------------------|-----------------|

|                            |                 |
|----------------------------|-----------------|
| Static sag (All XC models) | 35 mm (1.38 in) |
|----------------------------|-----------------|

- » If the static sag is less or more than the specified value:
  - Adjust the spring pretension of the shock absorber. 🛠️ (📖 p. 36)

## 10.9 Checking the riding sag of the shock absorber

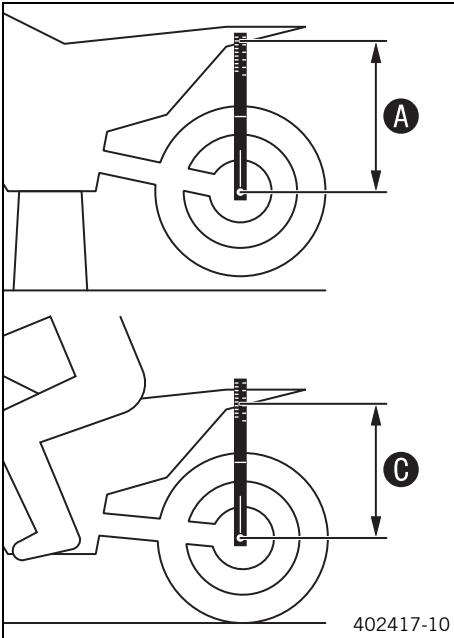

- Measure dimension **A** of rear wheel unloaded. (📖 p. 35)
- With another person holding the motorcycle, the rider, wearing full protective clothing, sits on the seat in a normal sitting position (feet on footrests) and bounces up and down a few times.
  - ✓ The rear wheel suspension levels out.
- Another person again measures the distance between the rear axle and marking **SAG** on the rear fender using the sag gauge.
- Note down the value as dimension **C**.

**i Info**

The riding sag is the difference between measurements **A** and **C**.

- Check the riding sag.

Guideline

|                            |                  |
|----------------------------|------------------|
| Riding sag (250 SX EU)     | 105 mm (4.13 in) |
| Riding sag (250 SX US)     | 105 mm (4.13 in) |
| Riding sag (All XC models) | 105 mm (4.13 in) |

- » If the riding sag differs from the specified measurement:
  - Adjust the riding sag. 🛠️ (📖 p. 37)

## 10.10 Adjusting the spring pretension of the shock absorber 🛠️

**⚠ Caution**

**Risk of injury** Parts of the shock absorber will fly off if the shock absorber is disassembled incorrectly. The shock absorber is filled with highly compressed nitrogen.

- Please follow the description provided. (Your authorized KTM workshop will be glad to help.)

**i Info**

Before changing the spring pretension, make a note of the present setting, e.g., by measuring the length of the spring.

**Preparatory work**

- Raise the motorcycle with a lift stand. (📖 p. 42)
- Remove the shock absorber. 🛠️ (📖 p. 50)
- After removing the shock absorber, clean it thoroughly.

**Main work**

- Loosen screw **1**.
- Turn adjusting ring **2** until the spring is no longer under tension.

Hook wrench (90129051000)

- Measure the overall spring length while the spring is not under tension.
- Tighten the spring by turning adjusting ring **2** to measurement **A**.

Guideline

|                                |                |
|--------------------------------|----------------|
| Spring preload (250 SX EU)     | 6 mm (0.24 in) |
| Spring preload (250 SX US)     | 5 mm (0.2 in)  |
| Spring preload (All XC models) | 8 mm (0.31 in) |

**i Info**

Depending on the static sag and/or the riding sag, it may be necessary to increase or decrease the spring pretension.

- Tighten screw **1**.

Guideline

|                                      |    |                   |
|--------------------------------------|----|-------------------|
| Screw, shock absorber adjusting ring | M5 | 5 Nm (3.7 lbf ft) |
|--------------------------------------|----|-------------------|

**Finishing work**

- Install the shock absorber. 🛠️ (📖 p. 51)

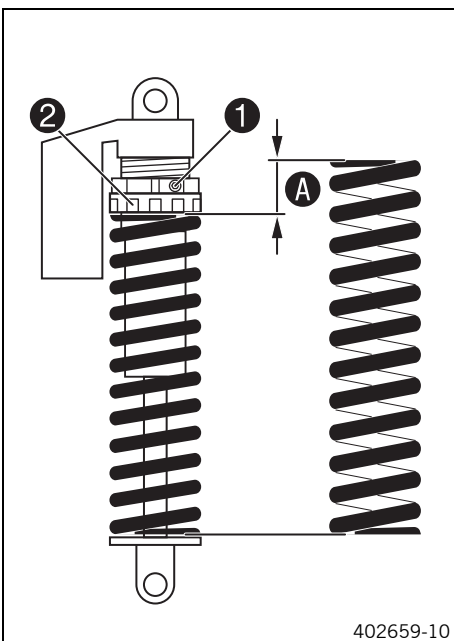

- Remove the motorcycle from the lift stand. (📖 p. 42)

## 10.11 Adjusting the riding sag 🛠️

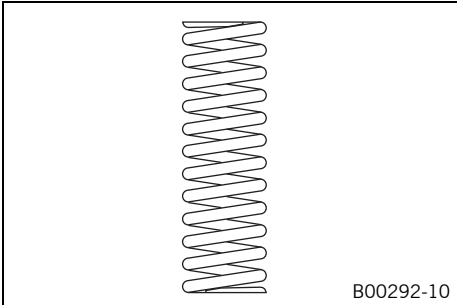

### Preparatory work

- Raise the motorcycle with a lift stand. (📖 p. 42)
- Remove the shock absorber. 🛠️ (📖 p. 50)
- After removing the shock absorber, clean it thoroughly.

### Main work

- Choose and mount a suitable spring.

#### Guideline

|   |                     |
|---|---------------------|
| Spring rate (250 SX EU)                       |                     |
| Weight of rider: 65... 75 kg (143... 165 lb.) | 39 N/mm (223 lb/in) |
| Weight of rider: 75... 85 kg (165... 187 lb.) | 42 N/mm (240 lb/in) |
| Weight of rider: 85... 95 kg (187... 209 lb.) | 45 N/mm (257 lb/in) |
| Spring rate (250 SX US)                       |                     |
| Weight of rider: 65... 75 kg (143... 165 lb.) | 39 N/mm (223 lb/in) |
| Weight of rider: 75... 85 kg (165... 187 lb.) | 42 N/mm (240 lb/in) |
| Weight of rider: 85... 95 kg (187... 209 lb.) | 45 N/mm (257 lb/in) |
| Spring rate (All XC models)                   |                     |
| Weight of rider: 65... 75 kg (143... 165 lb.) | 39 N/mm (223 lb/in) |
| Weight of rider: 75... 85 kg (165... 187 lb.) | 42 N/mm (240 lb/in) |
| Weight of rider: 85... 95 kg (187... 209 lb.) | 45 N/mm (257 lb/in) |



### Info

The spring rate is shown on the outside of the spring.

### Finishing work

- Install the shock absorber. 🛠️ (📖 p. 51)
- Remove the motorcycle from the lift stand. (📖 p. 42)
- Check the static sag of the shock absorber. (📖 p. 35)
- Check the riding sag of the shock absorber. (📖 p. 36)
- Adjust the rebound damping of the shock absorber. (📖 p. 34)

## 10.12 Checking the basic setting of the fork



### Info

For various reasons, no exact riding sag can be determined for the fork.

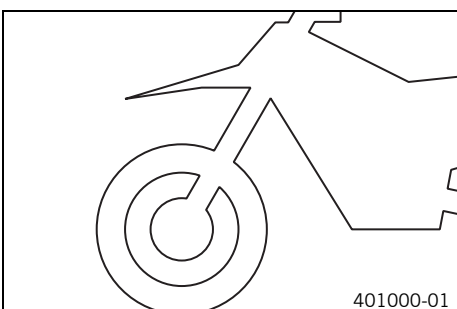

- Smaller differences in the rider's weight can be compensated for by the fork air pressure.
- However, if the fork frequently bottoms out (hard end stop on compression), the fork air pressure must be increased, within the specified values, to avoid damage to the fork and frame.
- If the fork feels unusually hard after extended periods of operation, the fork legs need to be bled.

## 10.13 Adjusting the fork air pressure

**Warning**  
**Danger of accident** Modifications to the suspension setting may seriously alter the handling characteristic. Extreme modifications to the suspension setting may cause a serious deterioration in the handling characteristic and overload components.

- Only make adjustments within the recommended range.
- Ride slowly to start with after making adjustments to get the feel of the new handling characteristic.

**Info**  
 Check or adjust the air pressure under the same conditions at the earliest 5 minutes after switching off the engine. The air suspension is located in the left fork leg. The pressure and rebound damping is located in the right fork leg.

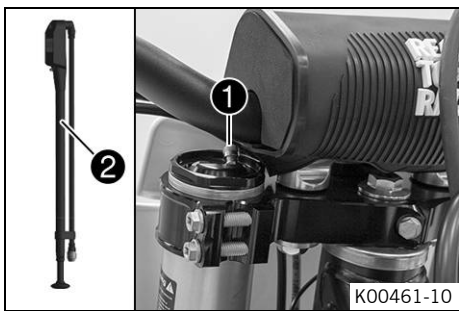

**Preparatory work**

- Raise the motorcycle with a lift stand. (📖 p. 42)

**Main work**

- Remove protection cap ①.
- Push fork pump ② together fully.

Fork pump (79412966000)

**Info**  
 The fork pump is included as part of the motorcycle's separate enclosure.

- Connect the fork pump to the left fork leg.
  - ✓ The fork pump indicator switches on automatically.
  - ✓ A little air escapes from the fork leg when connecting.

**Info**  
 This is due to the volume of the hose and not due to a defect in the fork pump or the fork.  
 Read the accompanying **KTM PowerParts** instructions.

- Adjust the air pressure as specified.

Guideline

|  |                    |
|--|--------------------|
| Air pressure (250 SX EU)                 | 10.3 bar (149 psi) |
| Air pressure (250 SX US)                 | 10.5 bar (152 psi) |
| Air pressure (All XC models)             | 9.4 bar (136 psi)  |
| Changing of the air pressure in steps of | 0.2 bar (3 psi)    |
| Minimum air pressure                     | 7 bar (102 psi)    |
| Maximum air pressure                     | 15 bar (218 psi)   |

**Info**  
 Never set the air pressure to a value outside the stated range.

- Disconnect the fork pump from the left fork leg.
  - ✓ When disconnecting, excess pressure will escape from the hose – the fork leg itself does not lose any air.
  - ✓ The fork pump indicator switches off automatically after 80 seconds.
- Mount the protection cap.

**Finishing work**

- Remove the motorcycle from the lift stand. (📖 p. 42)



## 10.14 Adjusting the compression damping of the fork

**i Info**  
The hydraulic compression damping determines the fork suspension behavior.

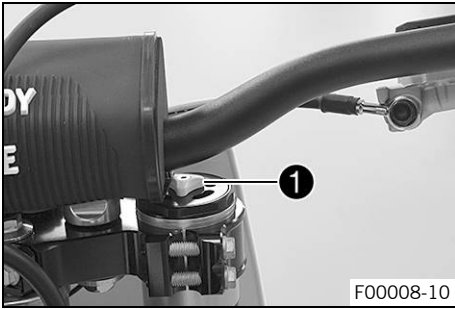

- Turn adjusting screw **1** clockwise all the way.

**i Info**  
Adjusting screw **1** is located at the upper end of the right fork leg.

- Turn counterclockwise by the number of clicks corresponding to the fork type.  
Guideline

|                                     |           |
|-------------------------------------|-----------|
| Compression damping (250 SX EU)     |           |
| Comfort                             | 17 clicks |
| Standard                            | 12 clicks |
| Sport                               | 7 clicks  |
| Compression damping (250 SX US)     |           |
| Comfort                             | 17 clicks |
| Standard                            | 12 clicks |
| Sport                               | 7 clicks  |
| Compression damping (All XC models) |           |
| Comfort                             | 17 clicks |
| Standard                            | 12 clicks |
| Sport                               | 7 clicks  |

**i Info**  
Turn clockwise to increase damping; turn counterclockwise to reduce damping.

## 10.15 Adjusting the rebound damping of the fork

**i Info**  
The hydraulic rebound damping determines the fork suspension behavior.

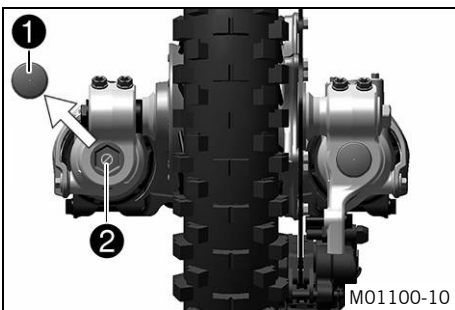

- Remove protection cap **1**.
- Turn adjusting screw **2** clockwise all the way.

**i Info**  
Adjusting screw **2** is located at the lower end of the right fork leg.

- Turn counterclockwise by the number of clicks corresponding to the fork type.  
Guideline

|                                 |           |
|---------------------------------|-----------|
| Rebound damping (250 SX EU)     |           |
| Comfort                         | 17 clicks |
| Standard                        | 12 clicks |
| Sport                           | 7 clicks  |
| Rebound damping (250 SX US)     |           |
| Comfort                         | 17 clicks |
| Standard                        | 12 clicks |
| Sport                           | 7 clicks  |
| Rebound damping (All XC models) |           |
| Comfort                         | 17 clicks |
| Standard                        | 12 clicks |
| Sport                           | 7 clicks  |



**Info**

Turn clockwise to increase damping; turn counterclockwise to reduce damping.

- Mount protection cap ①.

## 10.16 Handlebar position

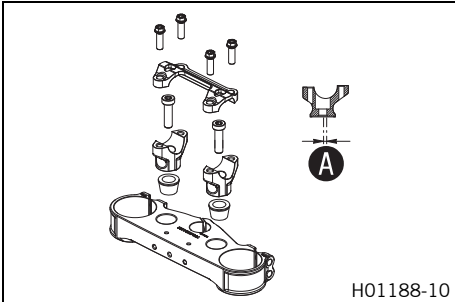

The holes on the handlebar supports are placed at a distance of **A** from the center.

|                 |                   |
|-----------------|-------------------|
| Hole distance A | 3.5 mm (0.138 in) |
|-----------------|-------------------|

The handlebar can be mounted in 2 different positions. In this way, the handlebar can be mounted in the most comfortable position for the rider.

## 10.17 Adjusting the handlebar position ↩



**Warning**

**Danger of accidents** A repaired handlebar poses a safety risk.

If the handlebar is bent or straightened, the material becomes fatigued. The handlebar may break as a result.

- Change the handlebar if the handlebar is damaged or bent.

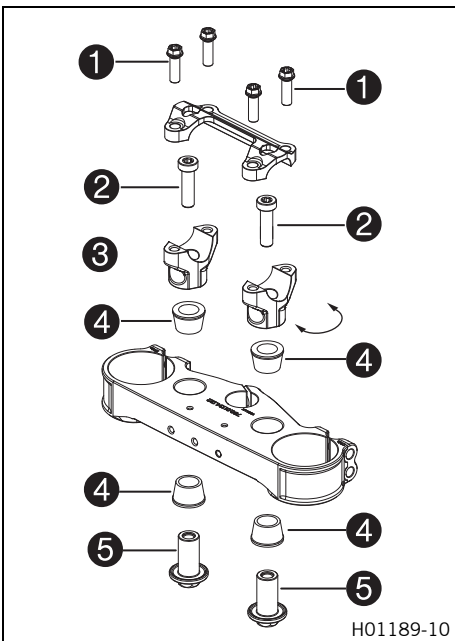

**Preparatory work**

- Remove the handlebar cushion.

**Main work**

- Remove screws ①. Remove the handlebar clamp. Remove the handlebar and lay it to one side.



**Info**

Cover the components to protect them against damage. Do not kink the cables and lines.

- Remove screws ②. Take off handlebar supports ③.
- Position rubber bushings ④ and push through nuts ⑤ from below.
- Place the handlebar supports in the required position.



**Info**

The handlebar supports are longer and higher on one side. Position the left and right handlebar supports evenly.

- Mount and tighten screws ②.

**Guideline**

|                          |     |                        |               |
|--------------------------|-----|------------------------|---------------|
| Screw, handlebar support | M10 | 40 Nm<br>(29.5 lbf ft) | Loctite® 243™ |
|--------------------------|-----|------------------------|---------------|

- Position the handlebar.



**Info**

Make sure the cables and wiring are positioned correctly.

- Position the handlebar clamp.
- Mount screws ① but do not tighten yet.
- First bolt the handlebar clamp with screws ① onto the longer, higher side of the handlebar supports so that both parts touch.

**Guideline**

|                        |    |                        |
|------------------------|----|------------------------|
| Screw, handlebar clamp | M8 | 20 Nm<br>(14.8 lbf ft) |
|------------------------|----|------------------------|

- Tighten screws ❶ evenly.

Guideline

|                        |    |                        |
|------------------------|----|------------------------|
| Screw, handlebar clamp | M8 | 20 Nm<br>(14.8 lbf ft) |
|------------------------|----|------------------------|

### Finishing work

- Mount the handlebar cushion.

## 11.1 Raising the motorcycle with a lift stand

**Note**

**Material damage** The vehicle may be damaged by incorrect procedure when parking. Significant damage may be caused if the vehicle rolls away or falls over. The components for parking the vehicle are designed only for the weight of the vehicle.

- Park the vehicle on a firm and level surface.
- Ensure that nobody sits on the vehicle when the vehicle is parked on a stand.

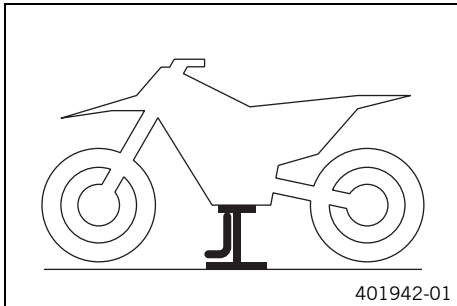

- Raise the motorcycle at the frame underneath the engine.

Lift stand (78129955100)

- ✓ Neither wheel is in contact with the ground.
- Secure the motorcycle against falling over.

## 11.2 Removing the motorcycle from the lift stand

**Note**

**Material damage** The vehicle may be damaged by incorrect procedure when parking. Significant damage may be caused if the vehicle rolls away or falls over. The components for parking the vehicle are designed only for the weight of the vehicle.

- Park the vehicle on a firm and level surface.
- Ensure that nobody sits on the vehicle when the vehicle is parked on a stand.

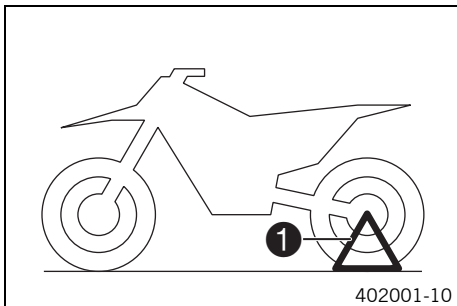

**(All SX models)**

- Remove the motorcycle from the lift stand.
- Remove the lift stand.
- To park the motorcycle, insert plug-in stand ① into the left side of the wheel spindle.

**i Info** Remove the plug-in stand before riding.

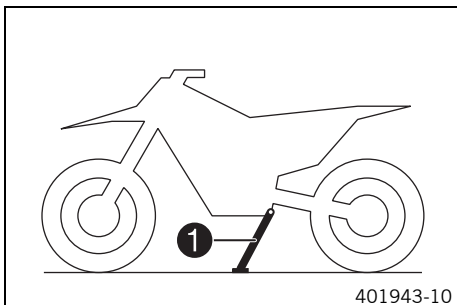

**(All XC models)**

- Remove the motorcycle from the lift stand.
- Remove the lift stand.
- To park the motorcycle, press side stand ① to the ground with your foot and lean the motorcycle on it.

**i Info** While riding, the side stand must be folded up and secured with the rubber band.

## 11.3 Bleeding the fork legs

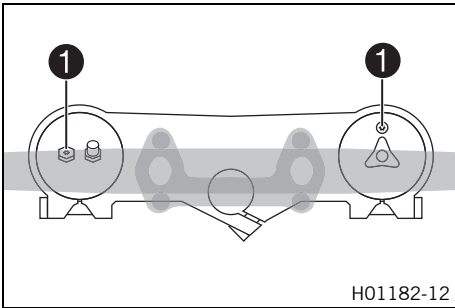

### Preparatory work

- Raise the motorcycle with a lift stand. (📖 p. 42)

### Main work

- Release bleeder screws ❶.
- ✓ Any excess pressure escapes from the interior of the fork.
- Tighten the bleeder screws.

### Finishing work

- Remove the motorcycle from the lift stand. (📖 p. 42)

## 11.4 Cleaning the dust boots of the fork legs

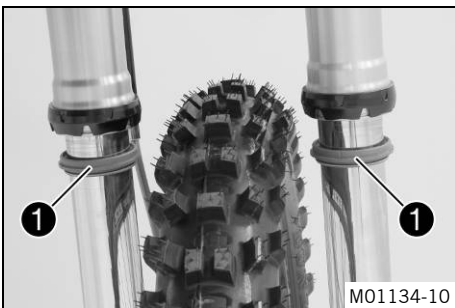

### Preparatory work

- Raise the motorcycle with a lift stand. (📖 p. 42)
- Remove the fork protector. (📖 p. 44)

### Main work

- Push dust boots ❶ of both fork legs downward.



### Info

The dust boots remove dust and coarse dirt particles from the inside fork tubes. Over time, dirt can accumulate behind the dust boots. If this dirt is not removed, the oil seals behind can start to leak.



### Warning

**Danger of accidents** Oil or grease on the brake discs reduces the braking effect.

- Always keep the brake discs free of oil and grease.
- Clean the brake discs with brake cleaner when necessary.

- Clean and oil the dust boots and inner fork tubes of both fork legs.

Universal oil spray (📖 p. 122)

- Press the dust boots back into their normal position.
- Remove excess oil.

### Finishing work

- Install the fork protector. (📖 p. 45)
- Remove the motorcycle from the lift stand. (📖 p. 42)

## 11.5 Removing the fork legs ↘

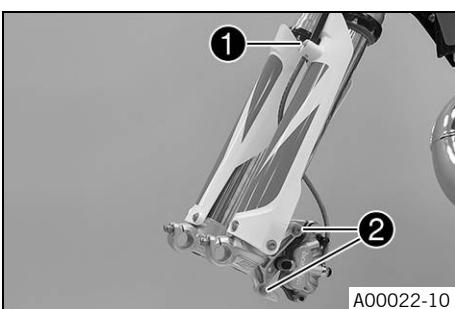

### Preparatory work

- Raise the motorcycle with a lift stand. (📖 p. 42)
- Remove the front wheel. ↘ (📖 p. 76)

### Main work

- Remove screws ❶ and take off the clamp.
- Remove screws ❷ and take off the brake caliper.
- Allow the brake caliper and brake line to hang tension-free to the side.



### Info

Do not activate the hand brake lever while the front wheel is removed.

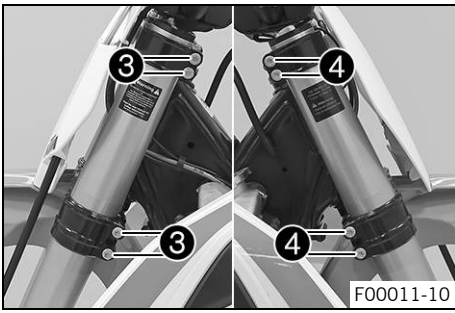

- Unscrew screws ③. Take out the left fork leg.
- Unscrew screws ④. Take out the right fork leg.

## 11.6 Installing the fork legs

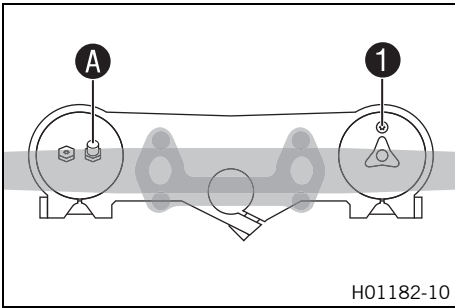

### Main work

- Position the fork legs.
- ✓ Bleeder screw ① of the right fork leg is positioned to the front.
- ✓ Valve A of the left fork leg faces the front.

### Info

Grooves are milled into the side of the upper end of the fork legs. The second milled groove (from the top) must be flush with the top edge of the upper triple clamp.

The air suspension is located in the left fork leg. The pressure and rebound damping is located in the right fork leg.

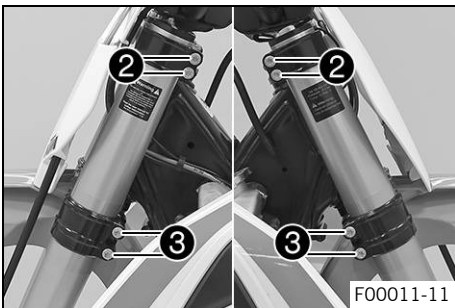

- Tighten screws ②.

### Guideline

|                         |    |                        |
|-------------------------|----|------------------------|
| Screw, top triple clamp | M8 | 17 Nm<br>(12.5 lbf ft) |
|-------------------------|----|------------------------|

- Tighten screws ③.

### Guideline

|                            |    |                    |
|----------------------------|----|--------------------|
| Screw, bottom triple clamp | M8 | 12 Nm (8.9 lbf ft) |
|----------------------------|----|--------------------|

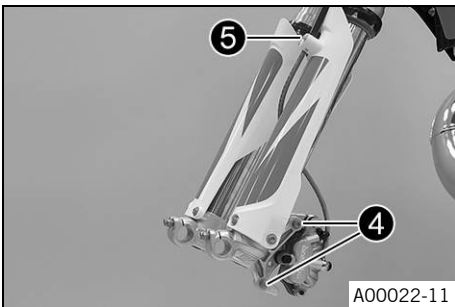

- Position the brake caliper. Mount and tighten screws ④.

### Guideline

|                            |    |                        |               |
|----------------------------|----|------------------------|---------------|
| Screw, front brake caliper | M8 | 25 Nm<br>(18.4 lbf ft) | Loctite® 243™ |
|----------------------------|----|------------------------|---------------|

- Position the brake line and clamp. Mount and tighten screws ⑤.

### Finishing work

- Install the front wheel. (🔧 p. 76)

## 11.7 Removing the fork protector

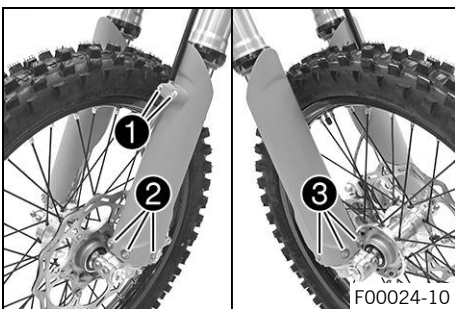

- Remove screws ①. Remove the clamp.
- Remove screws ②. Take off the left fork protector.
- Remove screws ③. Take off the right fork protector.

## 11.8 Installing the fork protector

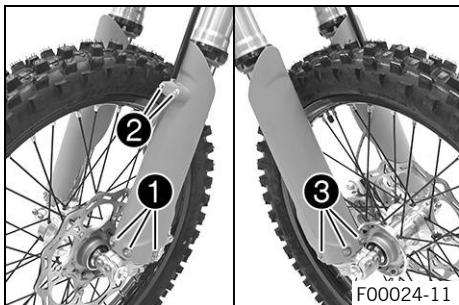

- Position the fork protection on the left fork leg. Mount and tighten screws ❶.

Guideline

|                           |    |                    |
|---------------------------|----|--------------------|
| Remaining screws, chassis | M6 | 10 Nm (7.4 lbf ft) |
|---------------------------|----|--------------------|

- Position the brake line and clamp. Mount and tighten screws ❷.
- Position the fork protector on the right fork leg. Mount and tighten screws ❸.

Guideline

|                           |    |                    |
|---------------------------|----|--------------------|
| Remaining screws, chassis | M6 | 10 Nm (7.4 lbf ft) |
|---------------------------|----|--------------------|

## 11.9 Removing the lower triple clamp

### Preparatory work

- Raise the motorcycle with a lift stand. (📖 p. 42)
- Remove the front wheel. 🛠️ (📖 p. 76)
- Remove the fork legs. 🛠️ (📖 p. 43)
- Remove the start number plate. (📖 p. 49)
- Remove the front fender. (📖 p. 49)
- Remove the handlebar cushion.

### Main work

- Remove screw ❶.
- Remove screw ❷.
- Pull off the upper triple clamp with the handlebar and hang to the side.



### Info

Protect the components against damage by covering them. Do not kink the cables and lines.

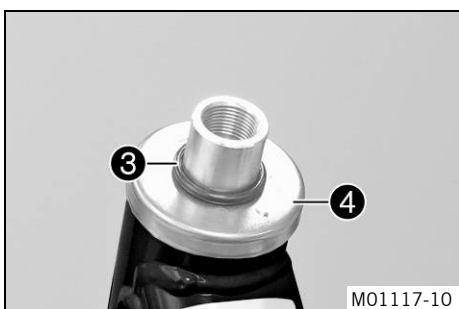
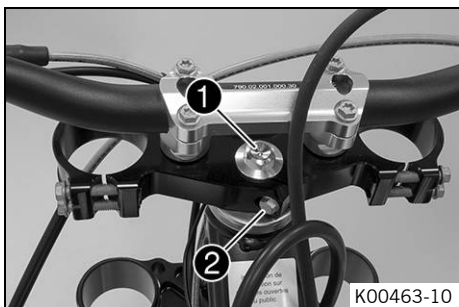

- Remove O-ring ❸. Remove protective ring ❹.
- Take off the lower triple clamp with the steering stem.
- Remove the upper steering head bearing.

## 11.10 Installing the lower triple clamp

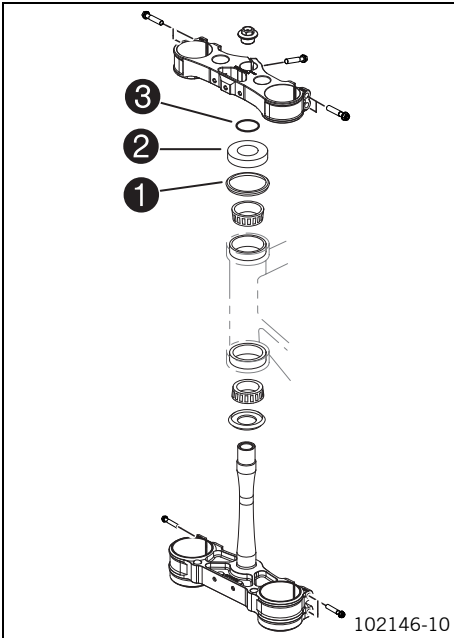

### Main work

- Clean the bearing and sealing elements, check for damage, and grease.

High viscosity grease (📖 p. 121)

- Insert the lower triple clamp with the steering stem. Mount the upper steering head bearing.
- Check whether upper steering head seal **1** is correctly positioned.
- Slide on protective ring **2** and O-ring **3**.

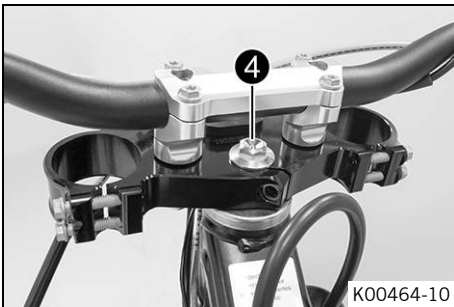

- Position the upper triple clamp with the handlebar.
- Mount screw **4** but do not tighten yet.

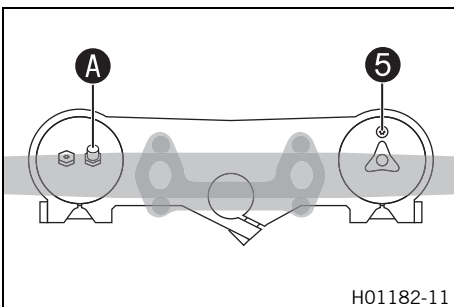

- Position the fork legs.
  - ✓ Bleeder screw **5** of the right fork leg is positioned to the front.
  - ✓ Valve **A** of the left fork leg faces the front.

### Info

The air suspension **AER** valve is located in the left fork leg. Grooves are milled into the side of the upper end of the fork legs. The second milled groove (from the top) must be flush with the top edge of the upper triple clamp.

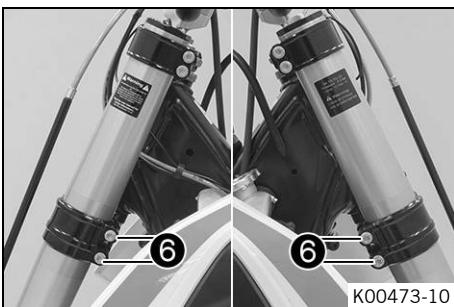

- Tighten screws **6**.

### Guideline

|                            |    |                    |
|----------------------------|----|--------------------|
| Screw, bottom triple clamp | M8 | 12 Nm (8.9 lbf ft) |
|----------------------------|----|--------------------|

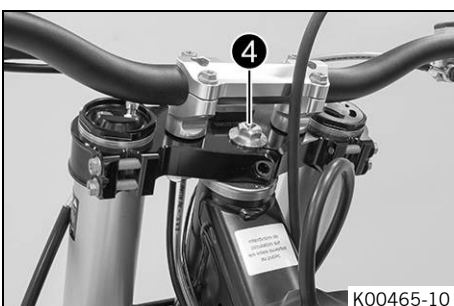

- Tighten screw **4**.

### Guideline

|                          |         |                    |
|--------------------------|---------|--------------------|
| Screw, top steering head | M20x1.5 | 12 Nm (8.9 lbf ft) |
|--------------------------|---------|--------------------|





- Mount and tighten screw 7.

Guideline

|                          |    |                        |               |
|--------------------------|----|------------------------|---------------|
| Screw, top steering stem | M8 | 20 Nm<br>(14.8 lbf ft) | Loctite® 243™ |
|--------------------------|----|------------------------|---------------|

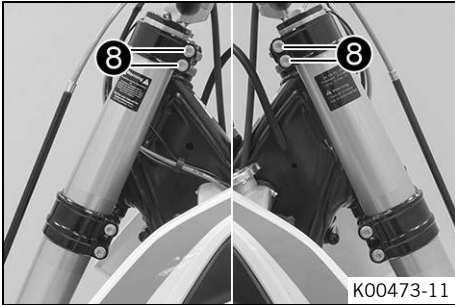

- Tighten screws 8.

Guideline

|                         |    |                        |  |
|-------------------------|----|------------------------|--|
| Screw, top triple clamp | M8 | 17 Nm<br>(12.5 lbf ft) |  |
|-------------------------|----|------------------------|--|

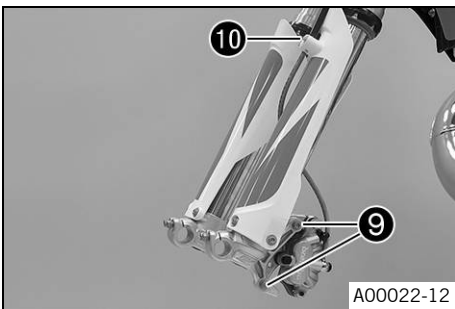

- Position the brake caliper. Mount and tighten screws 9.

Guideline

|                            |    |                        |               |
|----------------------------|----|------------------------|---------------|
| Screw, front brake caliper | M8 | 25 Nm<br>(18.4 lbf ft) | Loctite® 243™ |
|----------------------------|----|------------------------|---------------|

- Position the brake line and clamp. Mount and tighten screws 10.

### Finishing work

- Check that the wiring harness, throttle cables, and brake and clutch lines can move freely and are routed correctly.
- Install the front fender. (📖 p. 49)
- Install the front wheel. 🛠️ (📖 p. 76)
- Check the play of the steering head bearing. (📖 p. 47)
- Remove the motorcycle from the lift stand. (📖 p. 42)
- Install the start number plate. (📖 p. 49)
- Mount the handlebar cushion.

## 11.11 Checking the play of the steering head bearing

**Warning**  
**Danger of accidents** Incorrect steering head bearing play impairs the handling characteristic and damages components.  
 - Correct incorrect steering head bearing play immediately. (Your authorized KTM workshop will be glad to help.)

**Info**  
 If the vehicle is operated for a lengthy period with play in the steering head bearing, the bearings and the bearing seats in the frame can become damaged over time.

### Preparatory work

- Raise the motorcycle with a lift stand. (📖 p. 42)

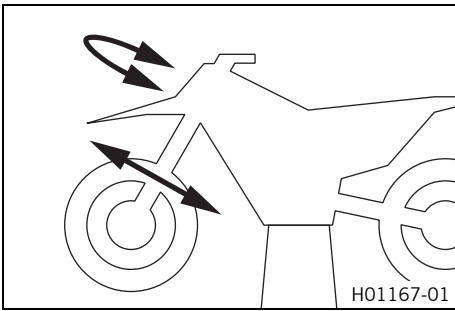

**Main work**

- Move the handlebar to the straight-ahead position. Move the fork legs to and fro in the direction of travel.

Play should not be detectable on the steering head bearing.

- » If there is detectable play:
  - Adjust the steering head bearing play. (🔧 p. 48)

- Move the handlebar to and fro over the entire steering range.

It must be possible to move the handlebar easily over the entire steering range. There should be no detectable detent positions.

- » If detent positions are detected:
  - Adjust the steering head bearing play. (🔧 p. 48)
  - Check the steering head bearing and change if necessary.

**Finishing work**

- Remove the motorcycle from the lift stand. (🔧 p. 42)

**11.12 Adjusting the steering head bearing play 🛠️**

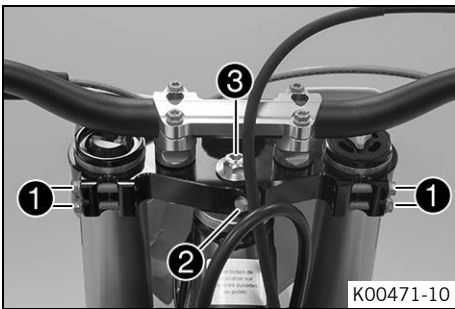

**Preparatory work**

- Raise the motorcycle with a lift stand. (🔧 p. 42)
- Remove the handlebar cushion.

**Main work**

- Loosen screws ❶.
- Remove screw ❷.
- Loosen and retighten screw ❸.

**Guideline**

|                          |         |                    |
|--------------------------|---------|--------------------|
| Screw, top steering head | M20x1.5 | 12 Nm (8.9 lbf ft) |
|--------------------------|---------|--------------------|

- Using a plastic hammer, tap lightly on the upper triple clamp to avoid stresses.
- Tighten screws ❶.

**Guideline**

|                         |    |                     |
|-------------------------|----|---------------------|
| Screw, top triple clamp | M8 | 17 Nm (12.5 lbf ft) |
|-------------------------|----|---------------------|

- Mount and tighten screw ❷.

**Guideline**

|                          |    |                     |                      |
|--------------------------|----|---------------------|----------------------|
| Screw, top steering stem | M8 | 20 Nm (14.8 lbf ft) | <b>Loctite® 243™</b> |
|--------------------------|----|---------------------|----------------------|

**Finishing work**

- Check the play of the steering head bearing. (🔧 p. 47)
- Remove the motorcycle from the lift stand. (🔧 p. 42)
- Mount the handlebar cushion.

**11.13 Greasing the steering head bearing 🛠️**

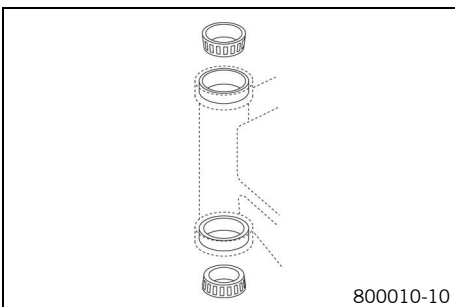

- Remove the lower triple clamp. 🛠️ (🔧 p. 45)
- Install the lower triple clamp. 🛠️ (🔧 p. 46)

## 11.14 Removing the start number plate



- Remove screw ❶.
- Disconnect the brake line at the start number plate. Take off the start number plate.

## 11.15 Installing the start number plate

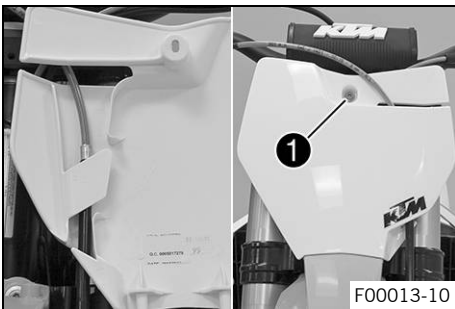

- Connect the brake line at the start number plate.
- Position the start number plate.
- ✓ The holding lugs engage in the fender.
- Mount and tighten screw ❶.

## 11.16 Removing the front fender

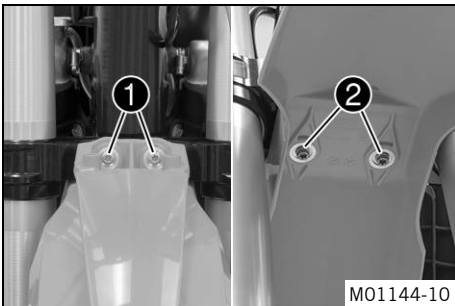

### Preparatory work

- Remove the start number plate. (📖 p. 49)

### Main work

- Remove screws ❶ and ❷. Remove the front fender.

## 11.17 Installing the front fender

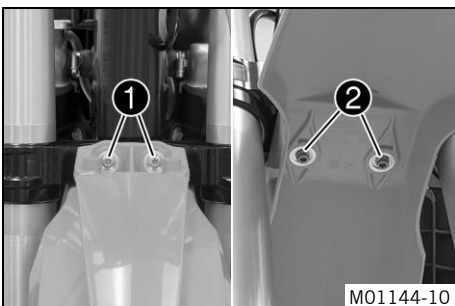

### Main work

- Position the front fender. Mount and tighten screws ❶ and ❷.

### Guideline

|                           |    |                    |
|---------------------------|----|--------------------|
| Remaining screws, chassis | M6 | 10 Nm (7.4 lbf ft) |
|---------------------------|----|--------------------|

### Finishing work

- Install the start number plate. (📖 p. 49)

## 11.18 Removing the shock absorber

### Preparatory work

- Raise the motorcycle with a lift stand. (📖 p. 42)

### Main work

- Remove screws ① with the washers and remove screws ②.
- Remove the cable ties and remove the frame protectors on the left and right.

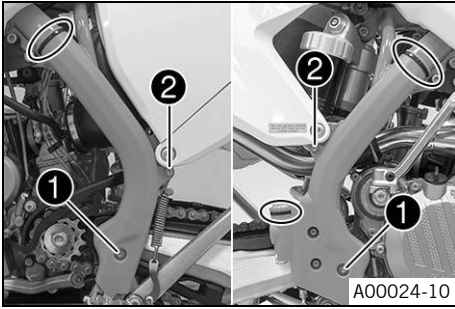

A00024-10

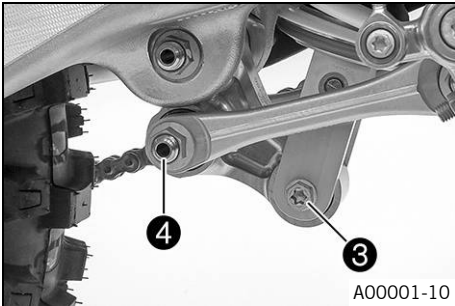

A00001-10

- Remove screw ③.
- Remove fitting ④.

### **i** Info

Raise the wheel slightly to be able to remove the screws more easily.

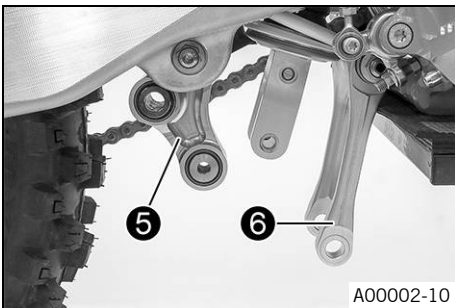

A00002-10

- Press angle lever ⑤ toward the rear.
- Press linkage lever ⑥ downward.

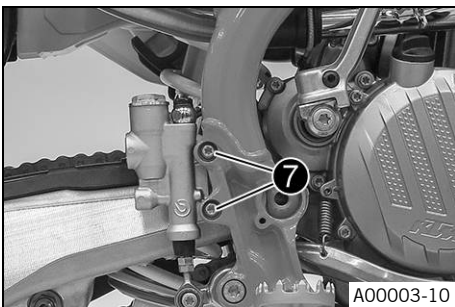

A00003-10

- Remove screws ⑦ and pull foot brake cylinder off the push rod.

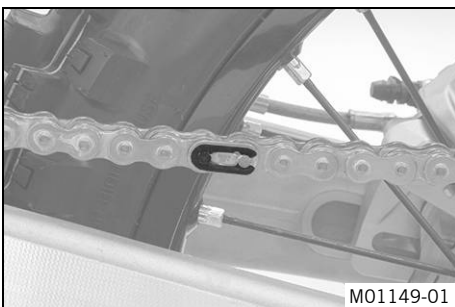

M01149-01

- Remove the connecting link of the chain.
- Take off the chain.

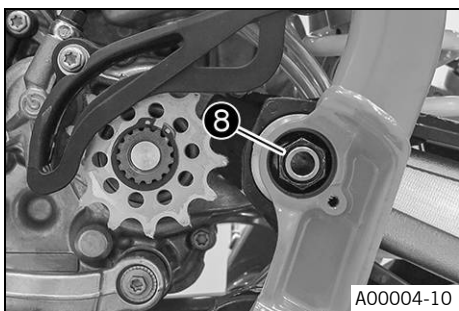

- Remove nut **8** and pull out the swingarm pivot.
- Push the swingarm back and secure it against falling over.



- Hold the shock absorber and remove screw **9**.

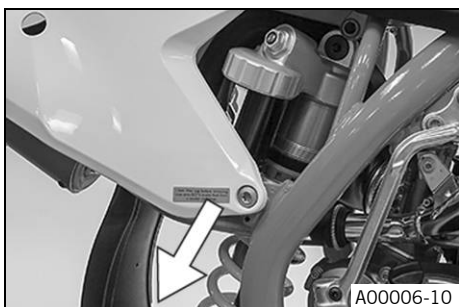

- Remove the shock absorber carefully at the bottom.

## 11.19 Installing the shock absorber

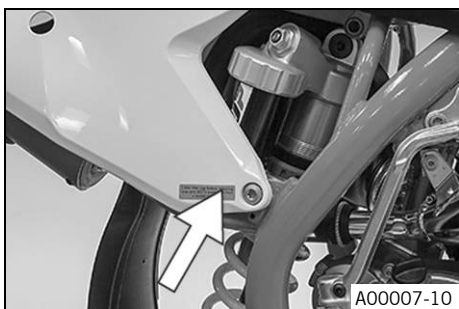

### Main work

- Carefully position the shock absorber into the vehicle from the bottom.



- Mount and tighten screw **1**.

### Guideline

|                           |     |                        |                |
|---------------------------|-----|------------------------|----------------|
| Screw, top shock absorber | M10 | 60 Nm<br>(44.3 lbf ft) | Loctite® 2701™ |
|---------------------------|-----|------------------------|----------------|

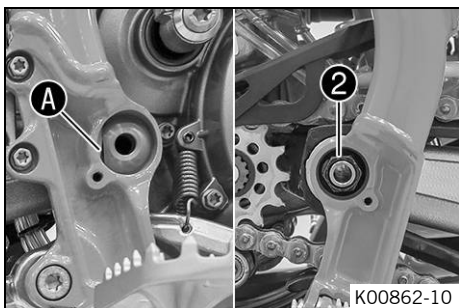

- Position the swingarm and mount the swingarm pivot.

**i Info**  
Pay attention to flat area **A**.

- Mount and tighten nut **2**.

### Guideline

|                     |         |                         |
|---------------------|---------|-------------------------|
| Nut, swingarm pivot | M16x1.5 | 100 Nm<br>(73.8 lbf ft) |
|---------------------|---------|-------------------------|

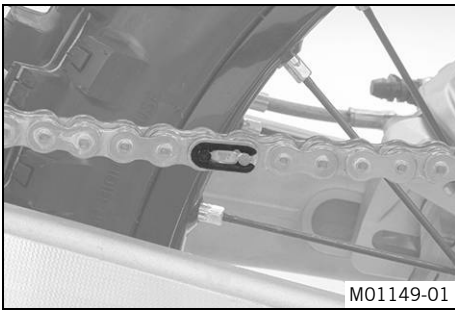

- Mount the chain.
- Connect the chain with the connecting link.

Guideline

The closed side of the chain joint lock must face in the direction of travel.

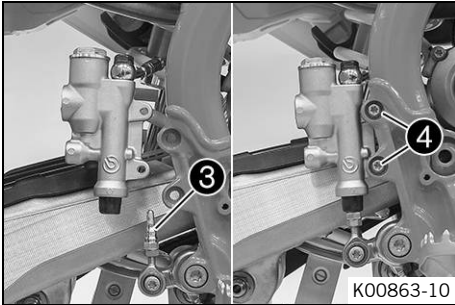

- Position the foot brake cylinder.
  - ✓ Push rod **3** engages in the foot brake cylinder.
  - ✓ The dust boot is correctly positioned.
- Mount and tighten screws **4**.

Guideline

|                           |    |                    |
|---------------------------|----|--------------------|
| Remaining screws, chassis | M6 | 10 Nm (7.4 lbf ft) |
|---------------------------|----|--------------------|

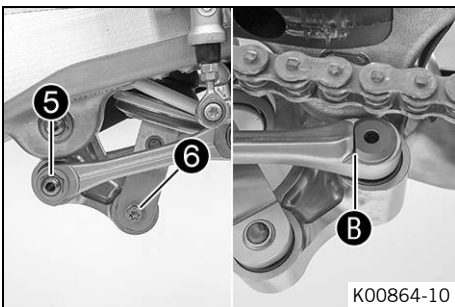

- Position the angle lever and linkage lever.
- Mount and tighten fitting **5**.

Guideline

|                                   |         |                   |
|-----------------------------------|---------|-------------------|
| Nut, linkage lever to angle lever | M14x1.5 | 80 Nm (59 lbf ft) |
|-----------------------------------|---------|-------------------|

**i** **Info**  
Pay attention to flat area **B**.

- Mount and tighten screw **6**.

Guideline

|                              |     |                     |                       |
|------------------------------|-----|---------------------|-----------------------|
| Screw, bottom shock absorber | M10 | 60 Nm (44.3 lbf ft) | <b>Loctite® 2701™</b> |
|------------------------------|-----|---------------------|-----------------------|

**i** **Info**  
Raise the wheel slightly to be able to mount the screw more easily.

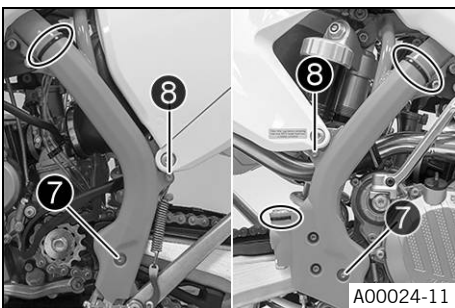

- Position the frame protectors on the left and right.
- Mount and tighten screws **7** with the washers and mount and tighten screws **8**.

Guideline

|                        |    |                   |
|------------------------|----|-------------------|
| Screw, frame protector | M5 | 3 Nm (2.2 lbf ft) |
|------------------------|----|-------------------|

- Mount the cable tie(s).

**Finishing work**

- Remove the motorcycle from the lift stand. (📖 p. 42)

## 11.20 Removing the seat

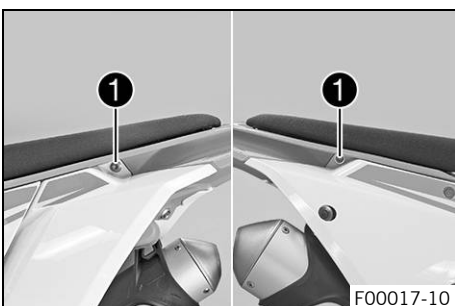

- Remove screws **1**.
- Raise the rear of the seat, pull the seat back, and lift it off.

## 11.21 Mounting the seat

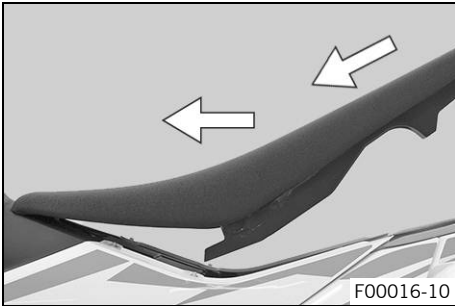

- Mount the front of the seat on the collar bushing of the fuel tank, lower the seat at the rear, and push the seat forward.
- Make sure that the seat is correctly locked in.

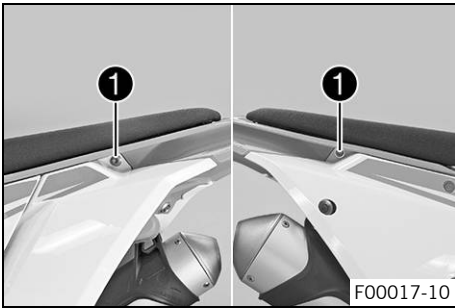

- Mount and tighten screws ①.

Guideline

|                           |    |                    |
|---------------------------|----|--------------------|
| Remaining screws, chassis | M6 | 10 Nm (7.4 lbf ft) |
|---------------------------|----|--------------------|

## 11.22 Removing the air filter box cover



### Condition

The air filter box cover is secured.

- Remove screw ①.

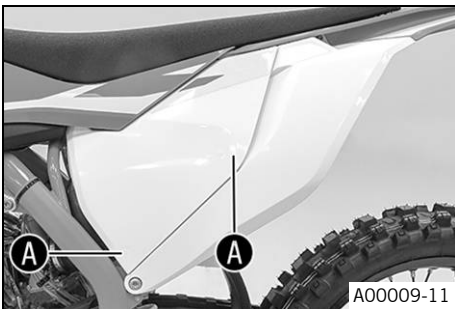

- Pull off the air filter box cover in area A sideways and remove it toward the front.

## 11.23 Installing the air filter box cover

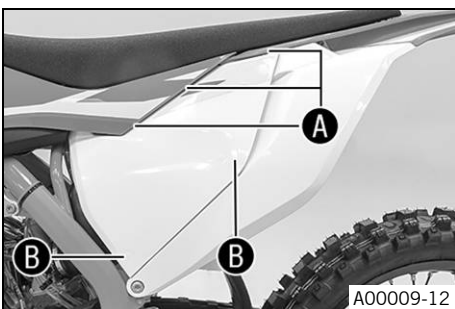

- Insert the air filter box cover in area A and clip it into area B.

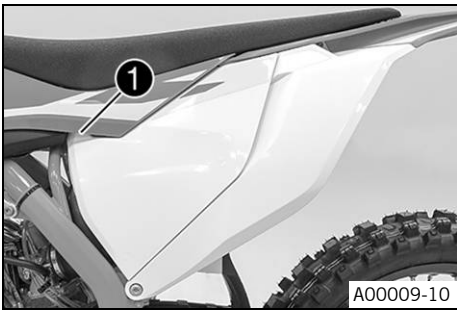

**Condition**

The air filter box cover is secured.

- Mount and tighten screw ①.

**Guideline**

|                             |                             |                      |                               |
|-----------------------------|-----------------------------|----------------------|-------------------------------|
| Screw, air filter box cover | <b>EJOT PT®</b><br>K60x20-Z | 3 Nm<br>(2.2 lbf ft) | EJOT PT screw<br>(0017060204) |
|-----------------------------|-----------------------------|----------------------|-------------------------------|

## 11.24 Removing the air filter ↩

**Note**

**Engine damage** Unfiltered intake air has a negative effect on the service life of the engine.

Dust and dirt will enter the engine without an air filter.

- Never start to use the vehicle without an air filter.

 **Warning**

**Environmental hazard** Hazardous substances cause environmental damage.

- Dispose of oils, grease, filters, fuel, cleaning agents, brake fluid, etc., correctly and in compliance with the applicable regulations.

**Preparatory work**

- Remove the air filter box cover. (📖 p. 53)

**Main work**

- Detach retaining tab ①. Remove air filter with air filter support.
- Take off air filter from air filter support.

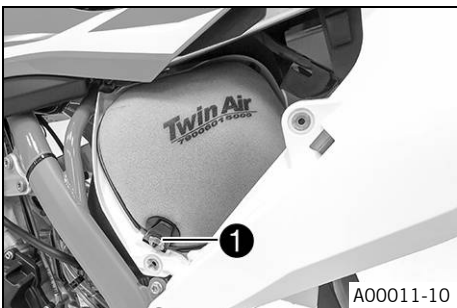

## 11.25 Cleaning the air filter and air filter box ↩

 **Warning**

**Environmental hazard** Hazardous substances cause environmental damage.

- Dispose of oils, grease, filters, fuel, cleaning agents, brake fluid, etc., correctly and in compliance with the applicable regulations.

 **Info**

Do not clean the air filter with fuel or petroleum since these substances attack the foam.

**Preparatory work**

- Remove the air filter box cover. (📖 p. 53)
- Remove the air filter. (🔧 p. 54)

**Main work**

- Wash the air filter thoroughly in special cleaning liquid and allow it to dry properly.

|                               |
|-------------------------------|
| Air filter cleaner (📖 p. 121) |
|-------------------------------|

 **Info**

Only squeeze the air filter to dry it; never wring it out.

- Oil the dry air filter with a high quality filter oil.

|                                    |
|------------------------------------|
| Oil for foam air filter (📖 p. 121) |
|------------------------------------|



K00518-01



- Clean the air filter box.
- Clean the intake flange and check it for damage and tightness.

**Finishing work**

- Install the air filter. (📖 p. 55)
- Install the air filter box cover. (📖 p. 53)

## 11.26 Installing the air filter 🛠️

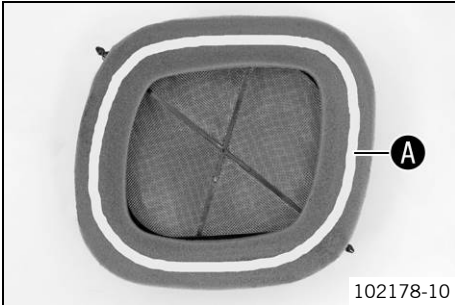

102178-10

**Main work**

- Mount the clean air filter on the air filter support.
- Grease the air filter in area **A**.

|                             |
|-----------------------------|
| Long-life grease (📖 p. 121) |
|-----------------------------|

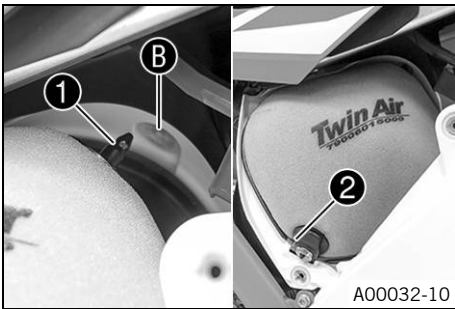

A00032-10

- Insert the air filter and position the top retaining pin **1** in bushing **B**.  
✓ The air filter is correctly positioned.
- Secure the bottom retaining pin with holding tab **2**.

**i Info**

If the air filter is not mounted correctly, dust and dirt may enter the engine and result in damage.

**Finishing work**

- Install the air filter box cover. (📖 p. 53)

## 11.27 Securing the air filter box cover 🛠️

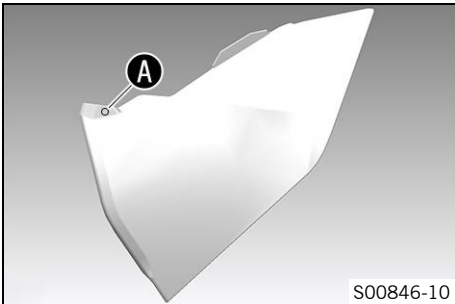

S00846-10

**Preparatory work**

- Remove the air filter box cover. (📖 p. 53)

**Main work**

- Drill a hole at marking **A**.

Guideline

|          |                |
|----------|----------------|
| Diameter | 6 mm (0.24 in) |
|----------|----------------|

**Finishing work**

- Install the air filter box cover. (📖 p. 53)

## 11.28 Sealing the air filter box 🛠️

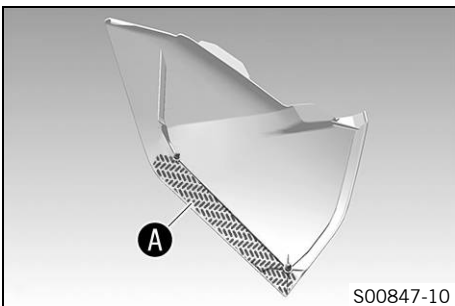

S00847-10

**Preparatory work**

- Remove the air filter box cover. (📖 p. 53)

**Main work**

- Seal the air filter box in marked area **A**.

**Finishing work**

- Install the air filter box cover. (📖 p. 53)

## 11.29 Removing the main silencer

**Warning**  
**Danger of burns** The exhaust system gets very hot when the vehicle is driven.

- Allow the exhaust system to cool down before performing any work on the vehicle.

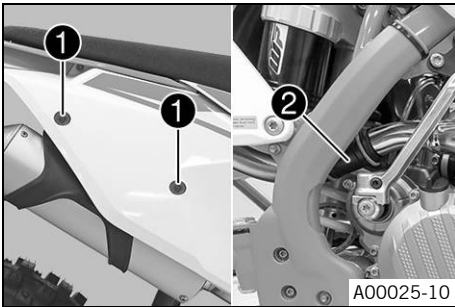

- Remove screws ① with the washers.
- Pull off the main silencer from the manifold at rubber sleeve ②.

## 11.30 Installing the main silencer

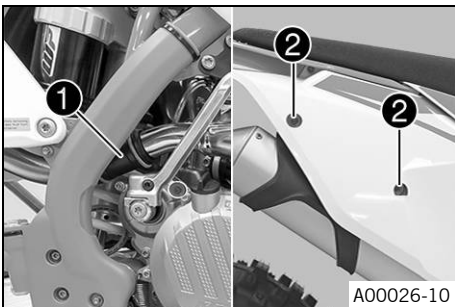

- Position the main silencer with rubber sleeve ①.
- Mount and tighten screws ② with the washers.

Guideline

|                           |    |                    |
|---------------------------|----|--------------------|
| Remaining screws, chassis | M6 | 10 Nm (7.4 lbf ft) |
|---------------------------|----|--------------------|

## 11.31 Changing the glass fiber yarn filling in the main silencer ↴

**Warning**  
**Danger of burns** The exhaust system gets very hot when the vehicle is driven.

- Allow the exhaust system to cool down before performing any work on the vehicle.

**i Info**  
 Over time, the fibers of the glass fiber yarn escape and the damper "burns" out. Not only is the noise level higher, the performance characteristic changes.

### Preparatory work

- Remove the main silencer. (📖 p. 56)

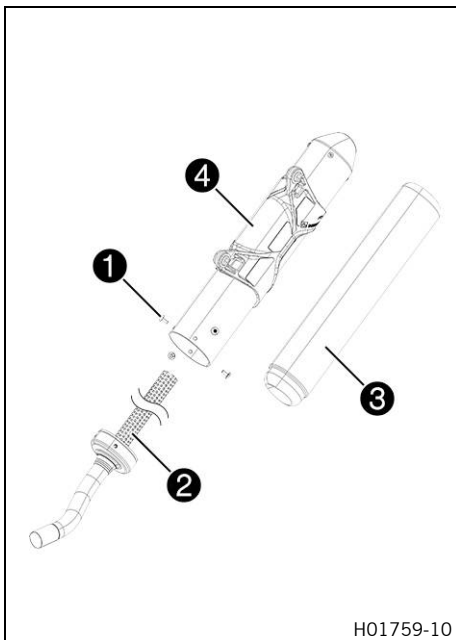

### Main work

- Remove screws ❶. Pull out inner tube ❷.
- Remove the glass fiber yarn filling ❸ from the inner tube.
- Clean the parts that need to be reinstalled and check for damage.
- Fit the new glass fiber yarn filling ❸ into the inner tube.
- Slide outer tube ❹ over the inner tube with the new glass fiber yarn filling.
- Mount and tighten all screws ❶.

### Guideline

|                             |    |                   |
|-----------------------------|----|-------------------|
| Screws on the main silencer | M5 | 7 Nm (5.2 lbf ft) |
|-----------------------------|----|-------------------|

### Finishing work

- Install the main silencer. (📖 p. 56)

## 11.32 Removing the fuel tank 🐘



### Danger

**Fire hazard** Fuel is highly flammable.

The fuel in the fuel tank expands when warm and can escape if overfilled.

- Do not refuel the vehicle in the vicinity of open flames or lit cigarettes.
- Switch off the engine for refueling.
- Make sure that no fuel is spilled; particularly not on hot parts of the vehicle.
- If any fuel is spilled, wipe it off immediately.
- Observe the specifications for refueling.



### Warning

**Danger of poisoning** Fuel is poisonous and a health hazard.

- Avoid skin, eye and clothing contact with fuel.
- Immediately consult a doctor if you swallow fuel.
- Do not inhale fuel vapors.
- In case of skin contact, rinse the affected area with plenty of water.
- Rinse the eyes thoroughly with water, and consult a doctor in case of fuel contact with the eyes.
- Change your clothing in case of fuel spills on them.
- Keep fuels correctly in a suitable canister, and out of the reach of children.

### Preparatory work

- Remove the seat. (📖 p. 52)

#### (All SX models)

- Turn handle ❶ of the fuel tap to the **OFF** position. (Figure A00016-10📖 p. 15)

#### (All XC models)

- Turn handle ❶ of the fuel tap to the **OFF** position. (Figure A00023-10📖 p. 15)

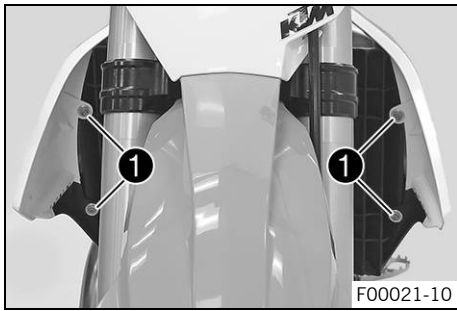

**Main work**

- Pull off the fuel hose.



**Info**

Remaining fuel may flow out of the fuel hose.

- Remove screws 1.

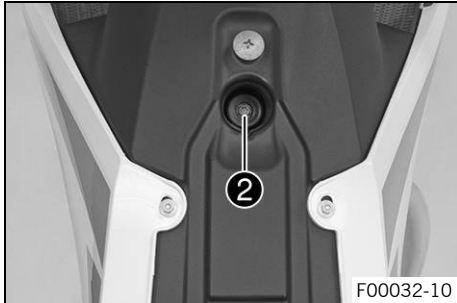

**(All SX models)**

- Remove screw 2 with the rubber bushing.
- Pull the fuel tank breather hose off the tank lid.

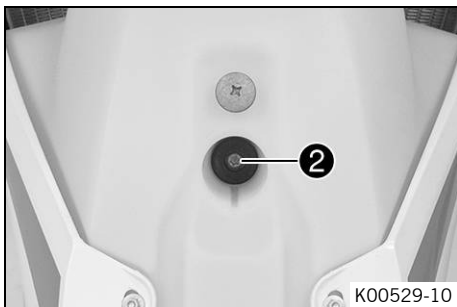

**(All XC models)**

- Remove screw 2 with the rubber bushing.
- Pull the fuel tank breather hose off the tank lid.

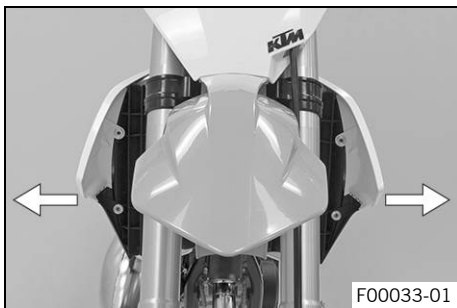

- Pull both spoilers off the sides of the radiator bracket and lift off the fuel tank.

## 11.33 Installing the fuel tank



**Danger**

**Fire hazard** Fuel is highly flammable.

The fuel in the fuel tank expands when warm and can escape if overfilled.

- Do not refuel the vehicle in the vicinity of open flames or lit cigarettes.
- Switch off the engine for refueling.
- Make sure that no fuel is spilled; particularly not on hot parts of the vehicle.
- If any fuel is spilled, wipe it off immediately.
- Observe the specifications for refueling.



**Warning**

**Danger of poisoning** Fuel is poisonous and a health hazard.

- Avoid skin, eye and clothing contact with fuel.
- Immediately consult a doctor if you swallow fuel.
- Do not inhale fuel vapors.
- In case of skin contact, rinse the affected area with plenty of water.
- Rinse the eyes thoroughly with water, and consult a doctor in case of fuel contact with the eyes.
- Change your clothing in case of fuel spills on them.

### Main work

- Check the throttle cable routing. (📖 p. 63)
- Position the fuel tank and fit the two spoilers to the sides of the radiator bracket.
- Make sure that no cables or throttle cables are trapped or damaged.

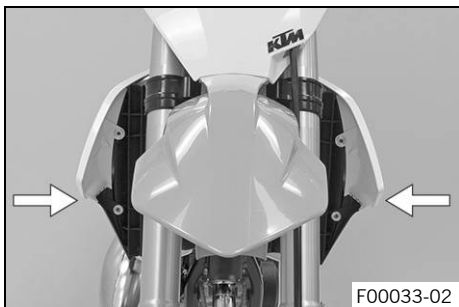

### (All SX models)

- Mount the fuel tank breather hose.
- Mount and tighten screw **1** with the rubber bushing.

#### Guideline

|                           |    |                       |
|---------------------------|----|-----------------------|
| Remaining screws, chassis | M6 | 10 Nm<br>(7.4 lbf ft) |
|---------------------------|----|-----------------------|



### (All XC models)

- Mount the fuel tank breather hose.
- Mount and tighten screw **1** with the rubber bushing.

#### Guideline

|                           |    |                       |
|---------------------------|----|-----------------------|
| Remaining screws, chassis | M6 | 10 Nm<br>(7.4 lbf ft) |
|---------------------------|----|-----------------------|

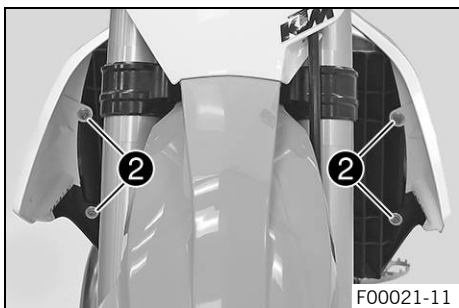

- Mount and tighten screws **2**.

#### Guideline

|                           |    |                    |
|---------------------------|----|--------------------|
| Remaining screws, chassis | M6 | 10 Nm (7.4 lbf ft) |
|---------------------------|----|--------------------|

- Connect the fuel hose.

### Finishing work

- Mount the seat. (📖 p. 53)

## 11.34 Checking the chain for dirt

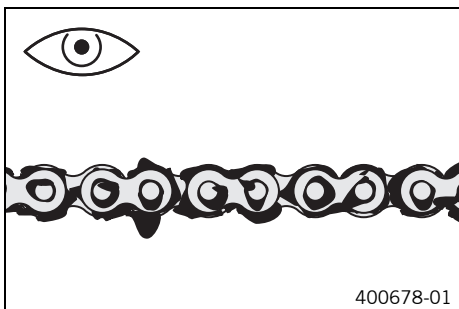

- Check the chain for heavy soiling.
  - » If the chain is very dirty:
    - Clean the chain. (📖 p. 60)

## 11.35 Cleaning the chain

**Warning**  
**Danger of accidents** Oil or grease on the tires reduces the road grip.

- Remove the lubricant from the tires using a suitable cleaning agent.

**Warning**  
**Danger of accidents** Oil or grease on the brake discs reduces the braking effect.

- Always keep the brake discs free of oil and grease.
- Clean the brake discs with brake cleaner when necessary.

**Warning**  
**Environmental hazard** Hazardous substances cause environmental damage.

- Dispose of oils, grease, filters, fuel, cleaning agents, brake fluid, etc., correctly and in compliance with the applicable regulations.

**Info**  
 The service life of the chain depends largely on its maintenance.

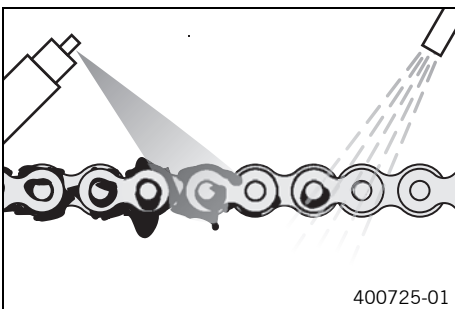

**Preparatory work**

- Raise the motorcycle with a lift stand. (🔧 p. 42)

**Main work**

- Rinse off loose dirt with a soft jet of water.
- Remove old grease residue with chain cleaner.

Chain cleaner (🔧 p. 121)

- After drying, apply chain spray.

Off-road chain spray (🔧 p. 121)

**Finishing work**

- Remove the motorcycle from the lift stand. (🔧 p. 42)

## 11.36 Checking the chain tension

**Warning**  
**Danger of accidents** Incorrect chain tension damages components and results in accidents.

If the chain is tensioned too much, the chain, engine sprocket, rear sprocket, transmission and rear wheel bearings wear more quickly. Some components may break if overloaded.

If the chain is too loose, the chain may fall off the engine sprocket or the rear sprocket. As a result, the rear wheel locks or the engine will be damaged.

- Check the chain tension regularly.
- Set the chain tension in accordance with the specification.

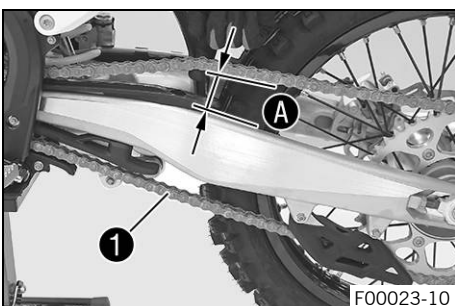

**Preparatory work**

- Raise the motorcycle with a lift stand. (🔧 p. 42)

**Main work**

- Pull the chain at the end of the chain sliding piece upward to measure chain tension **A**.

Guideline

The lower chain section **1** must be taut.

**Info**  
 Chain wear is not always even, so you should repeat this measurement at different chain positions.

|               |                               |
|---------------|-------------------------------|
| Chain tension | 55... 58 mm (2.17... 2.28 in) |
|---------------|-------------------------------|

- » If the chain tension does not meet the specification:
  - Adjust the chain tension. (📖 p. 61)

**Finishing work**

- Remove the motorcycle from the lift stand. (📖 p. 42)

**11.37 Adjusting the chain tension**

**Warning**  
**Danger of accidents** Incorrect chain tension damages components and results in accidents.

If the chain is tensioned too much, the chain, engine sprocket, rear sprocket, transmission and rear wheel bearings wear more quickly. Some components may break if overloaded.  
 If the chain is too loose, the chain may fall off the engine sprocket or the rear sprocket. As a result, the rear wheel locks or the engine will be damaged.

- Check the chain tension regularly.
- Set the chain tension in accordance with the specification.

**Preparatory work**

- Raise the motorcycle with a lift stand. (📖 p. 42)
- Check the chain tension. (📖 p. 60)

**Main work**

- Loosen nut ❶.
- Loosen nuts ❷.
- Adjust the chain tension by turning adjusting screws ❸ to the left and right.

**Guideline**

|   |                               |
|---|-------------------------------|
| Chain tension   | 55... 58 mm (2.17... 2.28 in) |
| Turn adjusting screws ❸ on the left and right so that the markings on the left and right chain adjusters are in the same position relative to reference marks A. The rear wheel is now correctly aligned. |                               |

- Tighten nuts ❷.
- Make sure that chain adjusters ❹ are fitted correctly on adjusting screws ❸.
- Tighten nut ❶.

**Guideline**

|                         |         |                   |
|-------------------------|---------|-------------------|
| Nut, rear wheel spindle | M25x1.5 | 80 Nm (59 lbf ft) |
|-------------------------|---------|-------------------|

**i Info**  
 The wide adjustment range of the chain adjusters (32 mm) enables different secondary ratios with the same chain length.  
 Chain adjusters ❹ can be turned by 180°.

**Finishing work**

- Remove the motorcycle from the lift stand. (📖 p. 42)

**11.38 Checking the chain, rear sprocket, engine sprocket and chain guide**

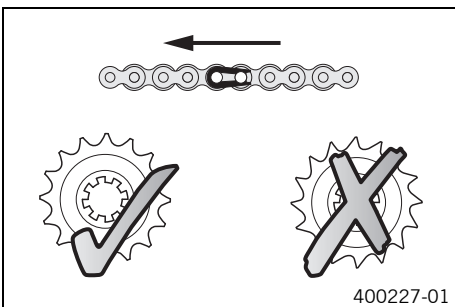

**Preparatory work**

- Raise the motorcycle with a lift stand. (📖 p. 42)

**Main work**

- Shift the transmission to idle.
- Check the rear sprocket and engine sprocket for wear.
  - » If the rear sprocket and engine sprocket are worn:
    - Change the drivetrain kit. 🛠️

**i Info**  
 The engine sprocket, rear sprocket and chain should always be replaced together.

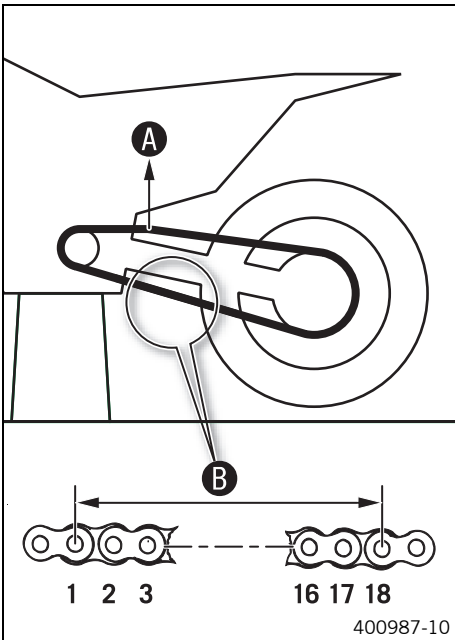

- Pull at the top part of the chain with the specified weight **A**.

Guideline

|                                |                            |
|--------------------------------|----------------------------|
| Weight, chain wear measurement | 10... 15 kg (22... 33 lb.) |
|--------------------------------|----------------------------|

- Measure distance **B** of 18 chain rollers in the lower chain section.

**i Info**

Chain wear is not always even, so you should repeat this measurement at different chain positions.

|  |                   |
|--|-------------------|
| Maximum distance <b>B</b> at the longest chain section | 272 mm (10.71 in) |
|--|-------------------|

- » If distance **B** is greater than the specified measurement:
  - Change the drivetrain kit. 🛠️

**i Info**

When a new chain is mounted, the rear sprocket and engine sprocket should also be changed.  
New chains wear out faster on old, worn sprockets.

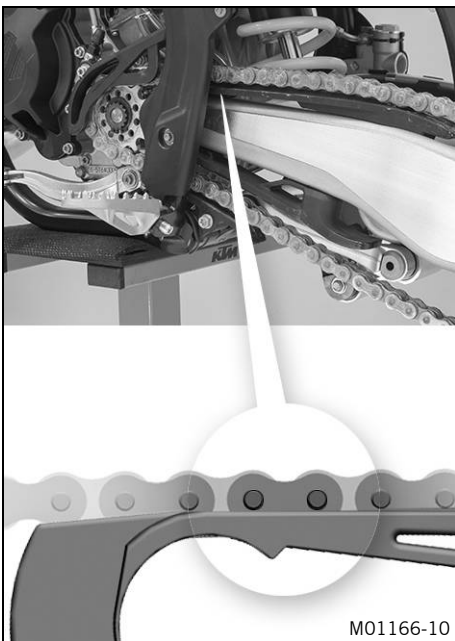

- Check the chain sliding guard for wear.
  - » If the lower edge of the chain pins is in line with, or below, the chain sliding guard:
    - Change the chain sliding guard. 🛠️
- Check that the chain sliding guard is firmly seated.
  - » If the chain sliding guard is loose:
    - Tighten the screws on the chain sliding guard.

Guideline

|                            |    |                   |               |
|----------------------------|----|-------------------|---------------|
| Screw, chain sliding guard | M6 | 6 Nm (4.4 lbf ft) | Loctite® 243™ |
|----------------------------|----|-------------------|---------------|



- Check the chain sliding piece for wear.
  - » If the lower edge of the chain pins is in line with or below the chain sliding piece:
    - Change the chain sliding piece. 🛠️
- Check that the chain sliding piece is firmly seated.
  - » If the chain sliding piece is loose:
    - Tighten the screw on the chain sliding piece.

Guideline

|                            |    |                     |
|----------------------------|----|---------------------|
| Screw, chain sliding piece | M8 | 15 Nm (11.1 lbf ft) |
|----------------------------|----|---------------------|



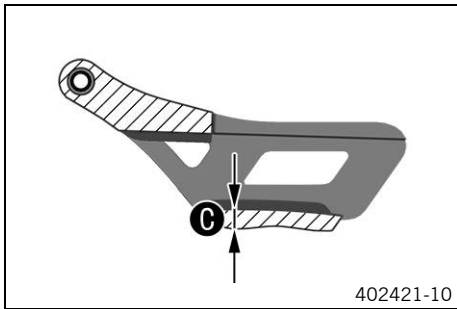

- Check the chain guide with a slide gauge for dimension **C**.

|   |                |
|---|----------------|
| Minimum thickness <b>C</b> of the chain guide | 6 mm (0.24 in) |
|---|----------------|

- » If the measured value is less than the specification:
  - Change the chain guide. 🛠️

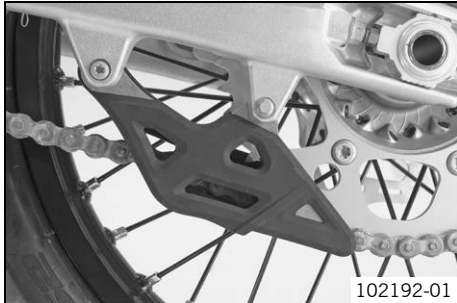

- Check that the chain guide is firmly seated.
  - » If the chain guide is loose:
    - Tighten the screws on the chain guide.

Guideline

|                           |    |                       |
|---------------------------|----|-----------------------|
| Remaining screws, chassis | M6 | 10 Nm<br>(7.4 lbf ft) |
| Remaining nuts, chassis   | M6 | 10 Nm<br>(7.4 lbf ft) |

**Finishing work**

- Remove the motorcycle from the lift stand. (📖 p. 42)

## 11.39 Checking the frame 🛠️

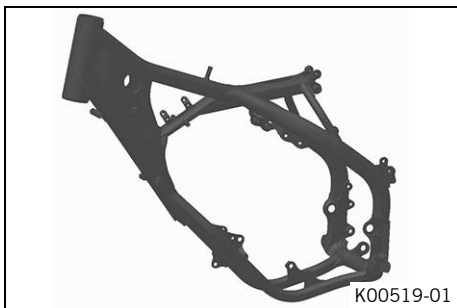

- Check the frame for cracks and deformation.
  - » If the frame exhibits cracks or deformation due to a mechanical impact:
    - Change the frame. 🛠️

**i Info**  
Always replace a frame that has been damaged due to a mechanical impact. Repair of the frame is not authorized by KTM.

## 11.40 Checking the swingarm 🛠️



- Check the swingarm for damage, cracking, and deformation.
  - » If the swingarm shows signs of damage, cracking, or deformation:
    - Change the swingarm. 🛠️

**i Info**  
Always change a damaged swingarm. Repair of the swingarm is not authorized by KTM.

## 11.41 Checking the throttle cable routing



**Warning**

**Danger of accidents** The throttle cable may slip out of the guide if routed incorrectly. The throttle slide will then no longer be closed and the speed can no longer be controlled.

- Make sure that the throttle cable routing and the play in throttle cable complies with the specification.

**Preparatory work**

- Remove the seat. (📖 p. 52)

**(All SX models)**

- Turn handle **1** of the fuel tap to the **OFF** position. (Figure A00016-10📖 p. 15)

**(All XC models)**

- Turn handle ❶ of the fuel tap to the **OFF** position. (Figure A00023-10 p. 15)
- Remove the fuel tank. (p. 57)

**Main work**

- Check the throttle cable routing.

The throttle cable must be routed along the back of the handlebar, to the right of the frame, above the fuel tank bracket, and to the carburetor. The throttle cable must be fixed on the fuel tank bracket with a rubber band.

- » If the throttle cable is not routed as specified:
  - Correct the throttle cable routing.

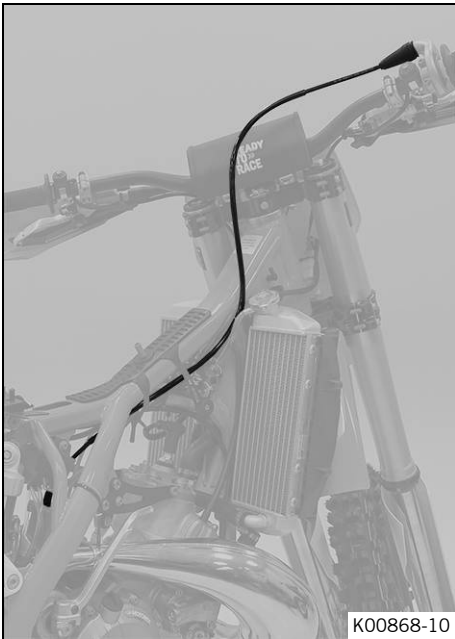

**Finishing work**

- Install the fuel tank. (p. 58)
- Mount the seat. (p. 53)

## 11.42 Checking the rubber grip

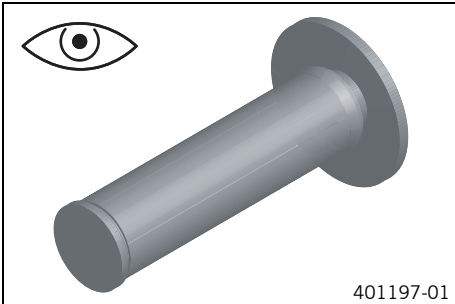

- Check the rubber grips on the handlebar for damage, wear, and looseness.

**i Info**  
 The rubber grips are vulcanized onto a sleeve on the left and onto the handle tube of the throttle grip on the right. The left sleeve is clamped onto the handlebar.  
 The rubber grip can only be replaced with the sleeve or the throttle tube.

- » If a rubber grip is damaged or worn:
  - Change the rubber grip.

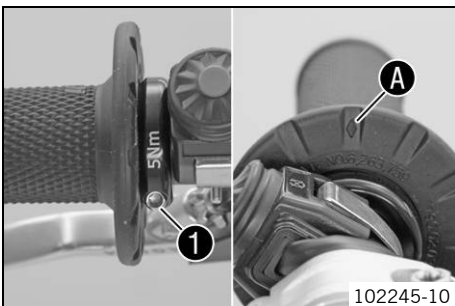

- Check that screw ❶ is firmly seated.

**Guideline**

|                   |    |                      |               |
|-------------------|----|----------------------|---------------|
| Screw, fixed grip | M4 | 5 Nm<br>(3.7 lbf ft) | Loctite® 243™ |
|-------------------|----|----------------------|---------------|

Diamond ❸ must be located at the top.

## 11.43 Adjusting basic position of clutch lever

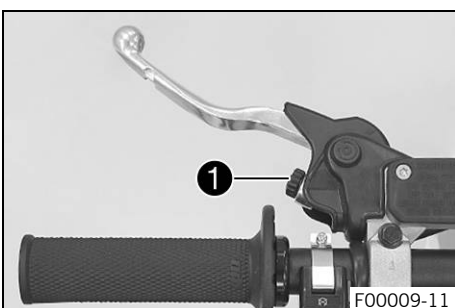

- Adjust the basic setting of the clutch lever to your hand size by turning adjusting screw ❶.

**i Info**  
 Turn the adjusting screw counterclockwise to decrease the distance between the clutch lever and the handlebar.  
 Turn the adjusting screw clockwise to increase the distance between the clutch lever and the handlebar.  
 The range of adjustment is limited.  
 Turn the adjusting screw by hand only, and do not apply any force.  
 Do not make any adjustments while riding.

## 11.44 Checking/correcting the fluid level of the hydraulic clutch

**Warning**  
**Skin irritation** Brake fluid causes skin irritation.

- Keep brake fluid out of the reach of children.
- Wear suitable protective clothing and safety glasses.
- Do not allow brake fluid to come into contact with the skin, the eyes or clothing.
- Consult a doctor immediately if brake fluid has been swallowed.
- Rinse the affected area with plenty of water in the event of contact with the skin.
- Rinse eyes thoroughly with water immediately and consult a doctor if brake fluid comes into contact with the eyes.
- If brake fluid spills on to your clothing, change the clothing.

**Info**  
 The fluid level rises with increasing wear of the clutch facing discs.  
 Never use DOT 5 brake fluid. It is silicone-based and purple in color. Oil seals and clutch lines are not designed for DOT 5 brake fluid.  
 Avoid contact between brake fluid and painted parts. Brake fluid attacks paint.  
 Only use clean brake fluid from a sealed container.

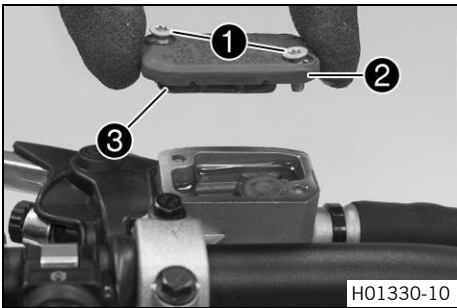

- Move the clutch fluid reservoir mounted on the handlebar to a horizontal position.
- Remove screws ①.
- Remove cover ② with membrane ③.
- Check the fluid level.

|                                 |                |
|---------------------------------|----------------|
| Fluid level below container rim | 4 mm (0.16 in) |
|---------------------------------|----------------|

- » If the fluid level does not meet specifications:
  - Correct the fluid level of the hydraulic clutch.

|  |
|--|
| Brake fluid DOT 4 / DOT 5.1 (📖 p. 119) |
|--|

- Position the cover with the membrane. Mount and tighten the screws.

**Info**  
 Clean up overflowed or spilled brake fluid immediately with water.

## 11.45 Changing the hydraulic clutch fluid 🗑️

**Warning**  
**Skin irritation** Brake fluid causes skin irritation.

- Keep brake fluid out of the reach of children.
- Wear suitable protective clothing and safety glasses.
- Do not allow brake fluid to come into contact with the skin, the eyes or clothing.
- Consult a doctor immediately if brake fluid has been swallowed.
- Rinse the affected area with plenty of water in the event of contact with the skin.
- Rinse eyes thoroughly with water immediately and consult a doctor if brake fluid comes into contact with the eyes.
- If brake fluid spills on to your clothing, change the clothing.

**Warning**  
**Environmental hazard** Hazardous substances cause environmental damage.

- Dispose of oils, grease, filters, fuel, cleaning agents, brake fluid, etc., correctly and in compliance with the applicable regulations.

**Info**  
 Never use DOT 5 brake fluid. It is silicone-based and purple in color. Oil seals and clutch lines are not designed for DOT 5 brake fluid.  
 Avoid contact between brake fluid and painted parts. Brake fluid attacks paint.  
 Only use clean brake fluid from a sealed container.

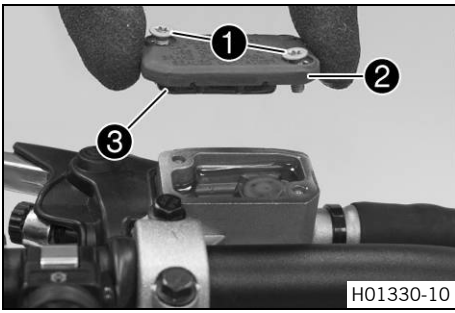

H01330-10

- Move the clutch fluid reservoir mounted on the handlebar to a horizontal position.
- Remove screws ①.
- Remove cover ② with membrane ③.

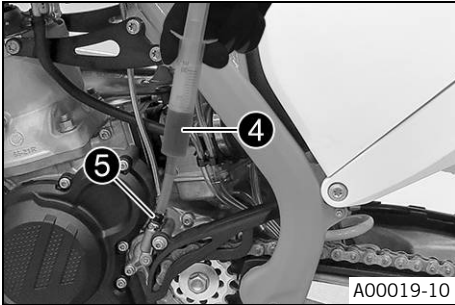

A00019-10

- Fill bleeding syringe ④ with the appropriate hydraulic fluid.

|                             |
|-----------------------------|
| Bleed syringe (50329050000) |
|-----------------------------|

|  |
|--|
| Brake fluid DOT 4 / DOT 5.1 (📖 p. 119) |
|--|

- On the clutch slave cylinder, remove bleeder screw ⑤ and mount bleeding syringe ④.

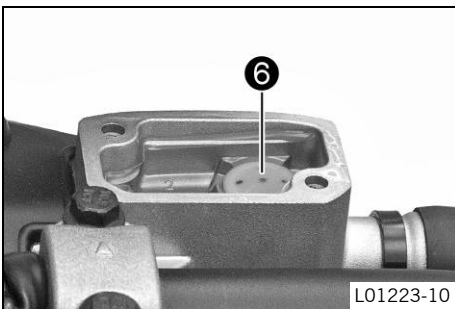

L01223-10

- Now inject the liquid into the system until it emerges from the drill hole ⑥ of the master cylinder without bubbles.
- Now and then, extract fluid from the master cylinder reservoir to prevent overflow.
- Remove the bleeding syringe. Mount and tighten screws bleeder screw.
- Correct the fluid level of the hydraulic clutch.

Guideline

|                                 |                |
|---------------------------------|----------------|
| Fluid level below container rim | 4 mm (0.16 in) |
|---------------------------------|----------------|

- Position the cover with the membrane. Mount and tighten the screws.



**Info**

Clean up overflowed or spilled brake fluid immediately with water.

## 12.1 Checking the free travel of the hand brake lever

**Warning**  
**Danger of accidents** The brake system fails in the event of overheating.

If there is no free travel on the hand brake lever, pressure builds up on the front brake circuit.

- Set the free travel on the hand brake lever in accordance with the specification.

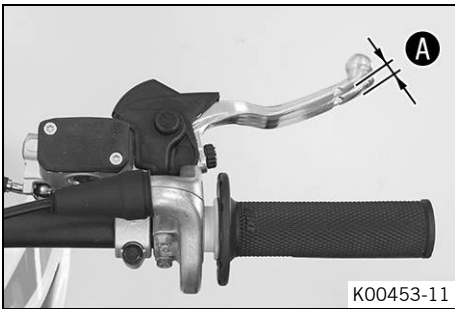

- Push the hand brake lever forward and check free travel **A**.

|                                 |                    |
|---------------------------------|--------------------|
| Free travel of hand brake lever | ≥ 3 mm (≥ 0.12 in) |
|---------------------------------|--------------------|

- » If the free travel does not meet specifications:
  - Adjust the basic position of the hand brake lever. (📖 p. 67)

## 12.2 Adjusting the basic position of the hand brake lever

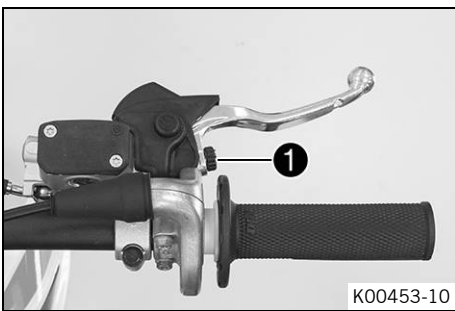

- Check the free travel of the hand brake lever. (📖 p. 67)
- Adjust the basic position of the hand brake lever to your hand size by turning adjusting screw **1**.

**i Info**  
 Turn the adjusting screw clockwise to increase the distance between the hand brake lever and the handlebar.  
 Turn the adjusting screw counterclockwise to decrease the distance between the hand brake lever and the handlebar.  
 The range of adjustment is limited.  
 Only turn the adjusting screw by hand, and do not use force.  
 Do not make any adjustments while riding.

## 12.3 Checking the brake discs

**Warning**  
**Danger of accidents** Worn-out brake discs reduce the braking effect.

- Make sure that worn-out brake discs are replaced immediately. (Your authorized KTM workshop will be glad to help.)

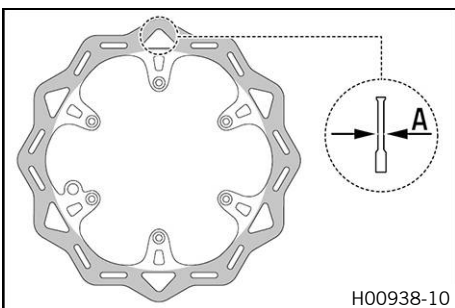

- Check the thickness of the front and rear brake discs at multiple points on each brake disc to ensure it is at least thickness **A**.

**i Info**  
 Wear reduces the thickness of the brake disc around the area used by the brake linings.

| Brake discs - wear limit |                   |
|--------------------------|-------------------|
| Front                    | 2.5 mm (0.098 in) |
| Rear                     | 3.5 mm (0.138 in) |

- » If the brake disc thickness is less than the specified value:
  - Change the front brake disc. 🛠️
  - Change the rear brake disc. 🛠️
- Check the front and rear brake discs for damage, cracking, and deformation.
  - » If the brake disc exhibits damage, cracking, or deformation:
    - Change the front brake disc. 🛠️
    - Change the rear brake disc. 🛠️

## 12.4 Checking the front brake fluid level

- Warning**  
**Danger of accidents** An insufficient brake fluid level will cause the brake system to fail.  
 If the brake fluid level drops below the specified marking or the specified value, the brake system is leaking or the brake linings are worn down.
- Check the brake system and do not continue riding until the problem is eliminated. (Your authorized KTM workshop will be glad to help.)

- Warning**  
**Danger of accidents** Old brake fluid reduces the braking effect.
- Make sure that brake fluid for the front and rear brake is changed in accordance with the service schedule. (Your authorized KTM workshop will be glad to help.)

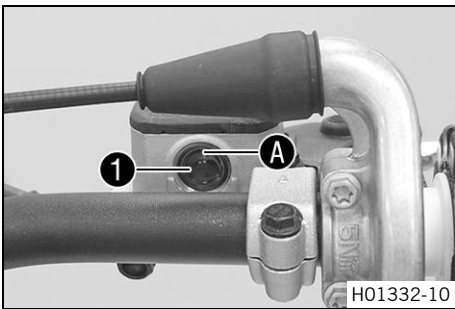
**Preparatory work**

- Check the front brake linings. (📖 p. 69)

**Main work**

- Move the brake fluid reservoir mounted on the handlebar to a horizontal position.
- Check the brake fluid level in the viewer ①.
  - » If the brake fluid level is below the A marking:
    - Add front brake fluid. 🛠️ (📖 p. 68)

## 12.5 Adding front brake fluid 🛠️

- Warning**  
**Danger of accidents** An insufficient brake fluid level will cause the brake system to fail.  
 If the brake fluid level drops below the specified marking or the specified value, the brake system is leaking or the brake linings are worn down.
- Check the brake system and do not continue riding until the problem is eliminated. (Your authorized KTM workshop will be glad to help.)

- Warning**  
**Skin irritation** Brake fluid causes skin irritation.
- Keep brake fluid out of the reach of children.
  - Wear suitable protective clothing and safety glasses.
  - Do not allow brake fluid to come into contact with the skin, the eyes or clothing.
  - Consult a doctor immediately if brake fluid has been swallowed.
  - Rinse the affected area with plenty of water in the event of contact with the skin.
  - Rinse eyes thoroughly with water immediately and consult a doctor if brake fluid comes into contact with the eyes.
  - If brake fluid spills on to your clothing, change the clothing.

- Warning**  
**Danger of accidents** Old brake fluid reduces the braking effect.
- Make sure that brake fluid for the front and rear brake is changed in accordance with the service schedule. (Your authorized KTM workshop will be glad to help.)

- Warning**  
**Environmental hazard** Hazardous substances cause environmental damage.
- Dispose of oils, grease, filters, fuel, cleaning agents, brake fluid, etc., correctly and in compliance with the applicable regulations.

**i Info**

Never use DOT 5 brake fluid. It is silicone-based and purple in color. Oil seals and brake lines are not designed for DOT 5 brake fluid.  
 Avoid contact between brake fluid and painted parts. Brake fluid attacks paint.  
 Only use clean brake fluid from a sealed container.

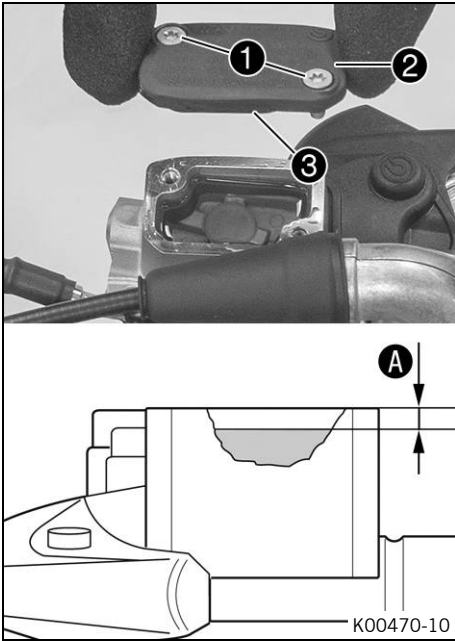

**Preparatory work**

- Check the front brake linings. (📖 p. 69)

**Main work**

- Move the brake fluid reservoir mounted on the handlebar to a horizontal position.
- Remove screws ①.
- Remove cover ② with membrane ③.
- Add brake fluid to level A.

**Guideline**

|   |               |
|---|---------------|
| Level A (brake fluid level below reservoir rim) | 5 mm (0.2 in) |
|---|---------------|

|  |
|--|
| Brake fluid DOT 4 / DOT 5.1 (📖 p. 119) |
|--|

- Position the cover with the membrane. Mount and tighten the screws.

**i Info**

Clean up overflowed or spilled brake fluid immediately with water.

## 12.6 Checking the front brake linings

**Warning**

**Danger of accidents** Worn-out brake linings reduce the braking effect.

- Ensure that worn-out brake linings are replaced immediately. (Your authorized KTM workshop will be glad to help.)

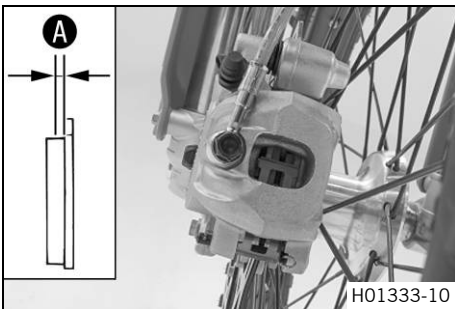

- Check the brake linings for minimum thickness A.

|                     |                    |
|---------------------|--------------------|
| Minimum thickness A | ≥ 1 mm (≥ 0.04 in) |
|---------------------|--------------------|

- » If the minimum thickness is less than specified:
  - Change the front brake linings. 🛠️ (📖 p. 69)
- Check the brake linings for damage and cracking.
  - » If damage or cracking is visible:
    - Change the front brake linings. 🛠️ (📖 p. 69)

## 12.7 Changing the front brake linings 🛠️

**Warning**

**Danger of accidents** Incorrect maintenance will cause the brake system to fail.

- Ensure that service work and repairs are performed professionally. (Your authorized KTM workshop will be glad to help.)



**Warning**

**Skin irritation** Brake fluid causes skin irritation.

- Keep brake fluid out of the reach of children.
- Wear suitable protective clothing and safety glasses.
- Do not allow brake fluid to come into contact with the skin, the eyes or clothing.
- Consult a doctor immediately if brake fluid has been swallowed.
- Rinse the affected area with plenty of water in the event of contact with the skin.
- Rinse eyes thoroughly with water immediately and consult a doctor if brake fluid comes into contact with the eyes.
- If brake fluid spills on to your clothing, change the clothing.



**Warning**

**Danger of accidents** Old brake fluid reduces the braking effect.

- Make sure that brake fluid for the front and rear brake is changed in accordance with the service schedule. (Your authorized KTM workshop will be glad to help.)



**Warning**

**Danger of accidents** Oil or grease on the brake discs reduces the braking effect.

- Always keep the brake discs free of oil and grease.
- Clean the brake discs with brake cleaner when necessary.



**Warning**

**Danger of accidents** Brake linings which have not been approved alter the braking efficiency.

Not all brake linings are tested and approved for KTM motorcycles. The structure and friction coefficient of the brake linings, and thus their brake power, may vary greatly from that of original brake linings.

If brake linings are used that differ from the original equipment, compliance with the original homologation is not guaranteed. In this case, the vehicle no longer corresponds to its condition at delivery and the warranty shall be void.

- Only use brake linings approved and recommended by KTM.



**Warning**

**Environmental hazard** Hazardous substances cause environmental damage.

- Dispose of oils, grease, filters, fuel, cleaning agents, brake fluid, etc., correctly and in compliance with the applicable regulations.



**Info**

Never use DOT 5 brake fluid. It is silicone-based and purple in color. Oil seals and brake lines are not designed for DOT 5 brake fluid.

Avoid contact between brake fluid and painted parts. Brake fluid attacks paint.

Only use clean brake fluid from a sealed container.

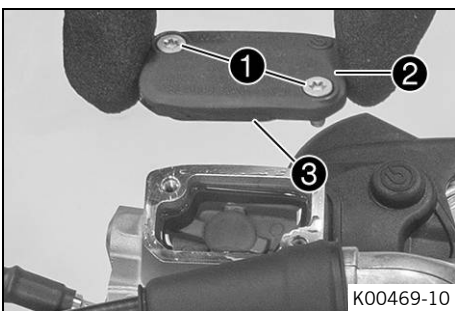

- Move the brake fluid reservoir mounted on the handlebar to a horizontal position.
- Remove screws **1**.
- Remove cover **2** with membrane **3**.
- Manually press the brake caliper toward the brake disc to push back the brake pistons. Ensure that brake fluid does not flow out of the brake fluid reservoir, if necessary extract excess.



**Info**

Make sure that you do not press the brake caliper against the spokes when pushing back the brake pistons.

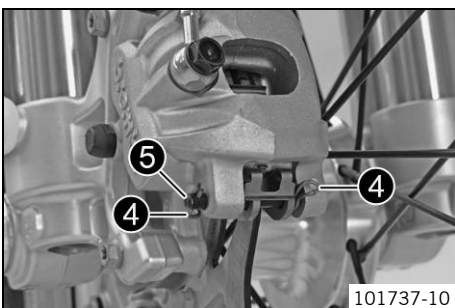

- Remove cotter pins **4**, pull out pin **5**, and remove the brake linings.
- Clean the brake caliper and brake caliper support.



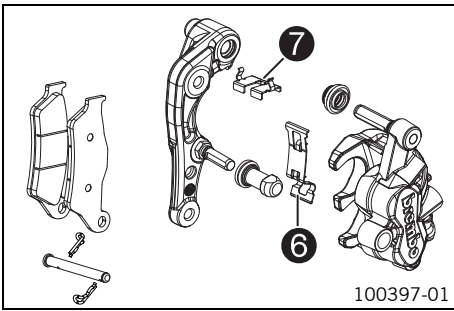

- Check that leaf spring **6** in the brake caliper and sliding plate **7** in the brake caliper support are seated correctly.

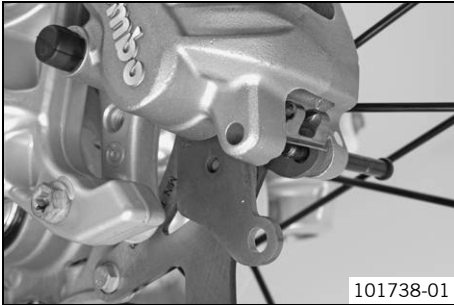

- Insert the new brake linings, insert the pin, and mount the cotter pins.



**Info**

Always change the brake linings in pairs.

- Operate the hand brake lever repeatedly until the brake linings are in contact with the brake disc and there is a pressure point.

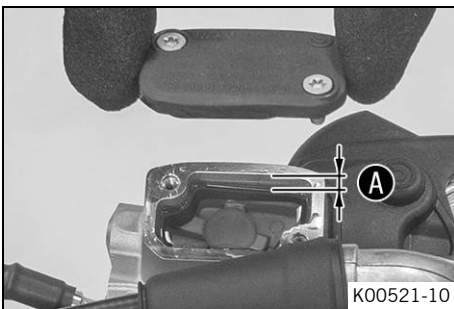

- Correct the brake fluid quantity to level **A**.

Guideline

|  |               |
|--|---------------|
| Level <b>A</b> (brake fluid level below reservoir rim) | 5 mm (0.2 in) |
|--|---------------|

Brake fluid DOT 4 / DOT 5.1 (📖 p. 119)

- Position the cover with the membrane. Mount and tighten the screws.



**Info**

Clean up overflowed or spilled brake fluid immediately with water.

## 12.8 Checking the free travel of foot brake lever



**Warning**

**Danger of accidents** The brake system fails in the event of overheating.

If there is no free travel on the foot brake lever, pressure builds up in the brake system on the rear brake.

- Set the free travel on the foot brake lever in accordance with the specification.

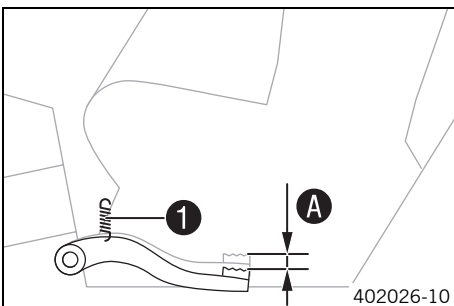

- Disconnect spring **1**.
- Move the foot brake lever back and forth between the end stop and the contact to the foot brake cylinder piston and check free travel **A**.

Guideline

|                                 |                            |
|---------------------------------|----------------------------|
| Free travel at foot brake lever | 3... 5 mm (0.12... 0.2 in) |
|---------------------------------|----------------------------|

- » If the free travel does not meet specifications:
  - Adjust the basic position of the foot brake lever. 🛠️ (📖 p. 71)
- Reconnect spring **1**.

## 12.9 Adjusting the basic position of the foot brake lever 🛠️



**Warning**

**Danger of accidents** The brake system fails in the event of overheating.

If there is no free travel on the foot brake lever, pressure builds up in the brake system on the rear brake.

- Set the free travel on the foot brake lever in accordance with the specification.

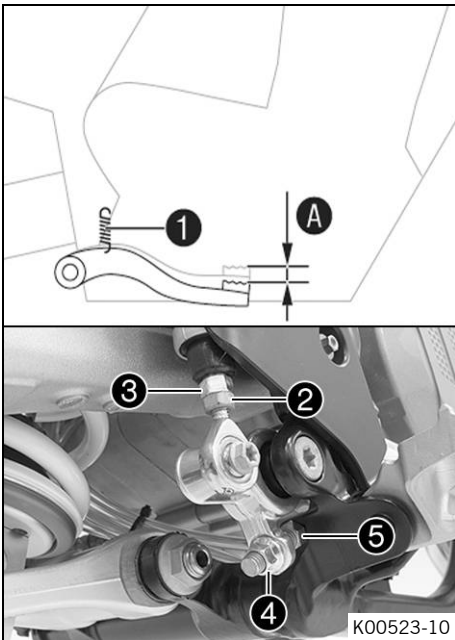

- Detach spring ①.
- Loosen nut ② and, with push rod ③, turn it back until you have maximum free travel.
- To adjust the basic position of the foot brake lever to individual requirements, loosen nut ④ and turn screw ⑤ accordingly.



**Info**

The range of adjustment is limited.

- Turn push rod ③ accordingly until you have free travel A. If necessary, adjust the basic position of the foot brake lever.

**Guideline**

|                                 |                            |
|---------------------------------|----------------------------|
| Free travel at foot brake lever | 3... 5 mm (0.12... 0.2 in) |
|---------------------------------|----------------------------|

- Hold screw ⑤ and tighten nut ④.

**Guideline**

|                            |    |                        |
|----------------------------|----|------------------------|
| Nut, foot brake lever stop | M8 | 20 Nm<br>(14.8 lbf ft) |
|----------------------------|----|------------------------|

- Hold push rod ③ and tighten nut ②.

**Guideline**

|                         |    |                    |
|-------------------------|----|--------------------|
| Remaining nuts, chassis | M6 | 10 Nm (7.4 lbf ft) |
|-------------------------|----|--------------------|

- Attach spring ①.

## 12.10 Checking the rear brake fluid level



**Warning**

**Danger of accidents** An insufficient brake fluid level will cause the brake system to fail.

If the brake fluid level drops below the specified marking or the specified value, the brake system is leaking or the brake linings are worn down.

- Check the brake system and do not continue riding until the problem is eliminated. (Your authorized KTM workshop will be glad to help.)



**Warning**

**Danger of accidents** Old brake fluid reduces the braking effect.

- Make sure that brake fluid for the front and rear brake is changed in accordance with the service schedule. (Your authorized KTM workshop will be glad to help.)

**Preparatory work**

- Check the rear brake linings. (📖 p. 73)

**Main work**

- Stand the vehicle upright.
- Check the brake fluid level in level viewer ①.
  - » If the brake fluid has dropped below marking A:
    - Add rear brake fluid. 🛠️ (📖 p. 73)

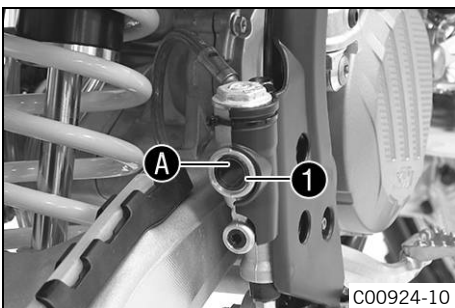

12.11 Adding rear brake fluid **Warning****Danger of accidents** An insufficient brake fluid level will cause the brake system to fail.

If the brake fluid level drops below the specified marking or the specified value, the brake system is leaking or the brake linings are worn down.

- Check the brake system and do not continue riding until the problem is eliminated. (Your authorized KTM workshop will be glad to help.)

**Warning****Skin irritation** Brake fluid causes skin irritation.

- Keep brake fluid out of the reach of children.
- Wear suitable protective clothing and safety glasses.
- Do not allow brake fluid to come into contact with the skin, the eyes or clothing.
- Consult a doctor immediately if brake fluid has been swallowed.
- Rinse the affected area with plenty of water in the event of contact with the skin.
- Rinse eyes thoroughly with water immediately and consult a doctor if brake fluid comes into contact with the eyes.
- If brake fluid spills on to your clothing, change the clothing.

**Warning****Danger of accidents** Old brake fluid reduces the braking effect.

- Make sure that brake fluid for the front and rear brake is changed in accordance with the service schedule. (Your authorized KTM workshop will be glad to help.)

**Warning****Environmental hazard** Hazardous substances cause environmental damage.

- Dispose of oils, grease, filters, fuel, cleaning agents, brake fluid, etc., correctly and in compliance with the applicable regulations.

**Info**

Never use DOT 5 brake fluid. It is silicone-based and purple in color. Oil seals and brake lines are not designed for DOT 5 brake fluid.

Avoid contact between brake fluid and painted parts. Brake fluid attacks paint.

Only use clean brake fluid from a sealed container.

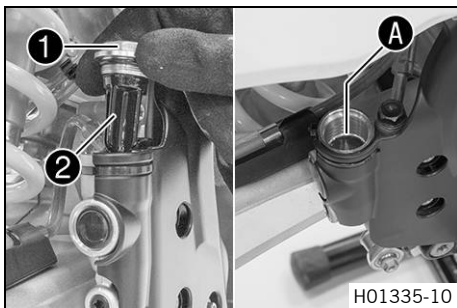
**Preparatory work**

- Check the rear brake linings. ( p. 73)

**Main work**

- Stand the vehicle upright.
- Remove screw cap ① with membrane ② and the O-ring.
- Add brake fluid to level A.

Brake fluid DOT 4 / DOT 5.1 ( p. 119)

- Mount the screw cap with the membrane and the O-ring.

**Info**

Clean up overflowed or spilled brake fluid immediately with water.

## 12.12 Checking the rear brake linings

**Warning****Danger of accidents** Worn-out brake linings reduce the braking effect.

- Ensure that worn-out brake linings are replaced immediately. (Your authorized KTM workshop will be glad to help.)

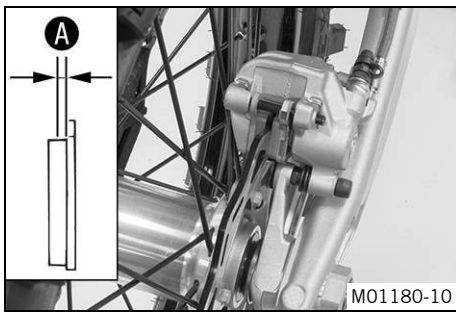

- Check the brake linings for minimum thickness **A**.

|                            |   |
|----------------------------|---|
| Minimum thickness <b>A</b> | $\geq 1 \text{ mm } (\geq 0.04 \text{ in})$ |
|----------------------------|---|

- » If the minimum thickness is less than specified:
  - Change the rear brake linings. 🛠️ (📖 p. 74)
- Check the brake linings for damage and cracking.
  - » If damage or cracking is visible:
    - Change the rear brake linings. 🛠️ (📖 p. 74)

## 12.13 Changing the rear brake linings 🛠️

- Warning**  
**Danger of accidents** Incorrect maintenance will cause the brake system to fail.
- Ensure that service work and repairs are performed professionally. (Your authorized KTM workshop will be glad to help.)

- Warning**  
**Skin irritation** Brake fluid causes skin irritation.
- Keep brake fluid out of the reach of children.
  - Wear suitable protective clothing and safety glasses.
  - Do not allow brake fluid to come into contact with the skin, the eyes or clothing.
  - Consult a doctor immediately if brake fluid has been swallowed.
  - Rinse the affected area with plenty of water in the event of contact with the skin.
  - Rinse eyes thoroughly with water immediately and consult a doctor if brake fluid comes into contact with the eyes.
  - If brake fluid spills on to your clothing, change the clothing.

- Warning**  
**Danger of accidents** Old brake fluid reduces the braking effect.
- Make sure that brake fluid for the front and rear brake is changed in accordance with the service schedule. (Your authorized KTM workshop will be glad to help.)

- Warning**  
**Environmental hazard** Hazardous substances cause environmental damage.
- Dispose of oils, grease, filters, fuel, cleaning agents, brake fluid, etc., correctly and in compliance with the applicable regulations.

- i Info**
- Never use DOT 5 brake fluid. It is silicone-based and purple in color. Oil seals and brake lines are not designed for DOT 5 brake fluid.  
 Avoid contact between brake fluid and painted parts. Brake fluid attacks paint.  
 Only use clean brake fluid from a sealed container.

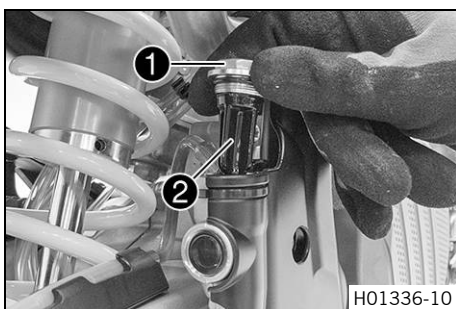

- Stand the vehicle upright.
- Remove screw cap **1** with membrane **2** and the O-ring.

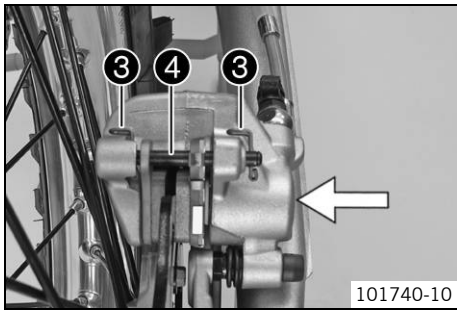

101740-10

- Manually press the brake caliper to the brake disc to push back the brake piston. Ensure that brake fluid does not flow out of the brake fluid reservoir, extracting it by suction if it does.

**i Info**

Make sure when pushing back the brake piston that you do not press the brake caliper against the spokes.

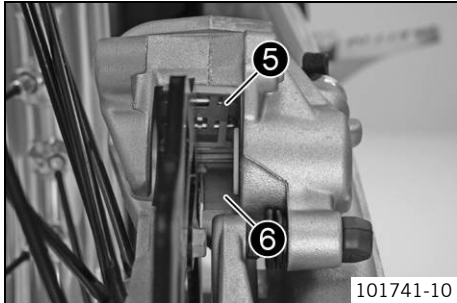

101741-10

- Remove cotter pins ③, pull out pin ④, and remove the brake linings.
- Clean the brake caliper and brake caliper support.
- Check that leaf spring ⑤ in the brake caliper and sliding plate ⑥ in the brake caliper support are seated correctly.

**i Info**

The arrow on the leaf spring points in the rotation direction of the brake disc.

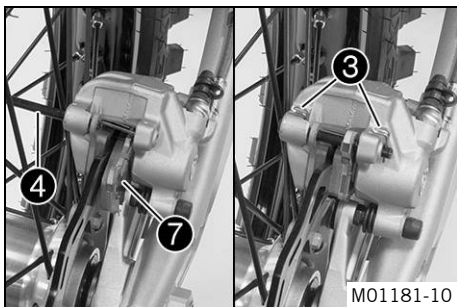

M01181-10

- Insert the new brake linings, insert pin ④, and mount cotter pins ③.

**i Info**

Always change the brake linings in pairs.  
Make sure that decoupling plate ⑦ is mounted on the piston side brake lining.

- Operate the foot brake lever repeatedly until the brake linings are in contact with the brake disc and there is a pressure point.

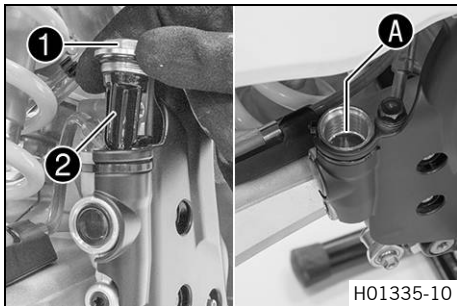

H01335-10

- Add brake fluid to level A.

Brake fluid DOT 4 / DOT 5.1 (🗨 p. 119)

- Mount and tighten screw cap ① with membrane ② and the O-ring.

**i Info**

Clean up overflowed or spilled brake fluid immediately with water.

## 13.1 Removing the front wheel

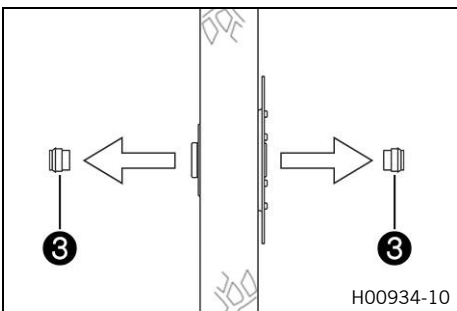
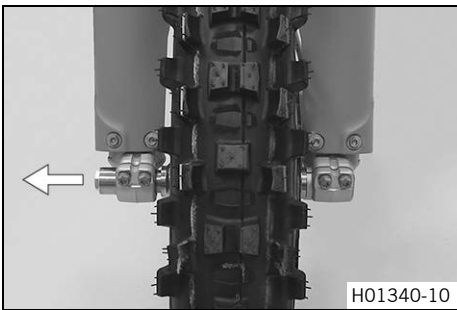
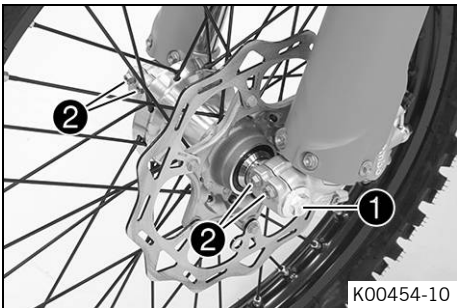
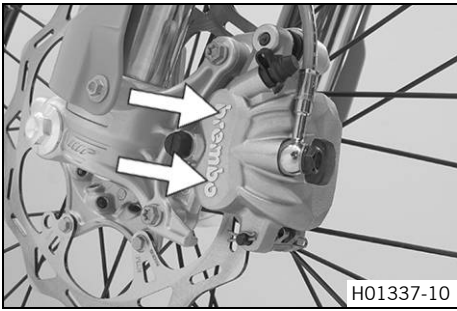

### Preparatory work

- Raise the motorcycle with a lift stand. (📖 p. 42)

### Main work

- Press the brake caliper onto the brake disc by hand in order to push back the brake pistons.

#### **i** Info

Make sure that you do not press the brake caliper against the spokes when pushing back the brake pistons.

- Loosen screw ① by several rotations.
- Loosen screws ②.
- Press on screw ① to push the wheel spindle out of the axle clamp.
- Remove screw ①.

#### **!** Warning

**Danger of accidents** Damaged brake discs reduce the braking effect.

- Always lay the wheel down in such a way that the brake disc is not damaged.

- Holding the front wheel, withdraw the wheel spindle. Take the front wheel out of the fork.

#### **i** Info

Do not pull the hand brake lever when the front wheel is removed.

- Remove spacers ③.

## 13.2 Installing the front wheel

### **!** Warning

**Danger of accidents** Oil or grease on the brake discs reduces the braking effect.

- Always keep the brake discs free of oil and grease.
- Clean the brake discs with brake cleaner when necessary.

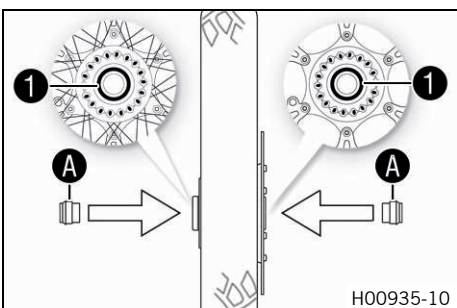

- Check the wheel bearing for damage and wear.
  - » If the wheel bearing is damaged or worn:
    - Change the front wheel bearing. 🛠️
- Clean and grease shaft seal rings ① and contact surface A of the spacers.

Long-life grease (📖 p. 121)

- Insert the spacers.

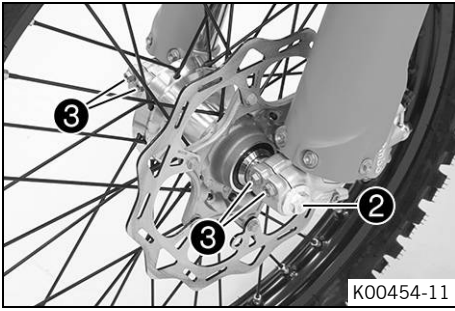

K00454-11

- Clean and grease the wheel spindle.

Long-life grease (📖 p. 121)

- Lift the front wheel into the fork, position it, and insert the wheel spindle.
  - ✓ The brake linings are correctly positioned.
- Mount and tighten screw 2.

Guideline

|                            |         |                        |
|----------------------------|---------|------------------------|
| Screw, front wheel spindle | M20x1.5 | 35 Nm<br>(25.8 lbf ft) |
|----------------------------|---------|------------------------|

- Operate the hand brake lever several times until the brake linings are seated correctly against the brake disc.
- Remove the motorcycle from the lift stand. (📖 p. 42)
- Operate the front brake and compress the fork a few times firmly.
  - ✓ The fork legs straighten.
- Tighten screws 3.

Guideline

|                  |    |                        |
|------------------|----|------------------------|
| Screw, fork stub | M8 | 15 Nm<br>(11.1 lbf ft) |
|------------------|----|------------------------|

## 13.3 Removing the rear wheel ↩

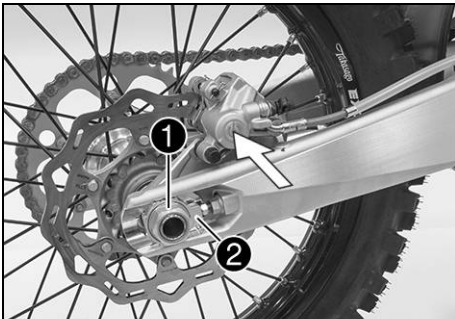

H00027-10

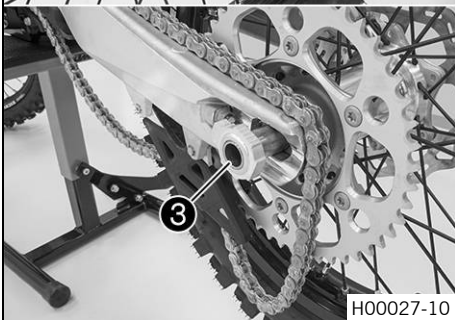

H00936-10

### Preparatory work

- Raise the motorcycle with a lift stand. (📖 p. 42)

### Main work

- Press the brake caliper onto the brake disc by hand in order to push back the brake piston.

#### Info

Make sure when pushing back the brake piston that you do not press the brake caliper against the spokes.

- Remove nut 1.
- Remove chain adjuster 2. Withdraw wheel spindle 3 only enough to allow the rear wheel to be pushed forward.
- Push the rear wheel forward as far as possible. Remove the chain from the rear sprocket.

#### Info

Cover the components to protect them against damage.

#### Warning

**Danger of accidents** Damaged brake discs reduce the braking effect.

- Always lay the wheel down in such a way that the brake disc is not damaged.

- Holding the rear wheel, withdraw the wheel spindle. Take the rear wheel out of the swingarm.

#### Info

Do not operate the foot brake lever when the rear wheel is removed.

- Remove spacers 4.

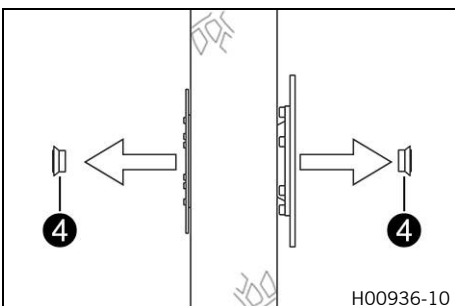

H00936-10

## 13.4 Installing the rear wheel

**Warning**  
**Danger of accidents** Oil or grease on the brake discs reduces the braking effect.

- Always keep the brake discs free of oil and grease.
- Clean the brake discs with brake cleaner when necessary.

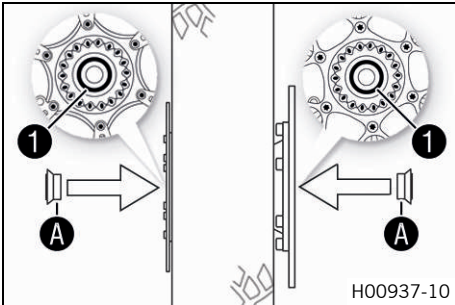

### Main work

- Check the wheel bearing for damage and wear.
  - » If the wheel bearing is damaged or worn:
    - Change the rear wheel bearing.
- Clean and grease shaft seal rings ① and contact surface A of the spacers.

Long-life grease (p. 121)

- Insert the spacers.
- Clean and grease the wheel spindle.

Long-life grease (p. 121)

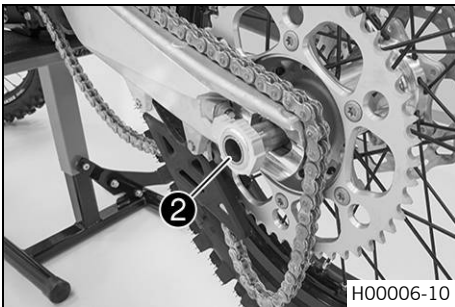

- Position the rear wheel and insert wheel spindle ②.
  - ✓ The brake linings are correctly positioned.
- Mount the chain.

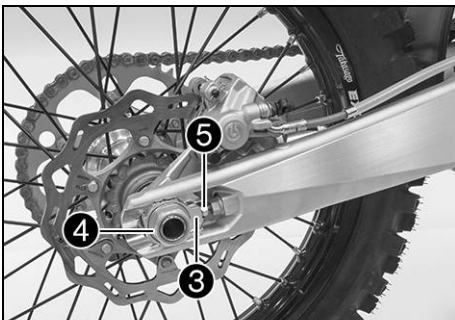

- Position chain adjuster ③. Mount nut ④, but do not tighten it yet.
- Make sure that chain adjusters ③ are fitted correctly on adjusting screws ⑤.
- Check the chain tension. (p. 60)
- Tighten nut ④.

### Guideline

|                         |         |                   |
|-------------------------|---------|-------------------|
| Nut, rear wheel spindle | M25x1.5 | 80 Nm (59 lbf ft) |
|-------------------------|---------|-------------------|

**i Info**

The wide adjustment range of the chain adjusters (32 mm (1.26 in)) enables different secondary ratios with the same chain length. Chain adjusters ③ can be turned by 180°.

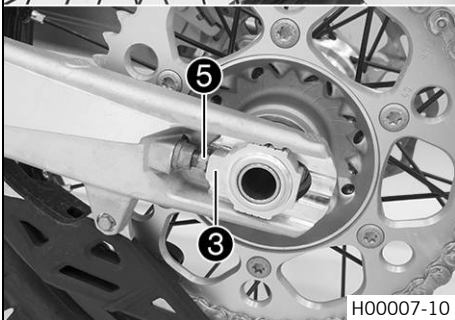

- Operate the foot brake lever repeatedly until the brake linings are in contact with the brake disc and there is a pressure point.

### Finishing work

- Remove the motorcycle from the lift stand. (p. 42)



## 13.5 Checking the tire condition

**i Info**  
 Only mount tires approved and/or recommended by KTM.  
 Other tires could have a negative effect on handling characteristics.  
 The type, condition, and air pressure of the tires all have a major impact on the handling of the motorcycle.  
 The tires mounted on the front and rear wheels must have a similar profile.  
 Worn tires have a negative effect on handling characteristics, especially on wet surfaces.

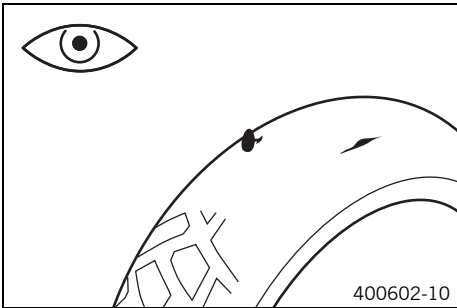

- Check the front and rear tires for cuts, run-in objects, and other damage.
  - » If the tires have cuts, run-in objects, or other damage:
    - Change the tires. 🛠️
- Check the tread depth.

**i Info**  
 Adhere to the legally required minimum tread depth.

|                     |                    |
|---------------------|--------------------|
| Minimum tread depth | ≥ 2 mm (≥ 0.08 in) |
|---------------------|--------------------|

- » If the tread depth is less than the minimum tread depth:
  - Change the tires. 🛠️
- Check the tire age.

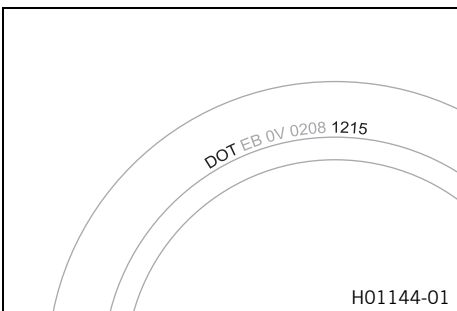

**i Info**  
 The tire date of manufacture is usually contained in the tire label and is indicated by the last four digits of the **DOT** number. The first two digits indicate the week of manufacture and the last two digits the year of manufacture.  
 KTM recommends that the tires be changed after 5 years at the latest, regardless of the actual state of wear.

- » If the tires are more than 5 years old:
  - Change the tires. 🛠️

## 13.6 Checking the tire air pressure

**i Info**  
 Low tire air pressure leads to abnormal wear and overheating of the tire.  
 Correct tire air pressure ensures optimal riding comfort and maximum tire service life.

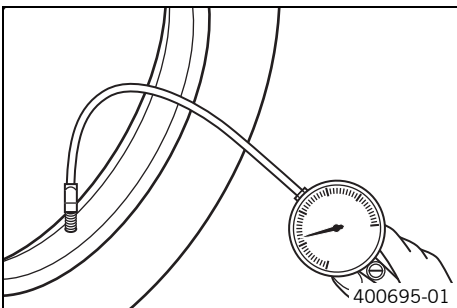

- Remove the dust cap.
- Check the tire air pressure when the tires are cold.

| Tire air pressure off road |                  |
|----------------------------|------------------|
| Front                      | 1.0 bar (15 psi) |
| Rear                       | 1.0 bar (15 psi) |

- » If the tire pressure does not meet specifications:
  - Correct the tire pressure.
- Mount the dust cap.

## 13.7 Checking spoke tension

**⚠ Warning**  
**Danger of accidents** Incorrectly tensioned spokes impair the handling characteristic and result in secondary damage.  
 The spokes break due to being overloaded if they are too tightly tensioned. If the tension in the spokes is too low, then lateral and radial run-out will form in the wheel. Other spokes will become looser as a result.

- Check spoke tension regularly, and in particular on a new vehicle. (Your authorized KTM workshop will be glad to help.)

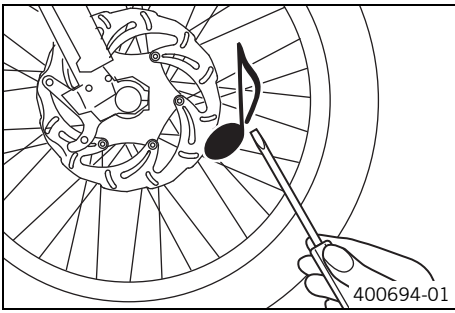

- Strike each spoke briefly using a screwdriver blade.

**i Info**

The frequency of the sound depends on the spoke length and spoke diameter.  
 If you hear different tone frequencies from different spokes of equal length and diameter, this is an indication of different spoke tensions.

You should hear a high note.

- » If the spoke tension differs:
  - Correct the spoke tension. 🛠️
- Check the spoke torque.

Guideline

|                           |      |                   |
|---------------------------|------|-------------------|
| Spoke nipple, front wheel | M4.5 | 6 Nm (4.4 lbf ft) |
| Spoke nipple, rear wheel  | M4.5 | 6 Nm (4.4 lbf ft) |

Torque wrench with various accessories in set (58429094000)

## 14.1 Removing the battery (All XC models)

**Warning**  
**Risk of injury** Batteries contain harmful substances.

- Keep batteries out of the reach of children.
- Keep sparks and open flames away from the batteries.
- Only charge batteries in well-ventilated rooms.
- Maintain a minimum clearance from inflammable materials when charging batteries.  
 Minimum clearance 1 m (3 ft)
- Do not charge deeply discharged batteries if charge is already below the minimum voltage.  
 Minimum voltage before the start of the charge 9 V
- Dispose of batteries with less than the minimum voltage correctly.

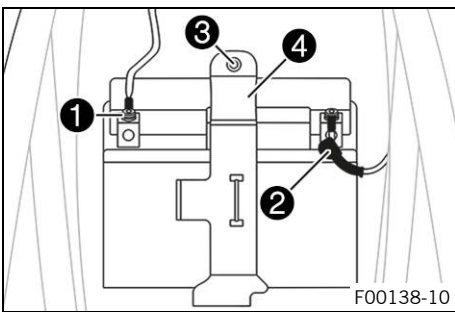

### Preparatory work

- Press and hold the kill switch  $\otimes$  while the engine is idling until the engine stops.
- Remove the seat. (📖 p. 52)

### Main work

- Disconnect negative cable ① from the battery.
- Pull back positive terminal cover ② and disconnect the positive cable from the battery.
- Remove screw ③.
- Pull holding bracket ④ forward and remove battery toward the top.

## 14.2 Installing the battery (All XC models)

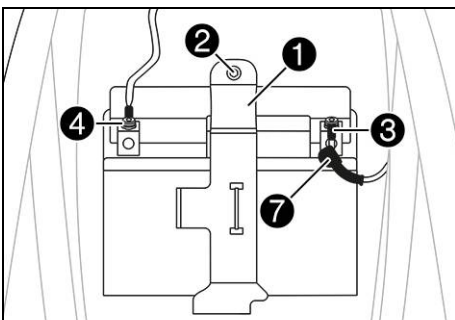

### Main work

- Position the battery in the battery compartment with the terminals facing forward, and secure with holding bracket ①.

Battery (HJTZ5S-FP) (📖 p. 114)

- Mount and tighten screw ②.

#### Guideline

|                           |    |                    |
|---------------------------|----|--------------------|
| Remaining screws, chassis | M6 | 10 Nm (7.4 lbf ft) |
|---------------------------|----|--------------------|

- Connect positive cable ③ to the battery.

#### Guideline

|                         |    |                         |
|-------------------------|----|-------------------------|
| Screw, battery terminal | M5 | 2.5 Nm<br>(1.84 lbf ft) |
|-------------------------|----|-------------------------|

Contact disks **A** must be mounted under screws ⑤ and cable sockets ⑥ with the claws toward the battery terminal.

- Slide positive terminal cover ⑦ over the positive terminal.
- Connect negative cable ④ to the battery.

#### Guideline

|                         |    |                         |
|-------------------------|----|-------------------------|
| Screw, battery terminal | M5 | 2.5 Nm<br>(1.84 lbf ft) |
|-------------------------|----|-------------------------|

### Finishing work

- Mount the seat. (📖 p. 53)

## 14.3 Recharging the battery ↘ (All XC models)

**Warning**  
**Risk of injury** Batteries contain harmful substances.

- Keep batteries out of the reach of children.
- Keep sparks and open flames away from the batteries.
- Only charge batteries in well-ventilated rooms.
- Maintain a minimum clearance from inflammable materials when charging batteries.  
 Minimum clearance 1 m (3 ft)
- Do not charge deeply discharged batteries if charge is already below the minimum voltage.  
 Minimum voltage before the start of the charge 9 V
- Dispose of batteries with less than the minimum voltage correctly.

**Warning**  
**Environmental hazard** Batteries contain environmentally-hazardous materials.

- Do not dispose of batteries as household waste.
- Dispose of batteries at a collection point for used batteries.

**Warning**  
**Environmental hazard** Hazardous substances cause environmental damage.

- Dispose of oils, grease, filters, fuel, cleaning agents, brake fluid, etc., correctly and in compliance with the applicable regulations.

**i Info**  
 Even when there is no load on the battery, it discharges steadily.  
 The charging level and the method of charging are very important for the service life of the battery.  
 Rapid recharging with a high charging current shortens the service life of the battery.  
 If the charging current, charging voltage, or charging time are exceeded, the battery will be destroyed.  
 If the battery is depleted by repeated starting, the battery must be charged immediately.  
 If the battery is left in a discharged state for an extended period, it will become over-discharged and sulfated, destroying the battery.  
 The battery is maintenance-free.

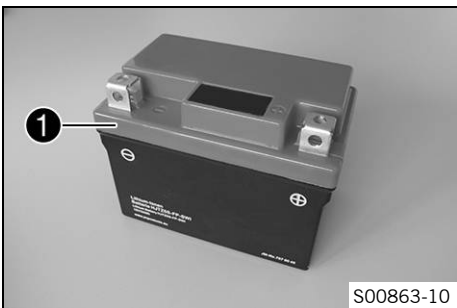

- Preparatory work**
- Press and hold the kill switch ☒ while the engine is idling until the engine stops.
  - Remove the seat. (📖 p. 52)
  - Remove the battery. ↘ (📖 p. 81)

- Main work**
- Check the battery voltage.
    - » Battery voltage: < 9 V
      - Do not charge the battery.
      - Replace the battery and dispose of the old battery properly.
    - » If the specifications have been met:  
 Battery voltage: ≥ 9 V
      - Recharge the battery.

**Guideline**

|   |          |
|---|----------|
| The charging current, charging voltage, and charging duration must not be exceeded. |          |
| Maximum charging voltage  | 14.4 V   |
| Maximum charging current  | 3.0 A    |
| Maximum charging time   | 24 h     |
| Charge the battery regularly when the motorcycle is not in use                      | 6 months |

**i Info**  
 Never remove cover ❶.

- Connect the battery charger to the battery. Switch on the battery charger.

Battery charger (58429074000)

In addition, this battery charger can be used to test the quiescent current, the start ability of the battery, and the alternator. With this device, you cannot overcharge the battery. The charging time may be longer at low temperatures.

- Switch off the battery charger after charging and disconnect from the battery.

**Finishing work**

- Install the battery. (📖 p. 81)
- Mount the seat. (📖 p. 53)

## 14.4 Changing the main fuse (All XC models)

**Warning**

**Fire hazard** Incorrect fuses overload the electrical system.

- Only use fuses with the required ampere value.
- Do not bypass or repair fuses.

**Info**

The main fuse protects all power consumers of the vehicle. It is located in the starter relay housing under the seat.

**Preparatory work**

- Press and hold the kill switch ☒ while the engine is idling until the engine stops.
- Remove the seat. (📖 p. 52)

**Main work**

- Pull starter relay ❶ from the holder.

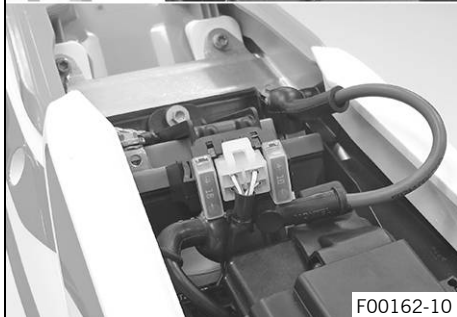
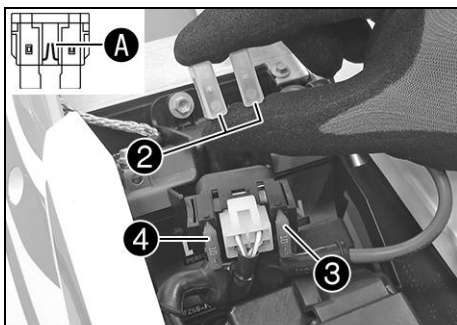
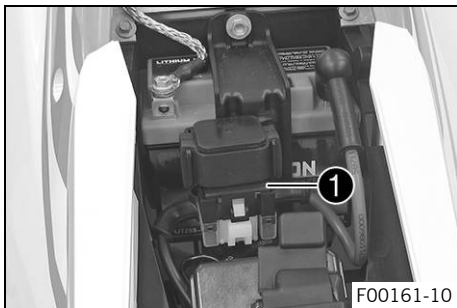

- Take off protection caps ❷.
- Remove faulty main fuse ❸.

**Info**

You can recognize a faulty fuse by a burned-out fuse wire A. A spare fuse ❹ is located in the starter relay.

- Install a new main fuse.

Fuse (58011109110) (📖 p. 114)

- Check that the electrical equipment is functioning properly.

**Tip**

Insert a spare fuse so that it is available if needed.

- Mount the protection caps.
- Mount the starter relay onto the holder and route the cable.

**Finishing work**

- Mount the seat. (📖 p. 53)

## 15.1 Cooling system

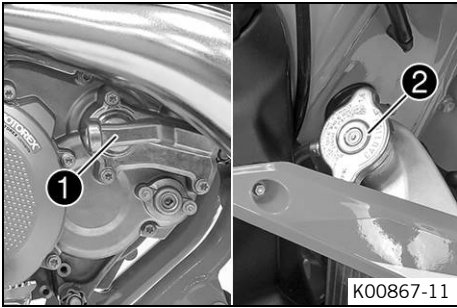

**(All SX models)**

Water pump ① in the engine ensures forced circulation of the coolant. The pressure resulting from the warming of the cooling system is regulated by a valve in radiator cap ②. This ensures that operating the vehicle at the specified coolant temperature will not result in a risk of malfunctions.

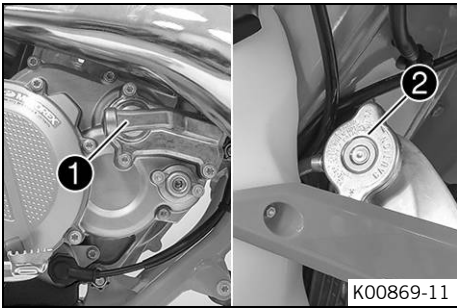

**(All XC models)**

Water pump ① in the engine ensures forced circulation of the coolant. The pressure resulting from the warming of the cooling system is regulated by a valve in radiator cap ②. This ensures that operating the vehicle at the specified coolant temperature will not result in a risk of malfunctions.

## 15.2 Checking the antifreeze and coolant level

- Warning**  
**Danger of scalding** During motorcycle operation, the coolant gets very hot and is under pressure.
- Do not open the radiator, the radiator hoses or other cooling system components if the engine or the cooling system are at operating temperature.
  - Allow the cooling system and the engine to cool down before you open the radiator, the radiator hoses or other components of the cooling system.
  - In the event of scalding, rinse the area affected immediately with lukewarm water.

- Warning**  
**Danger of poisoning** Coolant is toxic and a health hazard.
- Keep coolant out of the reach of children.
  - Do not allow coolant to come into contact with the skin, the eyes and clothing.
  - Consult a doctor immediately if coolant is swallowed.
  - Rinse the affected area immediately with plenty of water in the event of contact with the skin.
  - Rinse eyes thoroughly with water and consult a doctor immediately if coolant gets into the eyes.
  - Change clothing if coolant spills onto your clothing.

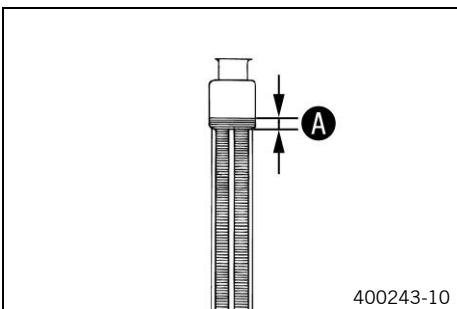

**Condition**

The engine is cold.

- Stand the motorcycle upright on a horizontal surface.
- Remove the radiator cap.
- Check the coolant antifreeze.

|                               |
|-------------------------------|
| -25... -45 °C (-13... -49 °F) |
|-------------------------------|

- » If the antifreeze in the coolant does not match the specified value:
  - Correct the coolant antifreeze.

- Check the coolant level in the radiator.

|   |                 |
|---|-----------------|
| Coolant level ① above the radiator fins | 10 mm (0.39 in) |
|---|-----------------|

- » If the coolant level does not match the specified value:
  - Correct the coolant level.

|                     |
|---------------------|
| Coolant (🗨️ p. 119) |
|---------------------|

- Mount the radiator cap.

## 15.3 Checking the coolant level

**Warning**  
**Danger of scalding** During motorcycle operation, the coolant gets very hot and is under pressure.

- Do not open the radiator, the radiator hoses or other cooling system components if the engine or the cooling system are at operating temperature.
- Allow the cooling system and the engine to cool down before you open the radiator, the radiator hoses or other components of the cooling system.
- In the event of scalding, rinse the area affected immediately with lukewarm water.

**Warning**  
**Danger of poisoning** Coolant is toxic and a health hazard.

- Keep coolant out of the reach of children.
- Do not allow coolant to come into contact with the skin, the eyes and clothing.
- Consult a doctor immediately if coolant is swallowed.
- Rinse the affected area immediately with plenty of water in the event of contact with the skin.
- Rinse eyes thoroughly with water and consult a doctor immediately if coolant gets into the eyes.
- Change clothing if coolant spills onto your clothing.

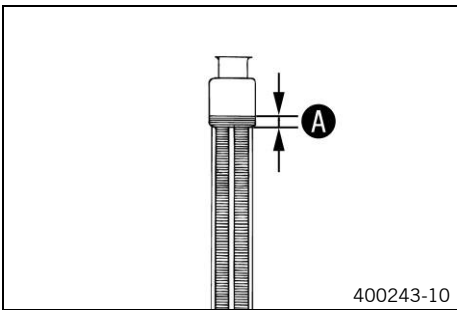

**Condition**  
 The engine is cold.

- Stand the motorcycle upright on a horizontal surface.
- Remove the radiator cap.
- Check the coolant level in the radiator.

|  |                 |
|--|-----------------|
| Coolant level <b>A</b> above the radiator fins | 10 mm (0.39 in) |
|--|-----------------|

» If the coolant level does not match the specified value:

- Correct the coolant level.

|                    |
|--------------------|
| Coolant (📖 p. 119) |
|--------------------|

- Mount the radiator cap.

## 15.4 Draining the coolant

**Warning**  
**Danger of scalding** During motorcycle operation, the coolant gets very hot and is under pressure.

- Do not open the radiator, the radiator hoses or other cooling system components if the engine or the cooling system are at operating temperature.
- Allow the cooling system and the engine to cool down before you open the radiator, the radiator hoses or other components of the cooling system.
- In the event of scalding, rinse the area affected immediately with lukewarm water.

**Warning**  
**Danger of poisoning** Coolant is toxic and a health hazard.

- Keep coolant out of the reach of children.
- Do not allow coolant to come into contact with the skin, the eyes and clothing.
- Consult a doctor immediately if coolant is swallowed.
- Rinse the affected area immediately with plenty of water in the event of contact with the skin.
- Rinse eyes thoroughly with water and consult a doctor immediately if coolant gets into the eyes.
- Change clothing if coolant spills onto your clothing.

**Condition**  
 The engine is cold.

- Position the motorcycle upright.

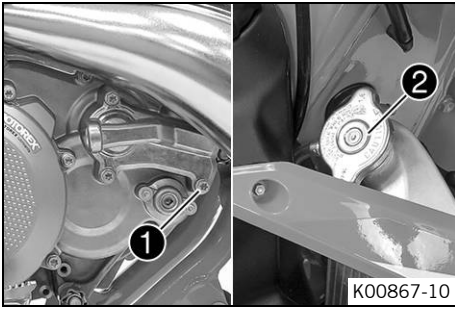

- Place a suitable container under the water pump cover.

**(All SX models)**

- Remove screw ①. Take off radiator cap ②.
- Completely drain the coolant.
- Mount and tighten screw ① with a new seal ring.

Guideline

|                         |    |                       |
|-------------------------|----|-----------------------|
| Screw, water pump cover | M6 | 10 Nm<br>(7.4 lbf ft) |
|-------------------------|----|-----------------------|

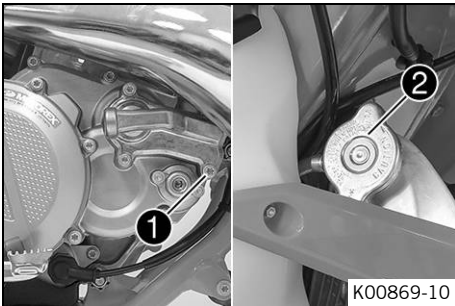

**(All XC models)**

- Remove screw ①. Take off radiator cap ②.
- Completely drain the coolant.
- Mount and tighten screw ① with a new seal ring.

Guideline

|                         |    |                       |
|-------------------------|----|-----------------------|
| Screw, water pump cover | M6 | 10 Nm<br>(7.4 lbf ft) |
|-------------------------|----|-----------------------|

## 15.5 Refilling with coolant ↩



**Warning**

**Danger of poisoning** Coolant is toxic and a health hazard.

- Keep coolant out of the reach of children.
- Do not allow coolant to come into contact with the skin, the eyes and clothing.
- Consult a doctor immediately if coolant is swallowed.
- Rinse the affected area immediately with plenty of water in the event of contact with the skin.
- Rinse eyes thoroughly with water and consult a doctor immediately if coolant gets into the eyes.
- Change clothing if coolant spills onto your clothing.

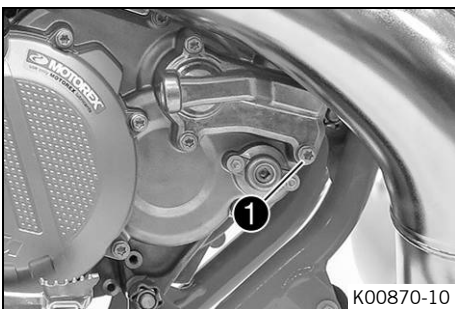

**(All SX models)**

- Make sure that screw ① is tightened.
- Position the motorcycle upright.
- Completely fill the radiator with coolant.

|                    |
|--------------------|
| Coolant (📖 p. 119) |
|--------------------|



- Loosen screw ② until coolant escapes without bubbles.
- Mount and tighten screw ②.

Guideline

|                              |    |                       |
|------------------------------|----|-----------------------|
| Bleeder screw, cylinder head | M6 | 10 Nm<br>(7.4 lbf ft) |
|------------------------------|----|-----------------------|

- Completely fill the radiator with coolant.

|                    |
|--------------------|
| Coolant (📖 p. 119) |
|--------------------|



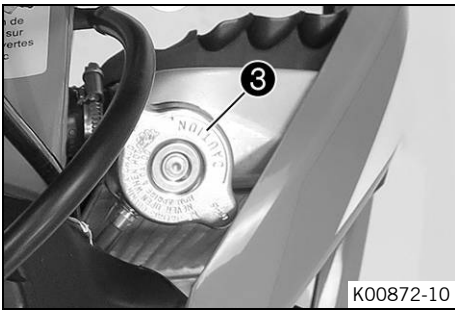

- Mount radiator cap ③.



**Danger**

**Danger of poisoning** Exhaust gases are toxic and inhaling them may result in unconsciousness and death.

- Always make sure there is sufficient ventilation when running the engine.
- Use an effective exhaust extraction system when starting or running the engine in an enclosed space.

- Allow the engine to warm up and cool down again.
- Check the coolant level. (📖 p. 85)

**(All XC models)**

- Make sure that screw ① is tightened.
- Position the motorcycle upright.
- Completely fill the radiator with coolant.

Coolant (📖 p. 119)

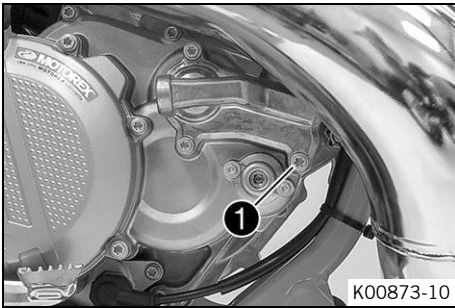

- Loosen screw ② until coolant escapes without bubbles.
- Mount and tighten screw ②.

Guideline

|                              |    |                       |
|------------------------------|----|-----------------------|
| Bleeder screw, cylinder head | M6 | 10 Nm<br>(7.4 lbf ft) |
|------------------------------|----|-----------------------|

- Completely fill the radiator with coolant.

Coolant (📖 p. 119)

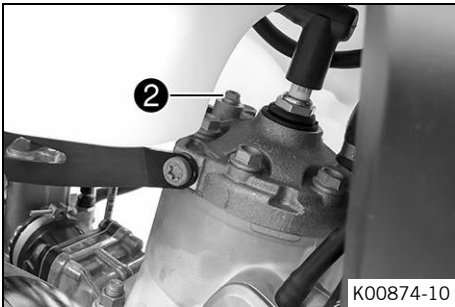

- Mount radiator cap ③.



**Danger**

**Danger of poisoning** Exhaust gases are toxic and inhaling them may result in unconsciousness and death.

- Always make sure there is sufficient ventilation when running the engine.
- Use an effective exhaust extraction system when starting or running the engine in an enclosed space.

- Allow the engine to warm up and cool down again.
- Check the coolant level. (📖 p. 85)



## 16.1 Checking the play in the throttle cable

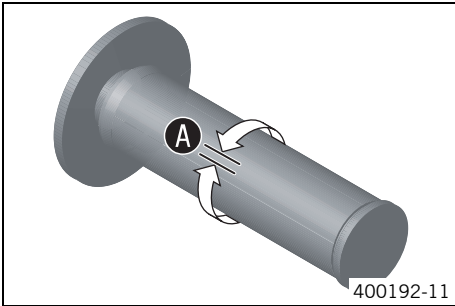

- Check the throttle grip for smooth operation.
- Move the handlebar to the straight-ahead position. Move the throttle grip back and forth slightly to determine the play in throttle cable **A**.

|                        |                             |
|------------------------|-----------------------------|
| Play in throttle cable | 2... 3 mm (0.08... 0.12 in) |
|------------------------|-----------------------------|

- » If the throttle cable play does not meet specifications:
  - Adjust the play in the throttle cable. 🛠️ (p. 88)



### Danger

**Danger of poisoning** Exhaust gases are toxic and inhaling them may result in unconsciousness and death.

- Always make sure there is sufficient ventilation when running the engine.
- Use an effective exhaust extraction system when starting or running the engine in an enclosed space.

- Start the engine and let it run idle. Move the handlebar to and fro over the entire steering range.

|                                 |
|---------------------------------|
| The idle speed must not change. |
|---------------------------------|

- » If the idle speed changes:
  - Adjust the play in the throttle cable. 🛠️ (p. 88)

## 16.2 Adjusting the play in the throttle cable 🛠️



### Info

If the correct routing of the throttle cable has already been secured, the fuel tank does not need to be removed.

### Preparatory work

- Remove the seat. 🛠️ (p. 52)

### (All SX models)

- Turn handle **1** of the fuel tap to the **OFF** position. (Figure A00016-10 🛠️ p. 15)

### (All XC models)

- Turn handle **1** of the fuel tap to the **OFF** position. (Figure A00023-10 🛠️ p. 15)

- Remove the fuel tank. 🛠️ (p. 57)
- Check the throttle cable routing. 🛠️ (p. 63)

### Main work

- Move the handlebar to the straight-ahead position.
- Push back sleeve **1**.
- Ensure that the throttle cable sleeve is pushed all the way into barrel adjuster **2**.
- Loosen nut **3**.

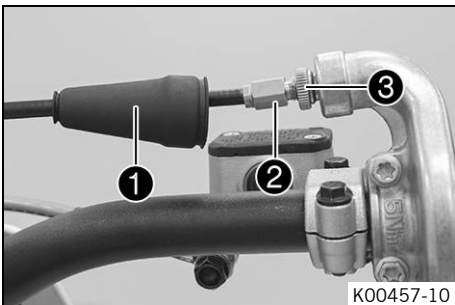

- Turn barrel adjuster **2** so that there is play **A** in the throttle cable at the throttle grip.

### Guideline

|                        |                             |
|------------------------|-----------------------------|
| Play in throttle cable | 2... 3 mm (0.08... 0.12 in) |
|------------------------|-----------------------------|

- Tighten nut **3**.
- Slide on sleeve **1**.

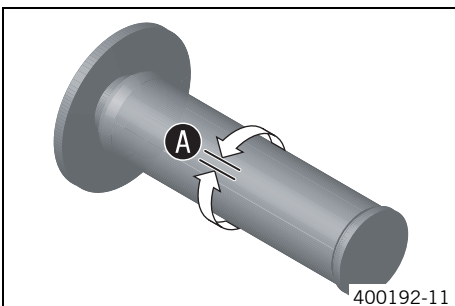

**Finishing work**

- Check the throttle grip for smooth operation.
- Install the fuel tank. (📖 p. 58)
- Mount the seat. (📖 p. 53)
- Check the play in the throttle cable. (📖 p. 88)

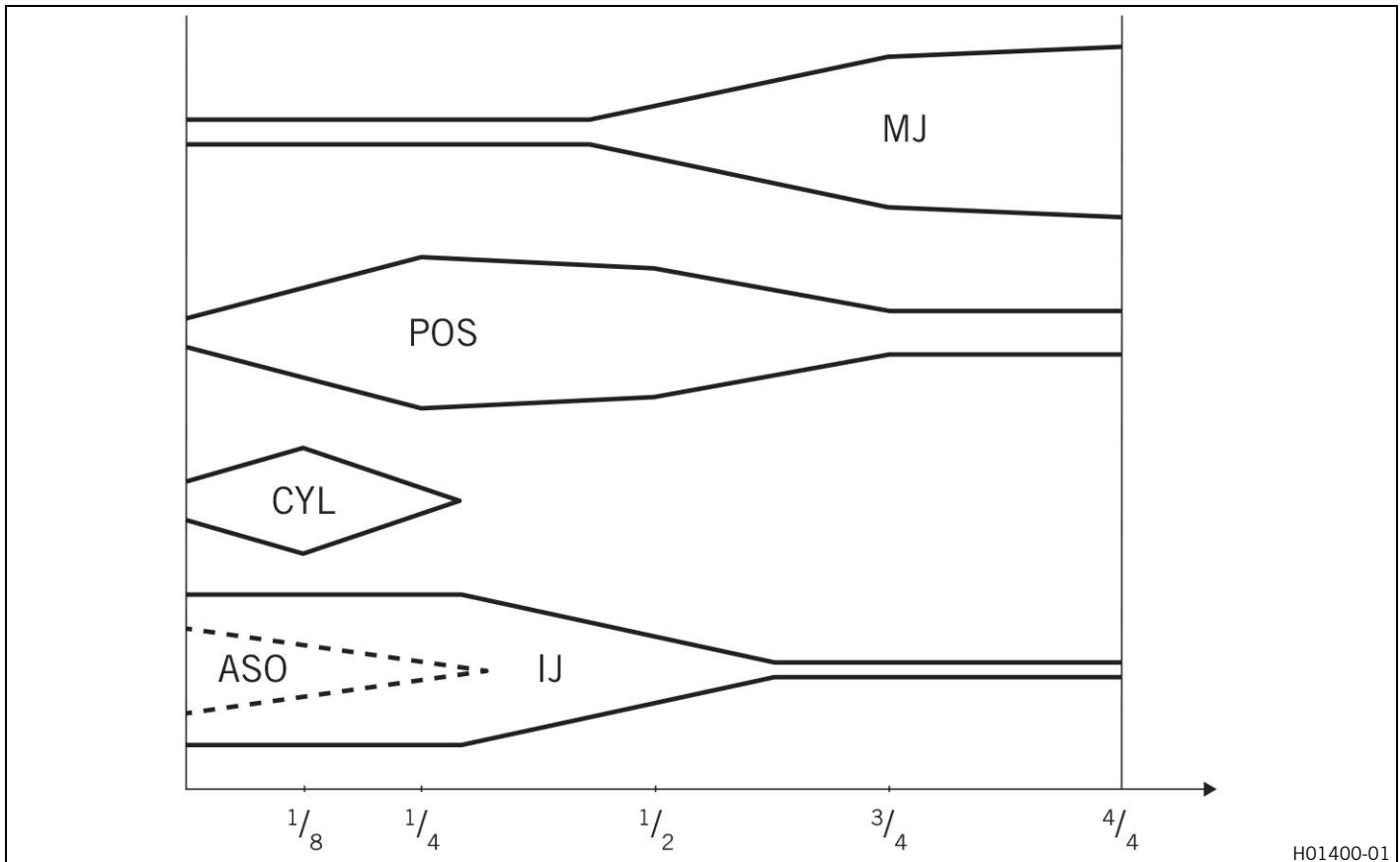
**16.3 Carburetor setting****Effects of the carburetor setting**

H01400-01

The different carburetor components must be tuned both to one another and for the use intended.

**Main jet MJ**

The main jet MJ has the greatest influence with the throttle slide open (full throttle).

If the insulator of a new spark plug is very light or white after a brief ride at full throttle, or if the engine knocks, a larger main jet needs to be used. If the insulator is dark brown or sooty, a smaller main jet needs to be used.

**Needle position POS**

The needle position has the greatest influence in the mid throttle slide range.

If the engine stutters when accelerating with a partially open throttle slide, the jet needle must be lowered. If the engine knocks when accelerating at the full power rpm range, the jet needle must be raised.

**Cylindrical part of the needle CYL**

The cylindrical part of the needle has the greatest influence when the throttle slide is almost closed.

**Idling jet IJ**

The idling jet has the greatest influence in the low to mid throttle slide range.

If the engine stutters when idling or accelerating with a partially open throttle slide, a smaller idling jet must be used. If the engine knocks in this power range, then a larger idling jet must be used.

**Idle air adjusting screw open ASO**

The idle air adjusting screw has the greatest influence during idling.

## Influence of throttle slide adjustment

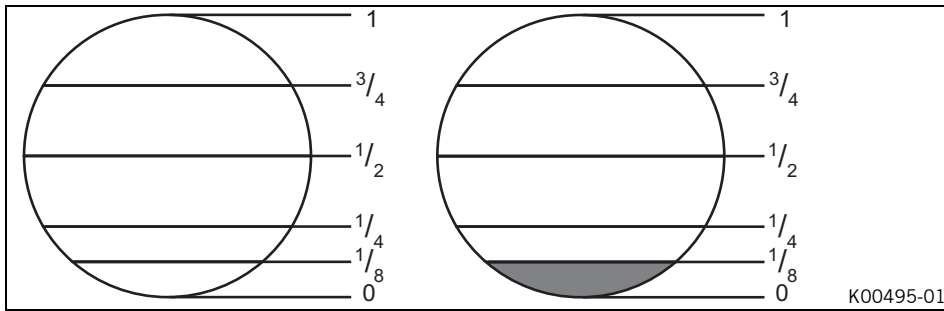

The idling jet has the greatest influence when the throttle slide is closed. The first cylindrical part of the needle and the clip position have only minimal influence.

When the throttle slide is 1/8 open, the first cylindrical part of the needle, the idling jet and the clip position have the greatest influence.

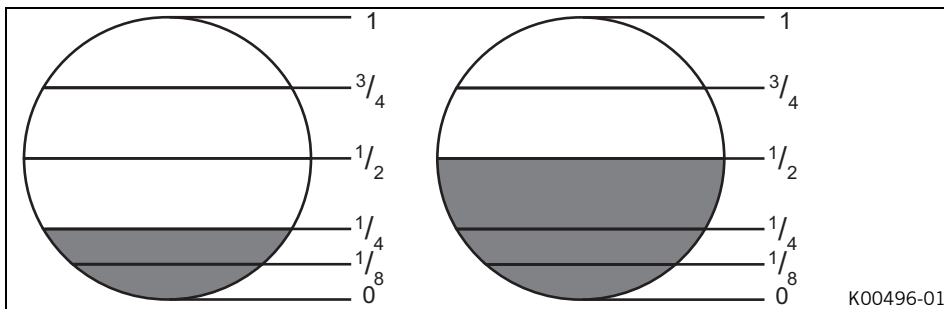

When the throttle slide is 1/4 open, the idling jet and the clip position have the greatest influence. The influence of the first cylindrical part of the needle is less.

When the throttle slide is 1/2 open, the position of the needle has the greatest influence. The influence of the main jet and the idling jet is only minimal.

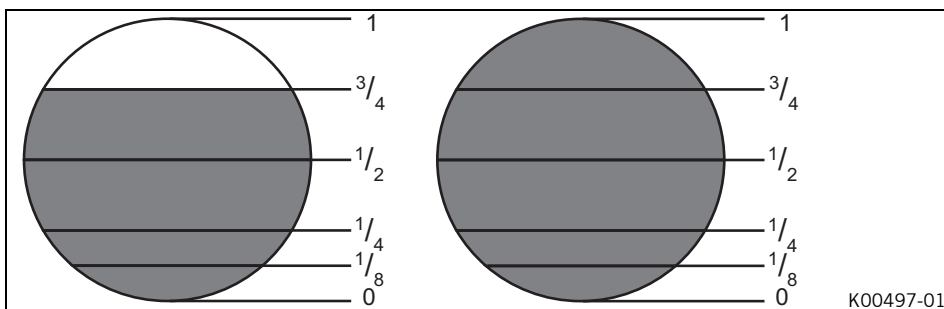

When the throttle slide is 3/4 open, the influence of the main jet is greatest. The clip position and the idling jet have only minimal influence.

When the throttle slide is fully open, the influence of the main jet is greatest. The clip position and the idling jet have only minimal influence.

## Needle overview

The jet needles available are shown in the following table.

|   | 1         | 2         | 3         | 4       |
|---|-----------|-----------|-----------|---------|
| A | 6BFY42-71 | 6BFY43-71 | 6BFY44-71 | 2,71 mm |
| B | 6BFY42-72 | 6BFY43-72 | 6BFY44-72 | 2.72 mm |
| C | 6BFY42-73 | 6BFY43-73 | 6BFY44-73 | 2.73 mm |
| D | 6BFY42-74 | 6BFY43-74 | 6BFY44-74 | 2.74 mm |
| E | 6BFY42-75 | 6BFY43-75 | 6BFY44-75 | 2.75 mm |
| F | 6BFY42-76 | 6BFY43-76 | 6BFY44-76 | 2.76 mm |

402674-01

Column 2 corresponds to a needle in the standard position.

Column 1 corresponds to a needle which is half a clip leaner.

Column 3 corresponds to a needle which is half a clip richer.

Column 4 specifies the diameter of the first cylindrical part of the needle. The smaller the diameter of the first cylindrical part of the needle, the richer the carburation. The larger the diameter of the first cylindrical part of the needle, the leaner the carburation. The first cylindrical part of the needle has the greatest influence in the lowest load adjustment.

**i Info** The top right jet needle **A3** corresponds to the richest setting of the carburetor, and the bottom left jet needle **F1** corresponds to the leanest. The optimal carburetor tuning is shown under the respective model.

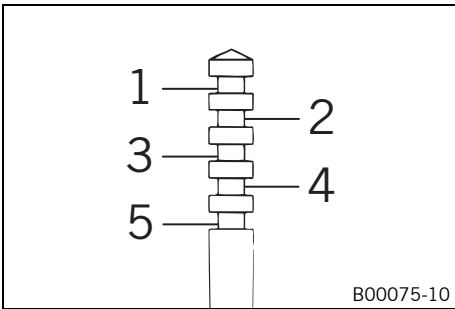

**Clip position**

|        |                          |
|--------|--------------------------|
| 1... 5 | Clip position from above |
|--------|--------------------------|

The five possible clip positions are shown here. The carburetor tuning depends on the defined ambient and operating conditions.

## 16.4 Carburetor – idle

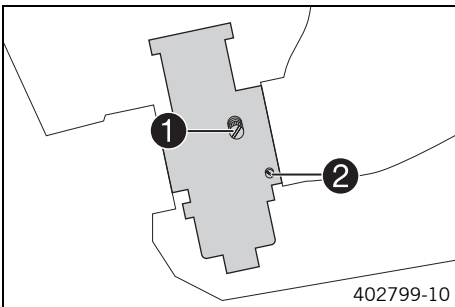

The idle setting of the carburetor has a big influence on the starting behavior, stable idling, and the response to throttle opening. This means that an engine with a correctly set idle speed is easier to start than if the idle speed is set wrongly.

**i Info** The carburetor and its components are subject to increased wear caused by engine vibration. Wear can result in malfunctioning.

The factory setting for the carburetor is set for the following values.

|   |                                |
|---|--------------------------------|
| Height above sea level  | 301... 750 m (988... 2,461 ft) |
| Ambient temperature   | 6... 15 °C (43... 59 °F)       |
| Super unleaded (95 octane) mixed with 2-stroke engine oil (1:60) (📖 p. 120) |                                |

The idle speed is adjusted with adjusting screw **1**.  
The idle mixture is adjusted using the idle air adjusting screw **2**.

## 16.5 Carburetor – adjusting the idle speed ↘

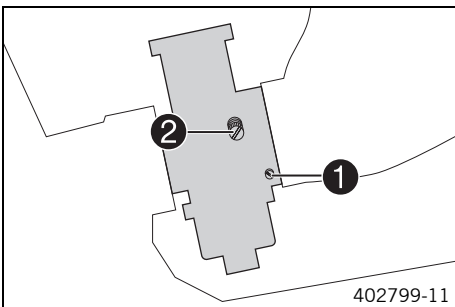

- Screw in idle air adjusting screw **1** all the way and turn it to the specified basic position.

**i Info** The basic adjustment is shown under the respective model.

- Run the engine until warm.

**Guideline**

|              |         |
|--------------|---------|
| Warm-up time | ≥ 5 min |
|--------------|---------|

**⚠ Danger**  
**Danger of poisoning** Exhaust gases are toxic and inhaling them may result in unconsciousness and death.

- Always make sure there is sufficient ventilation when running the engine.
- Use an effective exhaust extraction system when starting or running the engine in an enclosed space.

- Adjust the idle speed with adjusting screw **2**.

**Guideline**

|  |                    |
|--|--------------------|
| Choke function deactivated – The choke lever is pushed in to the stop. (📖 p. 16) |                    |
| Idle speed   | 1,400... 1,500 rpm |

- Turn idle air adjusting screw **1** slowly in a clockwise direction until the idle speed begins to fall.
- Note the position and turn the idle air adjusting screw slowly counterclockwise until the idle speed again begins to fall.

- Adjust to the point between these two positions with the highest idle speed.



**Info**

If there is a big engine speed rise, reduce the idle speed to a normal level and repeat the above steps.  
 If the procedure described here does not lead to satisfactory results, the cause may be a wrongly dimensioned idling jet.  
 If you can turn the idle air adjusting screw to the end without any change of engine speed, mount a smaller idling jet.  
 After changing the jet, start from the beginning with the adjusting steps.  
 Following extreme air temperature or altitude changes, adjust the idle speed again.

## 16.6 Plug-in connector of ignition timing map adjustment

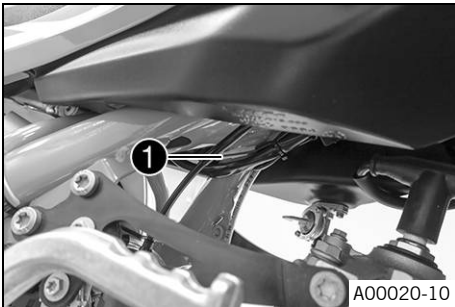

**(All SX models)**

Plug-in connector ① of the ignition timing map adjustment is located on the frame under the fuel tank.



**(All XC models)**

Plug-in connector ① of the ignition timing map adjustment is located on the frame under the fuel tank.

**Possible states**

**(All SX models)**

- Soft – The plug-in connector of the ignition timing map adjustment is disconnected to achieve better rideability.
- Performance – The plug-in connector of the ignition timing map adjustment is joined to achieve higher performance.

**(All XC models)**

- Soft – The plug-in connector of the ignition timing map adjustment is disconnected to achieve better rideability.
- Performance – The plug-in connector of the ignition timing map adjustment is joined to achieve higher performance.

## 16.7 Changing the ignition timing map

**Switch the ignition timing map from Performance to Soft**

**(All XC models)**

- Disconnect plug-in connector ① of the ignition timing map adjustment. (Figure K00509-10 p. 92)
- ✓ Soft – better rideability

**Switch the ignition timing map from Soft to Performance**

**(All XC models)**

- Join plug-in connector ① of the ignition timing map adjustment. (Figure K00509-10 p. 92)
- ✓ Performance – better performance

## 16.8 Checking the basic position of the shift lever



**Info**

When driving, the shift lever must not touch the rider's boot when in the basic position.  
 When the shift lever keeps touching the boot, the transmission will be subject to an excessive load.

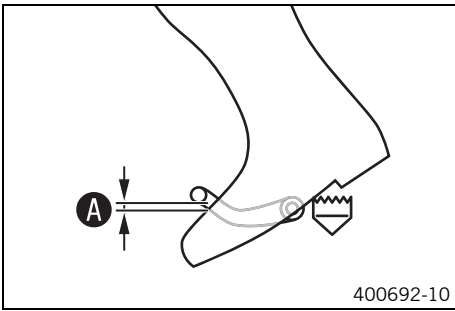

- Sit on the vehicle in the riding position and determine distance **A** between the upper edge of your boot and the shift lever.

|   |                               |
|---|-------------------------------|
| Distance between shift lever and upper edge of boot | 10... 20 mm (0.39... 0.79 in) |
|---|-------------------------------|

- » If the distance does not meet specifications:
  - Adjust the basic position of the shift lever. 🛠️ (p. 93)

## 16.9 Adjusting the basic position of the shift lever 🛠️

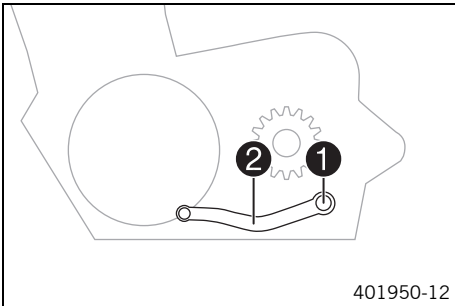

- Remove screw **1** with the washers and take off shift lever **2**.

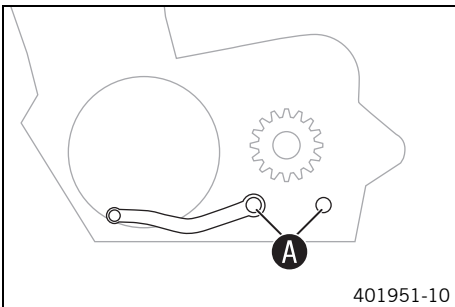

- Clean gear teeth **A** of the shift lever and shift shaft.
- Mount the shift lever on the shift shaft in the required position and engage the gearing.

**i Info**  
 The range of adjustment is limited.  
 The shift lever must not come into contact with any other vehicle components during the shift procedure.

- Mount and tighten screw **1** with washers.

Guideline

|                                    |    |                     |               |
|------------------------------------|----|---------------------|---------------|
| Screw, shift lever (All SX models) | M6 | 14 Nm (10.3 lbf ft) | Loctite® 243™ |
| Screw, shift lever (All XC models) | M6 | 14 Nm (10.3 lbf ft) | Loctite® 243™ |

## 16.10 Engine characteristic – auxiliary spring

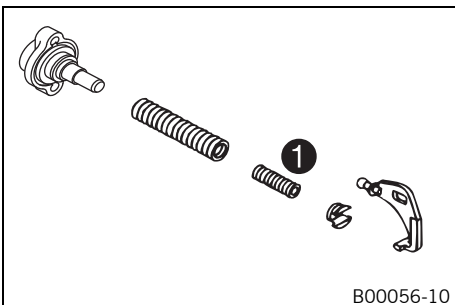

The auxiliary spring is located on the right side of the engine below the water pump cover.

**Possible states**

- Auxiliary spring with yellow marking – Auxiliary spring mounted at the factory with medium tuning (standard) for good rideability.
- Auxiliary spring with green marking – Auxiliary spring for even softer performance.
- Auxiliary spring with red marking – Auxiliary spring for aggressive performance.

The engine characteristic can be influenced by different spring strengths of auxiliary spring **1**.

## 16.11 Engine characteristic – setting the auxiliary spring 🛠️

**⚠ Warning**  
**Danger of burns** Some vehicle components become very hot when the vehicle is operated.

- Do not touch any parts such as the exhaust system, radiator, engine, shock absorber, or brake system before the vehicle parts have cooled down.
- Let the vehicle parts cool down before you perform any work on the vehicle.

### Preparatory work

- Tilt the motorcycle to the left and secure against falling in this position.

#### Guideline

|                        |     |
|------------------------|-----|
| Angle of title approx. | 45° |
|------------------------|-----|

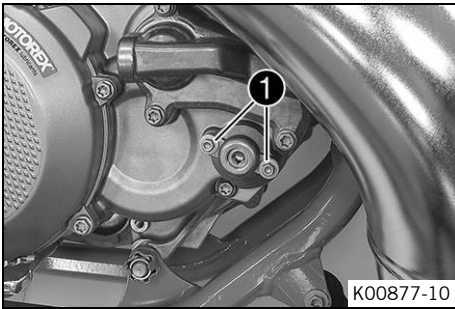

### Main work

#### (All SX models)

- Remove screws 1.

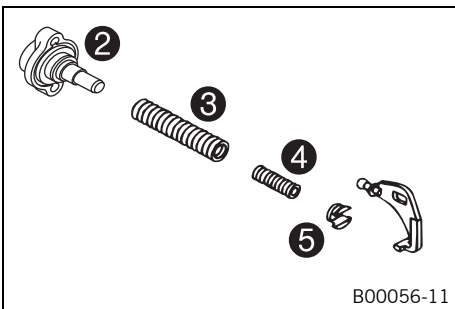

- Remove cap 2, adjusting spring 3, auxiliary spring 4, and spring insert 5 from the clutch cover.
- Pull both springs off of the spring insert.

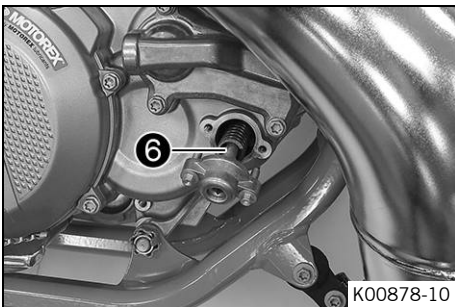

- Mount the required auxiliary spring 4 and adjusting spring 3 and position them together in the clutch cover.

|  |
|--|
| Auxiliary spring with yellow marking (54637072300) |
| Auxiliary spring with green marking (54837072100)  |
| Auxiliary spring with red marking (54837072000)    |

- ✓ The recess in spring insert 5 engages in the angle lever.

#### **i** Info

Screw 6 must not be turned as this would worsen the engine characteristic.

- Check the O-ring in the cap.
- Position the cap.
- Mount and tighten the screws.

#### Guideline

|                              |    |                    |               |
|------------------------------|----|--------------------|---------------|
| Screw, exhaust control cover | M5 | 4 Nm<br>(3 lbf ft) | Loctite® 222™ |
|------------------------------|----|--------------------|---------------|

#### (All XC models)

- Remove screws 1.

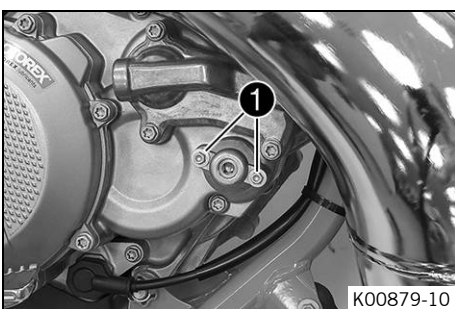



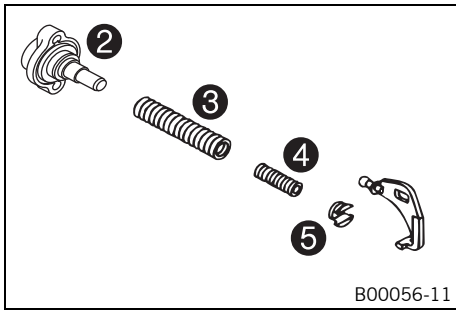

- Remove cap ②, adjusting spring ③, auxiliary spring ④, and spring insert ⑤ from the clutch cover.
- Pull both springs off of the spring insert.

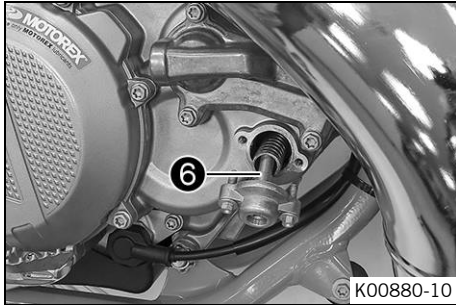

- Mount the required auxiliary spring ④ and adjusting spring ③ and position them together in the clutch cover.

|  |
|--|
| Auxiliary spring with yellow marking (54637072300) |
| Auxiliary spring with green marking (54837072100)  |
| Auxiliary spring with red marking (54837072000)    |

- ✓ The recess in spring insert ⑤ engages in the angle lever.

**i Info**  
Screw ⑥ must not be turned as this would worsen the engine characteristic.

- Check the O-ring in the cap.
- Position the cap.
- Mount and tighten the screws.

Guideline

|                              |    |                    |                      |
|------------------------------|----|--------------------|----------------------|
| Screw, exhaust control cover | M5 | 4 Nm<br>(3 lbf ft) | <b>Loctite® 222™</b> |
|------------------------------|----|--------------------|----------------------|

## 17.1 Emptying the carburetor float chamber



### Danger

**Fire hazard** Fuel is highly flammable.

The fuel in the fuel tank expands when warm and can escape if overfilled.

- Do not refuel the vehicle in the vicinity of open flames or lit cigarettes.
- Switch off the engine for refueling.
- Make sure that no fuel is spilled; particularly not on hot parts of the vehicle.
- If any fuel is spilled, wipe it off immediately.
- Observe the specifications for refueling.



### Warning

**Danger of poisoning** Fuel is poisonous and a health hazard.

- Avoid skin, eye and clothing contact with fuel.
- Immediately consult a doctor if you swallow fuel.
- Do not inhale fuel vapors.
- In case of skin contact, rinse the affected area with plenty of water.
- Rinse the eyes thoroughly with water, and consult a doctor in case of fuel contact with the eyes.
- Change your clothing in case of fuel spills on them.
- Keep fuels correctly in a suitable canister, and out of the reach of children.



### Warning

**Environmental hazard** Improper handling of fuel is a danger to the environment.

- Do not allow fuel to enter the groundwater, the soil, or the sewage system.



### Info

Carry out this work with a cold engine.

Water in the float chamber results in malfunctioning.

### Preparatory work

#### (All SX models)

- Turn handle ❶ of the fuel tap to the **OFF** position.  
(Figure A00016-10  p. 15)
- ✓ Fuel no longer flows from the fuel tank to the carburetor.

#### (All XC models)

- Turn handle ❶ of the fuel tap to the **OFF** position.  
(Figure A00023-10  p. 15)
- ✓ Fuel no longer flows from the fuel tank to the carburetor.

### Main work

- Place a cloth under the carburetor to capture the draining fuel.
- Remove screw plug ❶.
- Fully drain the fuel.
- Mount and tighten the screw plug.

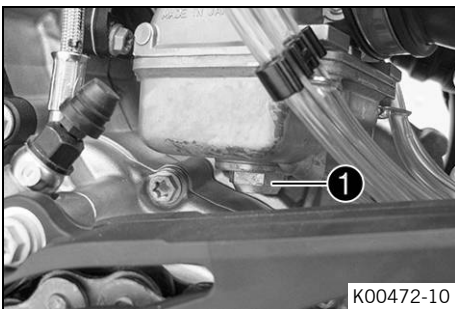

## 17.2 Checking the gear oil level



**Info**  
The gear oil level must be checked when the engine is cold.

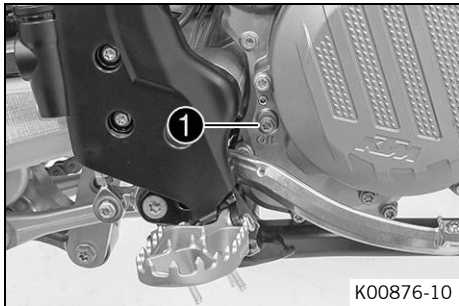

**Preparatory work**

- Stand the motorcycle upright on a horizontal surface.

**Main work**

- Detach the foot brake lever spring.
- Remove gear oil level check screw ❶.
- Check the gear oil level.

A small quantity of gear oil must run out of the drilled hole.

- » If no gear oil runs out:
  - Add gear oil. 🛠️ (📖 p. 98)

- Mount and tighten the gear oil monitoring screw.

**Guideline**

|   |    |                    |
|---|----|--------------------|
| Screw, gear oil level check (All SX models) | M6 | 10 Nm (7.4 lbf ft) |
| Screw, gear oil level check (All XC models) | M6 | 10 Nm (7.4 lbf ft) |

- Attach the foot brake lever spring.

## 17.3 Changing the gear oil 🛠️



**Warning**  
**Danger of scalding** Engine and gear oil get very hot when the motorcycle is ridden.

- Wear suitable protective clothing and safety gloves.
- In the event of scalding, rinse the area affected immediately with lukewarm water.



**Warning**  
**Environmental hazard** Hazardous substances cause environmental damage.

- Dispose of oils, grease, filters, fuel, cleaning agents, brake fluid, etc., correctly and in compliance with the applicable regulations.



**Info**  
Drain the gear oil while the engine is at operating temperature.

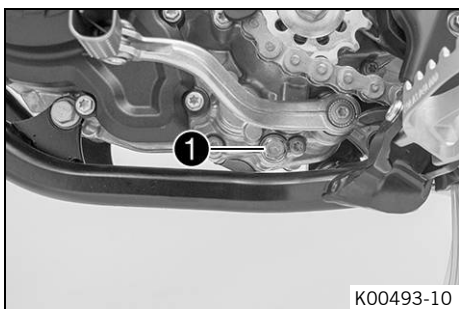

**Preparatory work**

- Park the motorcycle on a level surface.
- Place a suitable container under the engine.

**Main work**

- Remove the gear oil drain plug with magnet ❶.
- Let the gear oil drain fully.
- Thoroughly clean the gear oil drain plug with magnet.
- Clean the sealing surface on the engine.
- Mount and tighten gear oil drain plug with the magnet ❶ and the new seal ring.

**Guideline**

|   |         |                     |
|---|---------|---------------------|
| Gear oil drain plug with magnet (All SX models) | M12x1.5 | 20 Nm (14.8 lbf ft) |
| Gear oil drain plug with magnet (All XC models) | M12x1.5 | 20 Nm (14.8 lbf ft) |

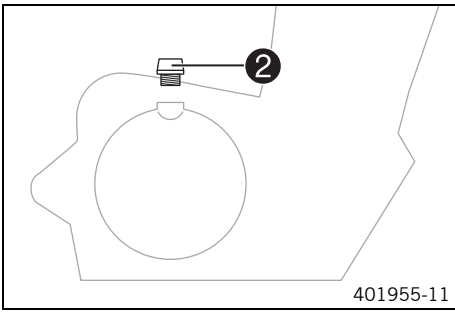

- Remove filler plug ② and fill up with gear oil.

|          |                   |                                |
|----------|-------------------|--------------------------------|
| Gear oil | 0.80 l (0.85 qt.) | Engine oil (15W/50) (📖 p. 119) |
|----------|-------------------|--------------------------------|

- Mount and tighten the oil filler plug.



**Danger**

**Danger of poisoning** Exhaust gases are toxic and inhaling them may result in unconsciousness and death.

- Always make sure there is sufficient ventilation when running the engine.
- Use an effective exhaust extraction system when starting or running the engine in an enclosed space.

- Start the engine and check that it is oil-tight.

**Finishing work**

- Check the gear oil level. (📖 p. 97)

## 17.4 Adding gear oil 🛠️

**i Info**

Too little gear oil or poor-quality gear oil results in premature wear to the transmission. Gear oil must only be topped up when the engine is cold.

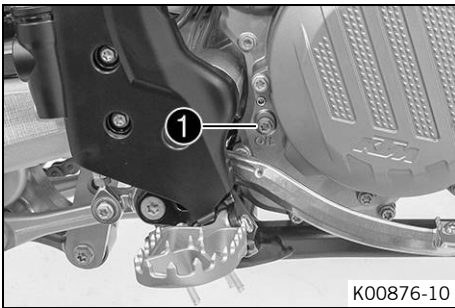

**Preparatory work**

- Park the motorcycle on a level surface.

**Main work**

- Remove gear oil level check screw ①.

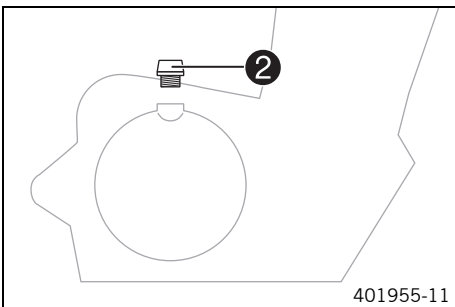

- Remove filler plug ②.

- Add gear oil until it emerges from the drill hole of the gear oil monitoring screw.

|                                |
|--------------------------------|
| Engine oil (15W/50) (📖 p. 119) |
|--------------------------------|

- Mount and tighten the gear oil monitoring screw.

**Guideline**

|   |    |                    |
|---|----|--------------------|
| Screw, gear oil level check (All SX models) | M6 | 10 Nm (7.4 lbf ft) |
| Screw, gear oil level check (All XC models) | M6 | 10 Nm (7.4 lbf ft) |

- Mount and tighten filler plug ②.

**Finishing work**



**Danger**

**Danger of poisoning** Exhaust gases are toxic and inhaling them may result in unconsciousness and death.

- Always make sure there is sufficient ventilation when running the engine.
- Use an effective exhaust extraction system when starting or running the engine in an enclosed space.

- Start the engine and check that it is oil-tight.

## 18.1 Cleaning the motorcycle

**Note**

**Material damage** Components become damaged or destroyed if a pressure cleaner is used incorrectly. The high pressure forces water into the electrical components, connectors, throttle cables, and bearings, etc. Pressure which is too high causes malfunctions and destroys components.

- Do not direct the water jet directly on to electrical components, connectors, throttle cables or bearings.
- Maintain a minimum distance between the nozzle of the pressure cleaner and the component.  
Minimum clearance 60 cm (23.6 in)

 **Warning**

**Environmental hazard** Hazardous substances cause environmental damage.

- Dispose of oils, grease, filters, fuel, cleaning agents, brake fluid, etc., correctly and in compliance with the applicable regulations.

 **Info**

If you clean the motorcycle regularly, its value and appearance will be maintained over a long period. Avoid direct sunlight on the motorcycle during cleaning.

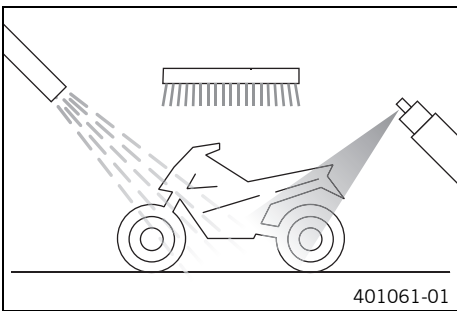

- Close off the exhaust system to prevent water from entering.
- Remove coarse dirt particles by spraying gently with water.
- Spray very dirty areas with a normal motorcycle cleaner and then clean with a soft brush.

Motorcycle cleaner (📖 p. 121)

 **Info**

Use warm water containing normal motorcycle cleaner and a soft sponge. Never apply motorcycle cleaner to the dry vehicle; always rinse with water first.

- After rinsing the motorcycle with a gentle water spray, allow it to dry thoroughly.
- Empty the carburetor float chamber. 📖 (p. 96)
- Remove the plug from the exhaust system.

 **Warning**

**Danger of accidents** Moisture and dirt impair the brake system.

- Brake carefully several times to dry out and remove dirt from the brake linings and the brake discs.

- After cleaning, take a short ride until the engine reaches operating temperature.

 **Info**

The heat produced causes water at inaccessible locations in the engine and brake system to evaporate.

- After the motorcycle has cooled off, lubricate all moving parts and bearings.
- Clean the chain. (📖 p. 60)
- Treat bare metal parts (except for brake discs and exhaust system) with anti-corrosion materials.

Preserving materials for paints, metal and rubber (📖 p. 121)

- Treat all plastic parts and powder-coated parts with a mild cleaning and care product.

Special cleaner for glossy and matte paint finishes, metal and plastic surfaces (📖 p. 121)

## 19.1 Storage

**Warning****Danger of poisoning** Fuel is poisonous and a health hazard.

- Avoid skin, eye and clothing contact with fuel.
- Immediately consult a doctor if you swallow fuel.
- Do not inhale fuel vapors.
- In case of skin contact, rinse the affected area with plenty of water.
- Rinse the eyes thoroughly with water, and consult a doctor in case of fuel contact with the eyes.
- Change your clothing in case of fuel spills on them.
- Keep fuels correctly in a suitable canister, and out of the reach of children.

**Info**

If you plan to garage the motorcycle for a longer period, perform the following steps or have them performed. Before storing the motorcycle, check all parts for function and wear. If service, repairs, or replacements are necessary, you should do this during the storage period (less workshop overload). In this way, you can avoid long workshop waiting times at the start of the new season.

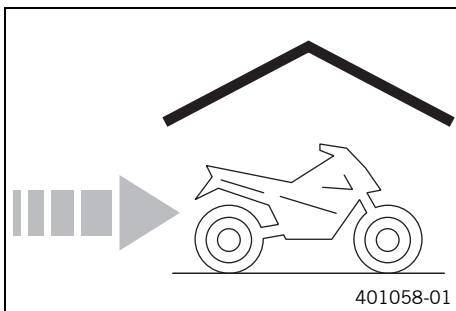

- When refueling for the last time before taking the motorcycle out of service, add fuel additive.

|                          |
|--------------------------|
| Fuel additive (📖 p. 121) |
|--------------------------|

- Refuel. (📖 p. 28)
- Clean the motorcycle. (📖 p. 99)
- Change the gear oil. 🛠️ (📖 p. 97)
- Check the antifreeze and coolant level. (📖 p. 84)
- Empty the carburetor float chamber. 🛠️ (📖 p. 96)
- Check the tire air pressure. (📖 p. 79)

**(All XC models)**

- Remove the battery. 🛠️ (📖 p. 81)

**(All XC models)**

- Recharge the battery. 🛠️ (📖 p. 82)

## Guideline

|  |                          |
|--|--------------------------|
| Storage temperature of battery without direct sunshine | 0... 35 °C (32... 95 °F) |
|--|--------------------------|

- Store the vehicle in a dry location that is not subject to large fluctuations in temperature.

**Info**

KTM recommends jacking up the motorcycle.

- Raise the motorcycle with a lift stand. (📖 p. 42)
- Cover the vehicle with a tarp or similar cover that is permeable to air.

**Info**

Do not use non-porous materials since they prevent humidity from escaping, thus causing corrosion.

Avoid running the engine for a short time only. Because the engine will not warm up sufficiently, the water vapor produced during combustion will condense, causing engine parts and the exhaust system to rust.

## 19.2 Preparing for use after storage

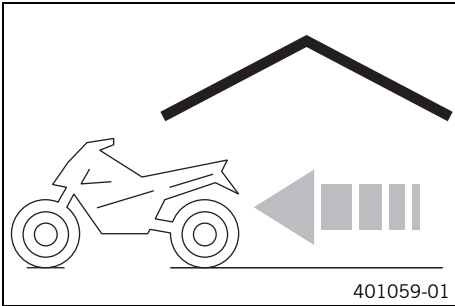











### (All XC models)

- Install the battery. (🔧 📖 p. 81)
- Remove the motorcycle from the lift stand. (📖 p. 42)
- Perform checks and maintenance measures when preparing for use. (📖 p. 25)
- Make a test ride.

| Faults   | Possible cause   | Action  |
|--|--|---|
| The engine cannot be cranked (electric starter)<br>(All XC models) | Operating error  | – Carry out the start procedure. (🔧 p. 25)  |
|  | Battery discharged   | – Recharge the battery. 🛠️ (🔧 p. 82)<br>– Check the charging voltage. 🛠️<br>– Check the closed current. 🛠️<br>– Check the alternator. 🛠️                                  |
|  | Main fuse blown  | – Change the main fuse. (🔧 p. 83)   |
|  | Starter relay faulty   | – Check the starter relay. 🛠️   |
|  | Starter motor faulty   | – Check the starter motor. 🛠️   |
| Engine turns but does not start                                    | Operating error  | – Carry out the start procedure. (🔧 p. 25)  |
|  | Motorcycle was out of use for a long time and there is old fuel in the float chamber   | – Empty the carburetor float chamber. 🛠️ (🔧 p. 96)  |
|  | Fuel feed interrupted  | – Check the fuel tank breather.<br>– Clean the fuel tap.<br>– Check/set the carburetor components.  |
|  | Spark plug oily or wet   | – Clean and dry the spark plug, or change it if necessary.  |
|  | Electrode distance (plug gap) of spark plug too wide                                   | – Adjust the plug gap.<br>Guideline<br>Spark plug electrode gap (All SX models)<br>0.60 mm (0.0236 in)<br>Spark plug electrode gap (All XC models)<br>0.60 mm (0.0236 in) |
|  | Fault in ignition system   | – Check the ignition system. 🛠️   |
|  | Kill switch cable in wiring harness frayed, kill switch defective                      | – Check the kill switch. 🛠️   |
|  | The connector or ignition coil is loose or oxidized                                    | – Clean the connector and treat it with contact spray.  |
| Engine has no idle   | Water in carburetor or jets blocked  | – Check/set the carburetor components.  |
|  | Idling jet blocked   | – Check/set the carburetor components.  |
|  | Adjusting screws on carburetor distorted   | – Carburetor – adjust the idle speed. 🛠️ (🔧 p. 91)  |
|  | Spark plug defective   | – Change the spark plug.  |
| Engine does not speed up   | Ignition system defective  | – Check the ignition coil. 🛠️<br>– Check the spark plug connector. 🛠️   |
|  | Carburetor running over because float needle dirty or worn                             | – Check/set the carburetor components.  |
|  | Loose carburetor jets  | – Check/set the carburetor components.  |
| Engine has too little power  | Fault in ignition system   | – Check the ignition system. 🛠️   |
|  | Fuel feed interrupted  | – Check the fuel tank breather.<br>– Clean the fuel tap.<br>– Check/set the carburetor components.  |
|  | Air filter very dirty  | – Clean the air filter and air filter box. 🛠️ (🔧 p. 54)   |
|  | Exhaust system leaky, deformed or too little glass fiber yarn filling in main silencer | – Check exhaust system for damage.<br>– Change glass fiber yarn filling in the main silencer. 🛠️ (🔧 p. 56)  |
|  | Fault in ignition system   | – Check the ignition system. 🛠️   |
| Diaphragm or reed valve housing damaged                            | – Check the diaphragm and reed valve housing.  |   |



| Faults  | Possible cause                                      | Action   |
|---|---|--|
| Engine stalls or is popping into the carburetor | Lack of fuel  | <p><b>(All SX models)</b></p> <ul style="list-style-type: none"> <li>– Turn handle ❶ of the fuel tap to the <b>ON</b> position. (Figure A00016-10  p. 15)</li> </ul> <p><b>(All XC models)</b></p> <ul style="list-style-type: none"> <li>– Turn handle ❶ of the fuel tap to the <b>ON</b> position. (Figure A00023-10  p. 15)</li> </ul> <p><b>(All XC models)</b></p> <ul style="list-style-type: none"> <li>– Turn handle ❶ of the fuel tap to the <b>RES</b> position. (Figure A00023-10  p. 15)</li> </ul> <ul style="list-style-type: none"> <li>– Refuel. ( p. 28)</li> </ul> |
|   | Engine takes in bad air                             | <ul style="list-style-type: none"> <li>– Check the intake flange and carburetor for tightness.</li> </ul>  |
|   | The connector or ignition coil is loose or oxidized | <ul style="list-style-type: none"> <li>– Clean the connector and treat it with contact spray.</li> </ul>   |
| Engine overheats                                | Too little coolant in cooling system                | <ul style="list-style-type: none"> <li>– Check the cooling system for leakage.</li> <li>– Check the coolant level. ( p. 85)</li> </ul>  |
|   | Too little air stream                               | <ul style="list-style-type: none"> <li>– Switch off engine when stationary.</li> </ul>   |
|   | Radiator fins very dirty                            | <ul style="list-style-type: none"> <li>– Clean the radiator fins.</li> </ul>   |
|   | Foam formation in cooling system                    | <ul style="list-style-type: none"> <li>– Drain the coolant.  ( p. 85)</li> <li>– Refill with coolant.  ( p. 86)</li> </ul>   |
|   | Damaged cylinder head or cylinder head gasket       | <ul style="list-style-type: none"> <li>– Check the cylinder head and cylinder head gasket.</li> </ul>  |
|   | Bent radiator hose                                  | <ul style="list-style-type: none"> <li>– Change the radiator hose. </li> </ul>  |
| White smoke emission (steam in exhaust gas)     | Damaged cylinder head or cylinder head gasket       | <ul style="list-style-type: none"> <li>– Check the cylinder head and cylinder head gasket.</li> </ul>  |
| Gear oil exits at the vent hose                 | Too much gear oil added                             | <ul style="list-style-type: none"> <li>– Check the gear oil level. ( p. 97)</li> </ul>  |
| Water in the gear oil                           | Damaged shaft seal ring or water pump               | <ul style="list-style-type: none"> <li>– Check the shaft seal ring and water pump.</li> </ul>  |

**21.1 Engine****21.1.1 All SX models**

|   |  |
|---|--|
| Design  | 1-cylinder 2-stroke engine, water-cooled, with reed intake and exhaust control                   |
| Displacement  | 249 cm <sup>3</sup> (15.19 cu in)  |
| Stroke  | 72 mm (2.83 in)  |
| Hole  | 66.4 mm (2.614 in)   |
| Exhaust valve, beginning of adjustment                      | 5,125 rpm  |
| Crankshaft bearing  | 1 grooved ball bearing/1 roller bearing  |
| Conrod bearing  | Needle bearing   |
| Piston pin bearing  | Needle bearing   |
| Piston  | Cast aluminum  |
| Piston rings  | 2 half keystone rings  |
| X distance (upper edge of piston to upper edge of cylinder) | 0... 0.10 mm (0... 0.0039 in)  |
| Z distance (height of control flap)                         | 49 mm (1.93 in)  |
| Primary transmission  | 26:73  |
| Clutch  | Multidisc clutch in oil bath/hydraulically activated   |
| Transmission  | 5-gear, claw shifted   |
| Transmission ratio  |  |
| First gear  | 14:28  |
| Second gear   | 16:26  |
| Third gear  | 18:24  |
| Fourth gear   | 21:24  |
| Fifth gear  | 22:21  |
| Ignition system   | Contactless controlled, fully electronic ignition with digital ignition adjustment, type Kokusan |
| Spark plug  | NGK BR 8 ECM   |
| Spark plug electrode gap                                    | 0.60 mm (0.0236 in)  |
| Starting aid  | Kick starter   |

**21.1.2 250 XC US**

|   |  |
|---|--|
| Design  | 1-cylinder 2-stroke engine, water-cooled, with reed intake and exhaust control |
| Displacement  | 249 cm <sup>3</sup> (15.19 cu in)  |
| Stroke  | 72 mm (2.83 in)  |
| Hole  | 66.4 mm (2.614 in)   |
| Exhaust valve, beginning of adjustment                      | 5,125 rpm  |
| Crankshaft bearing  | 1 grooved ball bearing/1 roller bearing  |
| Conrod bearing  | Needle bearing   |
| Piston pin bearing  | Needle bearing   |
| Piston  | Cast aluminum  |
| Piston rings  | 2 half keystone rings  |
| X distance (upper edge of piston to upper edge of cylinder) | 0... 0.10 mm (0... 0.0039 in)  |
| Z distance (height of control flap)                         | 49 mm (1.93 in)  |
| Primary transmission  | 26:73  |
| Clutch  | Multidisc clutch in oil bath/hydraulically activated                           |
| Transmission  | 6-gear, claw shifted   |
| Transmission ratio  |  |
| First gear  | 15:31  |
| Second gear   | 16:25  |
| Third gear  | 20:25  |
| Fourth gear   | 22:23  |

|                          |  |
|--------------------------|--|
| Fifth gear               | 25:22  |
| Sixth gear               | 26:20  |
| Ignition system          | Contactless controlled, fully electronic ignition with digital ignition adjustment, type Kokusan |
| Spark plug               | NGK BR 7 ES  |
| Spark plug electrode gap | 0.60 mm (0.0236 in)  |
| Starting aid             | Kick starter and electric starter  |

### 21.1.3 300 XC US

|   |  |
|---|--|
| Design  | 1-cylinder 2-stroke engine, water-cooled, with reed intake and exhaust control                   |
| Displacement  | 293.2 cm <sup>3</sup> (17.892 cu in)   |
| Stroke  | 72 mm (2.83 in)  |
| Hole  | 72 mm (2.83 in)  |
| Exhaust valve, beginning of adjustment                      | 5,150 rpm  |
| Crankshaft bearing  | 1 grooved ball bearing/1 roller bearing  |
| Conrod bearing  | Needle bearing   |
| Piston pin bearing  | Needle bearing   |
| Piston  | Cast aluminum  |
| Piston rings  | 2 rectangular rings  |
| X distance (upper edge of piston to upper edge of cylinder) | 0... 0.10 mm (0... 0.0039 in)  |
| Z distance (height of control flap)                         | 49.5 mm (1.949 in)   |
| Primary transmission  | 26:73  |
| Clutch  | Multidisc clutch in oil bath/hydraulically activated   |
| Transmission  | 6-gear, claw shifted   |
| Transmission ratio  |  |
| First gear  | 15:31  |
| Second gear   | 16:25  |
| Third gear  | 20:25  |
| Fourth gear   | 22:23  |
| Fifth gear  | 25:22  |
| Sixth gear  | 26:20  |
| Ignition system   | Contactless controlled, fully electronic ignition with digital ignition adjustment, type Kokusan |
| Spark plug  | NGK BR 7 ES  |
| Spark plug electrode gap                                    | 0.60 mm (0.0236 in)  |
| Starting aid  | Kick starter and electric starter  |

## 21.2 Engine tightening torques

### 21.2.1 All SX models

|  |                             |                   |                      |
|--|-----------------------------|-------------------|----------------------|
| Screw, inner membrane sheets           | <b>EJOT DELTA PT®</b> 35x25 | 1 Nm (0.7 lbf ft) | –                    |
| Screw, membrane support plate          | <b>EJOT DELTA PT®</b> 30x12 | 1 Nm (0.7 lbf ft) | –                    |
| Screw, outer membrane sheets           | <b>EJOT DELTA PT®</b> 30x6  | 1 Nm (0.7 lbf ft) | –                    |
| Screw, angle lever, exhaust control    | M5                          | 6 Nm (4.4 lbf ft) | <b>Loctite® 243™</b> |
| Screw, bearing retainer                | M5                          | 7 Nm (5.2 lbf ft) | <b>Loctite® 243™</b> |
| Screw, clutch spring retainer          | M5                          | 6 Nm (4.4 lbf ft) | –                    |
| Screw, crankshaft position sensor      | M5                          | 6 Nm (4.4 lbf ft) | <b>Loctite® 243™</b> |
| Screw, exhaust control bearing support | M5                          | 6 Nm (4.4 lbf ft) | <b>Loctite® 243™</b> |
| Screw, exhaust control cap             | M5                          | 5 Nm (3.7 lbf ft) | –                    |
| Screw, exhaust control cover           | M5                          | 4 Nm (3 lbf ft)   | <b>Loctite® 222™</b> |
| Screw, locking lever                   | M5                          | 6 Nm (4.4 lbf ft) | <b>Loctite® 243™</b> |

|   |           |                       |                |
|---|-----------|-----------------------|----------------|
| Screw, retaining bracket of exhaust control | M5        | 7 Nm (5.2 lbf ft)     | Loctite® 2701™ |
| Screw, stator                               | M5        | 6 Nm (4.4 lbf ft)     | Loctite® 243™  |
| Screw, water pump impeller                  | M5        | 6 Nm (4.4 lbf ft)     | Loctite® 243™  |
| Bleeder screw, cylinder head                | M6        | 10 Nm (7.4 lbf ft)    | –              |
| Outer clutch cover                          | M6        | 8 Nm (5.9 lbf ft)     | –              |
| Screw, alternator cover                     | M6        | 8 Nm (5.9 lbf ft)     | –              |
| Screw, clutch slave cylinder                | M6        | 10 Nm (7.4 lbf ft)    | –              |
| Screw, control flap, exhaust control        | M6        | 10 Nm (7.4 lbf ft)    | Loctite® 243™  |
| Screw, engine case                          | M6        | 10 Nm (7.4 lbf ft)    | –              |
| Screw, exhaust flange                       | M6        | 8 Nm (5.9 lbf ft)     | –              |
| Screw, gear oil level check                 | M6        | 10 Nm (7.4 lbf ft)    | –              |
| Screw, intake flange/reed valve housing     | M6        | 6 Nm (4.4 lbf ft)     | –              |
| Screw, intermediate clutch cover            | M6        | 10 Nm (7.4 lbf ft)    | –              |
| Screw, kick starter idler gear steel pin    | M6        | 10 Nm (7.4 lbf ft)    | Loctite® 243™  |
| Screw, kick starter stop plate              | M6        | 10 Nm (7.4 lbf ft)    | Loctite® 243™  |
| Screw, shift drum locating                  | M6        | 10 Nm (7.4 lbf ft)    | Loctite® 243™  |
| Screw, shift lever                          | M6        | 14 Nm (10.3 lbf ft)   | Loctite® 243™  |
| Screw, water pump cover                     | M6        | 10 Nm (7.4 lbf ft)    | –              |
| Screw, balancer shaft                       | M8        | 30 Nm (22.1 lbf ft)   | Loctite® 243™  |
| Screw, cylinder head                        | M8        | 27 Nm (19.9 lbf ft)   | –              |
| Screw, kick starter                         | M8        | 25 Nm (18.4 lbf ft)   | Loctite® 2701™ |
| Nut, cylinder base                          | M10       | 35 Nm (25.8 lbf ft)   | –              |
| Screw, drive chain engine sprocket          | M10       | 60 Nm (44.3 lbf ft)   | Loctite® 2701™ |
| Nut, rotor                                  | M12x1     | 60 Nm (44.3 lbf ft)   | –              |
| Gear oil drain plug with magnet             | M12x1.5   | 20 Nm (14.8 lbf ft)   | –              |
| Spark plug                                  | M14x1.25  | 25 Nm (18.4 lbf ft)   | –              |
| Nut, inner clutch hub                       | M18x1.5   | 100 Nm (73.8 lbf ft)  | Loctite® 648™  |
| Nut, primary gear                           | M18LHx1.5 | 150 Nm (110.6 lbf ft) | Loctite® 648™  |

## 21.2.2 All XC models

|   |                             |                    |                |
|---|-----------------------------|--------------------|----------------|
| Screw, inner membrane sheets                | <b>EJOT DELTA PT®</b> 35x25 | 1 Nm (0.7 lbf ft)  | –              |
| Screw, membrane support plate               | <b>EJOT DELTA PT®</b> 30x12 | 1 Nm (0.7 lbf ft)  | –              |
| Screw, outer membrane sheets                | <b>EJOT DELTA PT®</b> 30x6  | 1 Nm (0.7 lbf ft)  | –              |
| Screw, angle lever, exhaust control         | M5                          | 6 Nm (4.4 lbf ft)  | Loctite® 243™  |
| Screw, bearing retainer                     | M5                          | 7 Nm (5.2 lbf ft)  | Loctite® 243™  |
| Screw, clutch spring retainer               | M5                          | 6 Nm (4.4 lbf ft)  | –              |
| Screw, crankshaft position sensor           | M5                          | 6 Nm (4.4 lbf ft)  | Loctite® 243™  |
| Screw, exhaust control bearing support      | M5                          | 6 Nm (4.4 lbf ft)  | Loctite® 243™  |
| Screw, exhaust control cap                  | M5                          | 5 Nm (3.7 lbf ft)  | –              |
| Screw, exhaust control cover                | M5                          | 4 Nm (3 lbf ft)    | Loctite® 222™  |
| Screw, locking lever                        | M5                          | 6 Nm (4.4 lbf ft)  | Loctite® 243™  |
| Screw, retaining bracket of exhaust control | M5                          | 7 Nm (5.2 lbf ft)  | Loctite® 2701™ |
| Screw, water pump impeller                  | M5                          | 6 Nm (4.4 lbf ft)  | Loctite® 243™  |
| Bleeder screw, cylinder head                | M6                          | 10 Nm (7.4 lbf ft) | –              |
| Outer clutch cover                          | M6                          | 8 Nm (5.9 lbf ft)  | –              |
| Screw, alternator cover                     | M6                          | 8 Nm (5.9 lbf ft)  | –              |
| Screw, clutch slave cylinder                | M6                          | 10 Nm (7.4 lbf ft) | –              |
| Screw, control flap, exhaust control        | M6                          | 10 Nm (7.4 lbf ft) | Loctite® 243™  |
| Screw, engine case                          | M6                          | 10 Nm (7.4 lbf ft) | –              |
| Screw, exhaust flange                       | M6                          | 8 Nm (5.9 lbf ft)  | –              |

|  |           |                       |                       |
|--|-----------|-----------------------|-----------------------|
| Screw, gear oil level check              | M6        | 10 Nm (7.4 lbf ft)    | –                     |
| Screw, intake flange/reed valve housing  | M6        | 6 Nm (4.4 lbf ft)     | –                     |
| Screw, intermediate clutch cover         | M6        | 10 Nm (7.4 lbf ft)    | –                     |
| Screw, kick starter idler gear steel pin | M6        | 10 Nm (7.4 lbf ft)    | <b>Loctite® 243™</b>  |
| Screw, kick starter stop plate           | M6        | 10 Nm (7.4 lbf ft)    | <b>Loctite® 243™</b>  |
| Screw, shift drum locating               | M6        | 10 Nm (7.4 lbf ft)    | <b>Loctite® 243™</b>  |
| Screw, shift lever                       | M6        | 14 Nm (10.3 lbf ft)   | <b>Loctite® 243™</b>  |
| Screw, starter motor                     | M6        | 10 Nm (7.4 lbf ft)    | –                     |
| Screw, starter motor bearing bush        | M6        | 10 Nm (7.4 lbf ft)    | <b>Loctite® 243™</b>  |
| Screw, starter motor protection cap      | M6        | 8 Nm (5.9 lbf ft)     | –                     |
| Screw, stator                            | M6        | 10 Nm (7.4 lbf ft)    | <b>Loctite® 243™</b>  |
| Screw, water pump cover                  | M6        | 10 Nm (7.4 lbf ft)    | –                     |
| Screw, balancer shaft                    | M8        | 30 Nm (22.1 lbf ft)   | <b>Loctite® 243™</b>  |
| Screw, cylinder head                     | M8        | 27 Nm (19.9 lbf ft)   | –                     |
| Screw, kick starter                      | M8        | 25 Nm (18.4 lbf ft)   | <b>Loctite® 2701™</b> |
| Nut, cylinder base                       | M10       | 35 Nm (25.8 lbf ft)   | –                     |
| Screw, drive chain engine sprocket       | M10       | 60 Nm (44.3 lbf ft)   | <b>Loctite® 2701™</b> |
| Nut, rotor                               | M12x1     | 60 Nm (44.3 lbf ft)   | –                     |
| Gear oil drain plug with magnet          | M12x1.5   | 20 Nm (14.8 lbf ft)   | –                     |
| Spark plug                               | M14x1.25  | 25 Nm (18.4 lbf ft)   | –                     |
| Nut, inner clutch hub                    | M18x1.5   | 100 Nm (73.8 lbf ft)  | <b>Loctite® 648™</b>  |
| Nut, primary gear                        | M18LHx1.5 | 150 Nm (110.6 lbf ft) | <b>Loctite® 648™</b>  |

## 21.3 Carburetor

### 21.3.1 All SX models

|                                  |                              |
|----------------------------------|------------------------------|
| Carburetor type                  | MIKUNI TMX 38                |
| Carburetor identification number | TMX 38 84                    |
| Needle position                  | 3rd position from top        |
| Jet needle                       | 6BFY43-73 (6BFY44-73)        |
| Main jet                         | 440 (430, 450, 460)          |
| Idling jet                       | 42.5 (37.5 / 40 / 45 / 47.5) |
| Starting jet                     | 80                           |
| Needle jet                       | S-1                          |
| Idle air adjusting screw         |                              |
| Open                             | 1.5 turns                    |

### 21.3.2 Carburetor - basic setting for sandy surfaces (All SX models)

|                          |                       |
|--------------------------|-----------------------|
| Idle air adjusting screw |                       |
| Open                     | 1.5 turns             |
| Idling jet               | 45                    |
| Jet needle               | 6BFY44-73             |
| Needle position          | 3rd position from top |
| Main jet                 | 470                   |



#### Info

If the engine is not running smoothly, use a smaller main jet.

## 21.3.3 Carburetor tuning (All SX models)

| MIKUNI TMX 38                                    |                               |                                  |                                  |   |                                  |                                  |                                  |
|--|-------------------------------|----------------------------------|----------------------------------|---|----------------------------------|----------------------------------|----------------------------------|
| M/FT ASL<br>↓                                    | TEMP<br>→                     | -20°C ... -7°C                   | -6°C ... 5°C                     | 6°C ... 15°C  | 16°C ... 24°C                    | 25°C ... 36°C                    | 37°C ... 49°C                    |
|  |                               | -2°F ... 20°F                    | 19°F ... 41°F                    | 42°F ... 60°F   | 61°F ... 78°F                    | 79°F ... 98°F                    | 99°F ... 120°F                   |
| 3.000 m<br>10,000 ft<br>↑<br>2.301 m<br>7,501 ft | ASO<br>IJ<br>NDL<br>POS<br>MJ | 1,5<br>40<br>43-73<br>3<br>440   | 2<br>37,5<br>43-73<br>3<br>430   | 1,5<br>37,5<br>44-73<br>2<br>430                                    | 2<br>37,5<br>44-73<br>2<br>420   | 2<br>35<br>44-73<br>2<br>420     |                                  |
| 2.300 m<br>7,500 ft<br>↑<br>1.501 m<br>5,001 ft  | ASO<br>IJ<br>NDL<br>POS<br>MJ | 1,5<br>42,5<br>43-73<br>3<br>440 | 1,5<br>40<br>43-73<br>3<br>440   | 2<br>37,5<br>43-73<br>3<br>430                                      | 1,5<br>37,5<br>44-73<br>2<br>430 | 2<br>37,5<br>44-73<br>2<br>420   | 2<br>35<br>44-73<br>2<br>420     |
| 1.500 m<br>5,000 ft<br>↑<br>751 m<br>2,501 ft    | ASO<br>IJ<br>NDL<br>POS<br>MJ | 1,5<br>42,5<br>44-73<br>3<br>450 | 1,5<br>42,5<br>43-73<br>3<br>440 | 1,5<br>40<br>43-73<br>3<br>440                                      | 2<br>37,5<br>43-73<br>3<br>430   | 1,5<br>37,5<br>44-73<br>2<br>430 | 2<br>37,5<br>44-73<br>2<br>420   |
| 750 m<br>2,500 ft<br>↑<br>301 m<br>1,001 ft      | ASO<br>IJ<br>NDL<br>POS<br>MJ | 1,5<br>45<br>44-73<br>3<br>460   | 1,5<br>42,5<br>44-73<br>3<br>450 | <b>1,5</b><br><b>42,5</b><br><b>43-73</b><br><b>3</b><br><b>440</b> | 1,5<br>40<br>43-73<br>3<br>440   | 2<br>37,5<br>43-73<br>3<br>430   | 1,5<br>37,5<br>44-73<br>2<br>430 |
| 300 m<br>1,000 ft<br>↑<br>0 m<br>0 ft            | ASO<br>IJ<br>NDL<br>POS<br>MJ | 1,5<br>47,5<br>44-73<br>3<br>470 | 1,5<br>45<br>44-73<br>3<br>460   | 1,5<br>42,5<br>44-73<br>3<br>450                                    | 1,5<br>42,5<br>43-73<br>3<br>440 | 1,5<br>40<br>43-73<br>3<br>440   | 2<br>37,5<br>43-73<br>3<br>430   |

402893-01

|          |                               |
|----------|-------------------------------|
| M/FT ASL | Sea level                     |
| TEMP     | Temperature                   |
| ASO      | Idle air adjusting screw open |
| IJ       | Idling jet                    |
| NDL      | Needle                        |
| POS      | Needle position from top      |
| MJ       | Main jet                      |



### Info

Do not use on sandy terrain.

## 21.3.4 250 XC US

|                                  |                       |
|----------------------------------|-----------------------|
| Carburetor type                  | MIKUNI TMX 38         |
| Carburetor identification number | TMX 38 85             |
| Needle position                  | 2nd position from top |
| Jet needle                       | 6BFY43-75 (6BFY42-75) |
| Main jet                         | 470 (450, 460, 480)   |
| Idling jet                       | 35 (32.5/37.5)        |
| Starting jet                     | 80                    |
| Needle jet                       | S-4                   |
| Idle air adjusting screw         |                       |
| Open                             | 2 turns               |

## 21.3.5 Carburetor tuning (250 XC US)

| MIKUNI TMX 38                                    |                               |                                  |                                  |                                  |  |                                  |                                  |
|--|-------------------------------|----------------------------------|----------------------------------|----------------------------------|--|----------------------------------|----------------------------------|
| M/FT ASL<br>↓                                    | TEMP<br>→                     | -20°C ... -7°C                   | -6°C ... 5°C                     | 6°C ... 15°C                     | 16°C ... 24°C  | 25°C ... 36°C                    | 37°C ... 49°C                    |
|  |                               | -2°F ... 20°F                    | 19°F ... 41°F                    | 42°F ... 60°F                    | 61°F ... 78°F  | 79°F ... 98°F                    | 99°F ... 120°F                   |
| 3.000 m<br>10,000 ft<br>↑<br>2.301 m<br>7,501 ft | ASO<br>IJ<br>NDL<br>POS<br>MJ | 2<br>35<br>43-75<br>2<br>460     | 1,5<br>32,5<br>43-75<br>2<br>450 | 2<br>32,5<br>43-75<br>2<br>440   | 2,5<br>32,5<br>43-75<br>2<br>430                         | 2<br>32,5<br>42-75<br>2<br>430   |                                  |
| 2.300 m<br>7,500 ft<br>↑<br>1.501 m<br>5,001 ft  | ASO<br>IJ<br>NDL<br>POS<br>MJ | 1,5<br>35<br>43-75<br>2<br>470   | 2<br>35<br>43-75<br>2<br>460     | 1,5<br>32,5<br>43-75<br>2<br>450 | 2<br>32,5<br>43-75<br>2<br>450                           | 2,5<br>32,5<br>43-75<br>2<br>440 | 2<br>32,5<br>42-75<br>2<br>430   |
| 1.500 m<br>5,000 ft<br>↑<br>751 m<br>2,501 ft    | ASO<br>IJ<br>NDL<br>POS<br>MJ | 1,5<br>37,5<br>43-75<br>2<br>470 | 1,5<br>35<br>43-75<br>2<br>470   | 2<br>35<br>43-75<br>2<br>470     | 1,5<br>32,5<br>43-75<br>2<br>460                         | 2<br>32,5<br>43-75<br>2<br>450   | 2,5<br>32,5<br>43-75<br>2<br>440 |
| 750 m<br>2,500 ft<br>↑<br>301 m<br>1,001 ft      | ASO<br>IJ<br>NDL<br>POS<br>MJ | 2<br>37,5<br>42-75<br>3<br>470   | 1,5<br>37,5<br>43-75<br>2<br>470 | 1,5<br>35<br>43-75<br>2<br>470   | <b>2</b><br><b>35</b><br>43-75<br><b>2</b><br><b>470</b> | 1,5<br>32,5<br>43-75<br>2<br>460 | 2<br>32,5<br>43-75<br>2<br>450   |
| 300 m<br>1,000 ft<br>↑<br>0 m<br>0 ft            | ASO<br>IJ<br>NDL<br>POS<br>MJ | 2<br>37,5<br>42-75<br>3<br>470   | 1,5<br>37,5<br>43-75<br>2<br>470 | 1,5<br>35<br>43-75<br>2<br>470   | 2<br>35<br>43-75<br>2<br>470                             | 1,5<br>32,5<br>43-75<br>2<br>460 | 2<br>32,5<br>43-75<br>2<br>450   |

402894-01

|          |                               |
|----------|-------------------------------|
| M/FT ASL | Sea level                     |
| TEMP     | Temperature                   |
| ASO      | Idle air adjusting screw open |
| IJ       | Idling jet                    |



|     |                          |
|-----|--------------------------|
| NDL | Needle                   |
| POS | Needle position from top |
| MJ  | Main jet                 |

---

**i** **Info**  
Do not use on sandy terrain.

---

## 21.3.6 300 XC US

|                                  |                       |
|----------------------------------|-----------------------|
| Carburetor type                  | MIKUNI TMX 38         |
| Carburetor identification number | TMX 38 80             |
| Needle position                  | 2nd position from top |
| Jet needle                       | 6BFY43-75 (6BFY42-75) |
| Main jet                         | 450 (430, 440, 460)   |
| Idling jet                       | 25 (22.5/27.5)        |
| Starting jet                     | 80                    |
| Needle jet                       | S-4                   |
| Idle air adjusting screw         |                       |
| Open                             | 1.5 turns             |

## 21.3.7 Carburetor tuning (300 XC US) ↗

| MIKUNI TMX 38                                    |                               |                                |                                |                                |   |                                |                                |
|--|-------------------------------|--------------------------------|--------------------------------|--------------------------------|---|--------------------------------|--------------------------------|
| M/FT ASL<br>↓                                    | TEMP<br>→                     | -20°C ... -7°C                 | -6°C ... 5°C                   | 6°C ... 15°C                   | 16°C ... 24°C   | 25°C ... 36°C                  | 37°C ... 49°C                  |
|  |                               | -2°F ... 20°F                  | 19°F ... 41°F                  | 42°F ... 60°F                  | 61°F ... 78°F   | 79°F ... 98°F                  | 99°F ... 120°F                 |
| 3.000 m<br>10,000 ft<br>↑<br>2.301 m<br>7,501 ft | ASO<br>IJ<br>NDL<br>POS<br>MJ | 2<br>25<br>43-75<br>2<br>440   | 2,5<br>25<br>43-75<br>2<br>430 | 1,5<br>25<br>42-75<br>2<br>430 | 2<br>25<br>42-75<br>2<br>430                                      | 2<br>25<br>42-75<br>2<br>420   |                                |
| 2.300 m<br>7,500 ft<br>↑<br>1.501 m<br>5,001 ft  | ASO<br>IJ<br>NDL<br>POS<br>MJ | 2<br>25<br>42-75<br>3<br>440   | 2<br>25<br>43-75<br>2<br>440   | 2,5<br>25<br>43-75<br>2<br>430 | 1,5<br>25<br>42-75<br>2<br>440                                    | 2<br>25<br>42-75<br>2<br>430   | 2<br>25<br>42-75<br>2<br>420   |
| 1.500 m<br>5,000 ft<br>↑<br>751 m<br>2,501 ft    | ASO<br>IJ<br>NDL<br>POS<br>MJ | 2<br>25<br>42-75<br>3<br>450   | 2<br>27,5<br>43-75<br>2<br>450 | 2<br>25<br>43-75<br>2<br>440   | 2,5<br>25<br>43-75<br>2<br>440                                    | 1,5<br>25<br>42-75<br>2<br>440 | 2<br>25<br>42-75<br>2<br>430   |
| 750 m<br>2,500 ft<br>↑<br>301 m<br>1,001 ft      | ASO<br>IJ<br>NDL<br>POS<br>MJ | 2<br>27,5<br>42-75<br>3<br>470 | 2<br>25<br>42-75<br>3<br>460   | 2<br>27,5<br>43-75<br>2<br>450 | <b>1,5</b><br><b>25</b><br><b>43-75</b><br><b>2</b><br><b>450</b> | 2,5<br>25<br>43-75<br>2<br>440 | 1,5<br>25<br>42-75<br>2<br>440 |
| 300 m<br>1,000 ft<br>↑<br>0 m<br>0 ft            | ASO<br>IJ<br>NDL<br>POS<br>MJ | 2<br>27,5<br>42-75<br>3<br>470 | 2<br>25<br>42-75<br>3<br>460   | 2<br>27,5<br>43-75<br>2<br>460 | 1,5<br>25<br>43-75<br>2<br>460                                    | 2<br>25<br>43-75<br>2<br>450   | 2,5<br>25<br>43-75<br>2<br>440 |

402895-01

|          |                               |
|----------|-------------------------------|
| M/FT ASL | Sea level                     |
| TEMP     | Temperature                   |
| ASO      | Idle air adjusting screw open |
| IJ       | Idling jet                    |

|     |                          |
|-----|--------------------------|
| NDL | Needle                   |
| POS | Needle position from top |
| MJ  | Main jet                 |

**Info**

Do not use on sandy terrain.

## 21.4 Capacities

### 21.4.1 Gear oil

|          |                   |                                |
|----------|-------------------|--------------------------------|
| Gear oil | 0.80 l (0.85 qt.) | Engine oil (15W/50) (📖 p. 119) |
|----------|-------------------|--------------------------------|

### 21.4.2 Coolant

|         |                 |                    |
|---------|-----------------|--------------------|
| Coolant | 1.2 l (1.3 qt.) | Coolant (📖 p. 119) |
|---------|-----------------|--------------------|

### 21.4.3 Fuel

|   |                   |   |
|---|-------------------|---|
| Total fuel tank capacity, approx. (All SX models) | 7 l (1.8 US gal)  | Super unleaded (95 octane) mixed with 2-stroke engine oil (1:60) (📖 p. 120) |
| Total fuel tank capacity, approx. (All XC models) | 10 l (2.6 US gal) | Super unleaded (95 octane) mixed with 2-stroke engine oil (1:60) (📖 p. 120) |
| Fuel reserve approx. (All XC models)              | 1.5 l (1.6 qt.)   |   |

## 21.5 Chassis

|  |   |
|--|---|
| Frame  | Central tube frame made of chrome molybdenum steel tubing |
| Fork   | <b>WP Performance Systems</b> Upside down <b>AER 48</b>   |
| Suspension travel                            |   |
| Front  | 310 mm (12.2 in)  |
| Rear   | 300 mm (11.81 in)   |
| Fork offset                                  | 22 mm (0.87 in)   |
| Shock absorber                               | <b>WP Performance Systems</b> 5018 DCC Link               |
| Brake system                                 | Disc brakes, brake calipers on floating bearings          |
| Brake discs - diameter                       |   |
| Front  | 260 mm (10.24 in)   |
| Rear   | 220 mm (8.66 in)  |
| Brake discs - wear limit                     |   |
| Front  | 2.5 mm (0.098 in)   |
| Rear   | 3.5 mm (0.138 in)   |
| Tire air pressure off road                   |   |
| Front  | 1.0 bar (15 psi)  |
| Rear   | 1.0 bar (15 psi)  |
| Secondary ratio (All SX models)              | 14:50   |
| Secondary ratio (All XC models)              | 13:50   |
| Chain  | 5/8 x 1/4"  |
| Rear sprockets available                     | 48, 50, 52  |
| Steering head angle                          | 63.9°   |
| Wheelbase                                    | 1,485±10 mm (58.46±0.39 in)                               |
| Seat height unloaded                         | 960 mm (37.8 in)  |
| Ground clearance unloaded (All SX models)    | 375 mm (14.76 in)   |
| Ground clearance unloaded (All XC models)    | 370 mm (14.57 in)   |
| Weight without fuel, approx. (All SX models) | 95.4 kg (210.3 lb.)                                       |
| Weight without fuel, approx. (All XC models) | 98.4 kg (216.9 lb.)                                       |

|                                     |                  |
|-------------------------------------|------------------|
| Maximum permissible front axle load | 145 kg (320 lb.) |
| Maximum permissible rear axle load  | 190 kg (419 lb.) |
| Maximum permissible overall weight  | 335 kg (739 lb.) |

## 21.6 Electrical system

|                         |             |  |
|-------------------------|-------------|--|
| Battery (All XC models) | HJTZ5S-FP   | Lithium-ion battery<br>Battery voltage: 12 V<br>Nominal capacity: 2.0 Ah<br>Maintenance-free |
| Fuse (All XC models)    | 58011109110 | 10 A   |

## 21.7 Tires

| Validity        | Front tires                                     | Rear tires                                       |
|-----------------|---|--|
| (All SX models) | <b>80/100 - 21 51M TT</b><br>Dunlop GEOMAX MX3S | <b>110/90 - 19 62M TT</b><br>Dunlop GEOMAX MX3S  |
| (All XC models) | <b>90/90 - 21 54M TT</b><br>Dunlop GEOMAX AT81F | <b>110/100 - 18 64M TT</b><br>Dunlop GEOMAX AT81 |

The tires specified represent one of the possible series production tires. Additional information is available in the Service section under:  
<http://www.ktm.com>

## 21.8 Fork

### 21.8.1 250 SX EU

|                                       |   |   |
|---------------------------------------|---|---|
| Fork article number                   | 34.18.8R.03   |   |
| Fork                                  | <b>WP Performance Systems</b> Upside down <b>AER 48</b>               |   |
| Compression damping                   |   |   |
| Comfort                               | 17 clicks   |   |
| Standard                              | 12 clicks   |   |
| Sport                                 | 7 clicks  |   |
| Rebound damping                       |   |   |
| Comfort                               | 17 clicks   |   |
| Standard                              | 12 clicks   |   |
| Sport                                 | 7 clicks  |   |
| Air pressure                          | 10.3 bar (149 psi)  |   |
| Fork length                           | 950 mm (37.4 in)  |   |
| Oil capacity external mechanism left  | 200 $\pm$ $\frac{40}{20}$ ml (6.76 $\pm$ $\frac{1.35}{0.35}$ fl. oz.) | Fork oil (SAE 4) (48601166S1) (📖 p. 120)      |
| Oil capacity external mechanism right | 200 $\pm$ $\frac{40}{20}$ ml (6.76 $\pm$ $\frac{1.35}{0.35}$ fl. oz.) | Fork oil (SAE 4) (48601166S1) (📖 p. 120)      |
| Grease capacity, left cartridge       | 11 ml (0.37 fl. oz.)  | Multi-purpose grease (00062010051) (📖 p. 121) |
| Oil capacity, right cartridge         | 380 ml (12.85 fl. oz.)  | Fork oil (SAE 4) (48601166S1) (📖 p. 120)      |

### 21.8.2 250 SX US

|                     |   |  |
|---------------------|---|--|
| Fork article number | 34.18.8R.53   |  |
| Fork                | <b>WP Performance Systems</b> Upside down <b>AER 48</b> |  |
| Compression damping |   |  |
| Comfort             | 17 clicks   |  |
| Standard            | 12 clicks   |  |
| Sport               | 7 clicks  |  |
| Rebound damping     |   |  |
| Comfort             | 17 clicks   |  |
| Standard            | 12 clicks   |  |

|                                       |   |   |
|---------------------------------------|---|---|
| Sport                                 | 7 clicks  |   |
| Air pressure                          | 10.5 bar (152 psi)  |   |
| Fork length                           | 950 mm (37.4 in)  |   |
| Oil capacity external mechanism left  | 200 $\pm$ <sup>40</sup> / <sub>20</sub> ml (6.76 $\pm$ <sup>1.35</sup> / <sub>0.38</sub> fl. oz.) | Fork oil (SAE 4) (48601166S1) (📖 p. 120)      |
| Oil capacity external mechanism right | 200 $\pm$ <sup>40</sup> / <sub>20</sub> ml (6.76 $\pm$ <sup>1.35</sup> / <sub>0.38</sub> fl. oz.) | Fork oil (SAE 4) (48601166S1) (📖 p. 120)      |
| Grease capacity, left cartridge       | 11 ml (0.37 fl. oz.)  | Multi-purpose grease (00062010051) (📖 p. 121) |
| Oil capacity, right cartridge         | 380 ml (12.85 fl. oz.)  | Fork oil (SAE 4) (48601166S1) (📖 p. 120)      |

### 21.8.3 All XC models

|                     |   |  |
|---------------------|---|--|
| Fork article number | 34.18.8R.73   |  |
| Fork                | <b>WP Performance Systems</b> Upside down <b>AER 48</b> |  |
| Compression damping |   |  |
| Comfort             | 17 clicks   |  |
| Standard            | 12 clicks   |  |
| Sport               | 7 clicks  |  |
| Rebound damping     |   |  |
| Comfort             | 17 clicks   |  |
| Standard            | 12 clicks   |  |
| Sport               | 7 clicks  |  |
| Air pressure        | 9.4 bar (136 psi)                                       |  |
| Fork length         | 950 mm (37.4 in)  |  |

|                                       |   |   |
|---------------------------------------|---|---|
| Oil capacity external mechanism left  | 200 $\pm$ <sup>40</sup> / <sub>20</sub> ml (6.76 $\pm$ <sup>1.35</sup> / <sub>0.38</sub> fl. oz.) | Fork oil (SAE 4) (48601166S1) (📖 p. 120)      |
| Oil capacity external mechanism right | 200 $\pm$ <sup>40</sup> / <sub>20</sub> ml (6.76 $\pm$ <sup>1.35</sup> / <sub>0.38</sub> fl. oz.) | Fork oil (SAE 4) (48601166S1) (📖 p. 120)      |
| Grease capacity, left cartridge       | 11 ml (0.37 fl. oz.)  | Multi-purpose grease (00062010051) (📖 p. 121) |
| Oil capacity, right cartridge         | 380 ml (12.85 fl. oz.)  | Fork oil (SAE 4) (48601166S1) (📖 p. 120)      |

## 21.9 Shock absorber

### 21.9.1 250 SX EU

|   |   |  |
|---|---|--|
| Shock absorber article number                 | 18.18.7R.03                                 |  |
| Shock absorber                                | <b>WP Performance Systems</b> 5018 DCC Link |  |
| Compression damping, low-speed                |   |  |
| Comfort                                       | 17 clicks                                   |  |
| Standard                                      | 15 clicks                                   |  |
| Sport   | 13 clicks                                   |  |
| Compression damping, high-speed               |   |  |
| Comfort                                       | 2 turns                                     |  |
| Standard                                      | 1.5 turns                                   |  |
| Sport   | 1 turn                                      |  |
| Rebound damping                               |   |  |
| Comfort                                       | 17 clicks                                   |  |
| Standard                                      | 15 clicks                                   |  |
| Sport   | 13 clicks                                   |  |
| Spring preload                                | 6 mm (0.24 in)                              |  |
| Spring rate                                   |   |  |
| Weight of rider: 65... 75 kg (143... 165 lb.) | 39 N/mm (223 lb/in)                         |  |
| Weight of rider: 75... 85 kg (165... 187 lb.) | 42 N/mm (240 lb/in)                         |  |
| Weight of rider: 85... 95 kg (187... 209 lb.) | 45 N/mm (257 lb/in)                         |  |

|                                 |                   |
|---------------------------------|-------------------|
| Spring length                   | 260 mm (10.24 in) |
| Gas pressure                    | 10 bar (145 psi)  |
| Static sag                      | 35 mm (1.38 in)   |
| Riding sag                      | 105 mm (4.13 in)  |
| Fitted length                   | 477 mm (18.78 in) |
| Shock absorber fluid (📖 p. 120) | SAE 2.5           |

## 21.9.2 250 SX US

|   |   |
|---|---|
| Shock absorber article number                 | 18.18.7R.53                                 |
| Shock absorber                                | <b>WP Performance Systems</b> 5018 DCC Link |
| Compression damping, low-speed                |   |
| Comfort                                       | 17 clicks                                   |
| Standard                                      | 15 clicks                                   |
| Sport   | 13 clicks                                   |
| Compression damping, high-speed               |   |
| Comfort                                       | 2.5 turns                                   |
| Standard                                      | 2 turns                                     |
| Sport   | 1.5 turns                                   |
| Rebound damping                               |   |
| Comfort                                       | 17 clicks                                   |
| Standard                                      | 15 clicks                                   |
| Sport   | 13 clicks                                   |
| Spring preload                                | 5 mm (0.2 in)                               |
| Spring rate                                   |   |
| Weight of rider: 65... 75 kg (143... 165 lb.) | 39 N/mm (223 lb/in)                         |
| Weight of rider: 75... 85 kg (165... 187 lb.) | 42 N/mm (240 lb/in)                         |
| Weight of rider: 85... 95 kg (187... 209 lb.) | 45 N/mm (257 lb/in)                         |
| Spring length                                 | 260 mm (10.24 in)                           |
| Gas pressure                                  | 10 bar (145 psi)                            |
| Static sag                                    | 35 mm (1.38 in)                             |
| Riding sag                                    | 105 mm (4.13 in)                            |
| Fitted length                                 | 477 mm (18.78 in)                           |
| Shock absorber fluid (📖 p. 120)               | SAE 2.5                                     |

## 21.9.3 All XC models

|   |   |
|---|---|
| Shock absorber article number                 | 18.18.7R.73                                 |
| Shock absorber                                | <b>WP Performance Systems</b> 5018 DCC Link |
| Compression damping, low-speed                |   |
| Comfort                                       | 17 clicks                                   |
| Standard                                      | 15 clicks                                   |
| Sport   | 13 clicks                                   |
| Compression damping, high-speed               |   |
| Comfort                                       | 2.5 turns                                   |
| Standard                                      | 2 turns                                     |
| Sport   | 1.5 turns                                   |
| Rebound damping                               |   |
| Comfort                                       | 17 clicks                                   |
| Standard                                      | 15 clicks                                   |
| Sport   | 13 clicks                                   |
| Spring preload                                | 8 mm (0.31 in)                              |
| Spring rate                                   |   |
| Weight of rider: 65... 75 kg (143... 165 lb.) | 39 N/mm (223 lb/in)                         |

|   |                     |
|---|---------------------|
| Weight of rider: 75... 85 kg (165... 187 lb.) | 42 N/mm (240 lb/in) |
| Weight of rider: 85... 95 kg (187... 209 lb.) | 45 N/mm (257 lb/in) |
| Spring length                                 | 260 mm (10.24 in)   |
| Gas pressure                                  | 10 bar (145 psi)    |
| Static sag                                    | 35 mm (1.38 in)     |
| Riding sag                                    | 105 mm (4.13 in)    |
| Fitted length                                 | 477 mm (18.78 in)   |
| Shock absorber fluid (📖 p. 120)               | SAE 2.5             |

### 21.10 Chassis tightening torques

|  |      |                      |                |
|--|------|----------------------|----------------|
| Screw, E-starter button                              | M3   | 1 Nm (0.7 lbf ft)    | –              |
| Screw, kill switch                                   | M3   | 1 Nm (0.7 lbf ft)    | –              |
| Screw, fixed grip                                    | M4   | 5 Nm (3.7 lbf ft)    | Loctite® 243™  |
| Screw, service hour counter                          | M4   | 1 Nm (0.7 lbf ft)    | –              |
| Spoke nipple, front wheel                            | M4.5 | 6 Nm (4.4 lbf ft)    | –              |
| Spoke nipple, rear wheel                             | M4.5 | 6 Nm (4.4 lbf ft)    | –              |
| Remaining nuts, chassis                              | M5   | 5 Nm (3.7 lbf ft)    | –              |
| Remaining screws, chassis                            | M5   | 5 Nm (3.7 lbf ft)    | –              |
| Screw, battery terminal (All XC models)              | M5   | 2.5 Nm (1.84 lbf ft) | –              |
| Screw, shock absorber adjusting ring                 | M5   | 5 Nm (3.7 lbf ft)    | –              |
| Screws on the main silencer                          | M5   | 7 Nm (5.2 lbf ft)    | –              |
| Nut, cable on starter motor (All XC models)          | M6   | 4 Nm (3 lbf ft)      | –              |
| Remaining nuts, chassis                              | M6   | 10 Nm (7.4 lbf ft)   | –              |
| Remaining screws, chassis                            | M6   | 10 Nm (7.4 lbf ft)   | –              |
| Screw, absorbing element on frame                    | M6   | 6 Nm (4.4 lbf ft)    | –              |
| Screw, absorbing element on manifold                 | M6   | 6 Nm (4.4 lbf ft)    | –              |
| Screw, ball joint of push rod on foot brake cylinder | M6   | 10 Nm (7.4 lbf ft)   | Loctite® 243™  |
| Screw, chain sliding guard                           | M6   | 6 Nm (4.4 lbf ft)    | Loctite® 243™  |
| Screw, front brake disc                              | M6   | 14 Nm (10.3 lbf ft)  | Loctite® 243™  |
| Screw, rear brake disc                               | M6   | 14 Nm (10.3 lbf ft)  | Loctite® 243™  |
| Screw, throttle grip                                 | M6   | 5 Nm (3.7 lbf ft)    | –              |
| Nut, foot brake lever stop                           | M8   | 20 Nm (14.8 lbf ft)  | –              |
| Nut, rear sprocket screw                             | M8   | 35 Nm (25.8 lbf ft)  | Loctite® 2701™ |
| Nut, rim lock  | M8   | 12 Nm (8.9 lbf ft)   | –              |
| Remaining nuts, chassis                              | M8   | 25 Nm (18.4 lbf ft)  | –              |
| Remaining screws, chassis                            | M8   | 25 Nm (18.4 lbf ft)  | –              |
| Screw, bottom triple clamp                           | M8   | 12 Nm (8.9 lbf ft)   | –              |
| Screw, chain sliding piece                           | M8   | 15 Nm (11.1 lbf ft)  | –              |
| Screw, engine brace                                  | M8   | 25 Nm (18.4 lbf ft)  | Loctite® 2701™ |
| Screw, fork stub                                     | M8   | 15 Nm (11.1 lbf ft)  | –              |
| Screw, front brake caliper                           | M8   | 25 Nm (18.4 lbf ft)  | Loctite® 243™  |
| Screw, handlebar clamp                               | M8   | 20 Nm (14.8 lbf ft)  | –              |
| Screw, side stand attachment (All XC models)         | M8   | 35 Nm (25.8 lbf ft)  | Loctite® 2701™ |
| Screw, subframe                                      | M8   | 35 Nm (25.8 lbf ft)  | Loctite® 2701™ |
| Screw, top steering stem                             | M8   | 20 Nm (14.8 lbf ft)  | Loctite® 243™  |
| Screw, top triple clamp                              | M8   | 17 Nm (12.5 lbf ft)  | –              |
| Engine bracket screw                                 | M10  | 60 Nm (44.3 lbf ft)  | –              |
| Remaining nuts, chassis                              | M10  | 45 Nm (33.2 lbf ft)  | –              |
| Remaining screws, chassis                            | M10  | 45 Nm (33.2 lbf ft)  | –              |
| Screw, bottom shock absorber                         | M10  | 60 Nm (44.3 lbf ft)  | Loctite® 2701™ |

|                                   |         |                      |                       |
|-----------------------------------|---------|----------------------|-----------------------|
| Screw, handlebar support          | M10     | 40 Nm (29.5 lbf ft)  | <b>Loctite® 243™</b>  |
| Screw, top shock absorber         | M10     | 60 Nm (44.3 lbf ft)  | <b>Loctite® 2701™</b> |
| Nut, frame on linkage lever       | M14x1.5 | 80 Nm (59 lbf ft)    | –                     |
| Nut, linkage lever on swingarm    | M14x1.5 | 80 Nm (59 lbf ft)    | –                     |
| Nut, linkage lever to angle lever | M14x1.5 | 80 Nm (59 lbf ft)    | –                     |
| Nut, swingarm pivot               | M16x1.5 | 100 Nm (73.8 lbf ft) | –                     |
| Screw, front wheel spindle        | M20x1.5 | 35 Nm (25.8 lbf ft)  | –                     |
| Screw, top steering head          | M20x1.5 | 12 Nm (8.9 lbf ft)   | –                     |
| Screw-in nozzles, cooling system  | M20x1.5 | 12 Nm (8.9 lbf ft)   | <b>Loctite® 243™</b>  |
| Nut, rear wheel spindle           | M25x1.5 | 80 Nm (59 lbf ft)    | –                     |



## Brake fluid DOT 4 / DOT 5.1

### Standard/classification

- DOT

### Guideline

- Use only brake fluid that complies with the specified standard (see specifications on the container) and that exhibits the corresponding properties.

### Recommended supplier

#### Castrol

- **REACT PERFORMANCE DOT 4**

#### Motorex®

- **Brake Fluid DOT 5.1**

## Coolant

### Guideline

- Only use high-grade, silicate-free coolant with corrosion inhibitor additive for aluminum motors. Low grade and unsuitable antifreeze causes corrosion, deposits and frothing.
- Do not use pure water as only coolant is able to meet the requirements needed in terms of corrosion protection and lubrication properties.
- Only use coolant that complies with the requirements stated (see specifications on the container) and that has the relevant properties.

|                                   |                 |
|-----------------------------------|-----------------|
| Antifreeze protection to at least | -25 °C (-13 °F) |
|-----------------------------------|-----------------|

The mixture ratio must be adjusted to the necessary antifreeze protection. Use distilled water if the coolant needs to be diluted.

The use of premixed coolant is recommended.

Observe the coolant manufacturer specifications for antifreeze protection, dilution and miscibility (compatibility) with other coolants.

### Recommended supplier

#### Motorex®

- **COOLANT M3.0**

## Engine oil (15W/50)

### Standard/classification

- JASO T903 MA (📖 p. 123)
- SAE (📖 p. 123) (15W/50)

### Guideline

- Use only engine oils that comply with the specified standards (see specifications on the container) and that possess the corresponding properties.

### Recommended supplier

#### Motorex®

- **Top Speed 4T**

## Engine oil, 2-stroke

### Standard/classification

- JASO FD (📖 p. 123)

### Guideline

- Only use high grade 2-stroke engine oil of a reputable brand.

|                 |
|-----------------|
| Fully synthetic |
|-----------------|

### Recommended supplier

#### Motorex®

- **Cross Power 2T**

## Fork oil (SAE 4) (48601166S1)

### Standard/classification

- SAE (📖 p. 123) (SAE 4)

### Guideline

- Use only oils that comply with the specified standards (see specifications on the container) and that exhibit the corresponding properties.

## Shock absorber fluid (SAE 2.5) (50180751S1)

### Standard/classification

- SAE (📖 p. 123) (SAE 2.5)

### Guideline

- Use only oils that comply with the specified standards (see specifications on the container) and that exhibit the corresponding properties.

## Super unleaded (ROZ 95/RON 95/PON 91)

### Standard/classification

- DIN EN 228 (ROZ 95/RON 95/PON 91)

### Guideline

- Only use unleaded super fuel that matches or is equivalent to the specified fuel grade.
- Fuel with an ethanol content of up to 10 % (E10 fuel) is safe to use.



### Info

Do **not** use fuel containing methanol (e. g. M15, M85, M100) or more than 10 % ethanol (e. g. E15, E25, E85, E100).

## Super unleaded (95 octane) mixed with 2-stroke engine oil (1:60)

### Standard/classification

- DIN EN 228
- JASO FD (📖 p. 123) (1:60)

### Mixture ratio

|      |   |
|------|---|
| 1:60 | Engine oil, 2-stroke (📖 p. 119)<br>Super unleaded (ROZ 95/RON 95/PON 91) (📖 p. 120) |
|------|---|

### Recommended supplier

#### Motorex®

- **Cross Power 2T**

## Air filter cleaner

Recommended supplier

Motorex®

- Racing Bio Dirt Remover

## Chain cleaner

Recommended supplier

Motorex®

- Chain Clean

## Fuel additive

Recommended supplier

Motorex®

- Fuel Stabilizer

## High viscosity grease

Recommended supplier

SKF®

- LGHB 2

## Long-life grease

Recommended supplier

Motorex®

- Bike Grease 2000

## Motorcycle cleaner

Recommended supplier

Motorex®

- Moto Clean

## Multi-purpose grease (00062010051)

Recommended supplier

Klüber Lubrication®

- CENTOPLEX 2 EP

## Off-road chain spray

Recommended supplier

Motorex®

- Chainlube Offroad

## Oil for foam air filter

Recommended supplier

Motorex®

- Racing Bio Liquid Power

## Preserving materials for paints, metal and rubber

Recommended supplier

Motorex®

- Moto Protect

## Special cleaner for glossy and matte paint finishes, metal and plastic surfaces

Recommended supplier

Motorex®

- Quick Cleaner

### Universal oil spray

Recommended supplier

Motorex®

– Joker 440 Synthetic

## JASO T903 MA

Different technical development directions required a separate specification for 4-stroke motorcycles – the **JASO T903 MA** standard. Earlier, engine oils from the automobile industry were used for 4-stroke motorcycles because there was no separate motorcycle specification.

Whereas long service intervals are demanded for automobile engines, the focus for motorcycle engines is on high performance at high engine speeds.

In most motorcycle engines, the transmission and the clutch are lubricated with the same oil.

The **JASO MA** standard meets these special requirements.

## SAE

The SAE viscosity classes were defined by the Society of Automotive Engineers and are used for classifying oils according to their viscosity. The viscosity describes only one property of oil and says nothing about quality.

## JASO FD

JASO FD is a classification for a 2-stroke engine oil that was specifically developed for the extreme demands of racing. Thanks to first rate synthetic esters and specially designed additives, superb combustion is achieved even under extreme operating conditions.

## 25 LIST OF ABBREVIATIONS

|          |                |
|----------|----------------|
| Art. no. | Article number |
| ca.      | circa          |
| cf.      | compare        |
| e.g.     | for example    |
| etc.     | et cetera      |
| i.a.     | inter alia     |
| no.      | number         |
| poss.    | possibly       |

|                              |         |
|------------------------------|---------|
| <b>A</b>                     |         |
| <b>Accessories</b>           | 9       |
| <b>Air filter</b>            |         |
| cleaning                     | 54      |
| installing                   | 55      |
| removing                     | 54      |
| <b>Air filter box</b>        |         |
| cleaning                     | 54      |
| sealing                      | 55      |
| <b>Air filter box cover</b>  |         |
| installing                   | 53      |
| removing                     | 53      |
| securing                     | 55      |
| <b>Air suspension AER 48</b> | 32      |
| <b>Antifreeze</b>            |         |
| checking                     | 84      |
| <b>Auxiliary substances</b>  | 9       |
| <b>B</b>                     |         |
| <b>Basic chassis setting</b> |         |
| checking with rider's weight | 32      |
| <b>Battery</b>               |         |
| installing                   | 81      |
| recharging                   | 82      |
| removing                     | 81      |
| <b>Brake discs</b>           |         |
| checking                     | 67      |
| <b>Brake fluid</b>           |         |
| front brake, adding          | 68      |
| rear brake, adding           | 73      |
| <b>Brake fluid level</b>     |         |
| front brake, checking        | 68      |
| rear brake, checking         | 72      |
| <b>Brake linings</b>         |         |
| front brake, checking        | 69      |
| of front brake, changing     | 69      |
| rear brake, changing         | 74      |
| rear brake, checking         | 73      |
| <b>C</b>                     |         |
| <b>Capacity</b>              |         |
| coolant                      | 113     |
| gear oil                     | 98, 113 |
| <b>Carburetor</b>            |         |
| float chamber, emptying      | 96      |
| idle                         | 91      |
| idle speed, adjusting        | 91      |
| <b>Carburetor setting</b>    | 89      |
| <b>Chain</b>                 |         |
| checking                     | 61      |
| cleaning                     | 60      |
| <b>Chain guide</b>           |         |
| checking                     | 61      |
| <b>Chain tension</b>         |         |
| adjusting                    | 61      |
| checking                     | 60      |

|                                       |       |
|---------------------------------------|-------|
| <b>Chassis number</b>                 | 12    |
| <b>Choke</b>                          | 16    |
| <b>Clutch</b>                         |       |
| fluid level, checking/correcting      | 65    |
| fluid, changing                       | 65    |
| <b>Clutch lever</b>                   | 13    |
| basic position, adjusting             | 64    |
| <b>Compression damping</b>            |       |
| fork, adjusting                       | 39    |
| <b>Coolant</b>                        |       |
| draining                              | 85    |
| refilling                             | 86    |
| <b>Coolant level</b>                  |       |
| checking                              | 84-85 |
| <b>Cooling system</b>                 | 84    |
| <b>Customer service</b>               | 9     |
| <b>D</b>                              |       |
| <b>Difficult operating conditions</b> |       |
| high temperatures                     | 23    |
| riding at low speeds                  | 23    |
| <b>Difficult riding conditions</b>    | 20    |
| dry sand                              | 21    |
| low temperature                       | 24    |
| muddy surfaces                        | 23    |
| snow                                  | 24    |
| wet sand                              | 22    |
| wet surfaces                          | 23    |
| <b>E</b>                              |       |
| <b>Electric starter button</b>        | 13    |
| <b>Engine</b>                         |       |
| running in                            | 20    |
| <b>Engine characteristic</b>          |       |
| auxiliary spring                      | 93    |
| auxiliary spring, setting             | 93    |
| <b>Engine number</b>                  | 12    |
| <b>Engine sprocket</b>                |       |
| checking                              | 61    |
| <b>Environment</b>                    | 7     |
| <b>F</b>                              |       |
| <b>Figures</b>                        | 9     |
| <b>Filler cap</b>                     |       |
| closing                               | 14    |
| opening                               | 14    |
| <b>Filling up</b>                     |       |
| fuel                                  | 28    |
| <b>Foot brake lever</b>               | 17    |
| basic position, adjusting             | 71    |
| free travel, checking                 | 71    |
| <b>Fork</b>                           |       |
| air pressure, adjusting               | 38    |
| article number                        | 12    |
| basic setting, checking               | 37    |
| <b>Fork legs</b>                      |       |
| bleeding                              | 43    |
| dust boots, cleaning                  | 43    |

|                                       |    |  |     |
|---------------------------------------|----|--|-----|
| installing                            | 44 | removing   | 56  |
| removing                              | 43 |  |     |
| <b>Fork protector</b>                 |    | <b>Misuse</b>  | 6   |
| installing                            | 45 |  |     |
| removing                              | 44 | <b>Motorcycle</b>                                      |     |
| <b>Frame</b>                          |    | cleaning   | 99  |
| checking                              | 63 | lift stand, raising with                               | 42  |
| <b>Front fender</b>                   |    | lift stand, removing from                              | 42  |
| installing                            | 49 |  |     |
| removing                              | 49 | <b>O</b>   |     |
| <b>Front wheel</b>                    |    | <b>Operating substances</b>                            | 9   |
| installing                            | 76 | <b>Owner's Manual</b>                                  | 8   |
| removing                              | 76 | <b>P</b>   |     |
| <b>Fuel tank</b>                      |    | <b>Plug-in stand</b>                                   | 17  |
| installing                            | 58 | <b>Preparing for use</b>                               |     |
| removing                              | 57 | advice on first use                                    | 19  |
| <b>Fuel tap</b>                       | 15 | after storage  | 101 |
| <b>Fuse</b>                           |    | checks and maintenance measures when preparing for use | 25  |
| main fuse, changing                   | 83 | <b>Protective clothing</b>                             | 7   |
| <b>G</b>                              |    | <b>R</b>   |     |
| <b>Gear oil</b>                       |    | <b>Rear sprocket</b>                                   |     |
| adding                                | 98 | checking   | 61  |
| changing                              | 97 | <b>Rear wheel</b>                                      |     |
| <b>Gear oil level</b>                 |    | installing   | 78  |
| checking                              | 97 | removing   | 77  |
| <b>H</b>                              |    | <b>Rebound damping</b>                                 |     |
| <b>Hand brake lever</b>               | 13 | fork, adjusting  | 39  |
| basic position, adjusting             | 67 | shock absorber, adjusting                              | 34  |
| free travel, checking                 | 67 | <b>Riding sag</b>                                      |     |
| <b>Handlebar position</b>             | 40 | adjusting  | 37  |
| adjusting                             | 40 | <b>Rubber grip</b>                                     |     |
| <b>High-speed compression damping</b> |    | checking   | 64  |
| shock absorber, adjusting             | 33 | <b>S</b>   |     |
| <b>I</b>                              |    | <b>Safe operation</b>                                  | 7   |
| <b>Ignition timing map</b>            |    | <b>Seat</b>  |     |
| changing                              | 92 | mounting   | 53  |
| plug-in connector                     | 92 | removing   | 52  |
| <b>Implied warranty</b>               | 9  | <b>Service</b>   | 9   |
| <b>Intended use</b>                   | 6  | <b>Service hour counter</b>                            | 18  |
| <b>K</b>                              |    | <b>Shift lever</b>                                     | 16  |
| <b>Kick starter</b>                   | 17 | basic position, adjusting                              | 93  |
| <b>Kill switch</b>                    | 13 | basic position, checking                               | 92  |
| <b>L</b>                              |    | <b>Shock absorber</b>                                  |     |
| <b>Lower triple clamp</b>             |    | article number   | 12  |
| installing                            | 46 | compression damping, general                           | 32  |
| removing                              | 45 | installing   | 51  |
| <b>Low-speed compression damping</b>  |    | removing   | 50  |
| shock absorber, adjusting             | 33 | riding sag, checking                                   | 36  |
| <b>M</b>                              |    | spring pretension, adjusting                           | 36  |
| <b>Main fuse</b>                      |    | static sag, checking                                   | 35  |
| changing                              | 83 | <b>Side stand</b>                                      | 17  |
| <b>Main silencer</b>                  |    | <b>Spare parts</b>                                     | 9   |
| glass fiber yarn filling, changing    | 56 | <b>Spoke tension</b>                                   |     |
| installing                            | 56 | checking   | 79  |
|                                       |    | <b>Start number plate</b>                              |     |
|                                       |    | installing   | 49  |
|                                       |    | removing   | 49  |
|                                       |    | <b>Starting</b>  | 25  |



|                                   |         |
|-----------------------------------|---------|
| <b>Steering head bearing</b>      |         |
| greasing                          | 48      |
| <b>Steering head bearing play</b> |         |
| adjusting                         | 48      |
| checking                          | 47      |
| <b>Storage</b>                    | 100     |
| <b>Swingarm</b>                   |         |
| checking                          | 63      |
| <b>T</b>                          |         |
| <b>Technical data</b>             |         |
| capacities                        | 113     |
| carburetor                        | 108     |
| chassis                           | 113     |
| chassis tightening torques        | 117     |
| electrical system                 | 114     |
| engine                            | 104     |
| engine tightening torques         | 105     |
| fork                              | 114     |
| shock absorber                    | 115     |
| tires                             | 114     |
| <b>Throttle cable play</b>        |         |
| adjusting                         | 88      |
| checking                          | 88      |
| <b>Throttle cable routing</b>     |         |
| checking                          | 63      |
| <b>Throttle grip</b>              | 13      |
| <b>Tire air pressure</b>          |         |
| checking                          | 79      |
| <b>Tire condition</b>             |         |
| checking                          | 79      |
| <b>Transport</b>                  | 28      |
| <b>Troubleshooting</b>            | 102-103 |
| <b>Type label</b>                 | 12      |
| <b>U</b>                          |         |
| <b>Use definition</b>             | 6       |
| <b>V</b>                          |         |
| <b>View of vehicle</b>            |         |
| front left                        | 10      |
| rear right                        | 11      |
| <b>W</b>                          |         |
| <b>Warranty</b>                   | 9       |
| <b>Work rules</b>                 | 7       |

**READY TO RACE**

>> [www.ktm.com](http://www.ktm.com)



3213637en

03/2017



**KTM**

**KTM Sportmotorcycle GmbH**  
5230 Mattighofen/Austria  
<http://www.ktm.com>



KTM Group Partner



REG. NO. 12 100 6061

Photo: Mitterbauer/KTM