

**350 EXC-F**  
**350 EXC-F Six Days**

Art. no. 3213898en



**KTM**



Perform the work described in these setup instructions before the vehicle is delivered to the customer.

Read the setup instructions in their entirety before beginning work.

These setup instructions were written to correspond to the latest state of this series. We reserve the right to make changes in the interest of technical advancement without at the same time updating this manual.

We shall not provide a description of general workshop methods. Likewise, safety rules that apply in a workshop are not specified here. It is assumed that the work will be performed by a fully trained mechanic.

All specifications are non-binding. KTM Sportmotorcycle GmbH specifically reserves the right to modify or delete technical specifications, prices, colors, forms, materials, services, designs, equipment, etc., without prior notice and without specifying reasons, to adapt these to local conditions, as well as to stop production of a particular model without prior notice. KTM accepts no liability for delivery options, deviations from illustrations and descriptions, misprints, and other errors. The models portrayed partly contain special equipment that does not belong to the regular scope of supply.

© 2018 KTM Sportmotorcycle GmbH, Mattighofen Austria

All rights reserved

Reproduction, even in part, as well as copying of all kinds, is permitted only with the express written permission of the copyright owner.



ISO 9001(12 100 6061)

According to the international quality management standard ISO 9001, KTM uses quality assurance processes that lead to the maximum possible quality of the products.

Issued by: TÜV Management Service

REG.NO. 12 100 6061

KTM Sportmotorcycle GmbH

Stallhofnerstraße 3

5230 Mattighofen, Austria

This document is valid for the following models:

350 EXC-F EU (F8203S9)

350 EXC-F AU (F8260S9)

350 EXC-F US (F8275S9)

350 EXC-F BR (F8240S9)

350 EXC-F Six Days EU (F8203S2)

350 EXC-F Six Days BR (F8240S2)



# 1 MEANS OF REPRESENTATION

## 1.1 Symbols used

The meaning of specific symbols is described below.



Indicates an expected reaction (e.g. of a work step or a function).



Indicates an unexpected reaction (e.g. of a work step or a function).



Indicates a page reference (more information is provided on the specified page).



Indicates information with more details or tips.



Indicates the result of a testing step.



Indicates a voltage measurement.



Indicates a current measurement.



Indicates a resistance measurement.



Indicates the end of an activity including potential rework.

## 1.2 Formats used

The typographical formats used in this document are explained below.

**Proprietary name**

Indicates a proprietary name.

**Name®**

Indicates a protected name.

**Brand™**

Indicates a brand available on the open market.

**Underlined terms**

Refer to technical details of the vehicle or indicate technical terms, which are explained in the glossary.

## 2.1 Transport mode

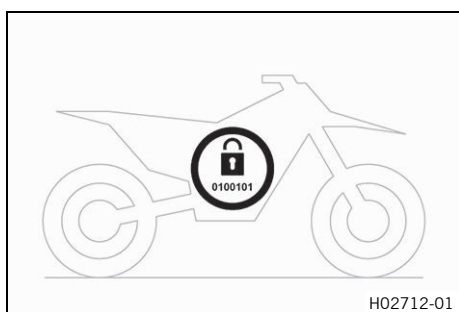

This vehicle was blocked for transport in the software. To operate the vehicle, the vehicle electronics must be enabled. This process is conducted during initial setup in KTM Dealer.net. Enabling ensures that the initial setup in KTM Dealer.net is documented.

Enabling can be performed either temporarily, e.g. for a test ride, or permanently for vehicle handover.



### Info

Make sure that the vehicle is permanently enabled before handing it over to the customer.

## 2.2 Unpacking and setting up the vehicle

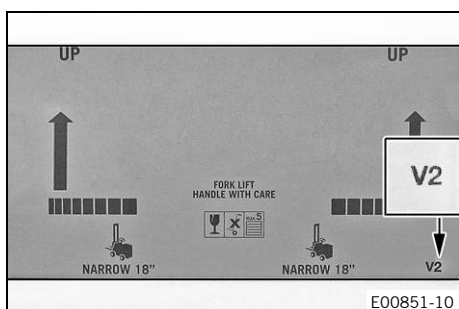

### Condition

#### Packaging V2

- Remove the box and the plastic packaging.



### Info

To avoid damaging the motorcycle during the setup, leave the protective film on the vehicle until you have finished.

- Remove the separate enclosure and unpack it. Check that the scope of supply is complete on the basis of the enclosed packing list.
- Have a lift stand available.

Lift stand (78129955100)

- Carefully loosen and remove the tension belt of the footrest mount.



### Info

An assistant prevents the motorcycle from falling over.

- Together with an assistant, take the vehicle off the palette.
- Position the vehicle on a lift stand.
- Check the vehicle for transport damage.

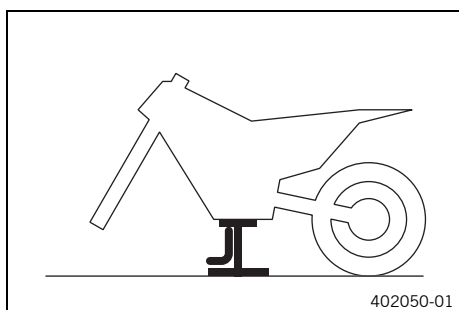

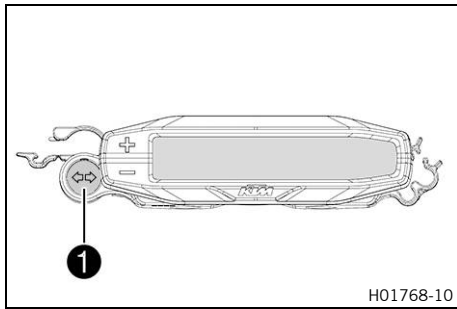

- Position turn signal indicator lamp **1** in the speedometer bracket.
- Remove the headlight mask with the headlight. (📖 p. 20)

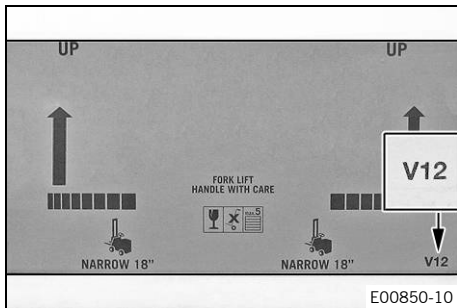

### Condition

#### Packaging V12

- Remove the box and the plastic packaging.



#### Info

An assistant prevents the motorcycle from falling over. To avoid damaging the motorcycle during the setup, leave the protective film on the vehicle until you have finished.

- Remove and unpack the separate enclosure and attachments. Check that the scope of supply is complete on the basis of the enclosed packing list.
- Remove the two cable ties on the triple clamp.
- Have a lift stand available.

Lift stand (78129955100)

- Together with an assistant, take the vehicle off the palette.
- Position the vehicle on a lift stand.
- Check the vehicle and attachments for transport damage.
- Install the shock absorber. (📖 p. 23)

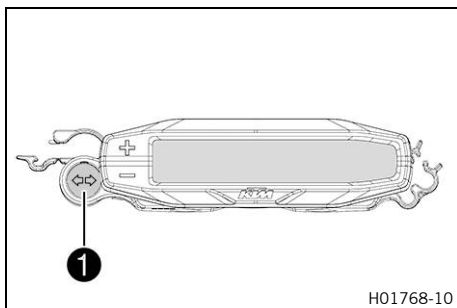
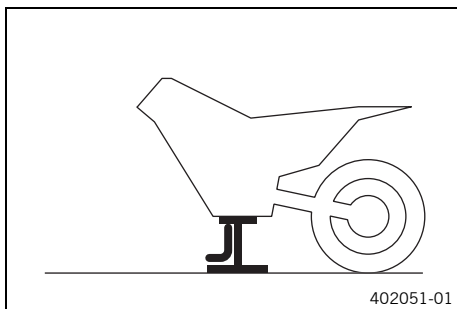

- Position turn signal indicator lamp **1** in the speedometer bracket.

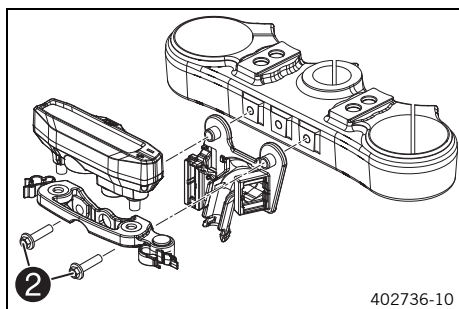

402736-10

- Mount the connector retainer and speedometer on the upper triple clamp.
- Mount and tighten screws ②.

Guideline

Remaining screws, chassis	M6	10 Nm (7.4 lbf ft)
---------------------------	----	--------------------

- Route the clutch line with the clutch master cylinder toward the front between the upper and lower triple clamps.
- Install the fork legs. (📖 p. 24)

**(EXC-F EU/AU/US/BR)**

- Remove screws ③ and take off handlebar supports.
- Move the handlebar supports to the desired position and mount and tighten screws ③.

Guideline

Screw, handlebar holder	M10	40 Nm (29.5 lbf ft) <b>Loctite®243™</b>
-------------------------	-----	--------------------------------------------



**Info**

Position the left and right handlebar supports evenly.

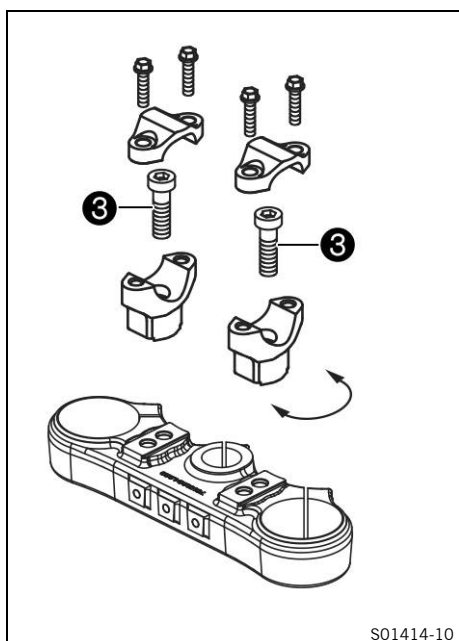

S01414-10



E00483-01



**Warning**

**Danger of accidents** A repaired handlebar poses a safety risk.

If the handlebar is bent or straightened, the material becomes fatigued. The handlebar may break as a result.

- Change the handlebar if the handlebar is damaged or bent.

- Position the handlebar.



**Info**

Make sure the cables and wiring are positioned correctly.

- Position the handlebar clamps. Mount and tighten the screws evenly.

Guideline

Screw, handlebar clamp	M8	20 Nm (14.8 lbf ft)
------------------------	----	------------------------

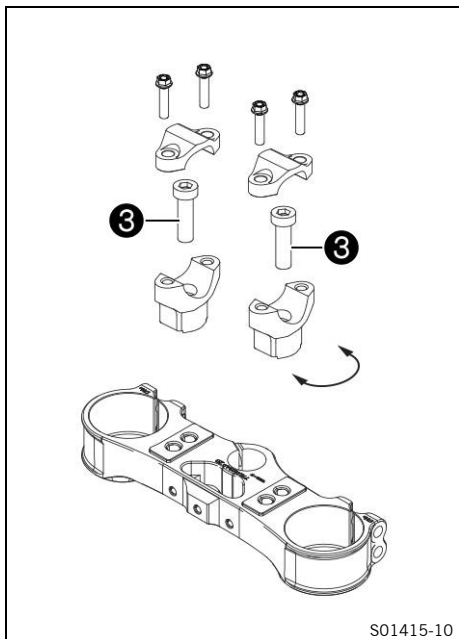

S01415-10



S01413-01



**Info**

The markings on the handlebar should be at the center of the handlebar clamps. Keep the gap widths equal when tightening.

**(All Six Days models)**

- Remove screws ③ and take off handlebar supports.
- Move the handlebar supports to the desired position and mount and tighten screws ③.

Guideline

Screw, handlebar holder	M10	40 Nm (29.5 lbf ft) <b>Loctite®243™</b>
-------------------------	-----	--------------------------------------------



**Info**

Position the left and right handlebar supports evenly.



**Warning**

**Danger of accidents** A repaired handlebar poses a safety risk.

If the handlebar is bent or straightened, the material becomes fatigued. The handlebar may break as a result.

- Change the handlebar if the handlebar is damaged or bent.

- Position the handlebar.



**Info**

Make sure the cables and wiring are positioned correctly.

- Position the handlebar clamps. Mount and tighten the screws evenly.

Guideline

Screw, handlebar clamp	M8	20 Nm (14.8 lbf ft)
------------------------	----	------------------------



**Info**

The markings on the handlebar should be at the center of the handlebar clamps. Keep the gap widths equal when tightening.





**(EXC-F EU/AU/BR, All Six Days models)**

- Position the controls on the right half of the handlebar.



**(EXC-F US)**

- Position the controls on the right half of the handlebar.

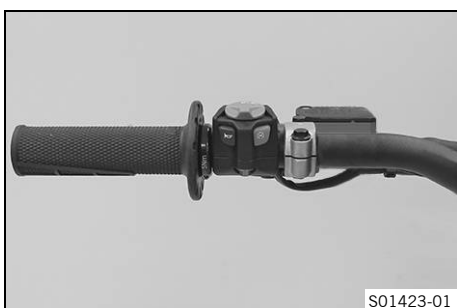

**(EXC-F EU/AU/BR, All Six Days models)**

- Position the controls on the left half of the handlebar.



**(All Six Days models)**



**Warning**

**Voiding of the government approval for road use and the insurance coverage** If the combination switch is installed, the vehicle's approval for road use is invalidated.

- Only operate the vehicle in closed-off areas remote from public road traffic if the combination switch is installed.

- (Optional) Mount the left side combination switch.



**Info**

The figure shows a possible installation position of the left side combination switch.

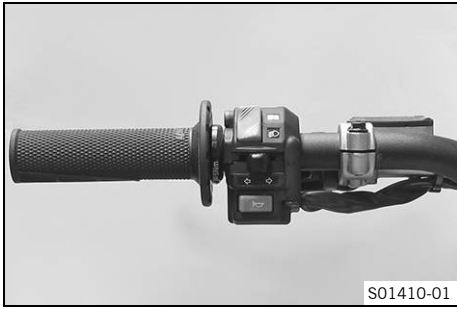

**(EXC-F US)**

- Position the controls on the left half of the handlebar.

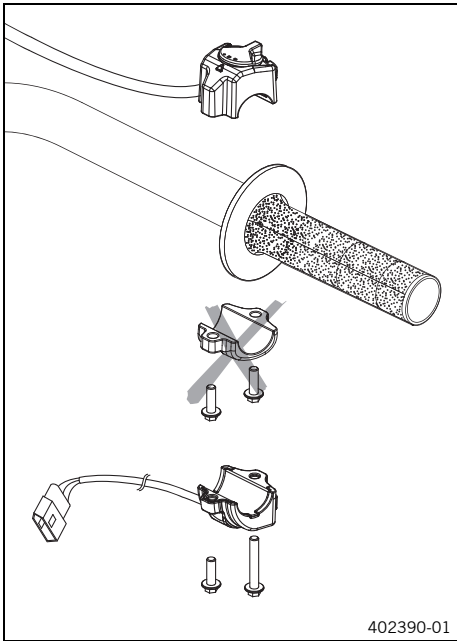

**(EXC-F EU/AU/BR, All Six Days models)**

- Mount the turn signal switch.



**Condition**

**Packaging V12**

- Connect all plug-in connectors to the connector retainer.
- Route the cable without tension and secure with cable tie.

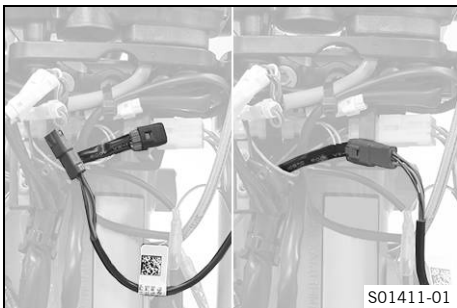

**(All Six Days models)**



**Warning**

**Voiding of the government approval for road use and the insurance coverage** If the combination switch is installed, the vehicle's approval for road use is invalidated.

- Only operate the vehicle in closed-off areas remote from public road traffic if the combination switch is installed.

- (Optional) Remove the protection cap and join the combination switch plug-in connector.

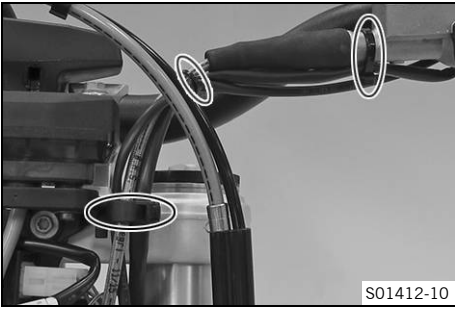

- Route the cable without tension and secure with cable ties and cable holder.

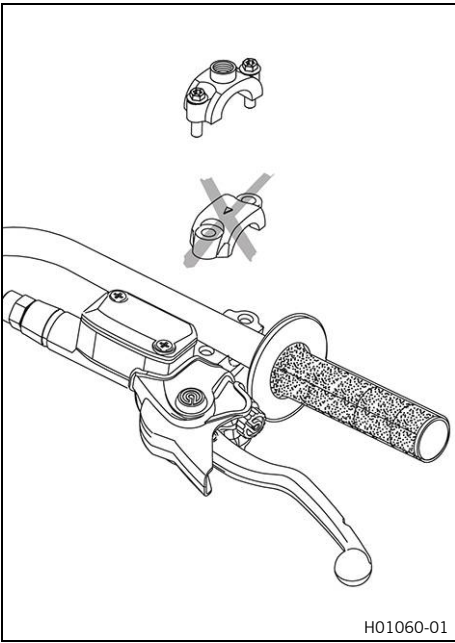

- Mount the mirror clamps on both sides.

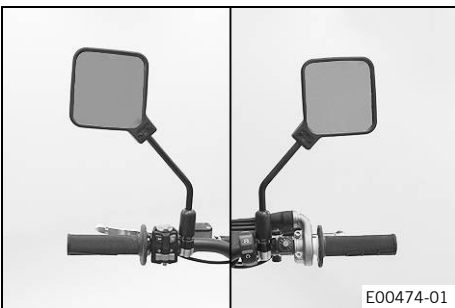

- Mount both rear mirrors with the adapter.



- Preassemble the hand guards on the left and right.



- Mount the left hand guard.
- Mount the right hand guard.

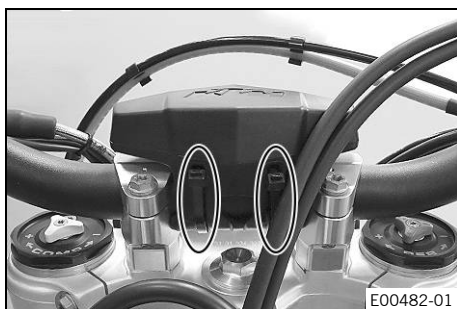

- Secure the handlebar cushion with two cable ties.
  - Install front fender. (📖 p. 26)
  - Install the front wheel. (📖 p. 25)
- (EXC-F EU/AU/US, EXC-F Six Days EU)**
- Remove the battery. (📖 p. 27)
  - Recharge the battery. (📖 p. 29)

(All BR models)



### Warning

**Risk of injury** Battery acid and battery gases cause serious chemical burns.

- Keep batteries out of the reach of children.
- Wear suitable protective clothing and safety glasses.
- Avoid contact with battery acid and battery gases.
- Keep sparks or open flames away from the battery.
- Only charge batteries in well-ventilated rooms.
- Rinse the affected area immediately with plenty of water in the event of contact with the skin.
- Rinse eyes with water for at least 15 minutes and consult a doctor immediately if battery acid and battery gases get into the eyes.

- Fill the battery.



### Info

Read the notes in the battery package.

- Recharge the battery. (📖 p. 31)

### (EXC-F US)

- Install the headlight mask with the headlight. (📖 p. 21)
- Install the battery. (📖 p. 29)

### (EXC-F EU/AU/BR, All Six Days models)

- Remove the fuel tank. (📖 p. 32)
- Position the turn signal wiring harness.
- Insert the indicator lamp with the black and violet cable colors into socket **4**.

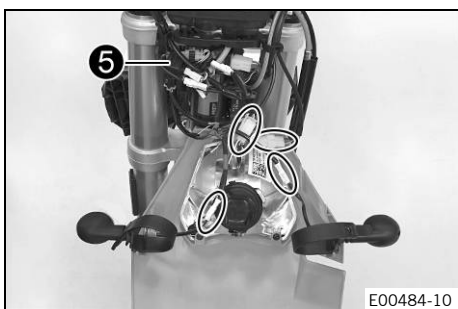

- Position turn signal on the headlight mask on both sides, mount and tighten nuts with washers.
- Join the plug-in connector of the right turn signal with the black and brown cables of the turn signal wiring harness.
- Join the plug-in connector of the left turn signal with the violet and brown cables of the turn signal wiring harness.



### Info

Pay attention to the brake lines routing when doing so.

- Join plug-in connector of the headlight.
- Join plug-in connector of the turn signal switch.

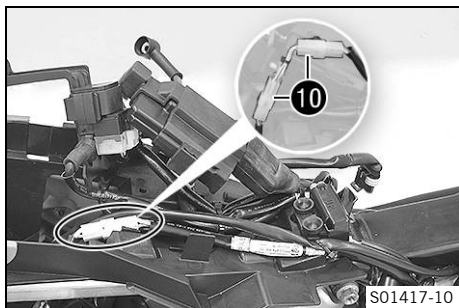
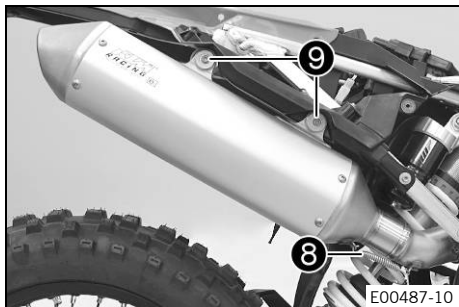
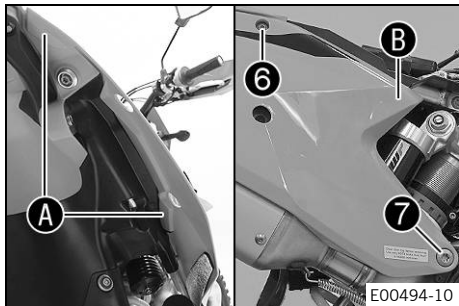
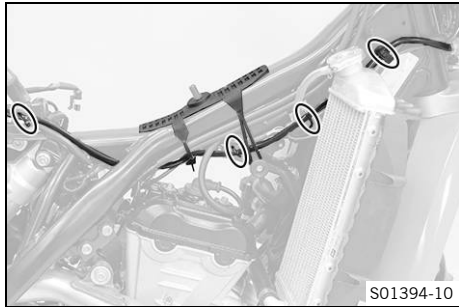

- Secure turn signal relay **5** with a cable tie and plug in the connector.
- Install the headlight mask with the headlight. (📖 p. 21)
- Route the turn signal wiring harness from front to back as far as the battery compartment.
- Position and secure the turn signal wiring harness under the rubber bands of the fuel tank contact area on the main wiring harness.

- Remove screw **6**.
- Remove screw **7**.
- Pull off the side cover in area **A** and in area **B** and remove it toward the rear.

- Detach spring **8**.

Spring hook (5030501700004)

- Remove screws **9** with washers and take off main silencer.

- Pull off engine electronics control unit from the holder and hang it to the side.
- Disconnect and remove plug-in connector **10** on the main wiring harness.
- Join the plug-in connector of the turn signal wiring harness with the plug-in connector of the main wiring harness.

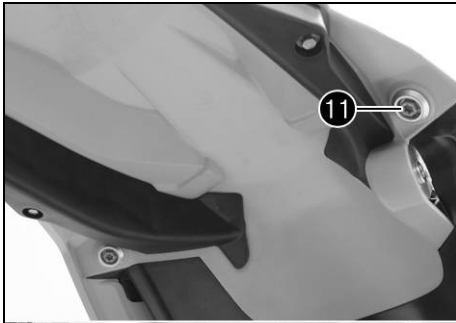

- Remove screw 11 with the collar sleeve.
- Remove screw 12.
- Remove screw 13 with negative cable and contact disk.

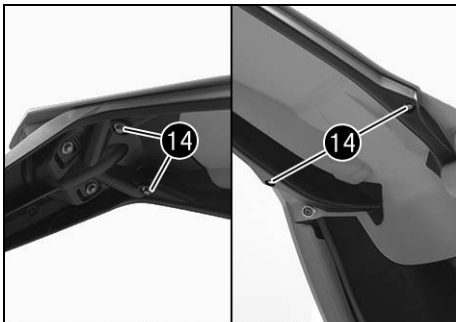
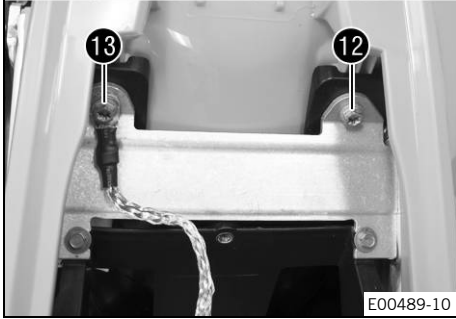

- Remove screws 14.
- Carefully remove the tail light cable from the frame and in doing so pay attention to the connector.
- Remove license plate holder with tail light to the rear.

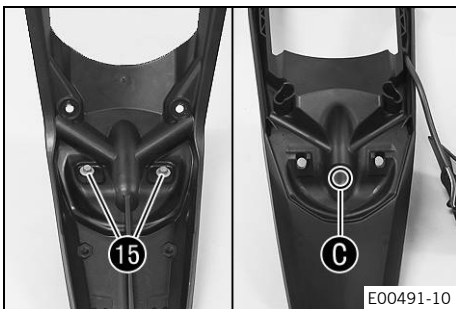
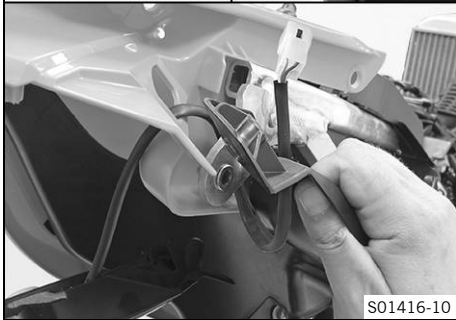

- Remove screws 15 and hang the tail light to the side.
- Drill a hole at the marking C the size of the marking.

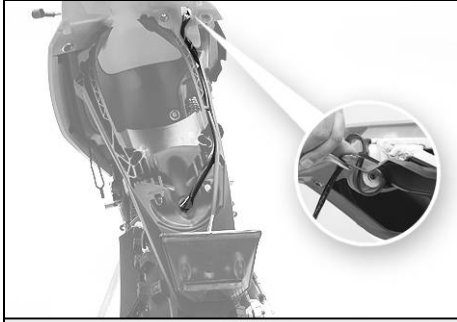

- Route the turn signal wiring harness toward to rear and pass through the frame, pay attention to the connector when doing so.
- Route the turn signal wiring harness on the license plate holder and pass the turn signal wiring harness through the hole.
- Position the tail light on the license plate holder and mount and tighten screws **15**.

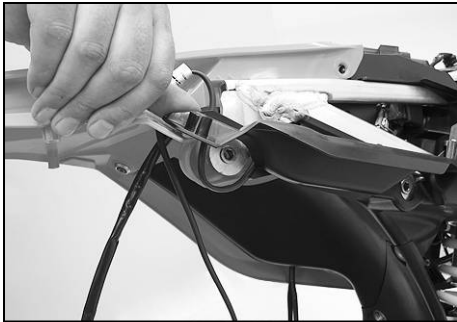

- Carefully guide the tail light cable through the frame and in doing so pay attention to the connector.
- Position license plate holder on the rear.
- Mount and tighten screws **14**.

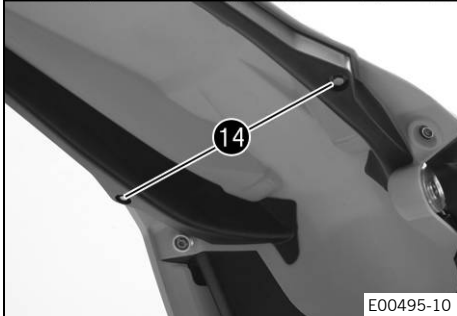





- Mount and tighten screw **11** with the collar bushing.

Guideline

Remaining screws, chassis	M6	10 Nm (7.4 lbf ft)
---------------------------	----	--------------------

- Mount and tighten screw **12**.

Guideline

Remaining screws, chassis	M6	10 Nm (7.4 lbf ft)
---------------------------	----	--------------------

- Mount and tighten screw **13** with negative cable and contact disk.

Guideline

Remaining screws, chassis	M6	10 Nm (7.4 lbf ft)
---------------------------	----	--------------------

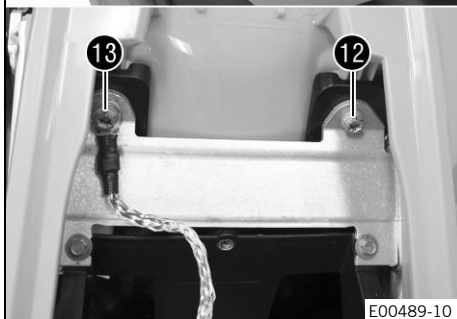

E00489-10

- Join the plug-in connector of the tail light with the plug-in connector of the turn signal wiring harness.
- Mount engine electronics control unit on the holder.



### Info

The wiring harness runs under the engine electronics control unit.



E00498-10

- Position the main silencer. Mount screws **9** with the washers, but do not tighten yet.
- Attach spring **8**.

Spring hook (5030501700004)

- Tighten screws **9**.

Guideline

Remaining screws, chassis	M6	10 Nm (7.4 lbf ft)
---------------------------	----	--------------------

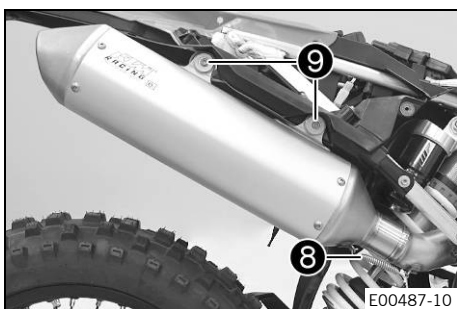

E00487-10

- Attach the side cover in area **A** and engage it in area **B**.
- Mount and tighten screw **7**.

Guideline

Screw, sub-frame	M8	35 Nm (25.8 lbf ft) <b>Loctite®2701™</b>
------------------	----	---------------------------------------------

- Mount and tighten screw **6**.

Guideline

Remaining screws, chassis	M6	10 Nm (7.4 lbf ft)
---------------------------	----	--------------------

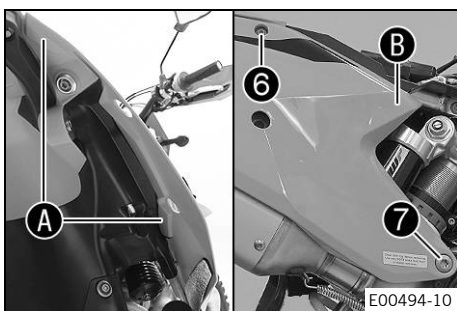

E00494-10

- Install the battery. (🗨 p. 29)
- Install the fuel tank. (🗨 p. 34)

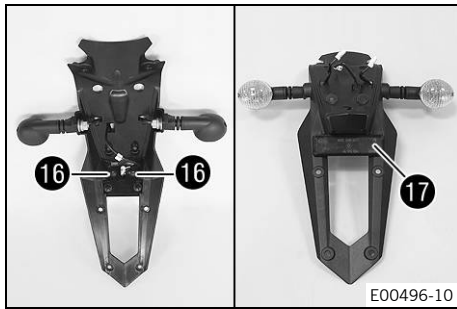

- Position turn signal on both sides, mount and tighten nuts with washers.
- Position license plate lamp on the license plate holder, mount and tighten screws 16.
- Mount reflector 17 on the license plate holder.
- Guide cable through the license plate holder.

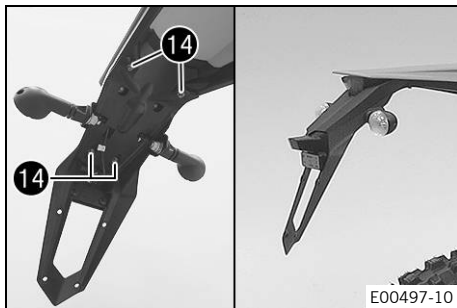

- Position license plate holder on the license plate bracket.
- Join the plug-in connector of the license plate lamp.
- Join the plug-in connector of the left turn signal which is marked red.
- Join the plug-in connector of the right turn signal which is marked green.
- Mount and tighten screws 14.

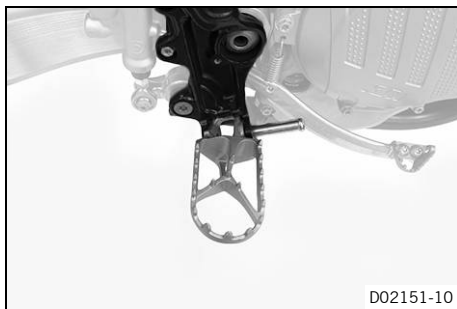

- Position the right footrest and pin.



### Info

Only insert the pins to the extent that the spring can still be mounted.

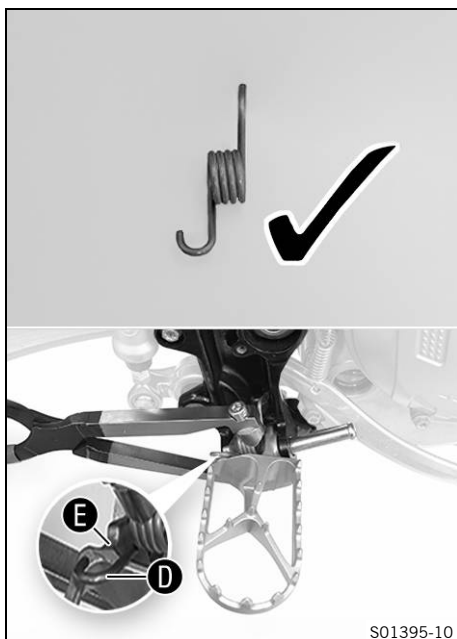

- Position spring as shown.
  - ✓ Spring D engages in area E.

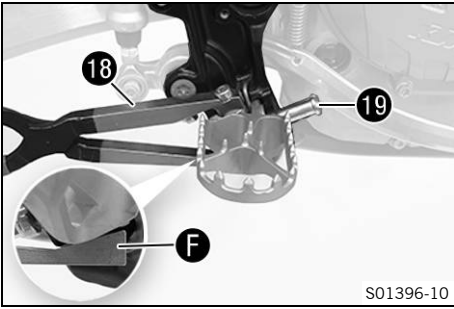

- Press the spring with special tool 18.

Footrest spring plier (79029083000)

- ✓ The special tool is applied to area F on the footrest.
- Mount pin 19.

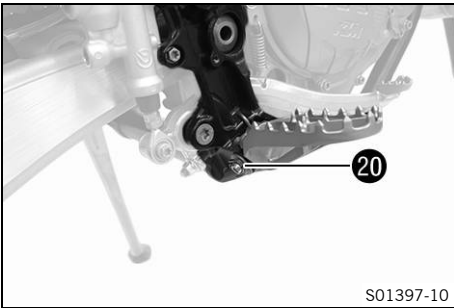

- Mount the washer and split pin 20.

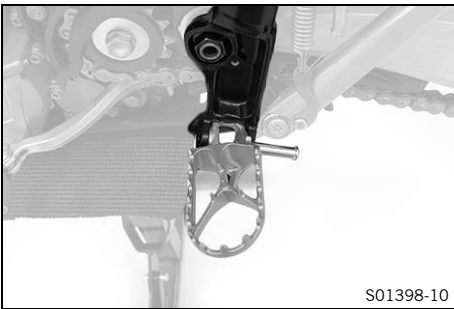

- Position the left footrest and pin.

---

**i Info**  
Only insert the pins to the extent that the spring can still be mounted.

---

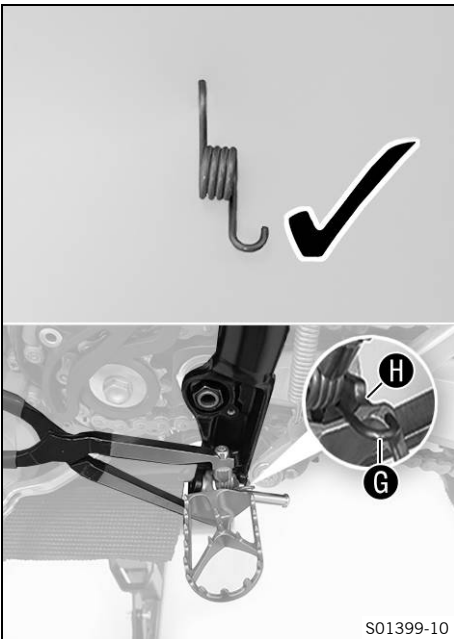

- Position spring as shown.
- ✓ Spring G engages in area H.

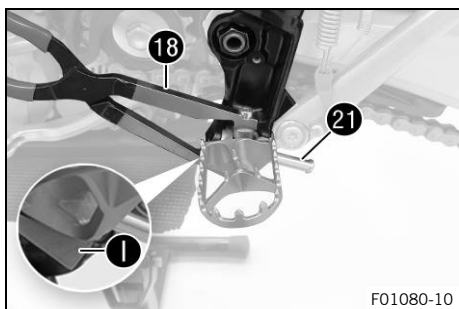

- Press the spring with special tool **18**.

Footrest spring plier (79029083000)

- ✓ The special tool is applied to area **1** on the footrest.

- Mount pin **21**.

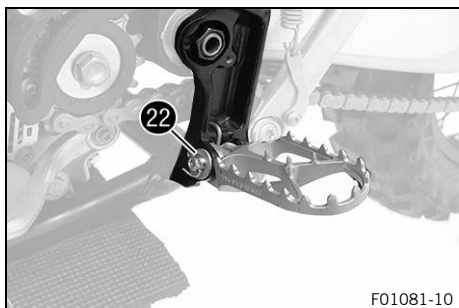

- Mount the washer and split pin **22**.

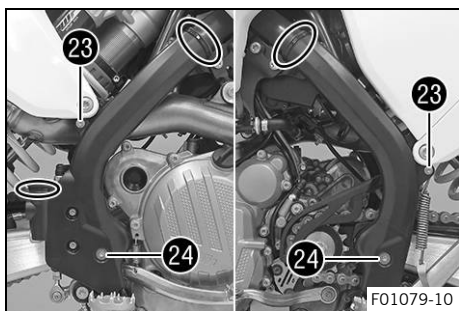

- Position the frame protector on both sides.

- Mount and tighten screws **23**.

Guideline

Screw, frame protector	M5	3 Nm (2.2 lbf ft)
------------------------	----	-------------------

- Mount and tighten screws **24** with the washers.

Guideline

Screw, frame protector	M5	3 Nm (2.2 lbf ft)
------------------------	----	-------------------

- Mount the cable binder.

### (EXC-F AU, All Six Days models)

- Install the engine guard. (📖 p. 37)

- Unpack and mount the **KTM PowerParts** included in the delivery (optional).



### Info

Read the accompanying **KTM PowerParts** fitting instructions.

- Apply the label included in the delivery (optional).
- Set kilometers or miles. (📖 p. 39)
- Adjust the combination instrument. (📖 p. 40)
- Set the clock. (📖 p. 40)
- Refuel. (📖 p. 38)
- Position all controls in their exact positions on the handlebar. Tighten all screws.
- Prepare the vehicle according to the specifications in the **KTM Dealer.net** for handover to the customer.

**Info**

In order to be able to start the motorcycle, the transport mode must be deactivated.

---



## 3.1 Raising the motorcycle with the lift stand

### Note

**Danger of damage** The parked vehicle can roll away or fall over.

- Park the vehicle on a firm and level surface.

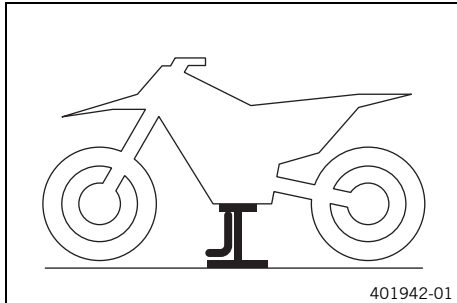

- Raise the motorcycle at the frame underneath the engine.

Lift stand (78129955100)

- ✓ Neither wheel is in contact with the ground.
- Secure the motorcycle against falling over.

## 3.2 Removing the motorcycle from the lift stand

### Note

**Danger of damage** The parked vehicle can roll away or fall over.

- Park the vehicle on a firm and level surface.

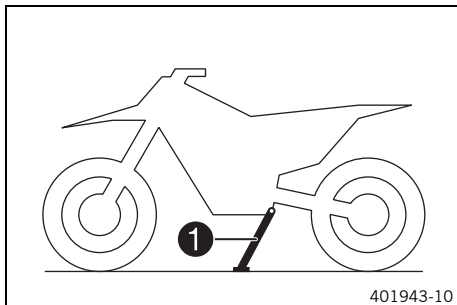

- Remove the motorcycle from the lift stand.
- Remove the lift stand.
- To park the motorcycle, press side stand ① to the ground with your foot and lean the motorcycle on it.



### Info

While riding, the side stand must be folded up and secured with the rubber band.

## 3.3 Removing the headlight mask with the headlight

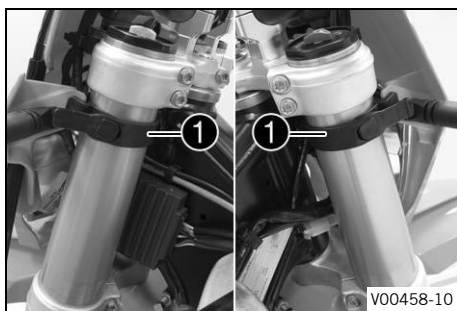

(EXC-F EU/AU/BR, All Six Days models)

- Detach the brake line and wiring harness from the headlight mask.
- Release rubber bands ①. Slide the headlight mask up and swing it forward.

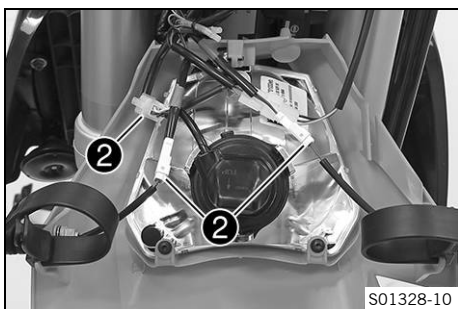

- Detach plug-in connectors **2** and take off the headlight mask with the headlight.

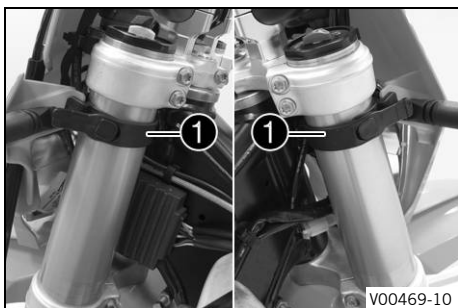

**(EXC-F US)**

- Detach the brake line and wiring harness from the headlight mask.
- Release rubber bands **1**. Slide the headlight mask up and swing it forward.

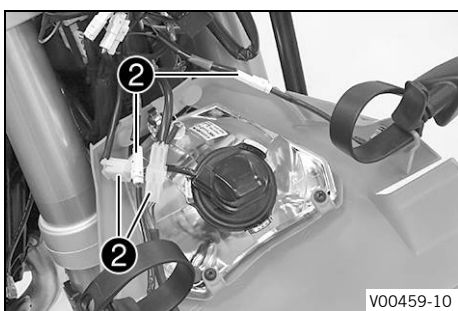

- Detach plug-in connectors **2** and take off the headlight mask with the headlight.

**3.4 Installing the headlight mask with the headlight**

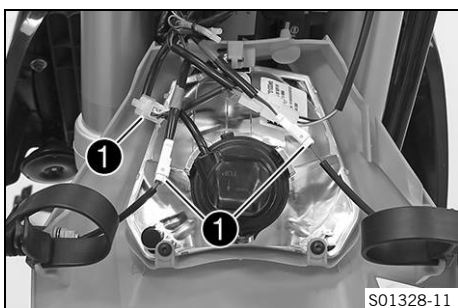

**Main work**

**(EXC-F EU/AU/BR, All Six Days models)**

- Connect plug-in connectors **1**.

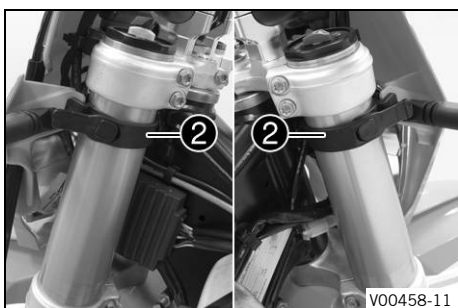

- Position the headlight mask and fix it with rubber bands **2**.
  - ✓ The holding lugs engage in the fender.
- Position the brake line and wiring harness in the brake line guide.

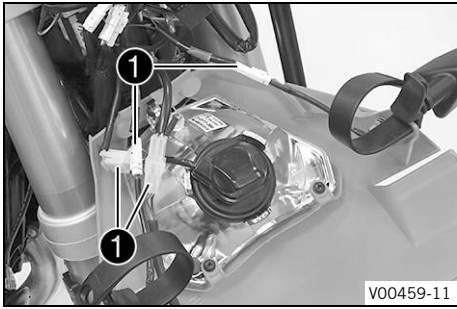

V00459-11

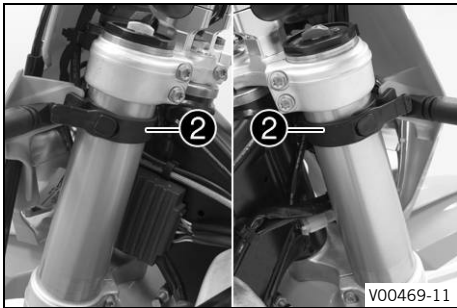

V00469-11

**(EXC-F US)**

- Connect plug-in connectors ①.
- Position the headlight mask and fix it with rubber bands ②.
  - ✓ The holding lugs engage in the fender.
- Position the brake line and wiring harness in the brake line guide.

**Finishing work**

- Check the headlight setting. (📖 p. 22)

## 3.5 Checking the headlight setting

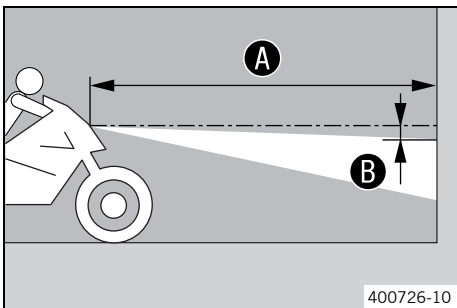

400726-10

- Position the vehicle upright on a horizontal surface in front of a light wall and make a mark at the height of the center of the low beam headlight.
- Make another mark at a distance ② under the first mark.

Guideline

Distance ②	5 cm (2 in)
------------	-------------

- Position the vehicle vertically at a distance ① away from the wall.

Guideline

Distance ①	5 m (16 ft)
------------	-------------

- The rider now sits down on the motorcycle.
- Switch on the low beam.
- Check the headlight setting.

The boundary between light and dark must be exactly on the lower mark for a motorcycle with rider.

- » If the light-dark border does not meet specifications:
  - Adjust the headlight range. (📖 p. 23)



### 3.6 Adjusting the headlight range

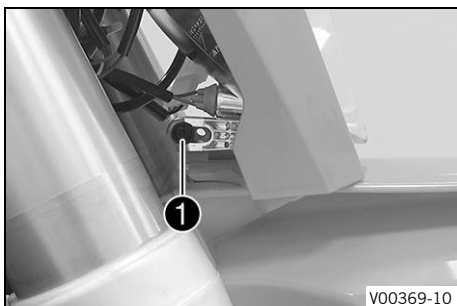

**Preparatory work**

- Check the headlight setting. (📖 p. 22)

**Main work**

- Loosen screw ❶.
- Adjust the headlight range by pivoting the headlight.

**Guideline**

The boundary between light and dark must be exactly on the lower marking for a motorcycle with rider (instructions on how to apply the marking: Checking the headlight setting).



**Info**

A change in weight on the vehicle may require a correction of the headlight range.

- Tighten screw ❶.



### 3.7 Installing the shock absorber

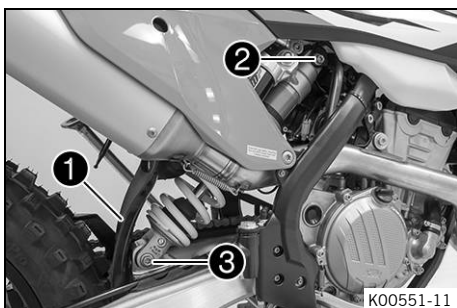

**Main work**

- Push splash protector ❶ to the side and position the shock absorber. Mount and tighten screw ❷.

**Guideline**

Screw, top shock absorber	M12	80 Nm (59 lbf ft) <b>Loctite®2701™</b>
---------------------------	-----	-------------------------------------------

- Mount and tighten screw ❸.

**Guideline**

Screw, bottom shock absorber	M12	80 Nm (59 lbf ft) <b>Loctite®2701™</b>
------------------------------	-----	-------------------------------------------



**Info**

The heim joint for the shock absorber at the swing arm is Teflon coated. It must not be greased with grease or with other lubricants. Lubricants dissolve the Teflon coating, thereby drastically reducing the service life.

**Finishing work**

- Remove the motorcycle from the lift stand. (📖 p. 20)



## 3.8 Installing the fork legs

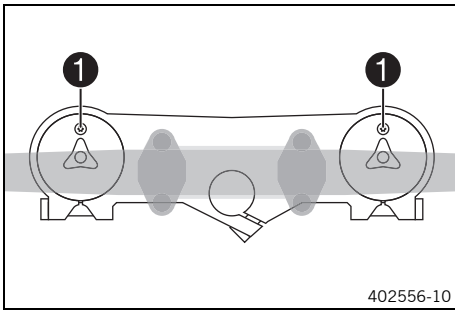

### Main work (EXC-F EU/AU/US/BR)

- Position the fork legs.
  - ✓ Bleeder screws **1** are positioned toward the front.

**i Info**  
Grooves are milled into the side of the upper end of the fork legs. The second milled groove (from the top) must be flush with the top edge of the upper triple clamp.

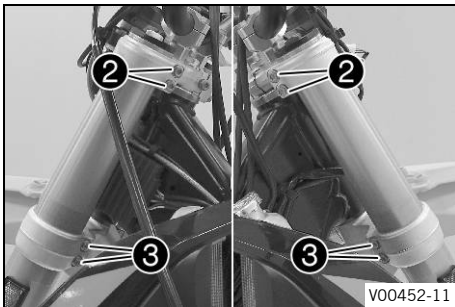

- Tighten screws **2**.

#### Guideline

Screw, top triple clamp	M8	20 Nm (14.8 lbf ft)
-------------------------	----	------------------------

- Tighten screws **3**.

#### Guideline

Screw, bottom triple clamp	M8	15 Nm (11.1 lbf ft)
----------------------------	----	------------------------

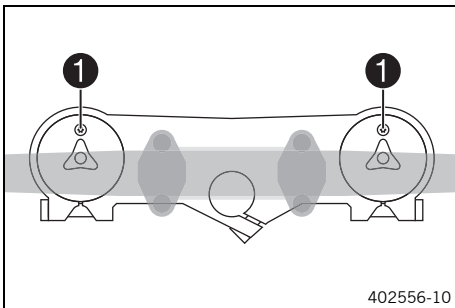

### (All Six Days models)

- Position the fork legs.
  - ✓ Bleeder screws **1** are positioned toward the front.

**i Info**  
The rebound damping is located in right fork leg **REB** (red adjusting screw). The compression damping is located in left fork leg **COM** (white adjusting screw).  
Grooves are milled into the side of the upper end of the fork legs. The second milled groove (from the top) must be flush with the top edge of the upper triple clamp.

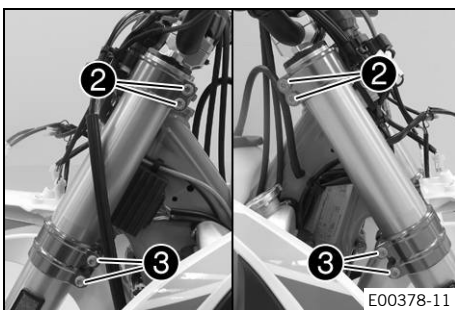

- Tighten screws **2**.

#### Guideline

Screw, top triple clamp	M8	17 Nm (12.5 lbf ft)
-------------------------	----	------------------------

- Tighten screws **3**.

#### Guideline

Screw, bottom triple clamp	M8	15 Nm (11.1 lbf ft)
----------------------------	----	------------------------

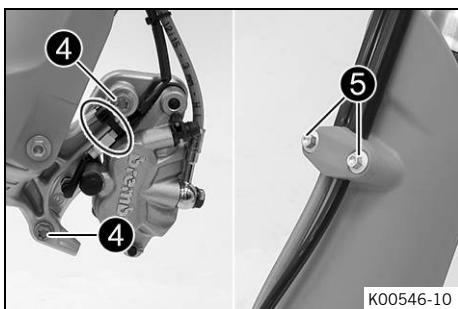

- Position the brake caliper, and mount and tighten screws ④.

Guideline

Screw, front brake caliper	M8	25 Nm (18.4 lbf ft) <b>Loctite®243™</b>
----------------------------	----	--------------------------------------------

- Mount the cable tie(s).
- Position the brake line, wiring harness, and clamp. Mount and tighten screws ⑤.

**Finishing work**

- Install the front wheel. (📖 p. 25)
- Install the headlight mask with the headlight. (📖 p. 21)
- Check the headlight setting. (📖 p. 22)

**3.9 Installing the front wheel**



**Warning**

**Danger of accidents** Oil or grease on the brake discs reduces the braking effect.

- Always keep the brake discs free of oil and grease.
- Clean the brake discs with brake cleaner when necessary.

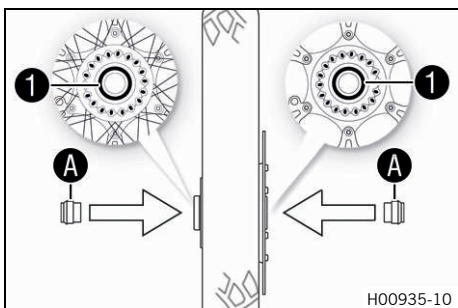

- Check the wheel bearing for damage and wear.
  - » If the wheel bearing is damaged or worn:
    - Change front wheel bearing.
- Clean and grease shaft seal rings ① and contact surface A of the spacers.

Long-life grease (📖 p. 45)
----------------------------

- Clean and grease the wheel spindle.

Long-life grease (📖 p. 45)
----------------------------

- Insert the spacers.
- Position the front wheel and insert the wheel spindle.
  - ✓ The brake linings are correctly positioned.

- Mount and tighten screw ②.

Guideline

Screw, front wheel spindle	M20x1.5	35 Nm (25.8 lbf ft)
----------------------------	---------	---------------------

- Operate the hand brake lever several times until the brake linings are seated correctly against the brake disc.
- Remove the motorcycle from the lift stand. (📖 p. 20)
- Operate the front brake and compress the fork a few times firmly.
  - ✓ The fork legs straighten.

- Tighten screws ③.

Guideline

Screw, fork stub	M8	15 Nm (11.1 lbf ft)
------------------	----	---------------------

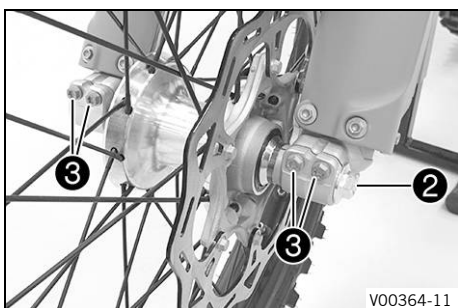

## 3.10 Installing front fender

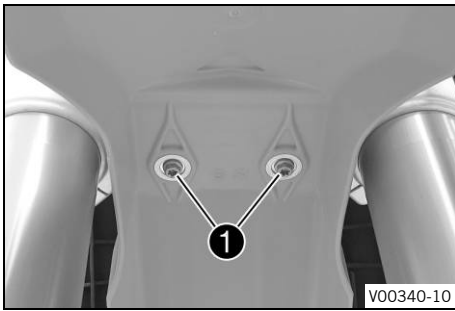

### Main work (EXC-F EU/AU/US/BR)

- Position front fender. Mount and tighten screws ❶.

Guideline

Remaining screws, chassis	M6	10 Nm (7.4 lbf ft)
---------------------------	----	--------------------

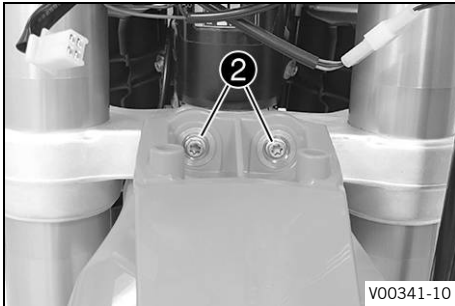

- Mount and tighten screws ❷.

Guideline

Remaining screws, chassis	M6	10 Nm (7.4 lbf ft)
---------------------------	----	--------------------

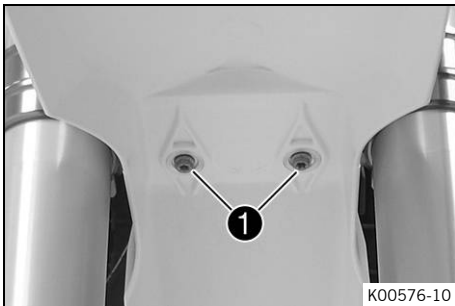

### (All Six Days models)

- Position front fender. Mount and tighten screws ❶.

Guideline

Remaining screws, chassis	M6	10 Nm (7.4 lbf ft)
---------------------------	----	--------------------

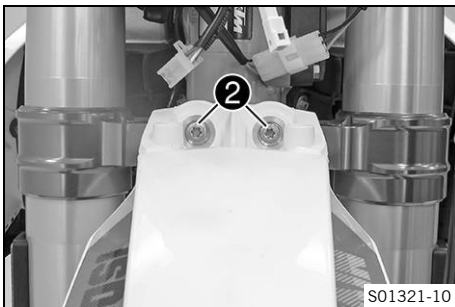

- Mount and tighten screws ❷.

Guideline

Remaining screws, chassis	M6	10 Nm (7.4 lbf ft)
---------------------------	----	--------------------

### Finishing work

- Install the headlight mask with the headlight. (📖 p. 21)
- Check the headlight setting. (📖 p. 22)

### 3.11 Removing the seat

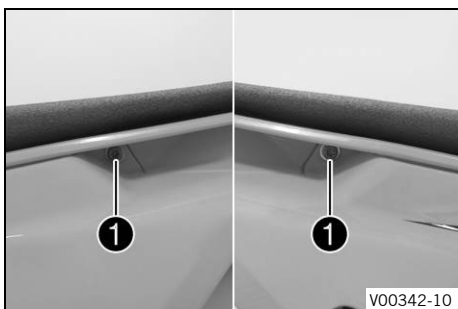

- Remove screws ①.
- Raise the rear of the seat, pull the seat back, and lift it off.

### 3.12 Mounting the seat

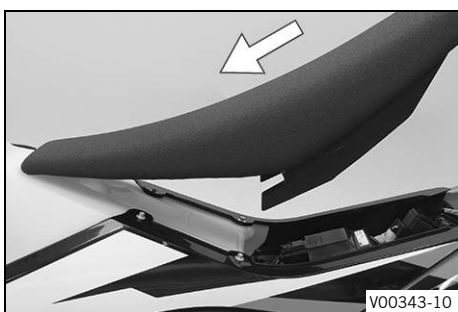

- Mount the front of the seat on the collar bushing of the fuel tank, lower the seat at the rear, and push the seat forward.
- Make sure that the seat is correctly locked in.

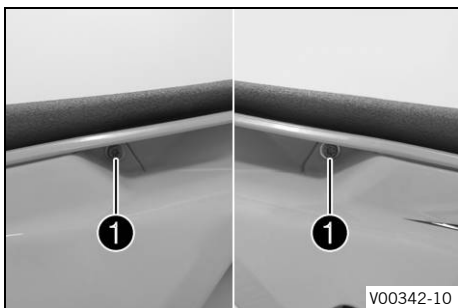

- Mount and tighten screws ①.

Guideline

Remaining screws, chassis	M6	10 Nm (7.4 lbf ft)
---------------------------	----	--------------------

### 3.13 Removing the battery



**Note**

**Environmental hazard** Batteries contain environmentally-hazardous materials.

- Do not dispose of batteries as household waste.
- Dispose of batteries at a collection point for used batteries.



**Note**

**Environmental hazard** Hazardous substances cause environmental damage.

- Dispose of oils, grease, filters, fuel, cleaning agents, brake fluid, etc., correctly and in compliance with the applicable regulations.

**Preparatory work**

**(EXC-F EU/AU/BR, All Six Days models)**

- Press and hold the kill switch ☒ while the engine is idling until the engine stops.

**(EXC-F US)**

- Turn the key in the ignition lock to the position ☒ while the engine is idling.
- Remove the seat. (📖 p. 27)

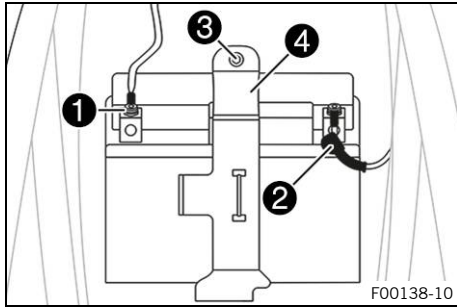

## Main work (EXC-F EU/AU/US, EXC-F Six Days EU)



### Warning

**Risk of injury** Batteries contain harmful substances.

- Keep batteries out of the reach of children.
- Keep sparks and open flames away from the batteries.
- Only charge batteries in well-ventilated rooms.
- Maintain a minimum clearance from inflammable materials when charging batteries.  
Minimum clearance 1 m (3 ft)
- Do not charge deeply discharged batteries if charge is already below the minimum voltage.  
Minimum voltage 9 V  
before the start of the charge
- Dispose of batteries with less than the minimum voltage correctly.

- Disconnect negative cable ① from the battery.
- Pull back positive terminal cover ② and disconnect the positive cable from the battery.
- Remove screw ③.
- Pull holding bracket ④ forward and remove battery toward the top.

### (All BR models)



### Warning

**Risk of injury** Battery acid and battery gases cause serious chemical burns.

- Keep batteries out of the reach of children.
- Wear suitable protective clothing and safety glasses.
- Avoid contact with battery acid and battery gases.
- Keep sparks or open flames away from the battery.
- Only charge batteries in well-ventilated rooms.
- Rinse the affected area immediately with plenty of water in the event of contact with the skin.
- Rinse eyes with water for at least 15 minutes and consult a doctor immediately if battery acid and battery gases get into the eyes.

- Disconnect negative cable ① from the battery.
- Pull back positive terminal cover ② and disconnect the positive cable from the battery.
- Remove screw ③.

- Pull holding bracket ④ forward and remove battery toward the top.



### 3.14 Installing the battery

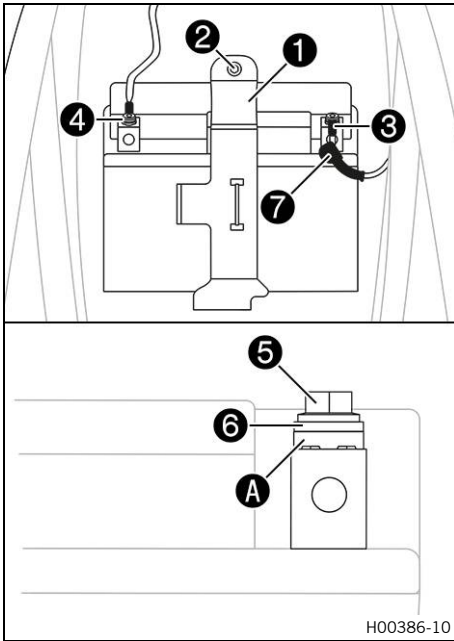

#### Main work

- Insert the battery into the battery compartment with the terminals facing forward and secure with holding bracket ①.

(EXC-F EU/AU/US, EXC-F Six Days EU)

Battery (HJTZ5S-FP-C)
-----------------------

(All BR models)

Battery (YTX5L-BS)
--------------------

- Mount and tighten screw ②.

#### Guideline

Remaining screws, chassis	M6	10 Nm (7.4 lbf ft)
---------------------------	----	--------------------

- Connect positive cable ③ to the battery.

#### Guideline

Screw, battery terminal	M5	2.5 Nm (1.84 lbf ft)
-------------------------	----	----------------------

- Slide positive terminal cover ⑦ over the positive terminal.

- Connect negative cable ④ to the battery.

#### Guideline

Screw, battery terminal	M5	2.5 Nm (1.84 lbf ft)
-------------------------	----	----------------------

Contact disks A must be mounted under screws ⑤ and cable sockets ⑥ with the claws toward the battery terminal.
----------------------------------------------------------------------------------------------------------------

#### Finishing work

- Mount the seat. (📖 p. 27)



### 3.15 Recharging the battery (EXC-F EU/AU/US, EXC-F Six Days EU)



#### Warning

**Risk of injury** Batteries contain harmful substances.

- Keep batteries out of the reach of children.
- Keep sparks and open flames away from the batteries.
- Only charge batteries in well-ventilated rooms.
- Maintain a minimum clearance from inflammable materials when charging batteries.  
Minimum clearance 1 m (3 ft)
- Do not charge deeply discharged batteries if charge is already below the minimum voltage.  
Minimum voltage before the start of the charge 9 V
- Dispose of batteries with less than the minimum voltage correctly.



**Note**

**Environmental hazard** Batteries contain environmentally-hazardous materials.

- Do not dispose of batteries as household waste.
- Dispose of batteries at a collection point for used batteries.



**Note**

**Environmental hazard** Hazardous substances cause environmental damage.

- Dispose of oils, grease, filters, fuel, cleaning agents, brake fluid, etc., correctly and in compliance with the applicable regulations.



**Info**

Even when there is no load on the battery, it discharges steadily. The charging level and the method of charging are very important for the service life of the battery. Rapid recharging with a high charging current shortens the service life of the battery. If the charging current, charging voltage, and charging time are exceeded, the battery will be destroyed. If the battery is depleted from starting the vehicle repeatedly, the battery must be charged immediately. If the battery is left in a discharged state for an extended period, it will become over-discharged and sulfated, destroying the battery. The battery is maintenance-free.

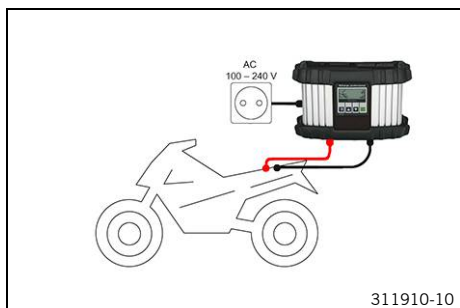

**Preparatory work**

- Remove the seat. (📖 p. 27)

**Main work**

- Connect the battery charger to the battery. Set the battery charger.

**Alternative 1**

EU battery charger **XCharge-professional**  
(00029095050)

**Alternative 2**

US battery charger **XCharge-professional**  
(00029095051)

**Alternative 3**

UK battery charger **XCharge-professional**  
(00029095052)

**Alternative 4**

CH battery charger **XCharge-professional**  
(00029095053)



**Info**

Follow the instructions of the charger and the manual.

- Disconnect the battery charger after charging the battery.

**Guideline**

The charging current, charging voltage, and charging time must not be exceeded.

Charge the battery regularly when the motorcycle is not in use	3 months
----------------------------------------------------------------	----------

**Finishing work**

- Mount the seat. (📖 p. 27)



3.16 Recharging the battery (All BR models)



**Warning**

**Risk of injury** Battery acid and battery gases cause serious chemical burns.

- Keep batteries out of the reach of children.
- Wear suitable protective clothing and safety glasses.
- Avoid contact with battery acid and battery gases.
- Keep sparks or open flames away from the battery.
- Only charge batteries in well-ventilated rooms.
- Rinse the affected area immediately with plenty of water in the event of contact with the skin.
- Rinse eyes with water for at least 15 minutes and consult a doctor immediately if battery acid and battery gases get into the eyes.



**Note**

**Environmental hazard** Batteries contain environmentally-hazardous materials.

- Do not dispose of batteries as household waste.
- Dispose of batteries at a collection point for used batteries.



**Note**

**Environmental hazard** Hazardous substances cause environmental damage.

- Dispose of oils, grease, filters, fuel, cleaning agents, brake fluid, etc., correctly and in compliance with the applicable regulations.



**Info**

Even when there is no load on the battery, it discharges steadily. The charging level and the method of charging are very important for the service life of the battery. Rapid recharging with a high charging current shortens the service life of the battery. If the charging current, charging voltage, or charging time are exceeded, the battery will be destroyed. If the battery is depleted by repeated starting, the battery must be charged immediately. If the battery is left in a discharged state for an extended period, over-discharge and sulfating occurs, destroying the battery. The battery is maintenance-free, i.e., the acid level does not have to be checked.

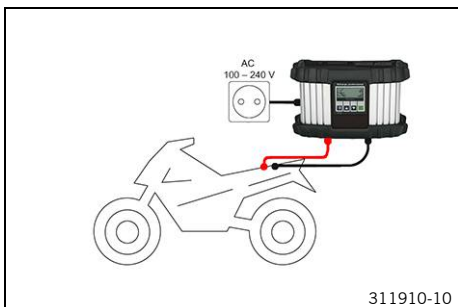

**Preparatory work**

- Remove the seat. (🔧 p. 27)

**Main work**

- Connect the battery charger to the battery. Set the battery charger.

**Alternative 1**

EU battery charger **XCharge-professional**  
(00029095050)

**Alternative 2**

US battery charger **XCharge-professional**  
(00029095051)

**Alternative 3**

UK battery charger **XCharge-professional**  
(00029095052)

**Alternative 4**

CH battery charger **XCharge-professional**  
(00029095053)



### Info

Follow the instructions of the charger and the manual.

- Disconnect the battery charger after charging the battery.

### Guideline

The charging current, charging voltage, and charging time must not be exceeded.

Charge the battery regularly when the motorcycle is not in use	3 months
----------------------------------------------------------------	----------

### Finishing work

- Mount the seat. (📖 p. 27)

## 3.17 Removing the fuel tank



### Danger

**Fire hazard** Fuel is highly flammable.

The fuel in the fuel tank expands when warm and can escape if overfilled.

- Do not refuel the vehicle in the vicinity of open flames or lit cigarettes.
- Switch off the engine for refueling.
- Make sure that no fuel is spilled; particularly not on hot parts of the vehicle.
- If any fuel is spilled, wipe it off immediately.
- Observe the specifications for refueling.



### Warning

**Danger of poisoning** Fuel is poisonous and a health hazard.

- Avoid skin, eye and clothing contact with fuel.
- Immediately consult a doctor if you swallow fuel.
- Do not inhale fuel vapors.
- In case of skin contact, rinse the affected area with plenty of water.
- Rinse the eyes thoroughly with water, and consult a doctor in case of fuel contact with the eyes.
- Change your clothing in case of fuel spills on them.
- Keep fuels correctly in a suitable canister, and out of the reach of children.

### Preparatory work

- Remove the seat. (📖 p. 27)

### Main work

- Unplug connector ❶ of the fuel pump.
- Remove the tube from the fuel tank breather.



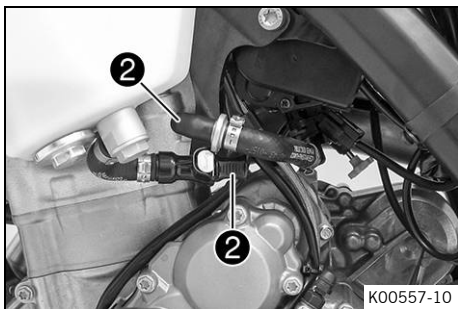

**(EXC-F EU/AU/BR, All Six Days models)**

- Thoroughly clean the plug-in connection of the fuel line using compressed air.

---

**i Info**  
Under no circumstances should dirt enter into the fuel line. Dirt in the fuel line clogs the injection valve!

---

- Disconnect the plug-in connection of the fuel line.

---

**i Info**  
Remaining fuel may flow out of the fuel line.

---

- Mount wash cap set **2**.

Wash cap set (81212016100)
----------------------------

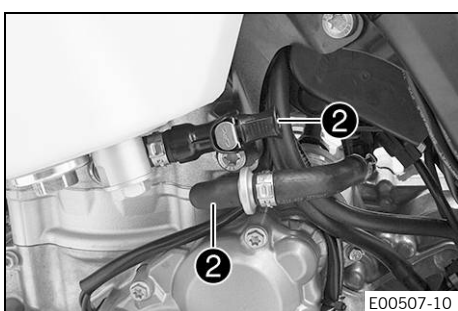

**(EXC-F US)**

- Thoroughly clean the plug-in connection of the fuel line using compressed air.

---

**i Info**  
Under no circumstances should dirt enter into the fuel line. Dirt in the fuel line clogs the injection valve!

---

- Disconnect the plug-in connection of the fuel line.

---

**i Info**  
Remaining fuel may flow out of the fuel line.

---

- Mount wash cap set **2**.

Wash cap set (81212016100)
----------------------------

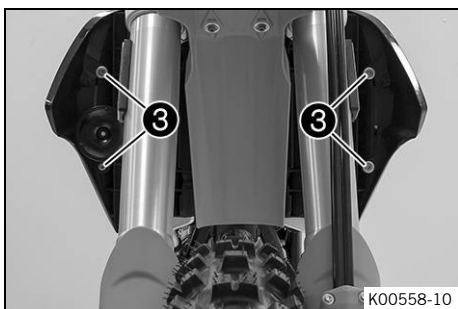

- Remove screws **3** with the collar bushings.



- Hang the horn and horn bracket to one side.
- Remove screw **4** with the rubber bushing.

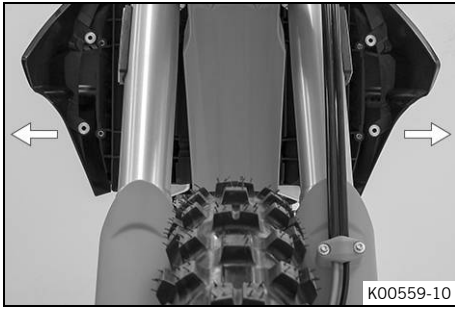

- Pull both spoilers off the sides of the radiator bracket and lift off the fuel tank.

## 3.18 Installing the fuel tank



### Danger

**Fire hazard** Fuel is highly flammable.

The fuel in the fuel tank expands when warm and can escape if overfilled.

- Do not refuel the vehicle in the vicinity of open flames or lit cigarettes.
- Switch off the engine for refueling.
- Make sure that no fuel is spilled; particularly not on hot parts of the vehicle.
- If any fuel is spilled, wipe it off immediately.
- Observe the specifications for refueling.



### Warning

**Danger of poisoning** Fuel is poisonous and a health hazard.

- Avoid skin, eye and clothing contact with fuel.
- Immediately consult a doctor if you swallow fuel.
- Do not inhale fuel vapors.
- In case of skin contact, rinse the affected area with plenty of water.
- Rinse the eyes thoroughly with water, and consult a doctor in case of fuel contact with the eyes.
- Change your clothing in case of fuel spills on them.

### Main work

- Check throttle cable routing. (📖 p. 36)
- Position the fuel tank and fit the two spoilers to the sides in front of the radiator bracket.
- Make sure that no cables or throttle cables are trapped or damaged.
- Attach the fuel tank breather hose.
- Mount and tighten screw **1** with the rubber bushing.

#### Guideline

Remaining screws, chassis	M6	10 Nm (7.4 lbf ft)
---------------------------	----	--------------------



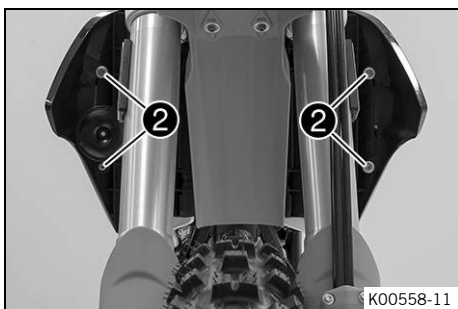

- Position the horn with the horn bracket.
- Mount and tighten screws ② with the collar bushings.

Guideline

Remaining screws, chassis	M6	10 Nm (7.4 lbf ft)
---------------------------	----	--------------------

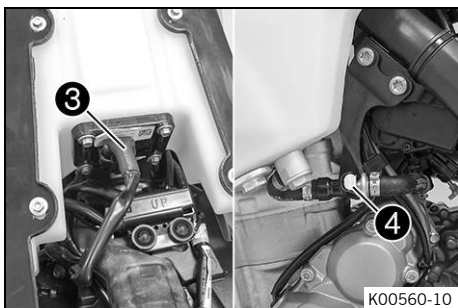

**(EXC-F EU/AU/BR, All Six Days models)**

- Plug in connector ③ for the fuel pump.
- Remove the wash cap set.
- Thoroughly clean the plug-in connection of the fuel line using compressed air.



**Info**

Under no circumstances should dirt enter into the fuel line. Dirt in the fuel line clogs the injection valve!

- Lubricate the O-ring and connect plug-in connection ④ for the fuel line.



**Info**

Route the cable and fuel line at a safe distance from the exhaust system.

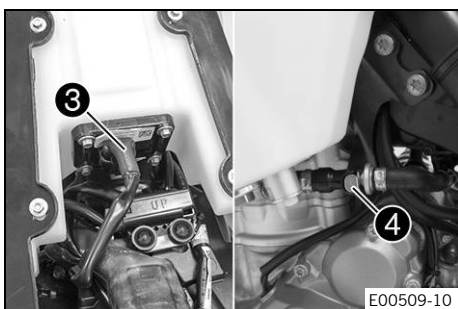

**(EXC-F US)**

- Plug in connector ③ for the fuel pump.
- Remove the wash cap set.
- Thoroughly clean the plug-in connection of the fuel line using compressed air.



**Info**

Under no circumstances should dirt enter into the fuel line. Dirt in the fuel line clogs the injection valve!

- Lubricate the O-ring and connect plug-in connection ④ for the fuel line.



**Info**

Route the cable and fuel line at a safe distance from the exhaust system.

**Finishing work**

- Mount the seat. (📖 p. 27)

## 3.19 Checking throttle cable routing

### Preparatory work

- Remove the seat. (📖 p. 27)
- Remove the fuel tank. (📖 p. 32)

### Main work

#### (EXC-F EU/AU/BR, All Six Days models)

- Check throttle cable routing.

Both throttle cables must be routed, side by side, on the back of the handlebars and above the fuel tank bracket, to the throttle valve body. Both throttle cables must be secured behind the fuel tank contact area rubber band.

- » If the throttle cable routing is not as specified:

- Correct throttle cable routing.

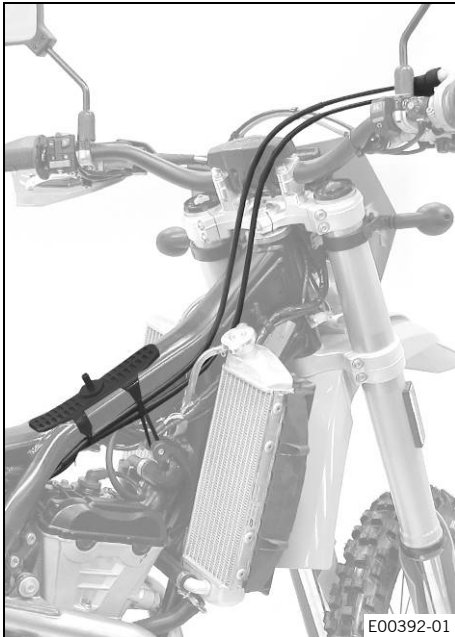

#### (EXC-F US)

- Check throttle cable routing.

Both throttle cables must be routed, side by side, on the back of the handlebars and above the fuel tank bracket, to the throttle valve body. Both throttle cables must be secured behind the fuel tank contact area rubber band.

- » If the throttle cable routing is not as specified:

- Correct throttle cable routing.

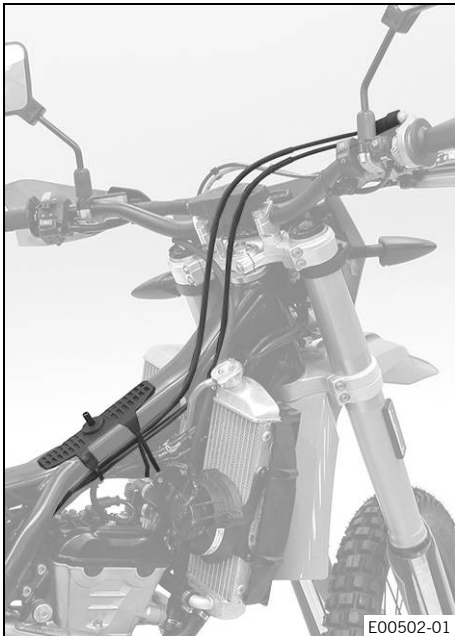

### Finishing work

- Install the fuel tank. (📖 p. 34)
- Mount the seat. (📖 p. 27)

**3.20 Installing the engine guard (EXC-F AU, All Six Days models)**

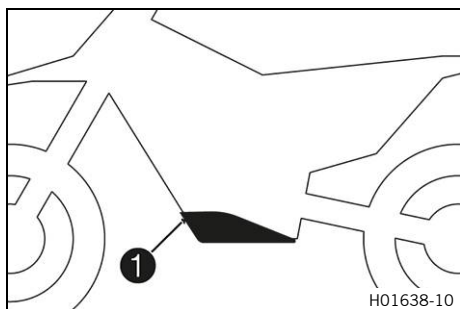

- Attach the engine guard on the frame at the rear and swing up at the front.
- Mount and tighten screws ❶.

Guideline

Remaining screws, chassis	M6	10 Nm (7.4 lbf ft)
---------------------------	----	--------------------

**3.21 Opening the filler cap**



**Danger**

**Fire hazard** Fuel is highly flammable.

The fuel in the fuel tank expands when warm and can escape if overfilled.

- Do not refuel the vehicle in the vicinity of open flames or lit cigarettes.
- Switch off the engine for refueling.
- Make sure that no fuel is spilled; particularly not on hot parts of the vehicle.
- If any fuel is spilled, wipe it off immediately.
- Observe the specifications for refueling.



**Warning**

**Danger of poisoning** Fuel is poisonous and a health hazard.

- Avoid skin, eye and clothing contact with fuel.
- Immediately consult a doctor if you swallow fuel.
- Do not inhale fuel vapors.
- In case of skin contact, rinse the affected area with plenty of water.
- Rinse the eyes thoroughly with water, and consult a doctor in case of fuel contact with the eyes.
- Change your clothing in case of fuel spills on them.
- Keep fuels correctly in a suitable canister, and out of the reach of children.



**Note**

**Environmental hazard** Improper handling of fuel is a danger to the environment.

- Do not allow fuel to enter the groundwater, the soil, or the sewage system.

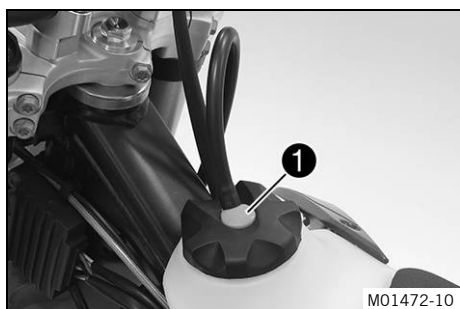

- Press release button ❶, turn the filler cap counterclockwise, and lift it off.

## 3.22 Closing the filler cap

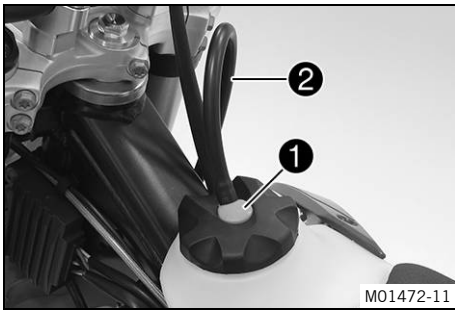

- Fit the filler cap and turn clockwise until release button ① locks in place.



### Info

Route fuel tank breather hose ② without kinks.

## 3.23 Refueling



### Danger

**Fire hazard** Fuel is highly flammable.

The fuel in the fuel tank expands when warm and can escape if overfilled.

- Do not refuel the vehicle in the vicinity of open flames or lit cigarettes.
- Switch off the engine for refueling.
- Make sure that no fuel is spilled; particularly not on hot parts of the vehicle.
- If any fuel is spilled, wipe it off immediately.
- Observe the specifications for refueling.



### Warning

**Danger of poisoning** Fuel is poisonous and a health hazard.

- Avoid skin, eye and clothing contact with fuel.
- Immediately consult a doctor if you swallow fuel.
- Do not inhale fuel vapors.
- In case of skin contact, rinse the affected area with plenty of water.
- Rinse the eyes thoroughly with water, and consult a doctor in case of fuel contact with the eyes.
- Change your clothing in case of fuel spills on them.

### Note

**Material damage** Inadequate fuel quality causes the fuel filter to quickly become clogged.

In some countries and regions, the available fuel quality and cleanliness may not be sufficient. This will result in problems with the fuel system.

- Refuel only with clean fuel that meets the specified standards.



### Note

**Environmental hazard** Improper handling of fuel is a danger to the environment.

- Do not allow fuel to enter the groundwater, the soil, or the sewage system.

- Switch off the engine.
- Open the filler cap. (🗨️ p. 37)



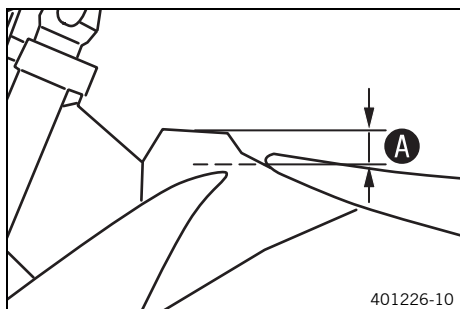

- Fill the fuel tank with fuel up to level **A**.

Guideline

Level <b>A</b>	35 mm (1.38 in)	
Total fuel tank capacity, approx.	8.5 l (2.25 US gal)	Super unleaded (ROZ 95/RON 95/PON 91) (📖 p. 44) (EXC-F EU/AU/US, EXC-F Six Days EU)
Total fuel tank capacity, approx.		Super unleaded, type C (ROZ 95/RON 95/PON 91) (📖 p. 44) (All BR models)

- Close the filler cap. (📖 p. 38)

### 3.24 Setting the kilometers or miles

**i** **Info**

If you change the unit, the value **ODO** is retained and converted accordingly. The values **TR1**, **TR2**, **A1**, **A2** and **S1** are cleared when the unit of measure is changed.

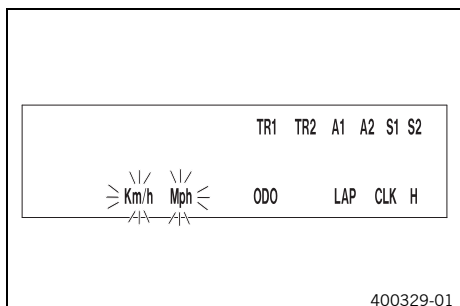

**Condition**

The motorcycle is stationary.

- Repeatedly press the button **+** briefly until **H** appears at the bottom right of the display.
- Press the button **+** for 2–3 seconds.
  - ✓ The Setup menu is displayed and the active functions are shown.
- Repeatedly press the button **+** briefly until **Km/h/Mph** flashes.

**Setting the Km/h**

- Press the button **+**.

**Setting the Mph**

- Press the button **-**.
- Wait 3 - 5 seconds.
  - ✓ The settings are stored.

**i** **Info**

If no button is pressed for 10 -12 seconds, or if an impulse comes from the wheel speed sensor, the settings are automatically saved and the setup menu is closed.

### 3.25 Adjusting the combination instrument

#### **i** Info

When the vehicle is delivered, only the **SPEED/H** and **SPEED/ODO** display modes are activated.

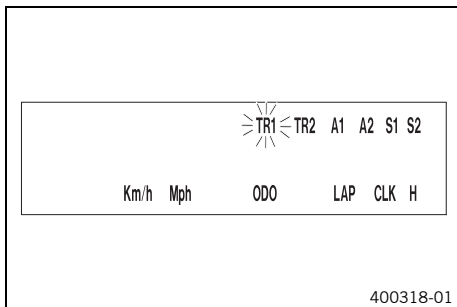

#### **Condition**

The motorcycle is stationary.

- Repeatedly press the button **+** briefly until **H** appears at the bottom right of the display.
- Press the button **+** for 2–3 seconds.
  - ✓ The Setup menu is displayed and the active functions are shown.

#### **i** Info

If no button is pressed for 10–12 seconds, the settings are automatically saved.  
If no button is pressed for 20 seconds, or if an impulse comes from the wheel speed sensor, the settings are automatically saved and the setup menu is closed.

- Repeatedly press the button **+** briefly until the desired function flashes.
  - ✓ The selected function flashes.

#### **Activating the function**

- Press the button **+**.
  - ✓ The symbol continues to appear in the display and the next function appears.

#### **Deactivating a function**

- Press the button **-**.
  - ✓ The symbol disappears in the display and the next function appears.

### 3.26 Setting the clock



#### **Condition**

The motorcycle is stationary.

- Repeatedly press the button **+** briefly until **CLK** appears at the bottom right of the display.
- Press the button **+** for 2–3 seconds.
  - ✓ The hour display flashes.
- Set the hour display with the button **+** and/or button **-**.
- Wait 3 - 5 seconds.
  - ✓ The next segment of the display flashes and can be set.
- You can set the following segments in the same way as the hours by pressing the button **+** and the button **-**.

**Info**

The seconds can only be set to zero.  
If no button is pressed for 15 -20 seconds, or if an impulse comes from the wheel speed sensor, the settings are automatically saved and the setup menu is closed.

---



## 4.1 Chassis tightening torques

Remaining screws, chassis	<b>EJOT PT®</b> K60x25-Z	2 Nm (1.5 lbf ft)
Screw, active carbon filter (EXC-F US)	-	5 Nm (3.7 lbf ft)
Screw, air filter box cover	<b>EJOT PT®</b> K60x20-Z	3 Nm (2.2 lbf ft)
Screw, combination switch (All Six Days models)	<b>EJOT PT®</b> K50x18 T20	2 Nm (1.5 lbf ft)
Screw, pressure regulator	<b>EJOT PT®</b> K60x25-Z	3 Nm (2.2 lbf ft)
Screw, seat fixing	<b>EJOT EJOFORM PT®</b> K60x23/18	2.5 Nm (1.84 lbf ft)
Screw, emergency OFF switch	M4	1 Nm (0.7 lbf ft)
Screw, fixed grip	M4	5 Nm (3.7 lbf ft) <b>Loctite®243™</b>
Spoke nipple, front wheel	M4.5	6 Nm (4.4 lbf ft)
Spoke nipple, rear wheel	M4.5	6 Nm (4.4 lbf ft)
Remaining nuts, chassis	M5	5 Nm (3.7 lbf ft)
Remaining screws, chassis	M5	5 Nm (3.7 lbf ft)
Screw, battery terminal	M5	2.5 Nm (1.84 lbf ft)
Screw, intake air temperature sensor	M5	3.5 Nm (2.58 lbf ft)
Screw, light switch	M5	1 Nm (0.7 lbf ft)
Screw, shock absorber adjusting ring	M5	5 Nm (3.7 lbf ft)
Nut, cable on starter motor	M6	4 Nm (3 lbf ft)
Remaining nuts, chassis	M6	10 Nm (7.4 lbf ft)
Remaining screws, chassis	M6	10 Nm (7.4 lbf ft)
Screw, ball joint of push rod on foot brake cylinder	M6	10 Nm (7.4 lbf ft) <b>Loctite®243™</b>
Screw, chain sliding guard	M6	14 Nm (10.3 lbf ft) <b>Loctite®243™</b>
Screw, front brake disc	M6	14 Nm (10.3 lbf ft) <b>Loctite®243™</b>
Screw, rear brake disc	M6	14 Nm (10.3 lbf ft) <b>Loctite®243™</b>
Screw, throttle grip	M6	5 Nm (3.7 lbf ft)
Fuel connection on fuel pump	M8	10 Nm (7.4 lbf ft)
Nut, foot brake lever	M8	15 Nm (11.1 lbf ft)
Nut, foot brake lever stop	M8	20 Nm (14.8 lbf ft)
Nut, rear sprocket screw	M8	35 Nm (25.8 lbf ft) <b>Loctite®2701™</b>
Nut, rim lock	M8	12 Nm (8.9 lbf ft)
Remaining nuts, chassis	M8	25 Nm (18.4 lbf ft)
Remaining screws, chassis	M8	25 Nm (18.4 lbf ft)
Screw, bottom triple clamp (All Six Days models)	M8	15 Nm (11.1 lbf ft)
Screw, bottom triple clamp (EXC-F EU/AU/US/BR)	M8	15 Nm (11.1 lbf ft)
Screw, chain sliding piece	M8	15 Nm (11.1 lbf ft)

Screw, engine brace	M8	25 Nm (18.4 lbf ft) <b>Loctite®2701™</b>
Screw, fork stub	M8	15 Nm (11.1 lbf ft)
Screw, front brake caliper	M8	25 Nm (18.4 lbf ft) <b>Loctite®243™</b>
Screw, handlebar clamp	M8	20 Nm (14.8 lbf ft)
Screw, manifold on cylinder head brace	M8	15 Nm (11.1 lbf ft)
Screw, side stand attachment	M8	35 Nm (25.8 lbf ft) <b>Loctite®2701™</b>
Screw, subframe	M8	35 Nm (25.8 lbf ft) <b>Loctite®2701™</b>
Screw, top steering stem (All Six Days models)	M8	17 Nm (12.5 lbf ft) <b>Loctite®243™</b>
Screw, top steering stem (EXC-F EU/AU/US/BR)	M8	20 Nm (14.8 lbf ft)
Screw, top triple clamp (All Six Days models)	M8	17 Nm (12.5 lbf ft)
Screw, top triple clamp (EXC-F EU/AU/US/BR)	M8	20 Nm (14.8 lbf ft)
Engine attachment bolt	M10	60 Nm (44.3 lbf ft)
Remaining nuts, chassis	M10	45 Nm (33.2 lbf ft)
Remaining screws, chassis	M10	45 Nm (33.2 lbf ft)
Screw, handlebar holder	M10	40 Nm (29.5 lbf ft) <b>Loctite®243™</b>
Nut, fuel pump fixation	M12	15 Nm (11.1 lbf ft)
Screw, bottom shock absorber	M12	80 Nm (59 lbf ft) <b>Loctite®2701™</b>
Screw, top shock absorber	M12	80 Nm (59 lbf ft) <b>Loctite®2701™</b>
SAS valve (EXC-F US)	M16	15 Nm (11.1 lbf ft)
Nut, swingarm pivot	M16x1.5	100 Nm (73.8 lbf ft)
Nut, rear wheel spindle	M20x1.5	80 Nm (59 lbf ft)
Screw, front wheel spindle	M20x1.5	35 Nm (25.8 lbf ft)
Screw, top steering head	M20x1.5	12 Nm (8.9 lbf ft)
Screw-in nozzles, cooling system	M20x1.5	12 Nm (8.9 lbf ft) <b>Loctite®243™</b>

### Super unleaded (ROZ 95/RON 95/PON 91)

#### Standard/classification

- DIN EN 228 (ROZ 95/RON 95/PON 91)

#### Guideline

- Only use unleaded super fuel that matches or is equivalent to the specified fuel grade.
- Fuel with an ethanol content of up to 10 % (E10 fuel) is safe to use.



#### Info

Do **not** use fuel containing methanol (e. g. M15, M85, M100) or more than 10 % ethanol (e. g. E15, E25, E85, E100).

### Super unleaded, type C (ROZ 95/RON 95/PON 91)

#### Standard/classification

- ANP (Agência Nacional do Petróleo) #57 (ROZ 95/RON 95/PON 91)

#### Guideline

- Only use super unleaded fuel that matches or is equivalent to the following specifications.
- Super unleaded fuel with an ethanol content of 19 to 27 % is permissible.



#### Info

Do **not** use fuel made of methanol (e. g. M15, M85, M100).

Do **not** use fuel with less than 19 % ethanol (e. g. E10).

Do **not** use fuel with more than 27 % ethanol (e. g. E30, E85, E100).

## Long-life grease

Recommended supplier

Motorex®

– Bike Grease 2000

**READY TO RACE**

>> [www.ktm.com](http://www.ktm.com)



3213898en

03/2018



**KTM**

**KTM Sportmotorcycle GmbH**  
5230 Mattighofen/Austria  
<http://www.ktm.com>



Photo: Mitterbauer/KTM