





250 SXS-F 2008

SPARE PARTS MANUAL: ENGINE

ART.NO.: 3CM089310HEN

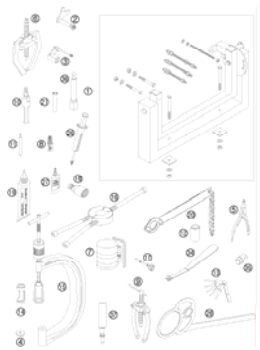
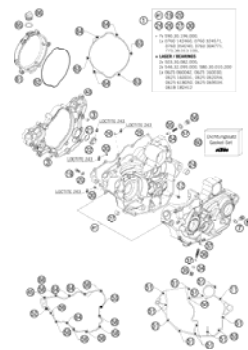
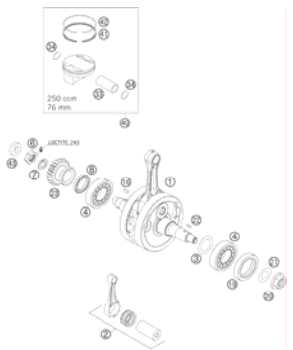
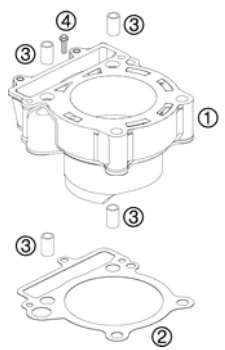
ENGLISH

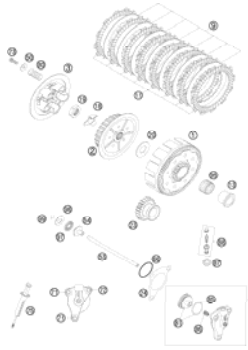

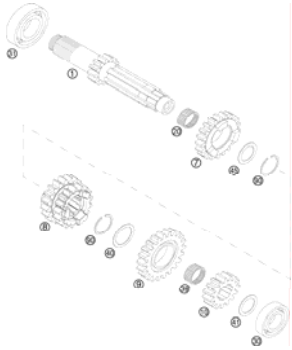
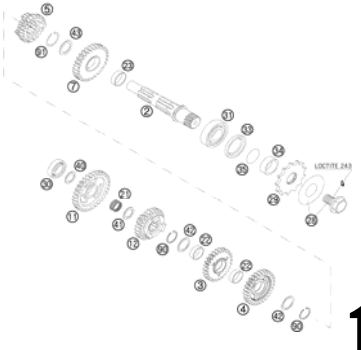
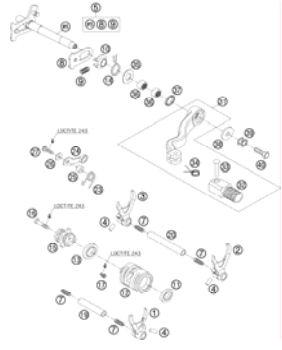
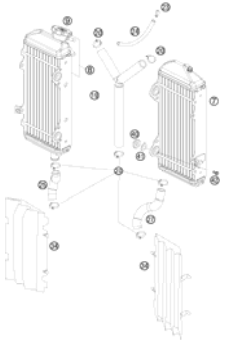
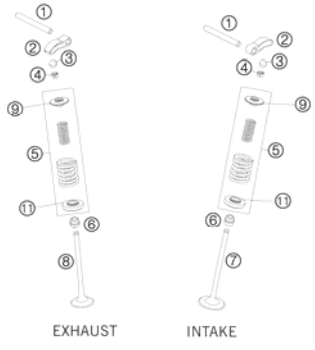
SPECIAL TOOLS  3	ENGINE CASE  4	CRANKSHAFT, PISTON  6	CYLINDER  7
CARBURETOR  8	CLUTCH  10	KICKSTARTER  11	TRANSMISSION I  12
TRANSMISSION II  13	SHIFTING MECHANISM  14	COOLING SYSTEM  15	VALVE DRIVE  EXHAUST INTAKE 16

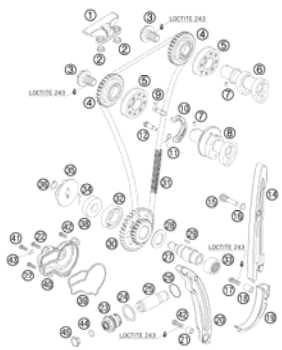
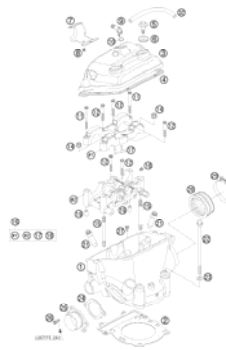
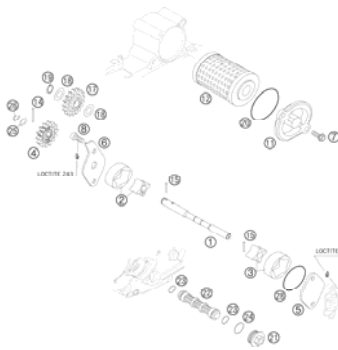
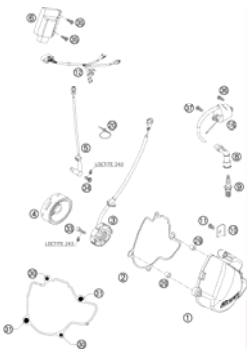
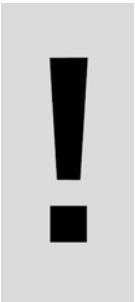
<p>TIMING VALVE</p>  <p style="text-align: right;">17</p>	<p>CYLINDER HEAD</p>  <p style="text-align: right;">19</p>	<p>LUBRICATING SYSTEM</p>  <p style="text-align: right;">20</p>	<p>IGNITION SYSTEM</p>  <p style="text-align: right;">21</p>
	<div style="display: flex; align-items: center;">  <p>All information contained is without obligation. KTM-Sportmotorcycle AG particularly reserves the right to modify any equipment, technical specifications, prices, colors, shapes, materials, services, service work, constructions, equipment and the like so as to adapt them to local conditions or to cancel any of the above items, all without previous announcement and without giving reasons. KTM may stop manufacturing certain models without previous notice. KTM shall not be held liable for any deviations of availability and/or ability to deliver, illustrations, descriptions, printing and/or other errors. The illustrated models partly contain extra equipment, which is not applied to standard models. © by KTM-SPORTMOTORCYCLE AG, Mattighofen AUSTRIA; All rights reserved; Reprint, also in extracts, with written allowance of KTM-SPORTMOTORCYCLE AG, Mattighofen only.</p> </div>		

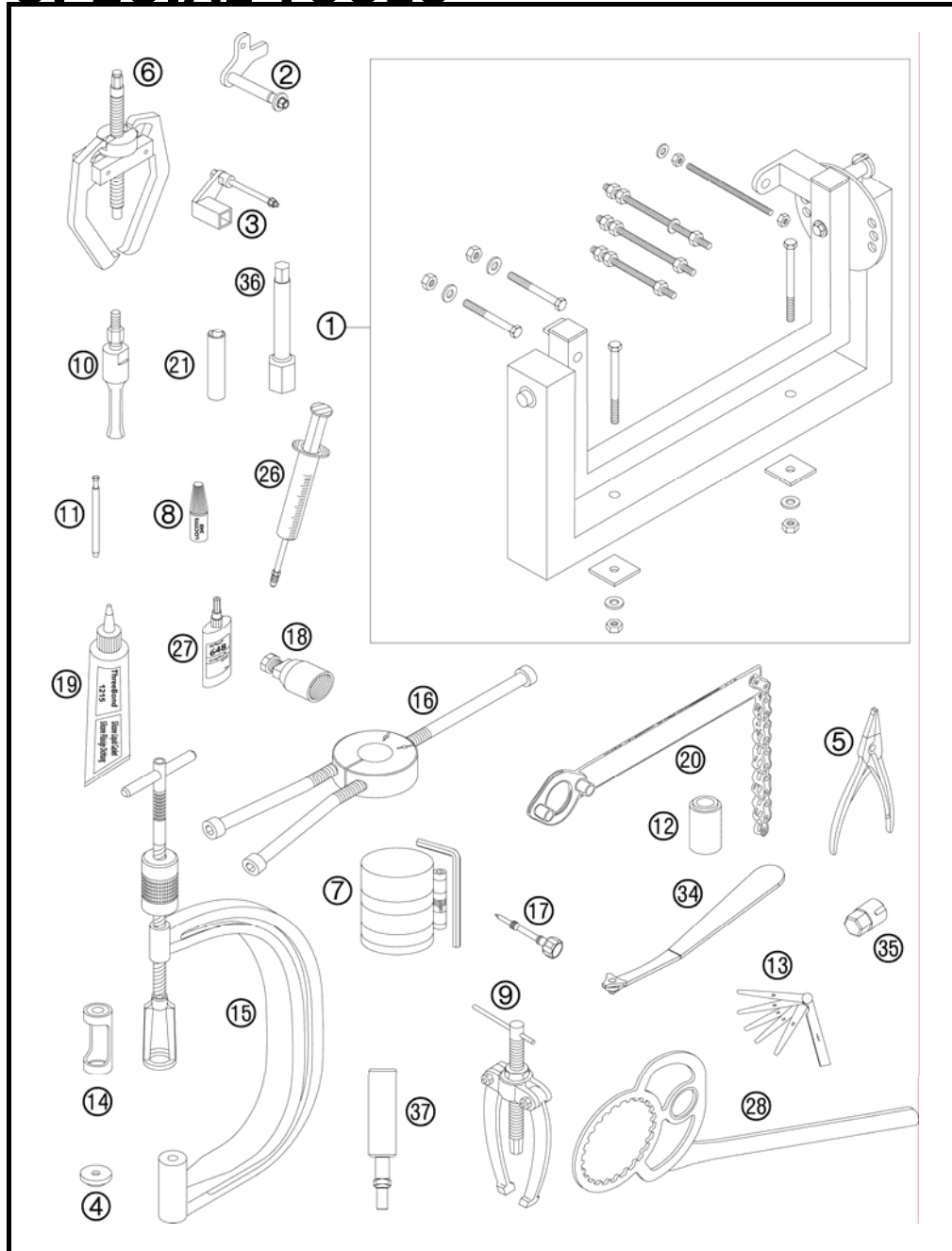

FIG	PART NUMBER	DESCRIPTION	QTY
1	56012001000	UNIVERSAL MOUNTING RACK '96	1
2	77029002000	FIXING ARM FRONT	1
3	77029003000	FIXING ARM REAR	1
4	77029035000	PROTECTION CAP FOR CAMSHAFT	1
5	51012011000	SPECIAL CIRCLIP PLIER	1
6	59029033000	EXTRACTOR FOR TIMING GEAR	1
7	60029015000	PISTON RING COMPRESSOR CPL. 03	1
8	6899785	LOCTITE 243 BLUE 6CCM	1
9	15112017000	BUSHING EXTRACTOR	1
10	15112018000	INTERN.BEAR.PULLER 12-16 MM	1
10	15112018100	INTERN.BEAR.PULLER 18-23 MM	1
10	15112018200	INTERN.BEAR.PULLER 5-7 MM	1
11	77029026000	LIMIT PLUG GAUGE F.VALVE GUIDE	1
12	60029043040	SEAL.RING PRESS PUNCH WAT.PUMP	1
13	59029041000	FEEL. GAUGE SET 10,12,15,20,25	1
14	77029041000	INSERT FOR VALVE SPRING LEVER	1
15	59029019000	VALVE SPRING LEVER	1
16	58429037037	MOUNTING TOOL INNER RING NJ206	1
17	59031017200	MIXT. CONTROL SCREW FACTORY 04	1
18	58012009000	FLYWHEEL EXTRACTOR	1
19	309098	SILICON GASKET THREE-BOND	1
20	51012012000	HOLDING SPANNER FOR SPROCKET	1
21	60029073000	SPARK PLUG WRENCH 16MM 1/2INCH	1
26	50329050000	VENT INJEKTION HYDR. CLUTCH	1
27	58429059000	LOCTITE 648 GREEN 24ML	1
28	50329003000	HOLD. PLATE CLUTCH 125/200 '98	1
34	77329034000	WRENCH F.MIXTURE CONTROL SCREW	1
35	77329081000	SP. WRENCH F.HOSE CONNECTOR 07	1
36	77029072000	SPARK PLUG KEY 250 SX-F	1
37*	77029036000	INSERT F. PISTON LOCK RING	1

087702910 / C087702910

* NEW PART

X AS REQUIRED

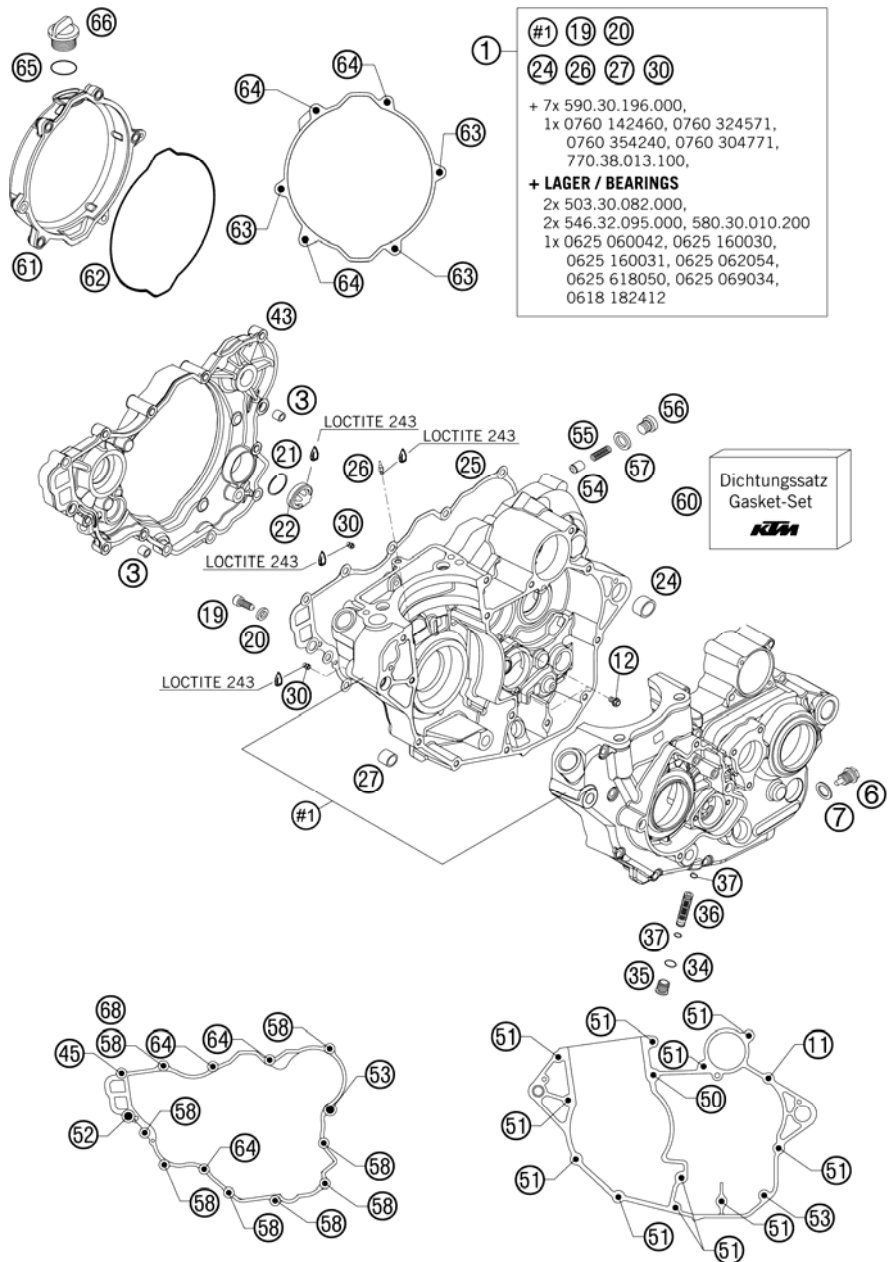

FIG	PART NUMBER	DESCRIPTION	QTY
1	7703000144	ENGINE CASE CPL. 250 SX-F 07	1
3	49030090000	DOWEL 9,8 X 7 X 10	2
6	58030021000	OILDRAIN PLUG W.MAG. M 12X1,5	1
7	58038022000	CU-SEAL RING DIN7603-12X18X1,5	1
11	0015060403	HH COLLAR SCREW M 6X40 WS=8	1
12	0015060083	HH COLLAR SCREW M 6X8 WS=8	2
19	58030080000	LOCATING SCREW M8 L=23	1
20	58030081000	CU-SEAL RING 8 X 14 X 3	1
21	61030019050	CIRCLIP OIL LEVEL GLASS 03	1
22	59030019000	OIL LEVEL GLASS G 1777 Y	1
24	59030024000	DOWEL 17 X 19 X 12	1
25	77030025100	GASKET FOR CLUTCH COVER 05	1
26	60030064070	OIL JET 70 M6X0,75 WS8 03	1
27	54630027000	DOWEL BUSHING 13,8X11X12	1
30	59030058000	JET 100 BING(44-031/180) M4	2
34	0770120020	O-RING 12,00X2,00 NBR 70	1
35	59038014100	PLUG M16X1,5	1
36	59038015000	OIL SCREEN 11,8X44,5MM	1
37	0770090015	O-RING 9X1,5 NBR	2
43*	7703000114425	CLUTCH COVER CPL. GREY	1
45	0015060353	HH COLLAR SCREW M 6X35 WS=8	1
50	0015060653	HH COLLAR SCREW M 6X65 WS=8	1
51	0015060503	HH COLLAR SCREW M 6X50 WS=8	11
52	0015060403	HH COLLAR SCREW M 6X40 WS=8	1
53	0015060303	HH COLLAR SCREW M 6X30 SW=8	2
54	58038028000	VALVE PISTON D=10MM	1
55	58038023300	PRESSURE SPRING L=25MM D=1MM	1
56	0908120153	PLUG DIN0908-M12X1,5	1
57	58038022000	CU-SEAL RING DIN7603-12X18X1,5	1
58	0015060253	HH COLLAR SCREW M 6X25 WS=8	8
60	77030099000	GASKET SET 05	1
61*	7703002620025	CLUTCH COVER OUTSIDE 08	1
62	77030027000	MOLDED RING 05	1
63	0015060253	HH COLLAR SCREW M 6X25 WS=8	3
64	0015060553	HH COLLAR SCREW M 6X55 WS=8	6
65	0770191015	O-RING 19,00X3,00 NBR	1

077703003 / C087703011

* NEW PART

X AS REQUIRED

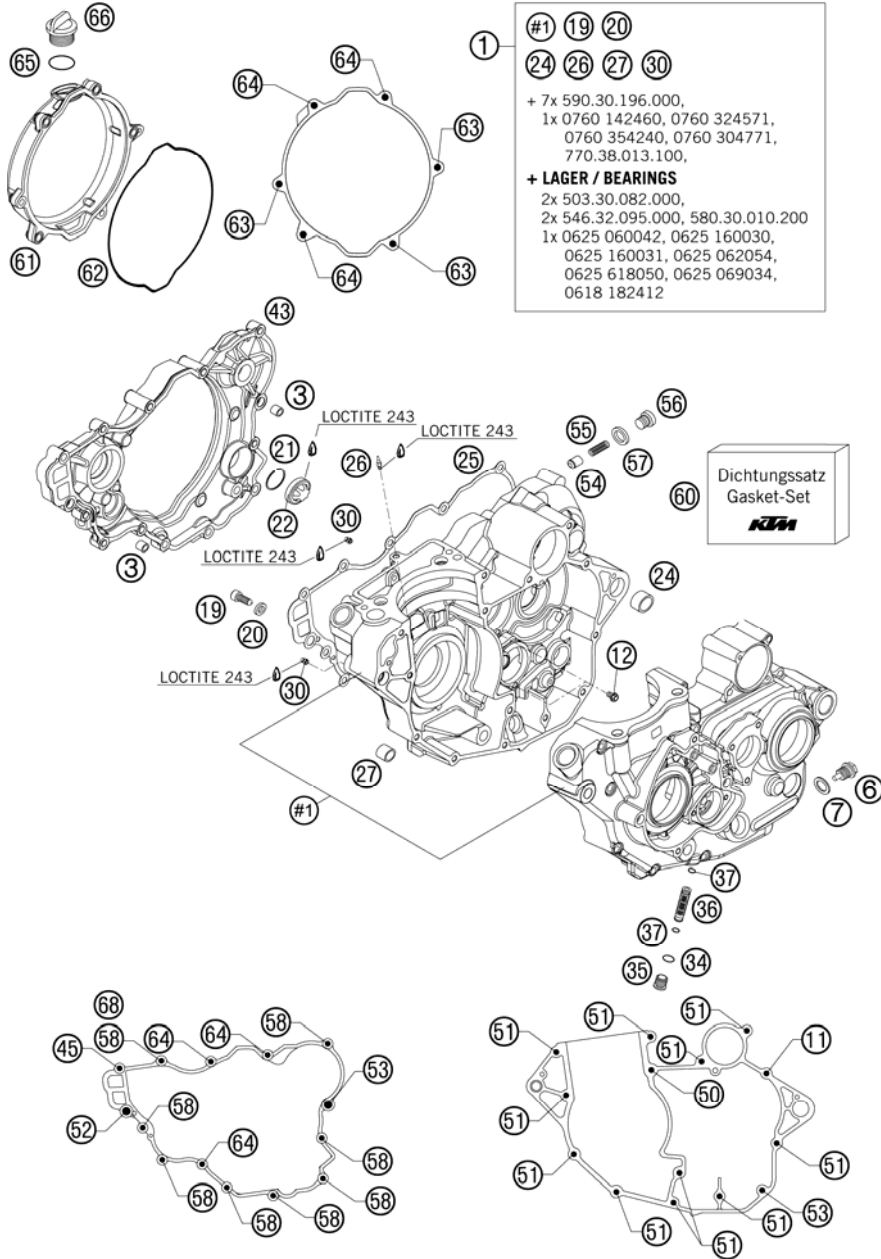

FIG	PART NUMBER	DESCRIPTION	QTY
66	58030020000	PLUG M 24X3	1
68	0603061001	CU-SEAL RING DIN7603-6X10X1	1

077703003 / C087703011

* NEW PART

X AS REQUIRED

CRANKSHAFT, PISTON

250 SXS-F 2008

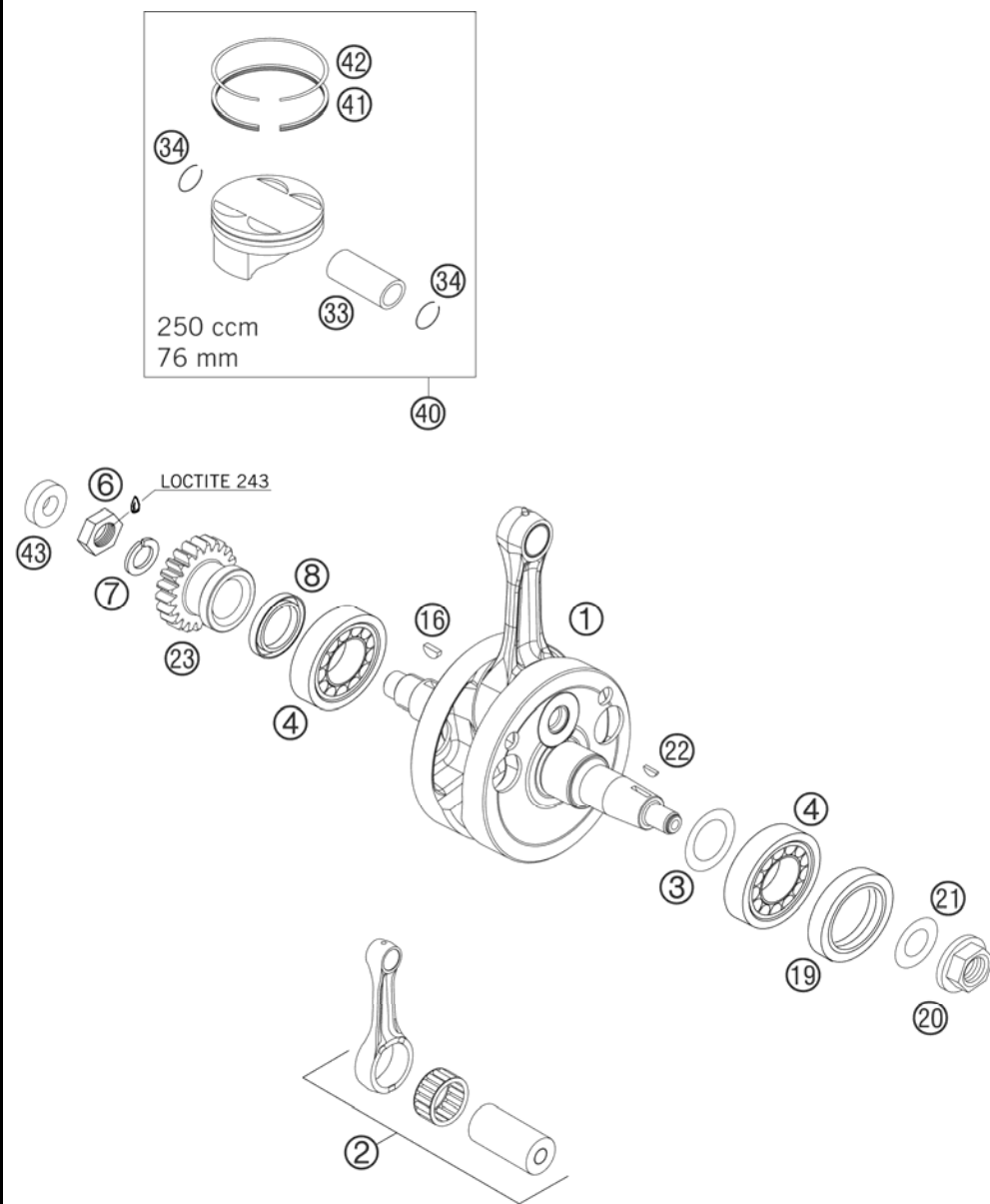

FIG	PART NUMBER	DESCRIPTION	QTY
1*	77030018200	CRANKSHAFT	1
2	77030015144	CON. ROD REP. SET 05	1
3	56030081000	THRUST WASHER 30,5X45X0,10	x
3	56030081100	THRUST WASHER 30,7X47X0,15	x
3	56030081200	THRUST WASHER 30,5X45X0,30	x
4	50330082000	CYL.ROLLER BEAR.NJ206 ET2XCS46	2
6	54630029000	HEX.NUT L/SH M18X1,5	1
7	58132072000	LOCK WASHER VSK 18	1
8	0760354240	SH.SEAL RING 35X42X4 B10FNIB	1
16	6946005	WOODRUFF KEY 5X6,5 HARDED	1
19*	0760304772	SH.SEAL RING 30X47X7 BSL VITON	1
20	49030021000	COLLAR NUT M12X1 R/S	1
21	0137120000	SPRING WASHER DIN0137-B12	1
22	0888030050	WOODRUFF KEY DIN6888-3X5X13	1
23	77032000122	PRIMARY GEAR 22T. 05	x
33	77030033000	PISTON PIN BOLT D=16mm 05	1
34	77030074000	CIRCLIP 05	1
40	77030007500 I	PISTON I CPL.	1
40	77030007500 II	PISTON II CPL.	1
41	77030032200	OIL SCRAPER RING	1
42	77030030100	COMPRESSIONRING D=76	1
43	0760142460	SHAFT SEAL RING 14X24X6 B	1

087703060 / C087703061

* NEW PART

X AS REQUIRED

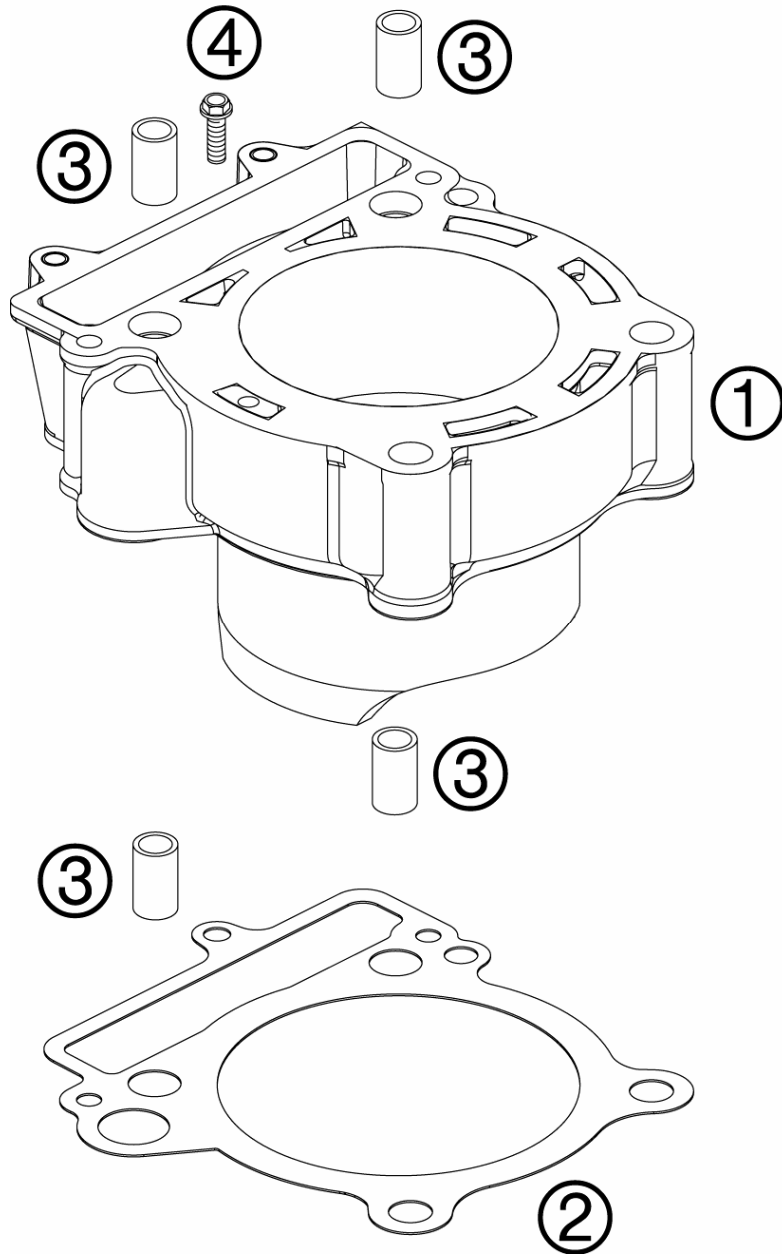

FIG	PART NUMBER	DESCRIPTION	QTY
1	77030005100	CYLINDER 2009	1
2	77030035100	CYLINDER BASE GASKET 07	1
3	58530014000	DOWEL 10,2X12,5X10 2001	4
4	0015060253	HH COLLAR SCREW M 6X25 WS=8	1

087703040 / C08SXS3040

* NEW PART

X AS REQUIRED

CARBURETOR

250 SXS-F 2008

ACHTUNG !!!
Vor dem Einbau des Vergasers,
Bedüsung kontrollieren.



CAUTION !!!
Before mounting the carburetor,
check the jetting.

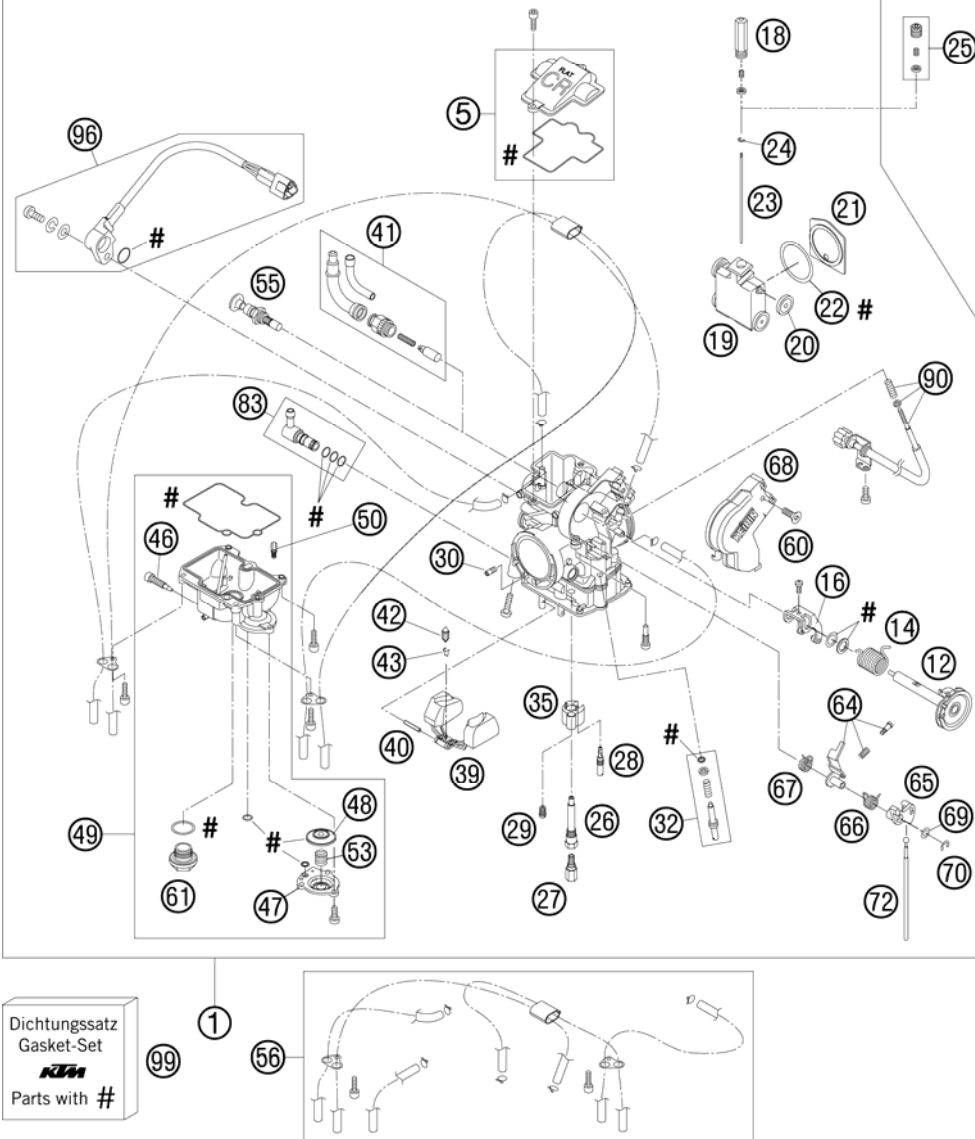

FIG	PART NUMBER	DESCRIPTION	QTY
1*	77031001400	CARBURETOR FCR-MX 3925F,TPS 08	1
5	57331027044	CARBURETOR COVER WITH GASKET	1
12	57331046100	THROTTLE SHAFT CPL. 06	1
14	57331046050	COIL SPRING THROTTLE SHAFT	1
16*	76231035051	LINK ARM THROTTLE VALVE CPL.07	1
18	59031029010	SLIDE STOP 03	1
19*	57331035100	THROTTLE VALVE CPL. FCRMX 2007	1
20	59031035050	BUSHING THROTTLE VALVE	4
21	57331035153	GASKET PLATE THROTTLE VALVE 04	1
22	59031035052	GASKET WASHER THROTTLE VALVE	1
23	57331034500	JET NEEDLE KEIHIN OBEKT	x
23	59031034100	JET NEEDLE KEIHIN OBETP	x
23	59031034200	JET NEEDLE KEIHIN OBETN	x
23	59031034300	JET NEEDLE KEIHIN OBETQ	x
24	59031029000	BAR CLIP	1
25	57331032000	NEEDLE SET SCREW CPL.	1
26	59031121000	NEEDLE JET FCR-MX	1
27	54531623162	MAIN JET 162 KEIHIN	x
27	54531623165	MAIN JET 165 KEIHIN	x
27	54531623168	MAIN JET 168 KEIHIN	x
27	54531623170	MAIN JET 170 KEIHIN	x
27	54531623172	MAIN JET 172 KEIHIN	x
27	54531623175	MAIN JET 175 KEIHIN	x
27	54531623178	MAIN JET 178 KEIHIN	x
27	54531623180	MAIN JET 180 KEIHIN	x
28	54531607038	IDLE JET 38 KEIHIN	x
28	54531607040	IDLE JET 40 KEIHIN	x
28	54531607042	IDLE JET 42 KEIHIN	x
29	59031051085	STARTER JET 85	x
30	57331107100	IDLE AIR JET 100 KEIHIN	1
32	59031017100	ADJUST SCREW CPL. FCR-MX	1
35	57331085000	BUFFER PLATE	1
39	57331009000	FLOAT CPL.	1
40	57331008000	ARM PIN FLOAT	1
41	77031075000	HOT-STARTER VALVE	1
42	54631220000	FLOAT NEEDLE	1

08SXS3110 / C08SXS3110

* NEW PART

X AS REQUIRED

CARBURETOR

250 SXS-F 2008

ACHTUNG !!!
Vor dem Einbau des Vergasers,
Bedüsung kontrollieren.



CAUTION !!!
Before mounting the carburetor,
check the jetting.

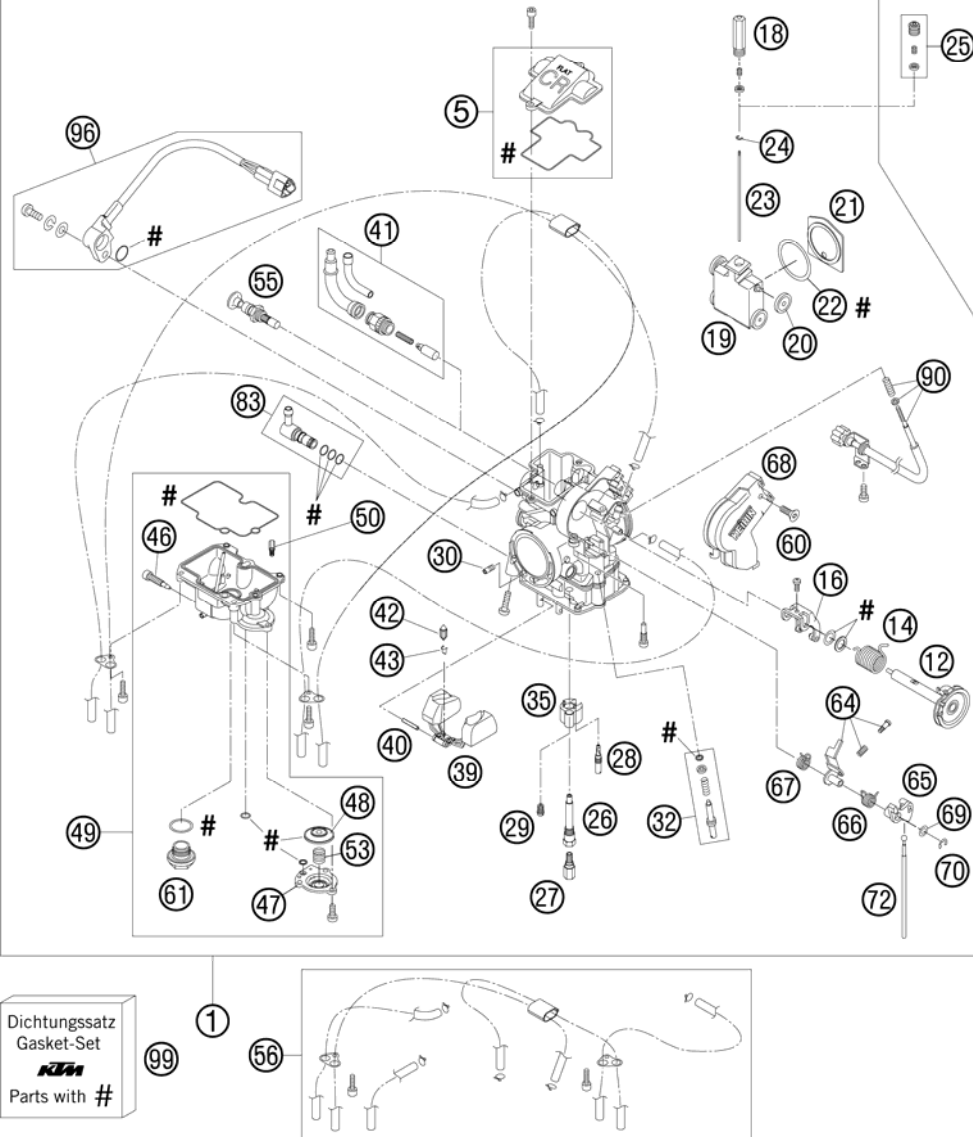

FIG	PART NUMBER	DESCRIPTION	QTY
43	54531621000	CLAMP	1
46*	76231155000	DRAIN SCREW FLOAT CHAMBER	1
47	57331060000	COVER ACCELERATOR PUMP	1
48	57331057100	DIAPHRAGM ACCELERATOR PUMP	1
49*	78031011000	FLOAT CHAMBER CPL. 08	1
50	54631085000	JET POWER JET CLOSED KEIHIN	x
50	54631085050	JET POWER JET 50 KEIHIN	x
50	54631085060	JET POWER JET 60 KEIHIN	x
50	54631085070	JET POWER JET 70 KEIHIN	x
53*	SXS08250030	SXS COIL SPRING THROTTLE SHAFT	1
55	77031048000	STARTER VALVE SHORT CPL.	1
56	57331098000	BREATH.HOSE FCR-MX KEIHIN CPL.	1
60	0965050103	FLAT HEAD SCREW DIN0965-M 5X10	1
61	54531699000	PLUG M 18X1	1
64	57331062000	INTERMEDIATE LEVER CPL.	1
65	57331056000	LINK LEVER	1
66	57331059000	SPRING LINK LEVER	1
67	57331159000	SPRING INTERMEDIATE LEVER	1
68	57331038200	CARBURETOR COVER 06	1
69	57331087000	WASHER LINK LEVER	1
70	57331084000	E-CLIP	1
72	57331061000	ROD ACCELERATOR PUMP	1
83	59031013044	HOSE CONNECTOR CPL.	1
90	57331025000	STOP SCREW CPL. FCR-MX	1
96	59031077200	TPS-SENSOR FCRMX 190MM 2006	1
99	57331099000	GASKET SET FCR-MX KEIHIN	1

08SXS3110 / C08SXS3110

* NEW PART

X AS REQUIRED

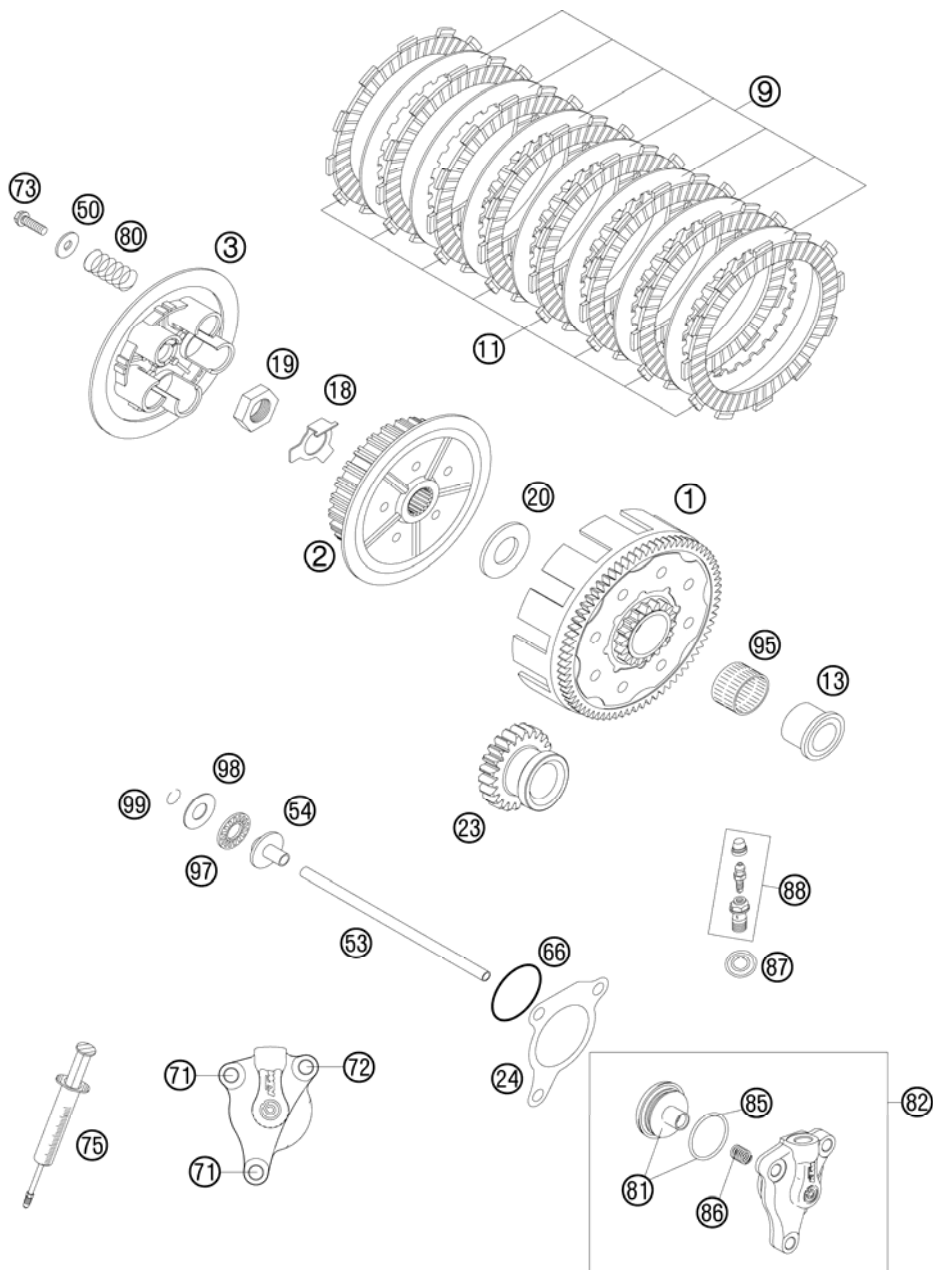

FIG	PART NUMBER	DESCRIPTION	QTY
1*	77032001100	OUTER CLUTCH CPL.	1
2	77032002000	INNER CLUTCH HUB	1
3	77032003000	PRESSURE PLATE	1
9	77032010000	INTERMEDI. DISC STEEL	7
11	77032011000	LINING DISC 3,0MM	8
13	50332013000	INNER RING 20X26X25,9	1
18	50332018000	SHEET METAL LOCK 1,5MM	1
19	0936181505	HEXAGON NUT DIN0936-M18X1,5 R.	1
20	50332020000	STOP DISK 20X39,6X3	1
23	77032000122	PRIMARY GEAR 22T.	1
24	59032065000	GASKET FOR SLAVE CYLINDER	1
50	50232050000	WASHER 6,2X18X2	5
53	77032054000	PUSH ROD	1
54	50332054051	PRESSURE PIECE 125-380	1
66	0770300015	O-RING 30,00X1,50 NBR 70	1
71	0015060203	HH COLLAR SCREW M 6X20 WS=8	2
72	0015060353	HH COLLAR SCREW M 6X35 WS=8	1
73	0015060253	HH COLLAR SCREW M 6X25 WS=8	5
75	50329050000	VENT INJEKTION HYDR. CLUTCH	1
80	77032005000	CLUTCH SPRING	5
81	54832066000	PISTON CPL.	1
82	54832061044	OUTPUT CYLINDER CPL.	1
85	54832067000	O-RING	1
86	54832069000	PRESSURE SPRING	1
87	42013226000	CU-SEAL RING DIN7603-10X16X1	1
88	54813020000	BLEEDER HOLLOW SCREW M10X1	1
95	56532095000	NEEDLE BEARING K26X30X22ZW.KSE	1
97	54637097200	AXIAL NEEDLE BEARING AXK 1226	1
98	54637098200	AXIAL WASHER AS1226 12X26X1	1
99	0993012000	CIRCLIP DIN7993-RW12	1

08SXS3211 / C08SXS3211

* NEW PART

X AS REQUIRED

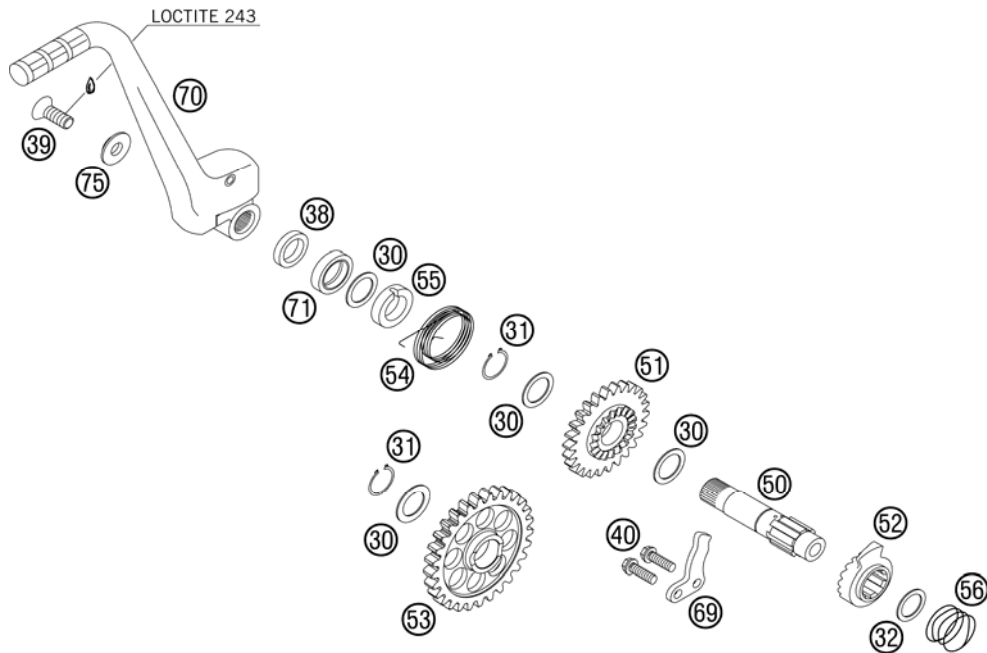

FIG	PART NUMBER	DESCRIPTION	QTY
30	50333030000	STOP DISK 17,2X24X1	4
31	0471170010	CIRCLIP DIN0471-17X1	2
32	0988162210	THRUST WASHER DIN0988-16X22X1	1
38	50333038100	SPACER BUSHING 16X23X26X6,1	1
39	54610052000	SPROCKET SCREW-AH M8X20 WS=6	1
40	0015060163	HH COLLAR SCREW M 6X16 WS=8	2
50	77033050000	KICKSTARTER SHAFT 05	1
51	77033051000	KICKSTART. GEAR 28-T 05	1
52	50333052000	KICKSTARTER RATCHET	1
53	77033053000	INTERMEDIATE GEAR 05	1
54	77033054000	KICKSTARTER SPRING 05	1
55	77033055000	DRIVING HUB 05	1
56	50333056000	SPRING 1,4MM '98	1
69	50333069000	STOP MET.SHEET 4MM 125/200'98	1
70	77033070044	KICKSTARTER CPL. 07	1
71	0760172870	SHAFT SEAL RING 17X28X7 B	1
75	54633037000	WASHER 8MM GALVANIZED	1

057703303 / C087703390

* NEW PART

X AS REQUIRED

TRANSMISSION I

250 SXS-F 2008

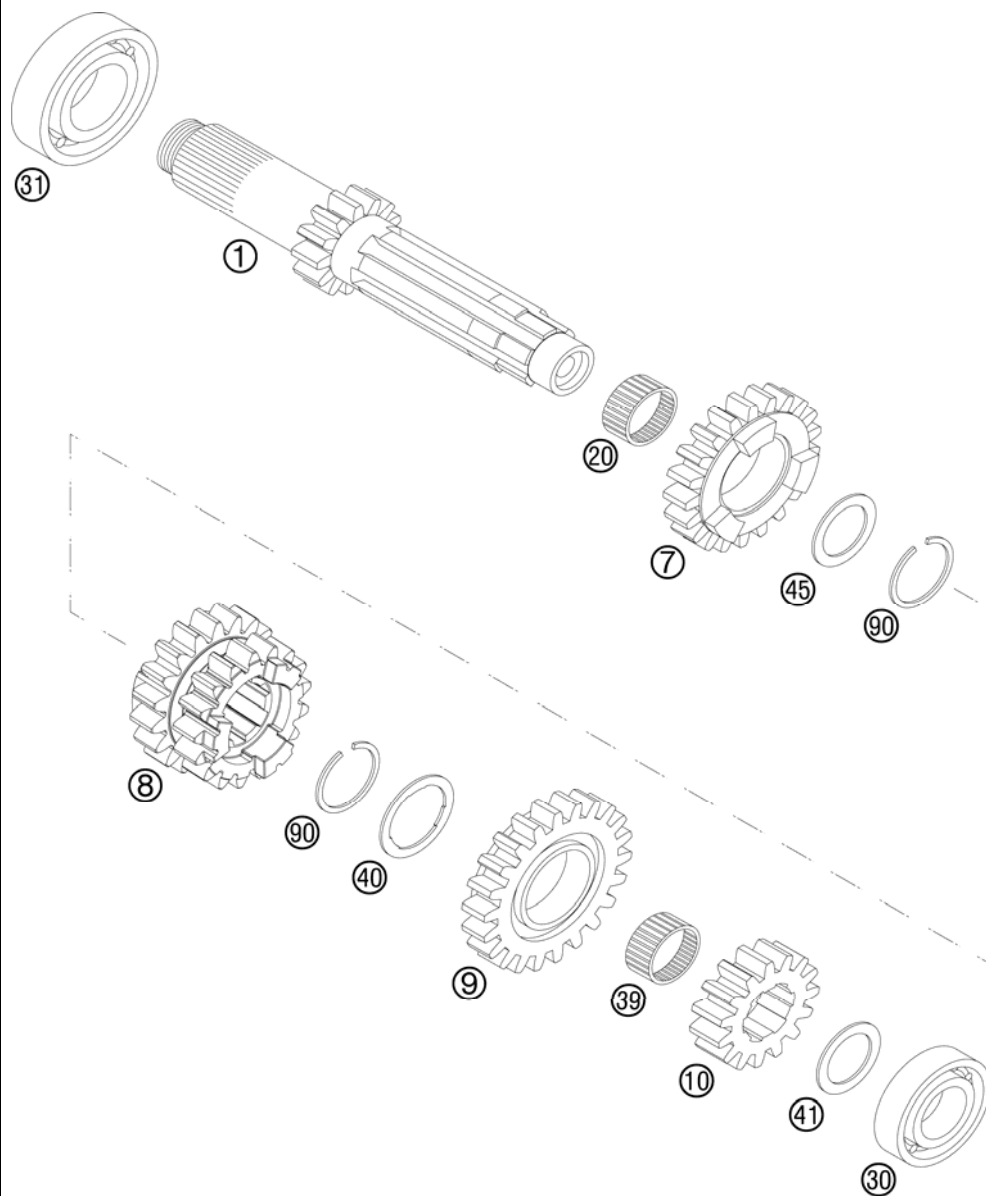

FIG	PART NUMBER	DESCRIPTION	QTY
1	77033001000	MAIN SHAFT CPL. T=13 05	1
7	77033005000	IDLER G.5TH G.21-T 06	1
8*	SXS08250150	SLIDING GEAR 3/4 GEAR	1
9	77033006000	IDLER G.6TH G.22-T 06	1
10	77033002000	SOLID GEAR 2ND G.15-T 05	1
20	0405222611	NEEDLE BEAR.K 22X26X10 DIVIDED	1
30	0625160032	GROOVED BALL BEARING 16003 Z	1
31	0625060042	BALL BEARING 6004 TN9 C4	1
39	50133099000	NEEDLE CAGE K18X22X10 PARTED	1
40	77033021000	STOP DISC 05	1
41	50333030000	STOP DISK 17,2X24X1	1
45	77033020000	STOP GEAR 22X28.5X1 05	1
90	50133090000	LOCK RING 22X1,2	2

08SXS3330 / C08SXS3330

* NEW PART

X AS REQUIRED

TRANSMISSION II

250 SXS-F 2008

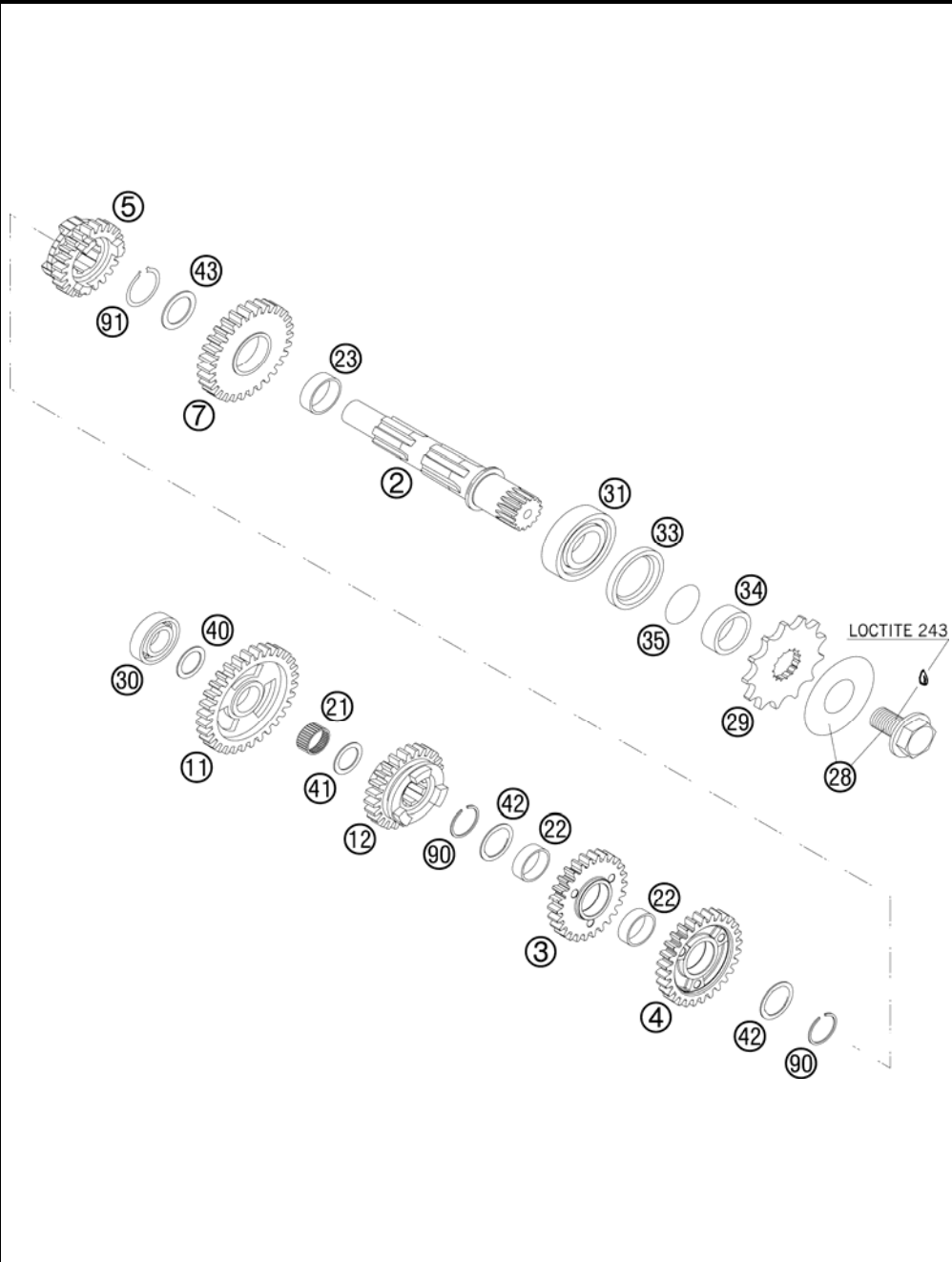

FIG	PART NUMBER	DESCRIPTION	QTY
2	77033010000	COUNTER SHAFT	05
3	77033014000	IDLER G. 4TH G.26-T	06
4*	SXS08250151	IDLER G. 3RD G.	1
5	77033016200	SLIDING G. 6TH G.24-T	1
7	77033012000	IDLER G. 2ND G. 30-T	06
11	77033011000	IDLER G. 1ST G. 32-T	06
12*	77033015200	SLIDING G. 5TH G.25-T	08
21	50033098000	NEEDLE BEARING K20X24X10	1
22	0405222611	NEEDLE BEAR.K 22X26X10 DIVIDED	2
23	50333023000	IDLER GEAR BUSHING 25X28X9,7 D	1
28	59033034044	SCREW+SPRING WASHER	1
29	50033029013	SPROCKET 13-T	x
29	50033029014	SPROCKET 14-T	x
29	50033029015	SPROCKET 15-T	x
30	0625060031	BALL BEARING 6003 TN9 C4	1
31	0625062054	BALL BEARING 6205 C3 NTN	1
33	0760324571	SHAFT SEAL RING 32X45X7 BSLNBR	1
34	54633014100	SPACER BUSHING 12MM	1
35	0770020220	O-RING 25,12X1,78 NBR70	1
40	56033030000	STOP DISC 17,2X30X1	1
41	59033080000	SHIM 20X32X1	1
42	50333043000	STOP DISC 25,2X32X1	2
43	0988253510	THRUST WASH. DIN0988-25X35X1,0	1
90	77033022000	AXIAL-CIRCLIP 25X1,65	2
91	0471250120	CIRCLIP DIN0471-25X1,2	1

08SXS3360 / C08SXS3360

* NEW PART

X AS REQUIRED



SHIFTING MECHANISM

250 SXS-F 2008

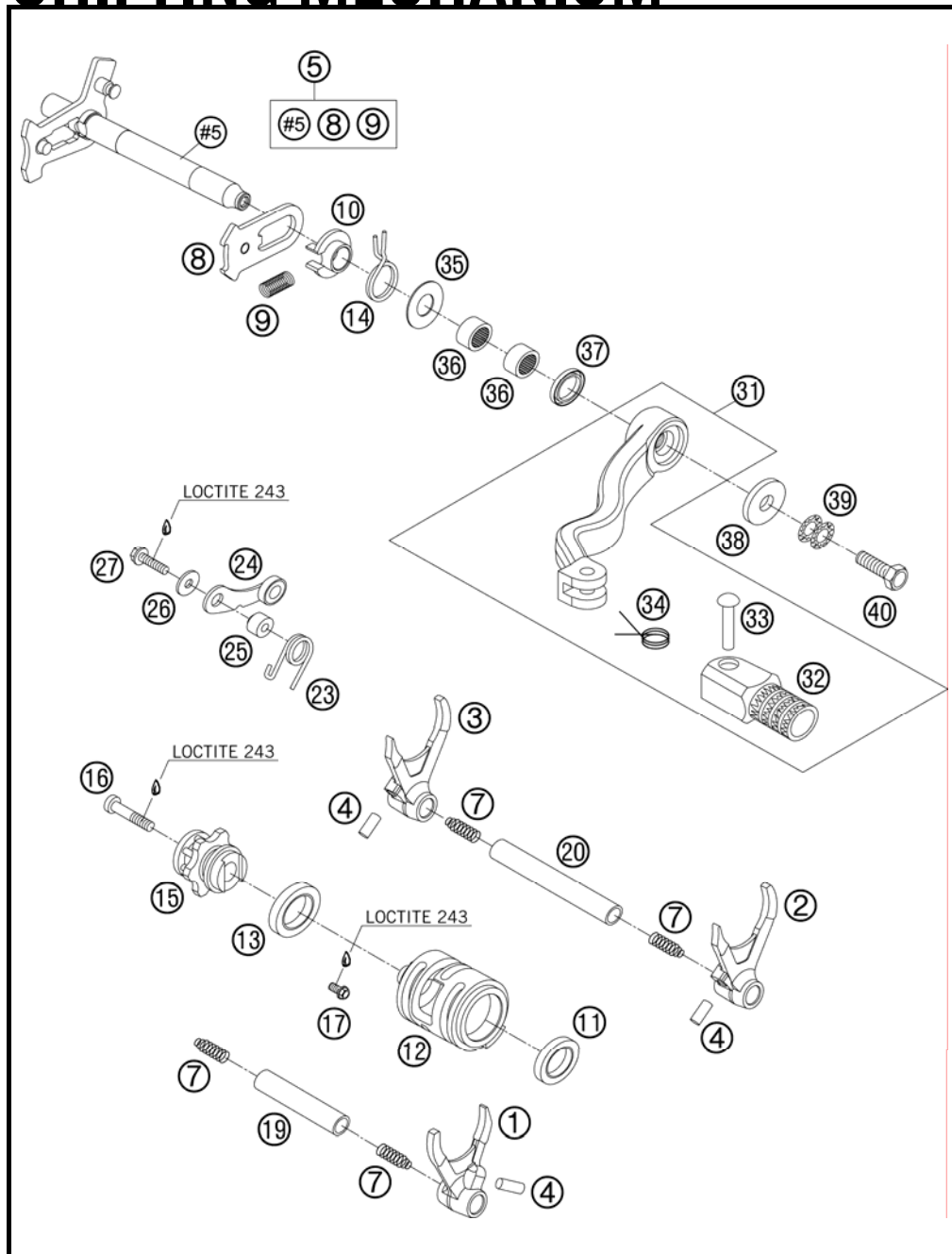

FIG	PART NUMBER	DESCRIPTION	QTY
1	77034001000	SHIFTING FORK 5TH/6TH GEAR 05	1
2	77034002000	SHIFTING FORK 2ND/3RD GEAR 05	1
3	77034003000	SHIFTING FORK 1ST/4TH GEAR 05	1
4	0402061480	NEEDLE ROLLER DIN5402 6X14,8	3
5	77034005044	SHIFTING SHAFT CPL. 05	1
7	58038023200	PRESSURE SPRING 0,9MM	4
8	54634008044	SLIDING PLATE CPL.	1
9	56534013100	TENSIONING SPRING 0,8MM	1
10	54634020000	SPRING GUIDE	1
11	0625069034	BALL BEARING 6903 C4	1
12	77034012000	SHIFT ROLLER 05	1
13	0625618050	BALL BEARING 61805 C3	1
14	54634014100	RETURN SPRING 2,2MM '95	1
15	77034015144	SHIFTING SHAFT CPL. 05	1
16	0984060302	AH SCREW DIN6912 M 6X30	1
17	0015060083	HH COLLAR SCREW M 6X8 WS=8	1
19	54834019000	SHIFT. RAIL MAIN SHAFT 250/300	1
20	77034019000	SHIFTING MAIN L=93MM 05	1
23*	77034023000	LOCKING LEVER SPRING	1
24	77034024044	LOCKING LEVER CPL. 08	1
25	54634052300	SLEEVE FOR LOCKING LEVER	1
26	0349000050	WASHER DIN7349-5X15X2	1
27	0015050203	HH COLLAR SCREW M 5X20 WS=8	1
31	54834031000	SHIFT LEVER CPL. 250/300 05	1
32	54634131000	STEP PLATE FOR SHIFT LEVER 250	1
33	54634031050	BOLT 6X25 FOR SHIFT LEVER	1
34	54634032100	SHIFTING LEVER SPRING 250	1
35	54634050000	STOP DISK 14X30X1	1
36	54632095000	NEEDLE BEAR.HK 1412 14X20X12	2
37	0760142460	SHAFT SEAL RING 14X24X6 B	1
38	50232050001	STEEL WASHER 6,4X17X3	1
39	50233041000	PAIR OF WASHERS M 6 NORDLOCK	1
40	59009062016	SPECIAL SCREW M6X16 WS=8 10.9	1

077703401 / C087703410

* NEW PART

X AS REQUIRED

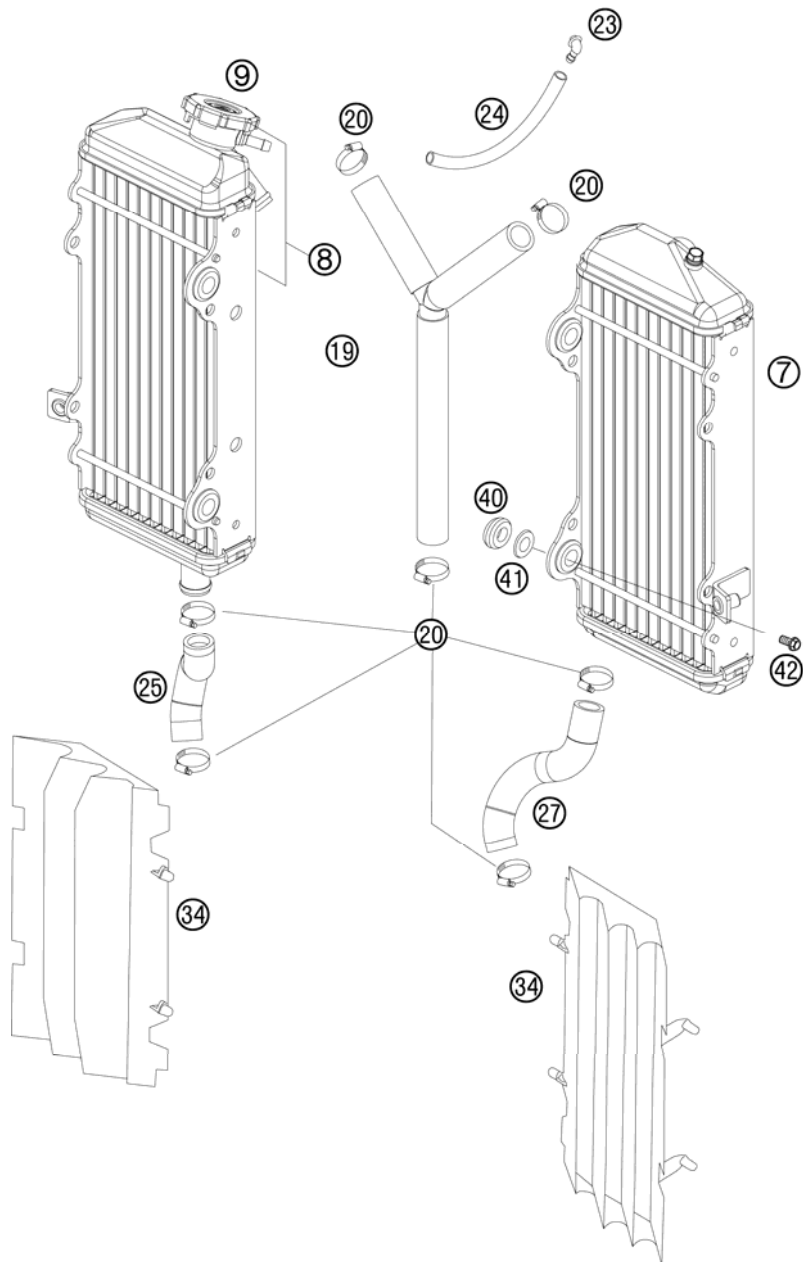
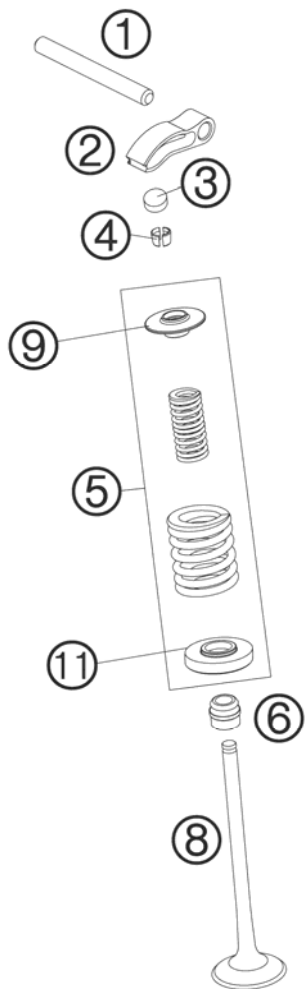

FIG	PART NUMBER	DESCRIPTION	QTY	
7*	SXS08254600	RADIATOR L/S 'VW 1584'	08	1
8*	SXS08450601	RADIATOR R/S 'VW 1643'	08	1
9	77335016000	RADIATOR CAP SMALL 1,8 BAR		1
19*	SXS08254610	RADIATOR HOSE CPL.	08	1
20	10001020000	HOSE CLAMP GEMI 16-27		7
23	50303089000	ANGEL PIECE '97		1
24	31007107001	PVC-HOSE 6X9 MM PER METER		x
25*	SXS08254611	RADIATOR HOSE R/S	08	1
27*	SXS08254612	RADIATOR HOSE L/S	08	1
34*	5903504000030	RADIAT. PROTECT. RAC. BLACK 06		2
40	41001052000	RUBBER SLEEVE D=12MM		4
41*	77335001000	WASHER		4
42*	0023060123	COLLAR SCREW M6X12 TX		4

08SXS3531 / C08SXS3531

* NEW PART

X AS REQUIRED



EXHAUST

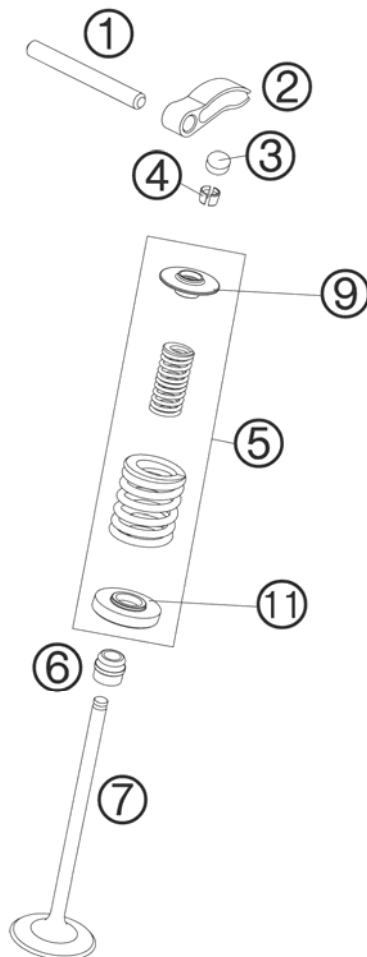

INTAKE

FIG	PART NUMBER	DESCRIPTION		QTY
1	77036056000	VALVE LEVER SHAFT		2
2	77036060000	VALVE LEVER	05	4
3	77036035172	SHIM D=8,9/1,72		x
3	77036035176	SHIM D=8,9/1,76		x
3	77036035180	SHIM D=8,9/1,80		x
3	77036035184	SHIM D=8,9/1,84		x
3	77036035188	SHIM D=8,9/1,88		x
3	77036035192	SHIM D=8,9/1,92		x
3	77036035196	SHIM D=8,9/1,96		x
3	77036035200	SHIM D=8,9/2,00		x
3	77036035204	SHIM D=8,9/2,04		x
3	77036035208	SHIM D=8,9/2,08		x
3	77036035212	SHIM D=8,9/2,12		x
3	77036035216	SHIM D=8,9/2,16		x
3	77036035220	SHIM D=8,9/2,20		x
3	77036035224	SHIM D=8,9/2,24		x
3	77036035228	SHIM D=8,9/2,28		x
3	77036035232	SHIM D=8,9/2,32		x
3	77036035236	SHIM D=8,9/2,36		x
3	77036035240	SHIM D=8,9/2,40		x
3	77036035244	SHIM D=8,9/2,44		x
3	77036035248	SHIM D=8,9/2,48		x
3	77036035252	SHIM D=8,9/2,52		x
3	77036035256	SHIM D=8,9/2,56		x
3	77036035260	SHIM D=8,9/2,60		x
4	77036033000	VALVE COLLET	05	8
5	77036028144	VALVE SPRING KIT		4
6	77036027000	VALVE-STEM SEALING	05	4
7	77036030000	INTAKE VALVE TITAN	05	2
8	77036031000	EXHAUST VALVE TITAN	05	2
9	77036032400	VALVE SPRING RETAINER		x
11	77036036100	VALVE SPRING HOLDER	05	x

08SXS3610 / C08SXS3610

* NEW PART

X AS REQUIRED

TIMING VALVE

250 SXS-F 2008

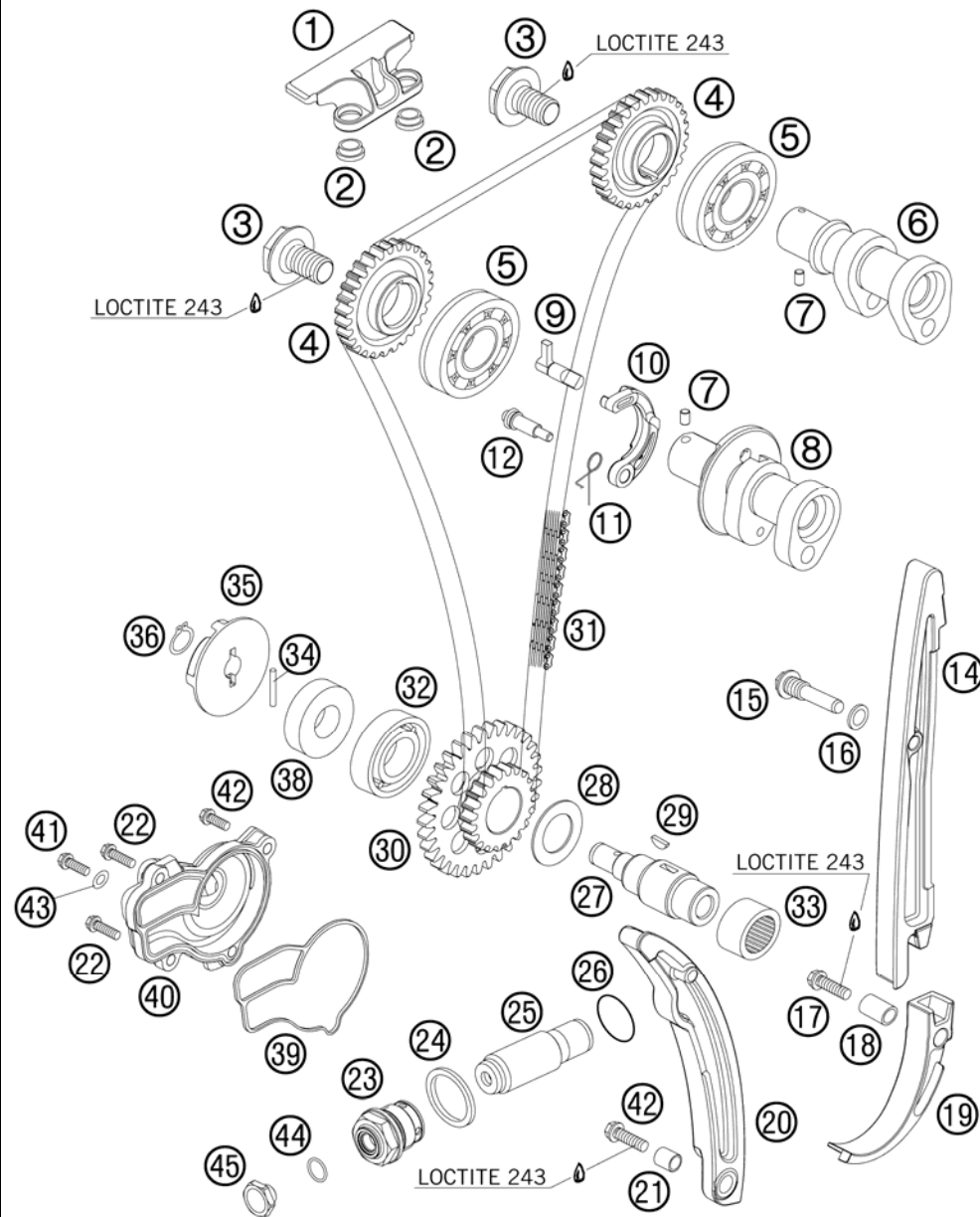

FIG	PART NUMBER	DESCRIPTION	QTY
1	77036004000	TIMING CHAIN GUIDE TOP 05	1
2	77036004050	SPACER BUSHING GUIDE RAIL 05	2
3*	77036012100	CAMSHAFT GEAR SCREW 08	2
4	77036011100	CAMSHAFT GEAR 05	2
5	0625060043	BALL BEARING 6004 NR C3 05	2
6	77036009200	CAMSHAFT INTAKE 2007	1
7	0402040600	NEEDLE ROLLER DIN5402 NRB 4X6	2
8	77036010100	CAMSHAFT EXHAUST 2006	1
9*	77036015100	AUTO DECOMPRESSION	1
10*	77036016100	AUTO DECO WEIGHT	1
11	77036017000	SPRING FOR AUTO DECOMPR. 05	1
12	77036019000	BUSHING SCREW AUTODEC. M5X0,8	1
14	77036001000	TIMING CHAIN GUIDE 05	1
15*	77036001160	BUSHING SCREW 06	1
16	0603082121	SEAL RING CU DIN7603- 8X12X1	1
17	0015060253	HH COLLAR SCREW M 6X25 WS=8	1
18	59036001050	SPACER BUSHING 6,1X8,2X13,1	1
19	77036005000	SECURING PROTECTION 05	1
20	77036002000	TIMING CHAIN TENSIONER 05	1
21	77036001050	SPACER BUSHING 6.1X8.2X9.1 05	1
22	0015060403	HH COLLAR SCREW M 6X40 WS=8	2
23*	78036008000	CHAIN ADJUSTER HOLDING BOLT	1
24	0603242920	CU SEAL-RING DIN7603 A24X29X2	1
25	77036003000	CHAIN ADJUSTER HYD. 05	1
26	0770180020	O-RING 18,00X2,00 NBR 70	1
27*	77036072100	TIMING VALVE JACKSHAFT 08	1
28	77036073000	STOP DISK 18,2X30X1 05	1
29	0888030037	WOODRUFF KEY DIN6888-3X3,7	1
30	77036076100	TIMING VALVE TWIN WHEEL 05	1
31	77036013000	TIMING CHAIN IWIS 108 ROLLS	1
32	0625062035	BALL BEARING 6203 JR2 C3	1
33	0618182412	NEEDLE BEAR.HK1812 18/24/12 05	1
34	0402031780	NEEDLE ROL.DIN5402 NRB 3X17,8	1
35	77035055000	WATER PUMP ROTOR 05	1
36	0471100010	CIRCLIP DIN0471-10X1	1
38	0760123073	SHAFT SEAL RING 12X30X7 PTFE	1

087703620 / C08SXS3621

* NEW PART

X AS REQUIRED

TIMING VALVE

250 SXS-F 2008

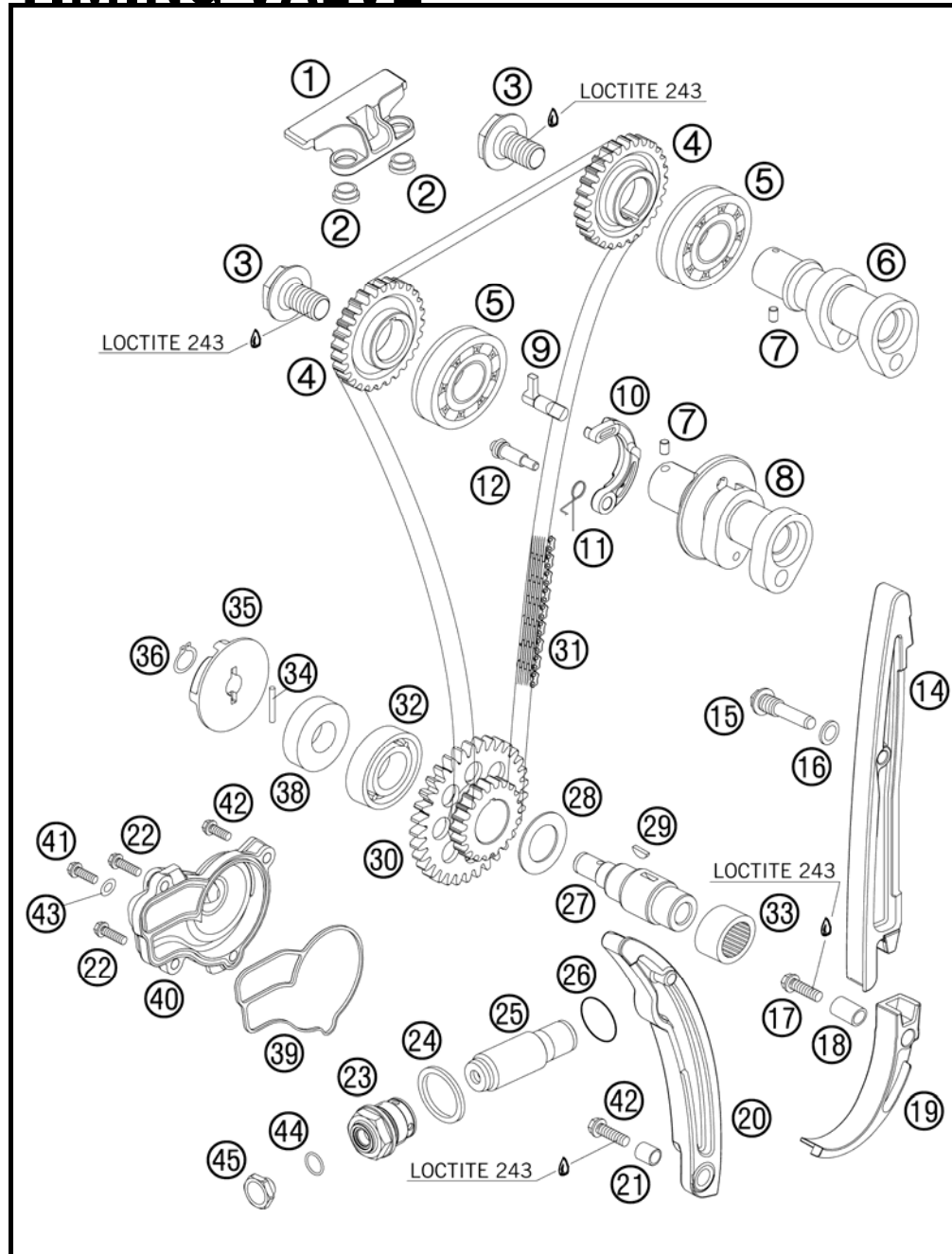

FIG	PART NUMBER	DESCRIPTION	QTY
39	77035053000	MOLDED RING WATER PUMP 05	1
40	77035052000	WATER PUMP COVER 05	1
41	0015060303	HH COLLAR SCREW M 6X30 SW=8	1
42	0015060203	HH COLLAR SCREW M 6X20 WS=8	2
43	0603061001	CU-SEAL RING DIN7603-6X10X1	1
44*	0770010010	O-RING 10,00X1,00 NBR 70 SH	1
45*	77336008010	HOLDING BOLT	1

087703620 / C08SXS3621

* NEW PART

X AS REQUIRED



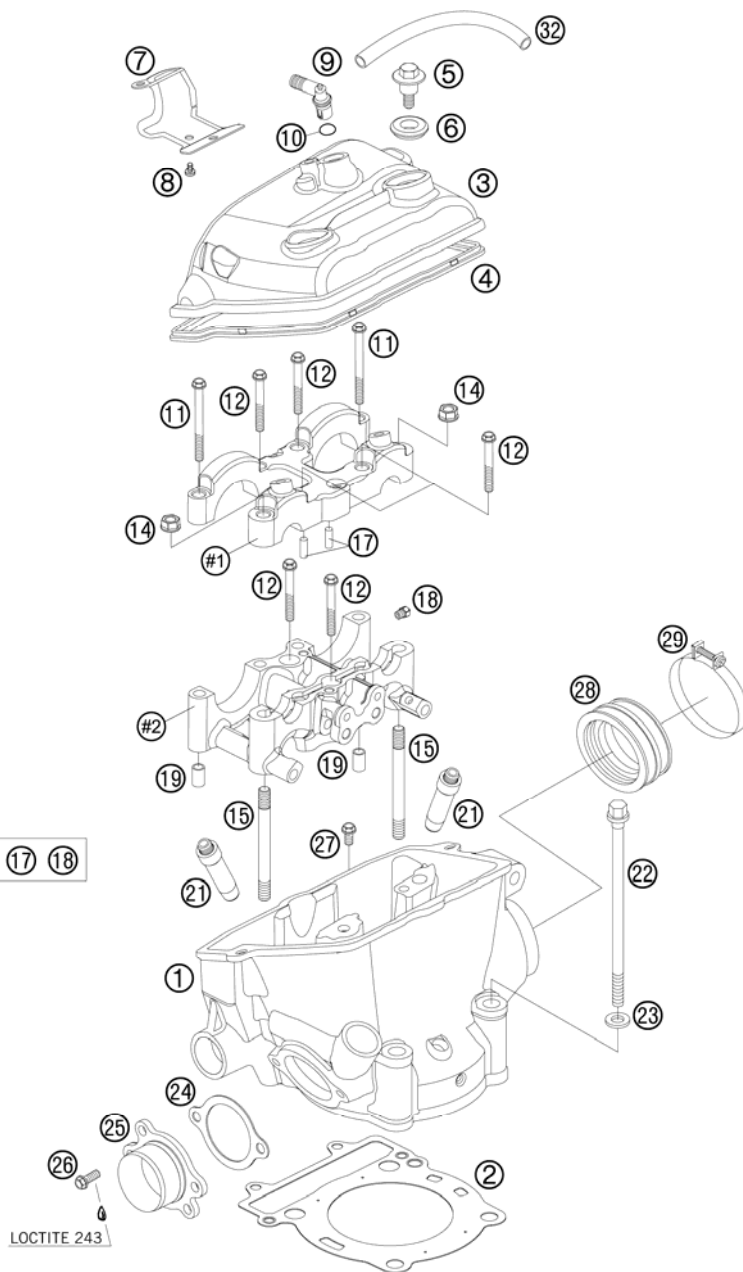

FIG	PART NUMBER	DESCRIPTION	QTY
1*	SXS08250003	CYLINDER HEAD	1
2	77030036000	CYLINDER HEAD GASKET 05	1
3	77036052100	VALVE COVER 06	1
4	77036053000	VALVE COVER GASKET 05	1
5	77036055100	VALVE COVER SCR. M6X12 WS10 07	3
6	77036054050	RUBBER GASKET FOR SCREW 05	3
7	77036052050	COVER PLATE BREATHER 05	1
8	0009050103	SPECIAL SCREW M 5,0X10	2
9	60038082000	ANGLE CONNECTOR LC8 03	1
10	0770080020	O-RING 8X2 SILICONE	1
11	77036081000	SPECIAL SCREW M7X73 WS 10	2
12	77036080000	SPECIAL SCREW M7X40 WS10	6
14	77036024000	COLLAR NUT 7X1 05	2
15	77036023000	STUD 7X1 05	2
16	77036020150	BUSH SUPPORT A.BRIDGE CPL '05	1
17	0402050980	NEEDLE ROLLER DIN5402 5X9,8	2
18	60030063050	OIL JET 50 05	4
19	77036090000	DOWEL(BUSH BRIDGE)7/9/8 05	2
21	77036026001	VALVE GUIDE OUTLET	4
22	77036079000	CYLINDER HEAD SCREW 05	4
23	59036090000	WASHER 10,8X18,8X1,5	4
24	77036041000	GASKET EXHAUST FLANGE 06	1
25	SXS06250506	EXHAUST FLANGE CPL. 06	1
26	0015060203	HH COLLAR SCREW M 6X20 WS=8	2
27	0015060253	HH COLLAR SCREW M 6X25 WS=8	2
28	77036044000	INTAKE BOOT 06	1
29	59030061000	CLAMP D=56MM B=9MM M4X25	1
32	59031050100	ENGINE BREATHER TUBE 00	1

08SXS3631 / C08SXS3631

* NEW PART

X AS REQUIRED

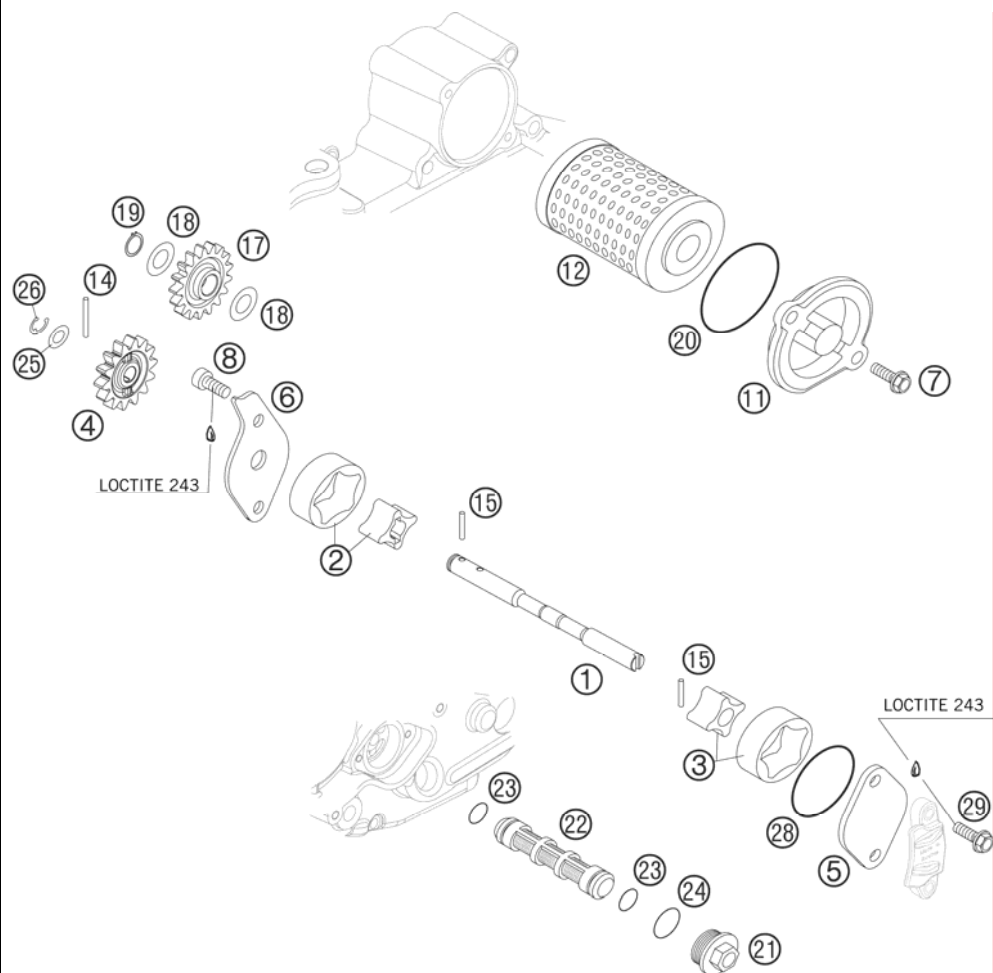

FIG	PART NUMBER	DESCRIPTION	QTY
1	77038102000	OIL PUMP SHAFT EXC-F	1
2	59038011010	OILPUMP ROTOR CPL. 10MM G-73R	1
3	77038011000	OILPUMP ROTOR 15MM G-164	1
4*	77038001100	OIL PUMP GEAR 14T 08	1
5	77038004000	OIL PUMP COVER L/S 05	1
6	77038003100	OIL PUMP COVER R/S 05	1
7	0015050163	HH COLLAR SCREW M 5X16 WS=8	2
8	0984050122	AH SCREW DIN6912-M 5X12	2
11	59038041000	OIL FILTER COVER RACING	1
12	77038005000	OIL FILTER 06	1
14	0402251980	NEEDLEROL.DIN5402 NRA 2,5X19,8	1
15	0402251180	NEEDLE ROLLER DIN5402 2,5X11,8	2
17*	77038006100	OILPUMP IDLER GEAR 08	1
18	0988121805	SHIM WASHER DIN0988-12X18X0,50	2
19	0471120010	CIRCLIP DIN0471-12X1	1
20	0770400025	O-RING 40,00X2,50 NBR 70	1
21	59038017000	PLUG M20X1,5 WS=13	1
22	59038016000	OIL SCREEN 15X83MM	1
23	0770125015	O-RING 12,5X1,5 NBR	2
24	0770020170	O-RING 17,17X1,78 GLO	1
25	58038007755	STOP DISK 8,1 X 15 X 0,5	1
26	0799060000	TAB WASHER DIN6799-RS 6,0	1
28	0770320020	O-RING 32,00X2,00	1
29	0015050203	HH COLLAR SCREW M 5X20 WS=8	2

087703810 / C087703810

* NEW PART

X AS REQUIRED

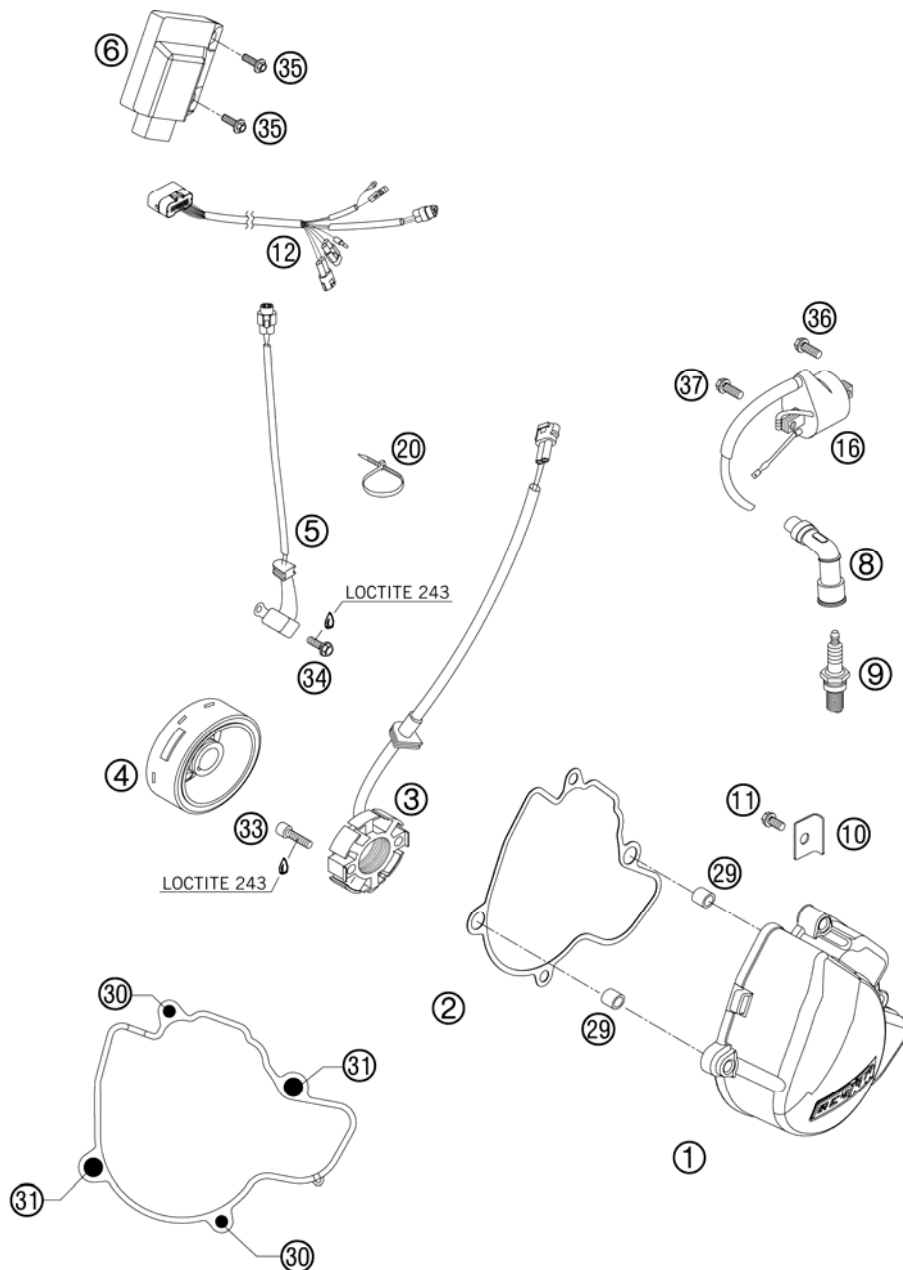
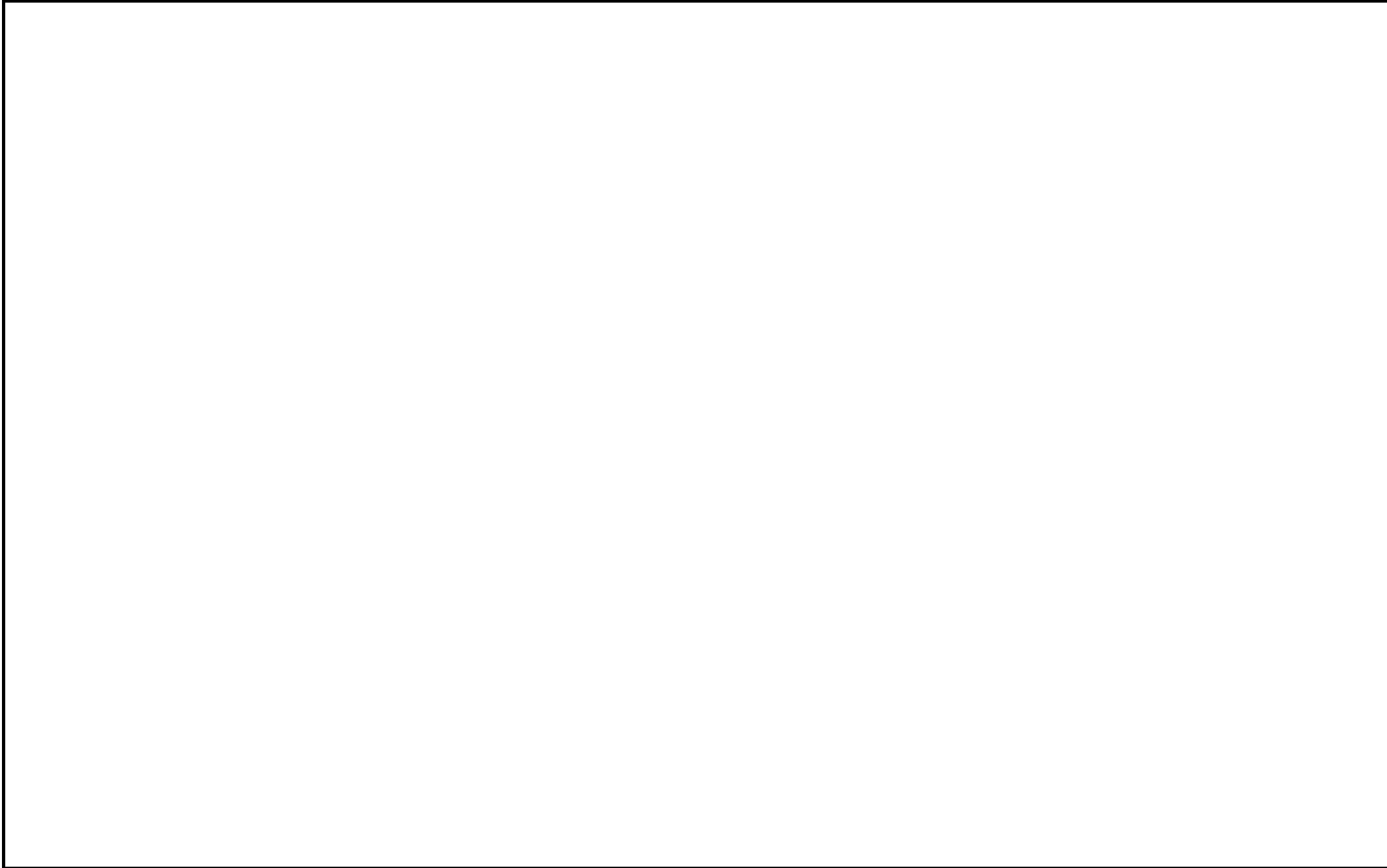

FIG	PART NUMBER	DESCRIPTION	QTY
1*	7703000220025	IGNITION COVER	1
2	77030040000	IGNITION COVER GASKET 05	1
3	77039004000	STATOR 4K3-A 05	1
4	77039005000	FLYWHEEL 05	1
5	59039034000	PULSER COIL KOKUSAN 4K3-A/B	1
6	77039031500	CDI UNIT 250 SXS-F 07	1
8	59039090100	SPARK PLUG CONNECT. VD05EG 03	1
9	77039093000	SPARK PLUG NGK CR9EKB 05	1
10	77030002050	WIRE RETAINING BRACKET 06	1
11	0015060083	HH COLLAR SCREW M 6X8 WS=8	1
12	59439032100	WIRING HARNESS FOR CDI EXC 04	1
16	59039006000	IGNITIONCOIL KOKUSAN 4K3-A/B	1
20	44011076100	CABLE TIE 100/2,5MM BLACK	x
29	49030090000	DOWEL 9,8 X 7 X 10	2
30	0015060253	HH COLLAR SCREW M 6X25 WS=8	2
31	0015060303	HH COLLAR SCREW M 6X30 SW=8	2
33	0912050253	AH SCREW DIN0912-M 5X25	2
34	0015050163	HH COLLAR SCREW M 5X16 WS=8	2
35*	0024060206	HH COLLAR SCREW M6X20 TX30	2
36*	0025060166	HH COLLAR SCREW M6X16 TX30	1
37*	0025060206	HH COLLAR SCREW M6X20 TX30	1

087703912 / C08SXS3911

* NEW PART

X AS REQUIRED









KTM-Sportmotorcycle AG
A-5230 Mattighofen
www.ktm.at

KTM Group Partner



3CM089310HEN



Art.Nr.: 3CM089310HEN 11/2007