

# 250 EXC-F EU 2010





**SPARE PARTS MANUAL: CHASSIS**

ART.NO.: 3CF8103J9EN

ENGLISH



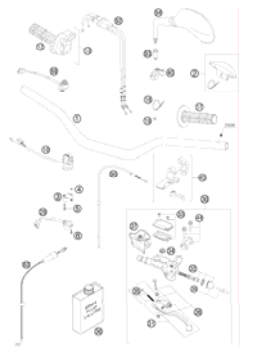
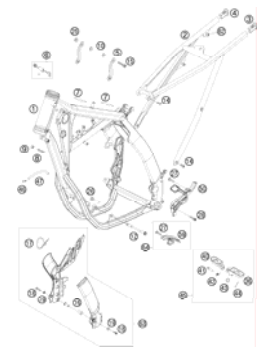
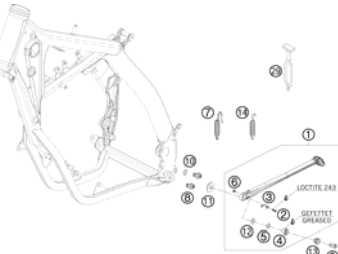
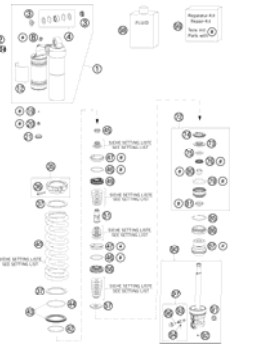
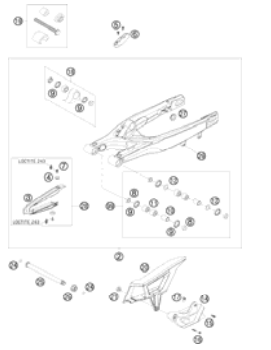
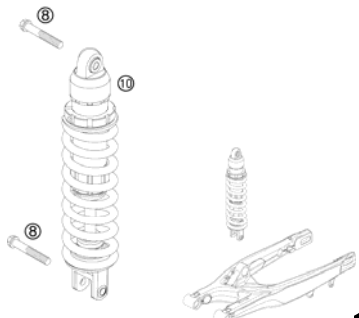

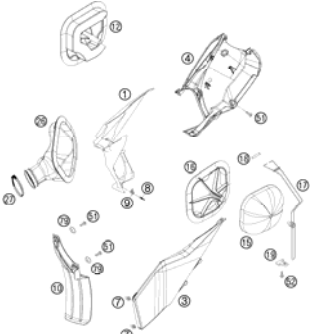
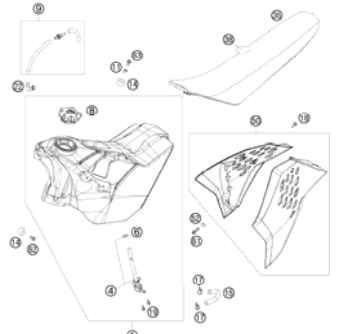
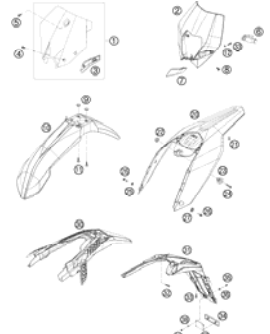
<p><b>FRONT FORK DISASSEMBLED</b></p>  <p><b>4</b></p>	<p><b>FRONT FORK, TRIPLE CLAMP</b></p>  <p><b>6</b></p>	<p><b>HANDLEBAR, CONTROLS</b></p>  <p><b>7</b></p>	<p><b>FRAME</b></p>  <p><b>8</b></p>
<p><b>SIDE / CENTER STAND</b></p>  <p><b>9</b></p>	<p><b>SHOCK ABSORBER DISASSEMBLED</b></p>  <p><b>10</b></p>	<p><b>SWING ARM</b></p>  <p><b>12</b></p>	<p><b>SHOCK ABSORBER</b></p>  <p><b>13</b></p>
<p><b>EXHAUST SYSTEM</b></p>  <p><b>14</b></p>	<p><b>AIR FILTER</b></p>  <p><b>15</b></p>	<p><b>TANK, SEAT, COVER</b></p>  <p><b>16</b></p>	<p><b>MASK, FENDERS</b></p>  <p><b>17</b></p>

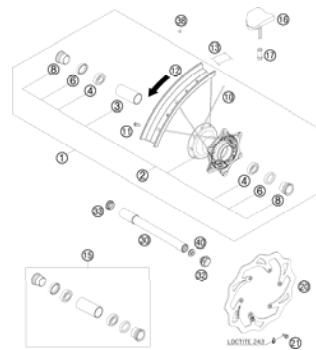
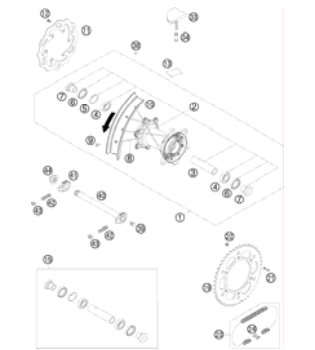
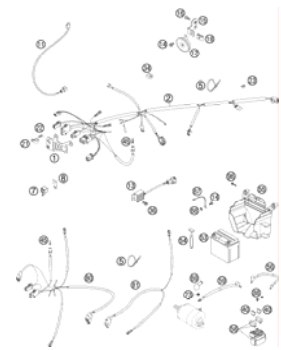
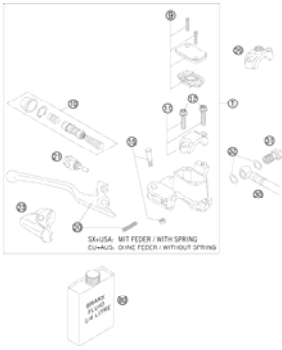
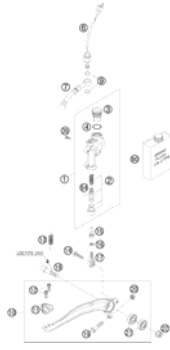
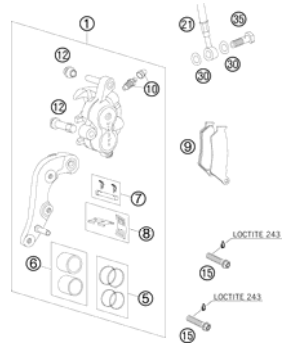
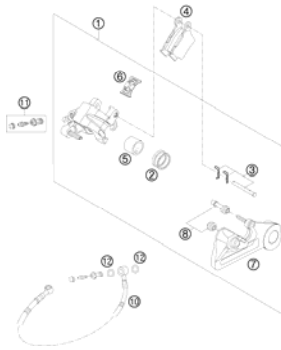
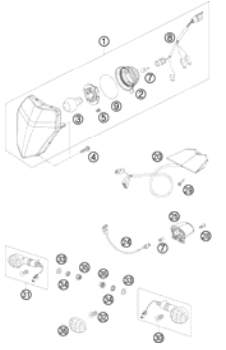
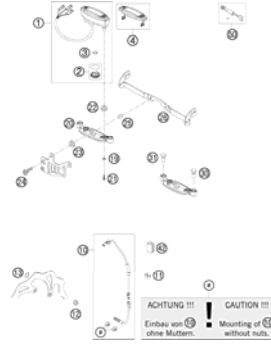
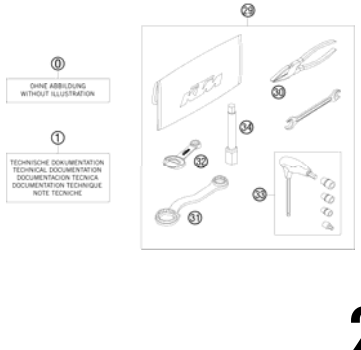
<p><b>DECAL</b></p>  <p><b>18</b></p>	<p><b>FRONT WHEEL</b></p>  <p><b>19</b></p>	<p><b>REAR WHEEL</b></p>  <p><b>20</b></p>	<p><b>WIRING HARNESS</b></p>  <p><b>22</b></p>
<p><b>HAND BRAKE CYLINDER</b></p>  <p><b>23</b></p>	<p><b>REAR BRAKE CONTROL</b></p>  <p><b>24</b></p>	<p><b>BRAKE CALIPER FRONT</b></p>  <p><b>25</b></p>	<p><b>BRAKE CALIPER REAR</b></p>  <p><b>26</b></p>
<p><b>LIGHTING SYSTEM</b></p>  <p><b>27</b></p>	<p><b>INSTRUMENTS / LOCK SYSTEM</b></p>  <p><b>28</b></p>	<p><b>ACCESORIES KIT</b></p>  <p><b>29</b></p>	

		<p>All information contained is without obligation. KTM-Sportmotorcycle AG particularly reserves the right to modify any equipment, technical specifications, prices, colors, shapes, materials, services, service work, constructions, equipment and the like so as to adapt them to local conditions or to cancel any of the above items, all without previous announcement and without giving reasons. KTM may stop manufacturing certain models without previous notice. KTM shall not be held liable for any deviations of availability and/or ability to deliver, illustrations, descriptions, printing and/or other errors. The illustrated models partly contain extra equipment, which is not applied to standard models. © by KTM-SPORTMOTORCYCLE AG, Mattighofen AUSTRIA; All rights reserved; Reprint, also in extracts, with written allowance of KTM-SPORTMOTORCYCLE AG, Mattighofen only.</p>	

# FRONT FORK DISASSEMBLED

250 EXC-F EU 2010

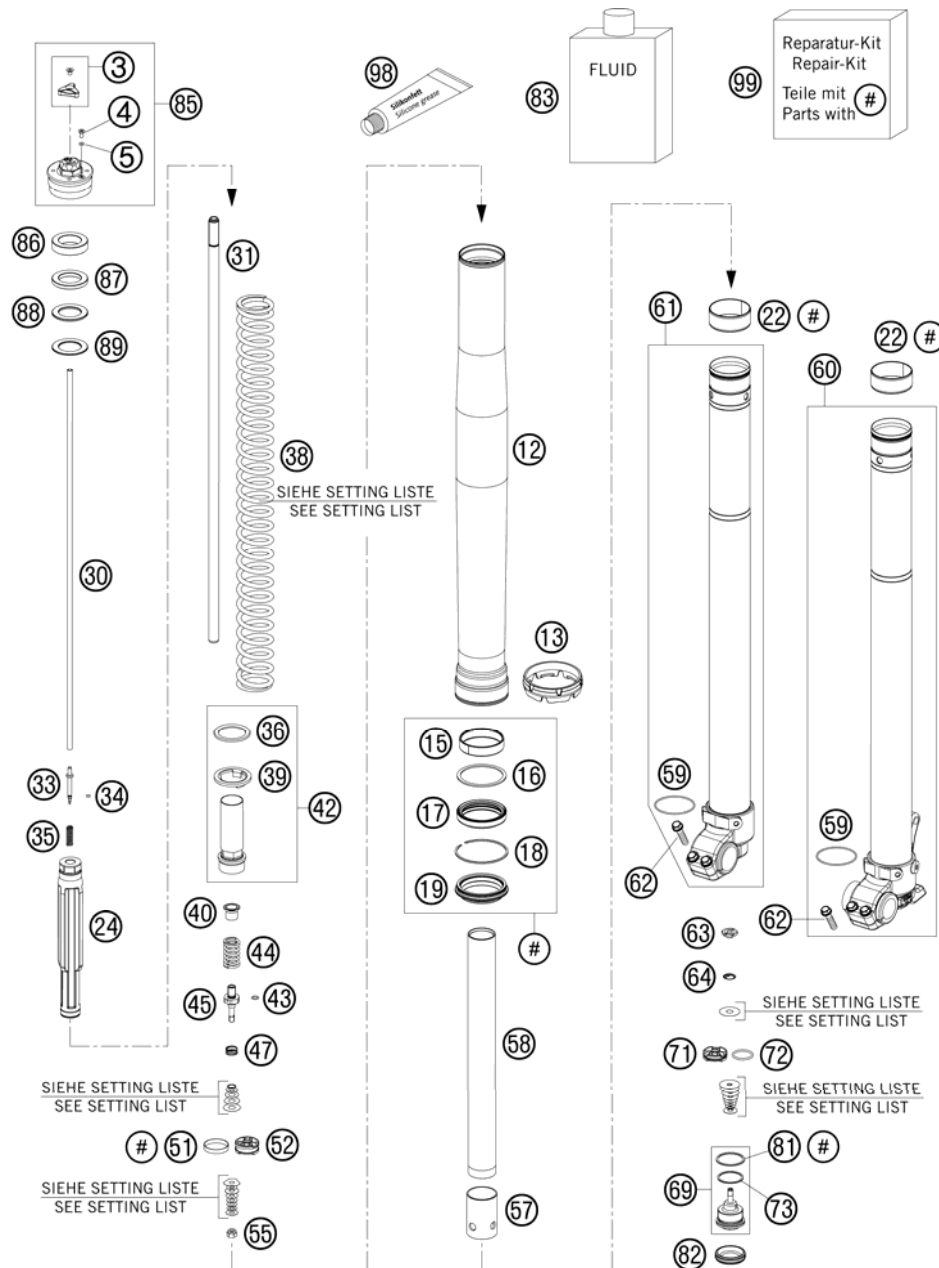

FIG	PART NUMBER	DESCRIPTION	QTY
3	48600812S	ADJUSTING KNOB + SCREW	2
4	48600481	VENT SCREW M4X8	2
5	48600009	O-RING NBR 3,7X1,6	2
12	48600736	OUTER TUBE L577 D54/60MM 2L	2
13	48600698	FORK PROTECTION RING 08	2
15	48600429	DU-BUSH D48XD52X12DDL02	2
16	48600013	SUPPORT RING 50 X 57,6 X 1,5	2
17	48600347	OIL SEAL RING 48X57,8X9,5 03	2
18	48600070	LOCK WASHER SB58	2
19	48600400	DUST CAP D=48 58,4X11,8	2
22	48600428	DU-BUSH D47XD49X20DDL02	2
24	48600557S	HYDR.STOP L=200 D=31,9 CPL. 07	2
30	48600559	ADJUSTING TUBE L=520 07	2
31	48600568	PISTON ROD D=12 L=554 ALU	2
33	48600277	ADJUSTER NEEDLE 07	2
34	48600298	O-RING 2X1,5 NBR	2
35	48600444	REBOUND SPRING C=4N/MM	2
36	48600113	WASHER 32X42X2,5	2
38	91410012S	SPRING 3,8N/MM SET D=4,9MM	x
38	91410013S	SPRING 4,0N/MM SET D=5,0MM	x
38	91410014S	SPRING 4,2N/MM SET D=5,0MM	x
38	91410015S	SPRING 4,4N/MM SET D=5,1MM	x
38	91410016S	SPRING 4,6N/MM SET	x
38	91410017S	SPRING 4,8N/MM SET	x
39	48600021	INTERM. RING 26,2 X 43 X 3	2
40	48600525	GUIDING BUSH REBOUND SPRING	2
42	48600762S	SCREW SLEEVE M27X,08 L=100 KPL	2
43	48600299	O-RING 6X1,2 NBR	2
44	48600511	REBOUND SPRING L=32 C=17	2
45	48600576	PISTON ROD REBOUND	2
47	48600382	SHUTTLE VALVE SPRING C=0,4	2
51	48600455	PISTON RING 5X1X68	2
52	48600575	PISTON REBOUND SX 2007	2
55	40540486	NUT M6X0,5 REBOUND	2
57	48600764	ADAPTER SLEEVE D23/D28	2
58	48600763	PIPE D23/L350 09	2

095030130 / C105030130

\* NEW PART

X AS REQUIRED

# FRONT FORK DISASSEMBLED

250 EXC-F EU 2010

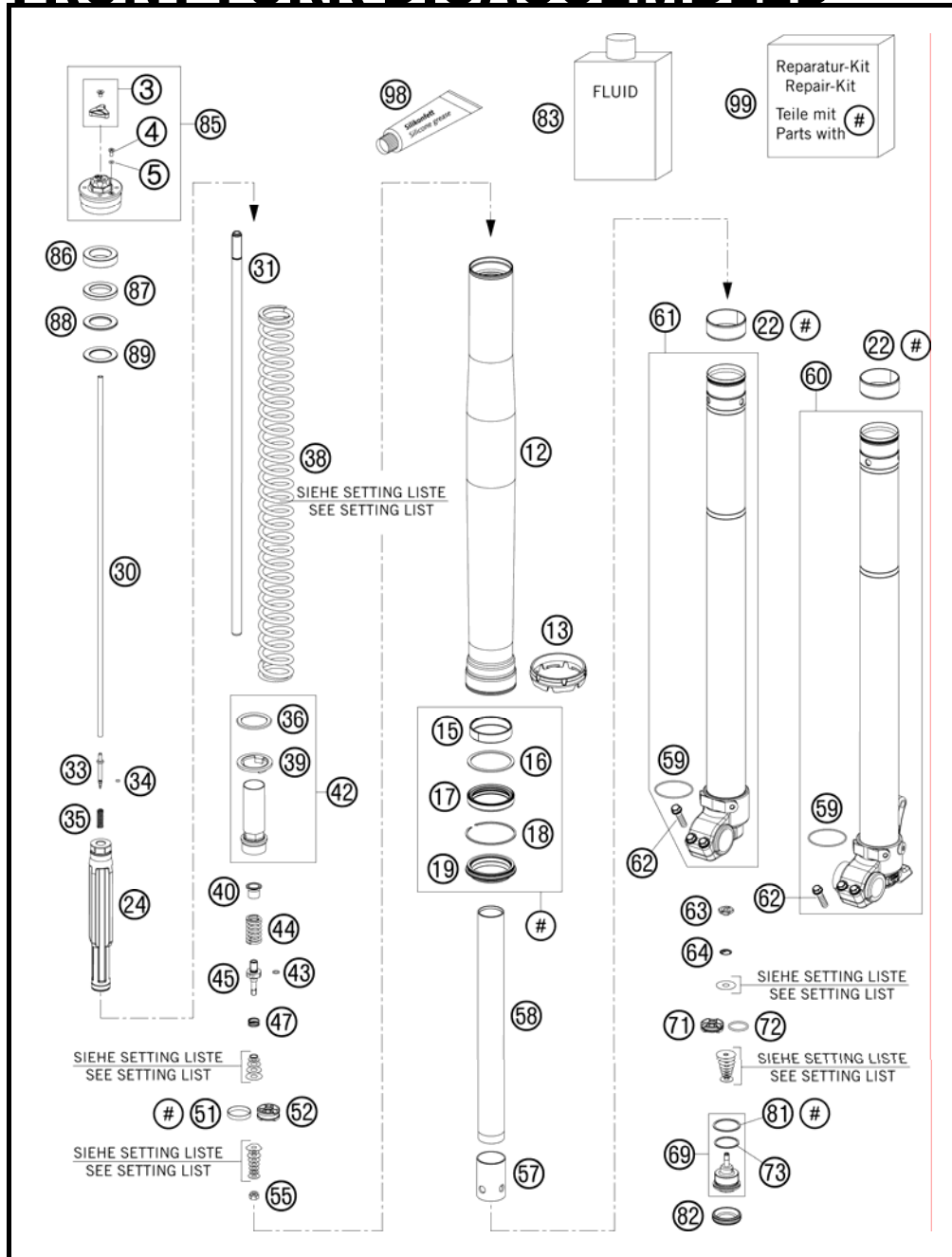

FIG	PART NUMBER	DESCRIPTION	QTY
59	48600048	O-RING NBR 46 X 2	2
60	48600237S3	AXLE CLAMP L/S + TUBE CPL. 09	1
61	48600238S4	AXLE CLAMP R/S + TUBE CPL. 09	1
62	0025080256	HH COLLAR SCREW M8X25 TX40	4
63	48600163	CHECK VALVE NUT M6X0,5 D=2	2
64	48600202	SPRING CHECK VALVE D=0,7	2
69	48600586S	TAP COMPRESSION CPL. 07	2
71	48600047	PISTON COMPRESSION D=27,9	2
72	46811499	O-RING NBR 21X2	2
73	35480320	O-RING NBR 24X2	2
81	48600004	COPPER WASHER 29,5X33,5X1	2
82	48600141	RUBBER CAP D=35MM	2
83	48600765S1	FORK OIL SAE5 5L 2008	1
85	48600431S2	PRE-LOAD ADJ. M51X1,5 09	2
86	48600038	SPACER 42X26,5X10	2
87	48600037	SPACER 42X26,5X5	2
88	48600036	SPACER 42X26,5X2,5	2
89	48600053	SPACER 42X26,5X1,5	2
98	T511	SILICONE GREASE F. DUST STRI	1
99	R14016	REPAIR-KIT EXC FRONT FORK 2009	1

095030130 / C105030130

\* NEW PART

X AS REQUIRED

# FRONT FORK, TRIPLE CLAMP

250 EXC-F EU 2010

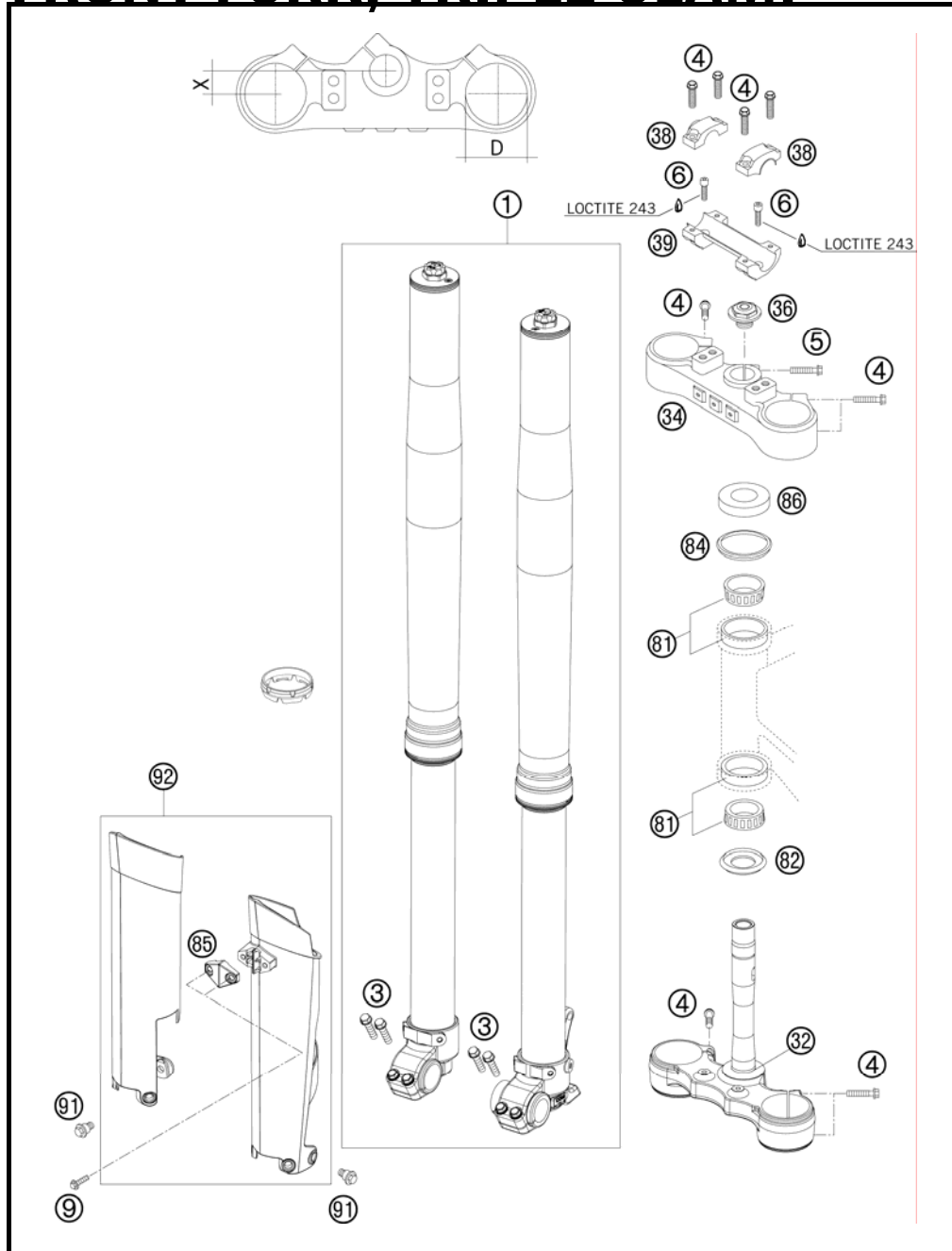

FIG	PART NUMBER	DESCRIPTION	QTY
1	14187E0401	FORK KTM 250/300 EXC/F/W 2009	1
3	0025080256	HH COLLAR SCREW M8X25 TX40	4
4	0025080306	HH COLLAR SCREW M8X30 TX40	12
5	0025080356	HH COLLAR SCREW M8X35 TX40	1
6	0912100250	AH SCREW DIN6912-M10X25,10.9,L	2
9	0017060204	EJOT PT SCREW K60X20 ALU WS=6	2
32	59001232020	BOT.FORK PLATE CPL.	1
34	59001034120	TOP TRIPLE CLMP X=20MM/D=54MM	1
36	54801036000	STEER.HEAD SCREW M20X1,5 WS=27	1
38	59001038200	HANDLEBAR CLAMP D=28MM 2000	2
39	59001039100	HANDLEBAR SUPPORT 28MM SC'99	1
81	54201081100	TAPERED ROLLER BEARING CPL. 06	2
82	54601084200	O-RING SUPPORT W. SEALING LIP	1
84	54601184000	STEERING HEAD GASKET TOP	1
85	7800108500004	CLAMP FOR SPEED CABLE D=6MM 08	1
86	54201086000	STEERING HEAD COVER	1
91	59001092050	SPECIAL SCREW M6X12,5 WS=8	6
92	7800109400004	FORK PROTECTIO LE+RI ORANGE 08	1

085030113 / C105480111

\* NEW PART

X AS REQUIRED





# HANDLEBAR, CONTROLS

250 EXC-F EU 2010

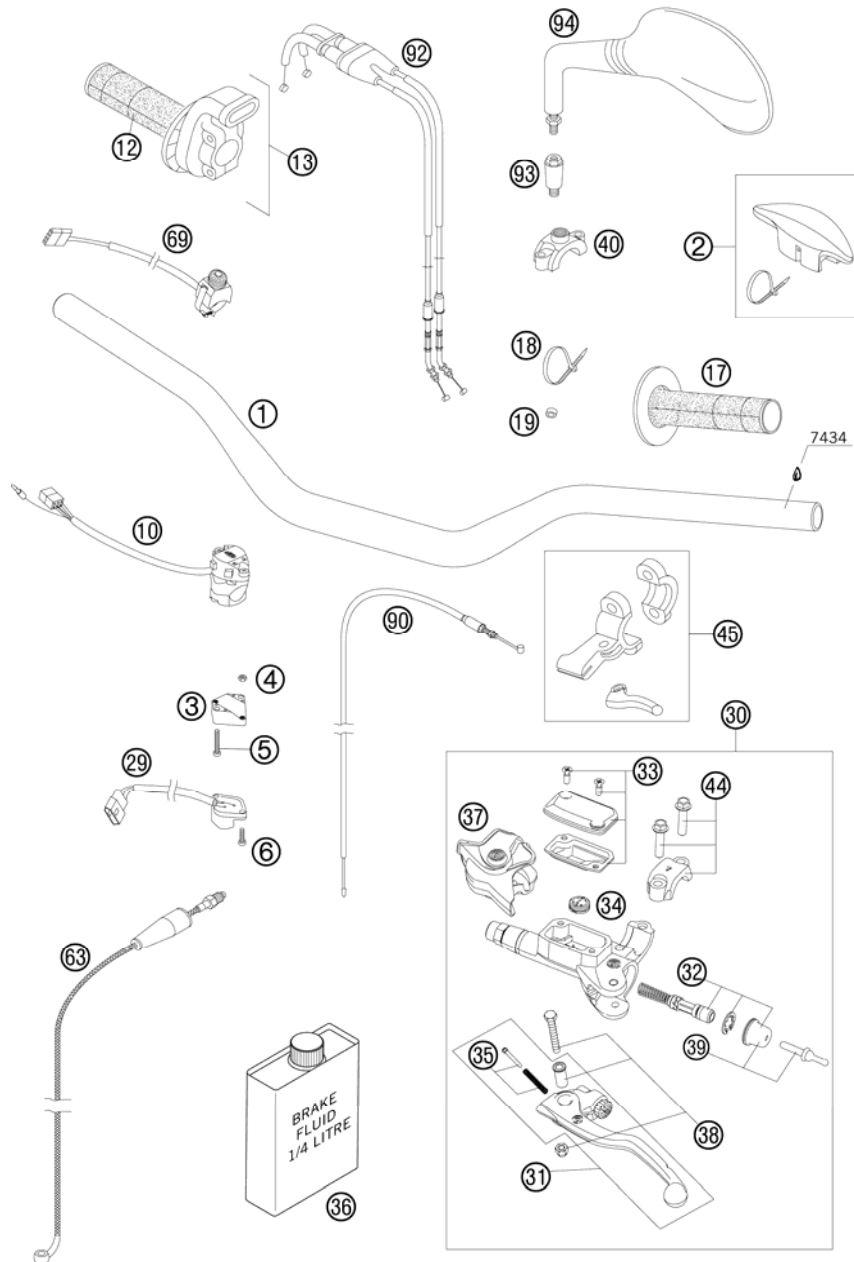

FIG	PART NUMBER	DESCRIPTION	QTY
1	5480200130017	HANDLEBAR NEKEN D=28MM EXC 07	1
2	59002002000	HANDLEBAR PAD 05	x
3	13011070060	ADAPTER FOR FLASHER SWITCH '98	1
4	0934040003	HEXAGON NUT DIN0934-M 4	2
5	0084040223	CYL.HEAD SCREW DIN0084-M 4X22A	2
6	0985040203	FLAT HEAD SCREW DIN7985-M 4X20	2
10	50311070000	H.LIGHT SWITCH CEV 2/4TAKT '98	1
12	54802013000	TWIST GRIP COVER RENTHAL 04	1
13	59402010000	THROTTLE GRIP CPL. RACING 2004	1
17	54802039000	FIXED GRIP RENTHAL 04	1
18	44011076100	CABLE TIE 100/2,5MM BLACK	x
18	44011076200	CABLE TIE 200/3,6MM BLACK	x
19	50301089000	SPACER BUSHING 6X10X5	1
29	50311029000	FLASHER SWITCH CEV '98	1
30	54802030044	MASTER CYLINDER CPL. 06	1
31	54802031000	CLUTCH LEVER CPL. BREMBO 06	1
32	54802032000	REP. KIT PISTON 06	1
33	54802003000	COVER HYD. CLUTCH CPL.	1
34	54802051000	VALVE	1
35	54802052000	BOLT KPL.	1
36	00062030000	BRAKE FLUID DOT5.1 0,25L	1
37	54802037000	PROTECTION CAP 06	1
38	54802038100	LEVER SCREW CPL. 06	1
39	54802046000	PUSH ROD CPL.	1
40	58012040150	CLAMP FOR MIRROR '94	x
44	54802005100	CLAMP CPL. 06	1
45	78002050000	LEVER F. COLD START ACT. 08	1
63	54832063000	CLUTCH PIPE 06	1
69	59411074000	STARTER CONTROL 04	1
90	78031078000	CABLE F. COLD START ACT. 08	1
92	77002091000	THROTTLE CABLE 250 SXF 2005	1
93	58412040050	SUPPORT FOR MIRROR LC4 '98	2
94	58412040000	MIRROR L/S 98	1
94	58412041000	MIRROR R/S 98	1

097800212 / C097800212

\* NEW PART

X AS REQUIRED

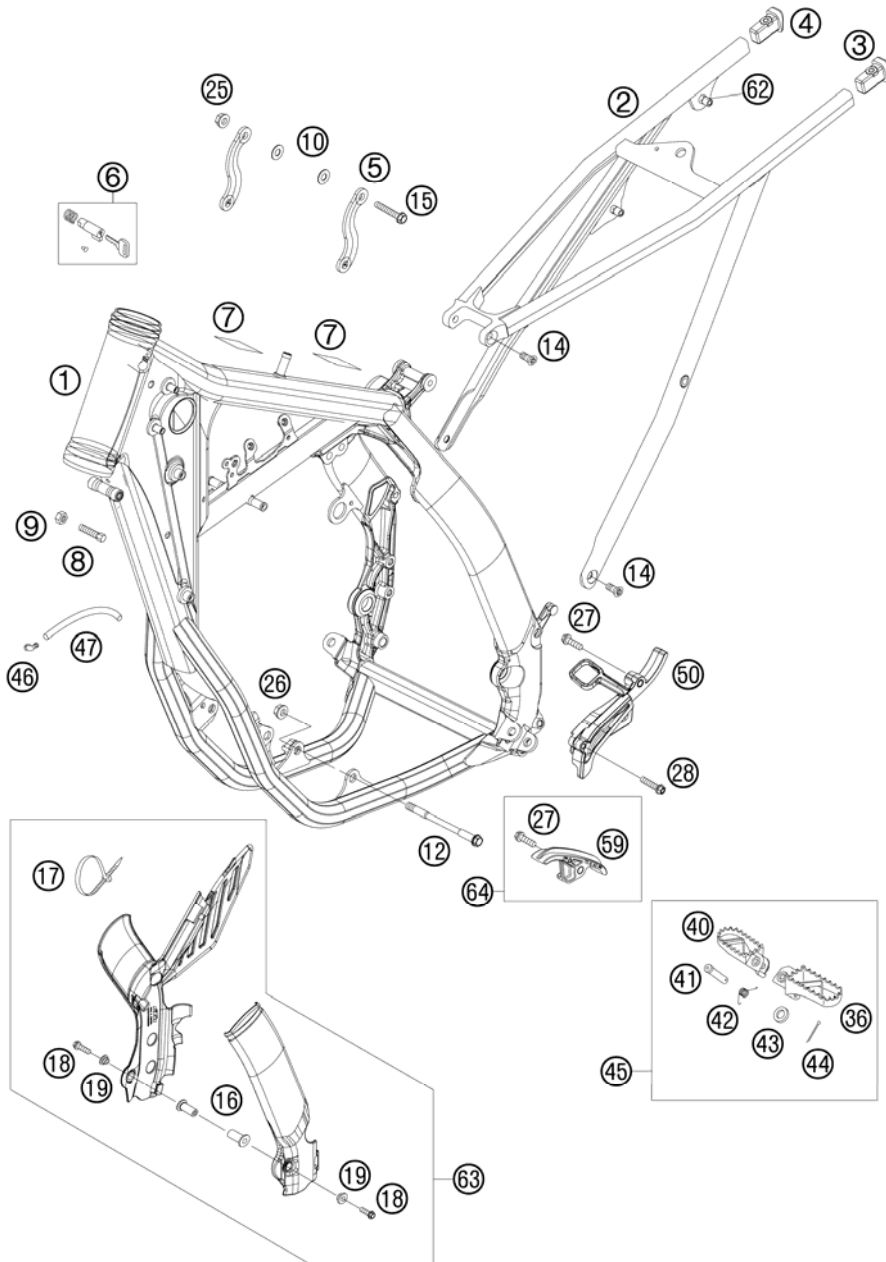

FIG	PART NUMBER	DESCRIPTION	QTY
1	7700310120030	FRAME 250 EXC-F EU "GC08" 08	1
2	77303002000	SUB FRAME SX "Q7" 07	1
3	78003002010	SUB FRAME APPLICATION LEFT 08	1
4	78003002020	SUB FRAME APPLICATION RIGHT 08	1
5	77003113200	REINFORCING B. 250 SX-F 09	2
6	78003035000	STEERING HEAD LOCK 08	1
7	50307012000	ADH. FOIL TRANSP. 80X80 MM 04	2
8	59001037000	SPECIAL SCREW M8X26 WS=10	2
9	0934080003	HEXAGON NUT DIN0934-M 8	2
10	77003013050	WASHER 8,5X18X1 INOX	4
12	54603013000	ENGINE BRAC.SCR. M10X105 WS=13	2
14	0019080206S	FLAT HEAD SCREW M. ISA45 M8X20	4
15	56530079000	COLLAR SCREW M8X42 WS=13 10.9	2
16	54803092050	BLIND PLUG-IN NUT M5 WN 22A 03	2
17	44011076305	CABLE TIE 300/4,8MM BLACK	3
18	0738050250	COU.SUNK SCR. AH ISO7380 M5X25	2
19	54803092060	BUSH F. FRAME PROTECTION 03	2
25	54310086200	SELF LOCKING NUT M8 10.9	2
26	54310086100	SELF LOCKING NUT M10 CU WS=14	2
27	0025080306	HH COLLAR SCREW M8X30 TX40	2
28	0025060406	HH COLLAR SCREW M6X40 TX30	1
36	59003040250	FOOT PEG L/S SILVER 02	1
40	59003041250	FOOT PEG R/S SILVER 02	1
41	54803044000	BOLT FOR FOOT PED 03	2
42	54603041000	FOOTREST SPRING L/S & R/S	2
43	0125100003	WASHER DIN0125-A10,5	2
44	0094032253	PIN DIN0094-3,2X25 STEEL	2
45	5030314013390	FOOTPEG L.+R. CPL. 03	1
46	50303089000	ANGEL PIECE '97	1
47	55007016001	PVC-HOSE 7X10 PER METER	x
50	77003096000	SPROCKET COVER 250 SX-F 07	1
59	77303053000	CHAIN SLIDING PIECE BELOW 07	1
62	77303139000	BLIND RIVET NUT EM6-60LF/HX	4
63	77303094100	PLASTIC FRAME PROTECTION SET	1
64	77303053010	CHAIN SLIDING P. BELOW CPL. 07	1

097800312 / C097800312

\* NEW PART

X AS REQUIRED

# SIDE / CENTER STAND

250 EXC-F EU 2010

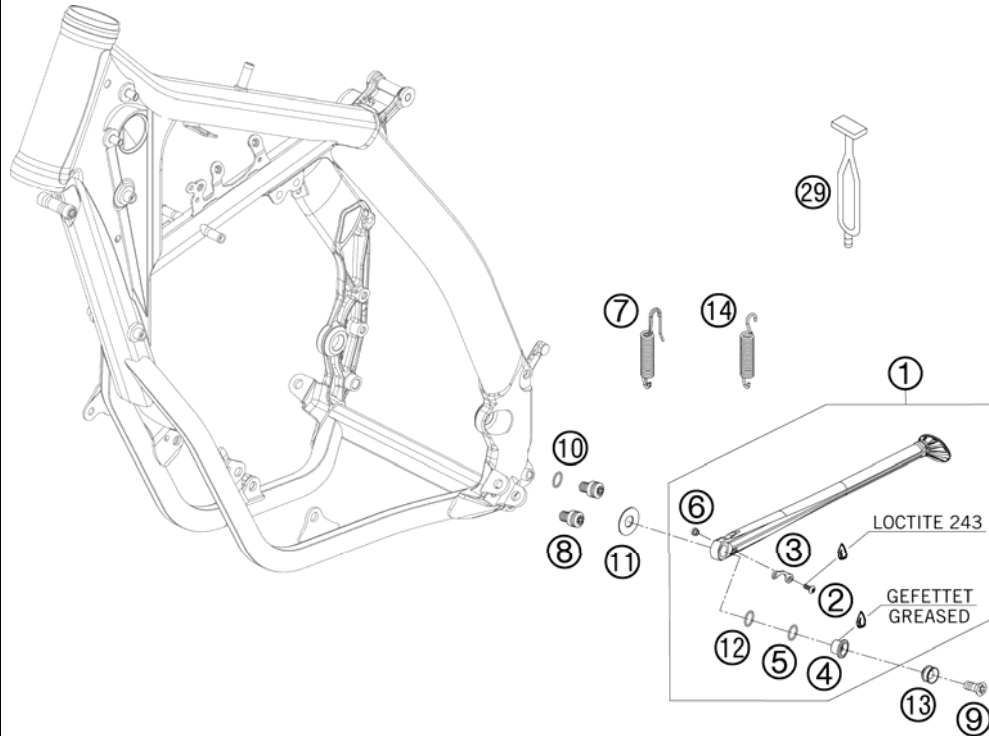

FIG	PART NUMBER	DESCRIPTION	QTY
1	78003023044	SIDE STAND CPL. 08	1
2	58605083014	SCREW M5X14 TORX 25 07	1
3	78003023090	SPRING BRACKET F. SIDE ST. 08	1
4	78003023080	SIDE STAND BUSHING EXC USA 08	1
5	0770180020	O-RING 18,00X2,00 NBR 70	1
6	78003023070	SPACER BUSH. SPRING BRACKET	1
7	78003024100	SIDE STAND SPRING 08	1
		ONLY FOR EXC	
8	78003023182	SIDE STAND STOP SCREW M10X12	2
9	0019080266S	COUNTER-SUNK SCREW ISA45 M8X26	1
9	0025080306	HH COLLAR SCREW M8X30 TX40	1
		ONLY FOR EU	
10	0770120020	O-RING 12,00X2,00 NBR 70	1
11	78003023083	WASHER F. SIDE STAND 12,2X29,5	1
12	0770125015	O-RING 12,5X1,5 NBR	1
13	78003023081	SIDE STAND BUSHING EXC-EU 08	1
		ONLY FOR EU	
14	78003024100	SIDE STAND SPRING 08	1
		ONLY FOR XC	
29	50303018000	RUBBER L=145MM	1

085230360 / C105230360

\* NEW PART

X AS REQUIRED

# SHOCK ABSORBER DISASSEMBLED

250 EXC-F EU 2010

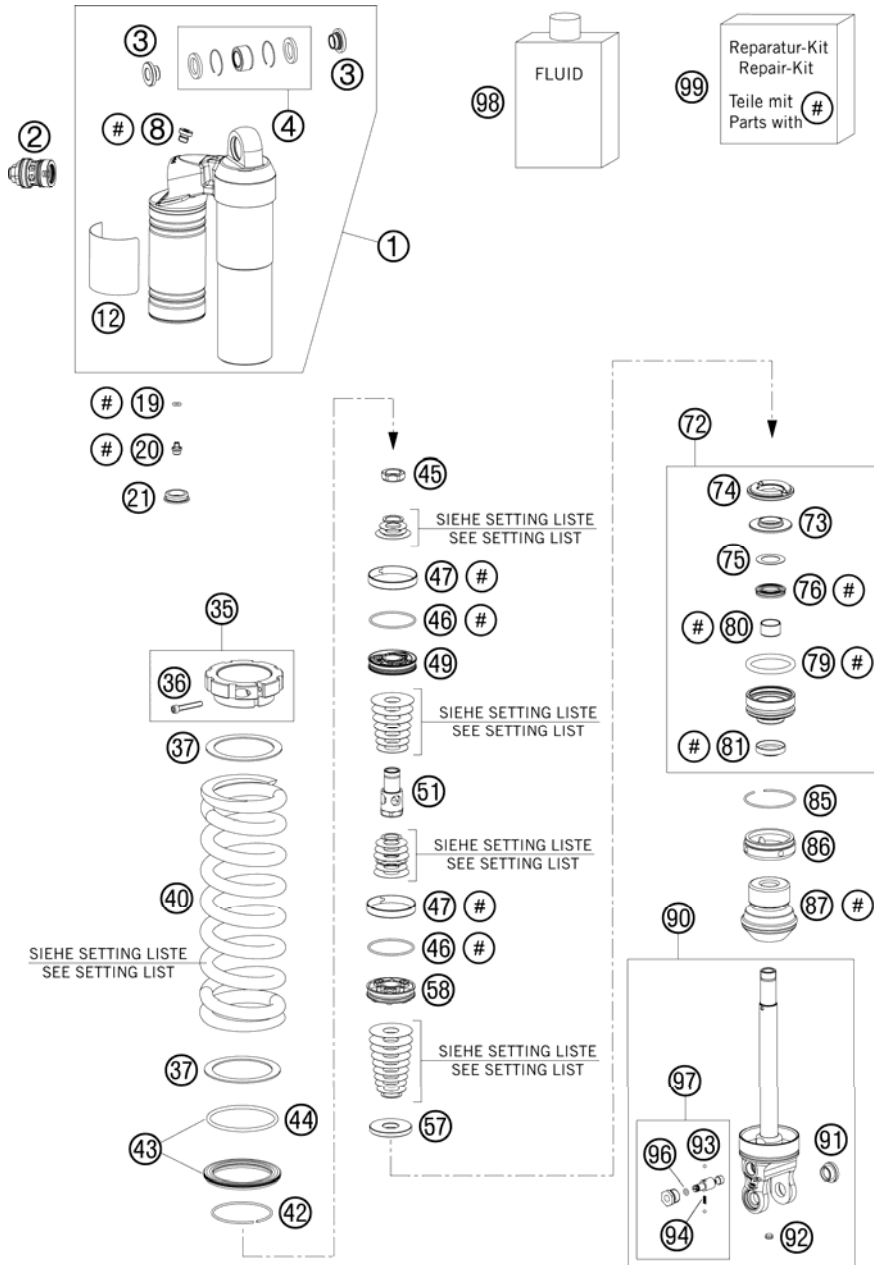

FIG	PART NUMBER	DESCRIPTION	QTY
1	50180733S4	TOP PART CPL. M57,5X1 H30,5 09	1
2	50180213S10	DCC-COMPR.DAMP.CONTROL CPL. 07	1
3	46180007	ADAPTOR BUSH KGW 12X24	2
4	R12012	REP. KIT BEAR./SEAL UP. 07	1
8	50180095	BLEED PLUG R 1/8	1
12	52000041	WP CAUTION (PDS KTM) 58X83	1
19	46810893	O-RING NBR 5,28X1,78	1
20	36120151	SCREW PLUG M5X6	1
21	46811208	RUBBER CAP "DO NOT OPEN"	1
35	50180520S	SPRING RETAINER M57,5X1 +SCREW	1
36	50180327	AH SCREW M5X30 DIN912	1
37	50180114	INTERM.RING SCREW SPRING RET.	2
40	91210053S	SPRING 250 63N/MM ORANGE	x
40	91210054S	SPRING 250 66N/MM ORANGE	x
40	91210068S	SPRING 250 69N/MM ORANGE	x
40	91210069S	SPRING 250 72N/MM ORANGE	x
40	91210070S	SPRING 250 76N/MM	x
42	50180273	CIRCLIP 58,2X2	1
43	50180463S	SPRING RET. D=80 W. O-RING 05	1
44	50180352	O-RING VITON 66,27X3,53	1
45	50180627	PISTON ROD NUT M20X1	1
46	50180099	O-RING VITON 44,17X1,78	2
47	50180135	PISTON RING 50-8	2
49	50180675	PISTON D=20	1
51	50180764	TAP D20 M20X1 L45,3 09	1
57	50180631	REBOUND DISC D43 H0 T4	1
58	50180197	PISTON 6+6X7/4,5	1
72	50180603S	ADAPTOR CPL. D=50 H=28 08	1
73	50180113	STEEL DISC 18X,5X43,7X6	1
74	50180107	REBOUND RUBBER	1
75	50180604	SHIM D29,75 X D19 X T0,4 08	1
76	50180605S	SEAL D18X30X5 08	1
79	50180103	O-RING 41X5	1
80	46180119	DU-BUSH 18X20X12	1
81	50180606	DUST SEAL 1828 08	1
85	50180126	CIRCLIP 53X1,75	1

095030430 / C095030430

\* NEW PART

X AS REQUIRED

# SHOCK ABSORBER DISASSEMBLED

250 EXC-F EU 2010

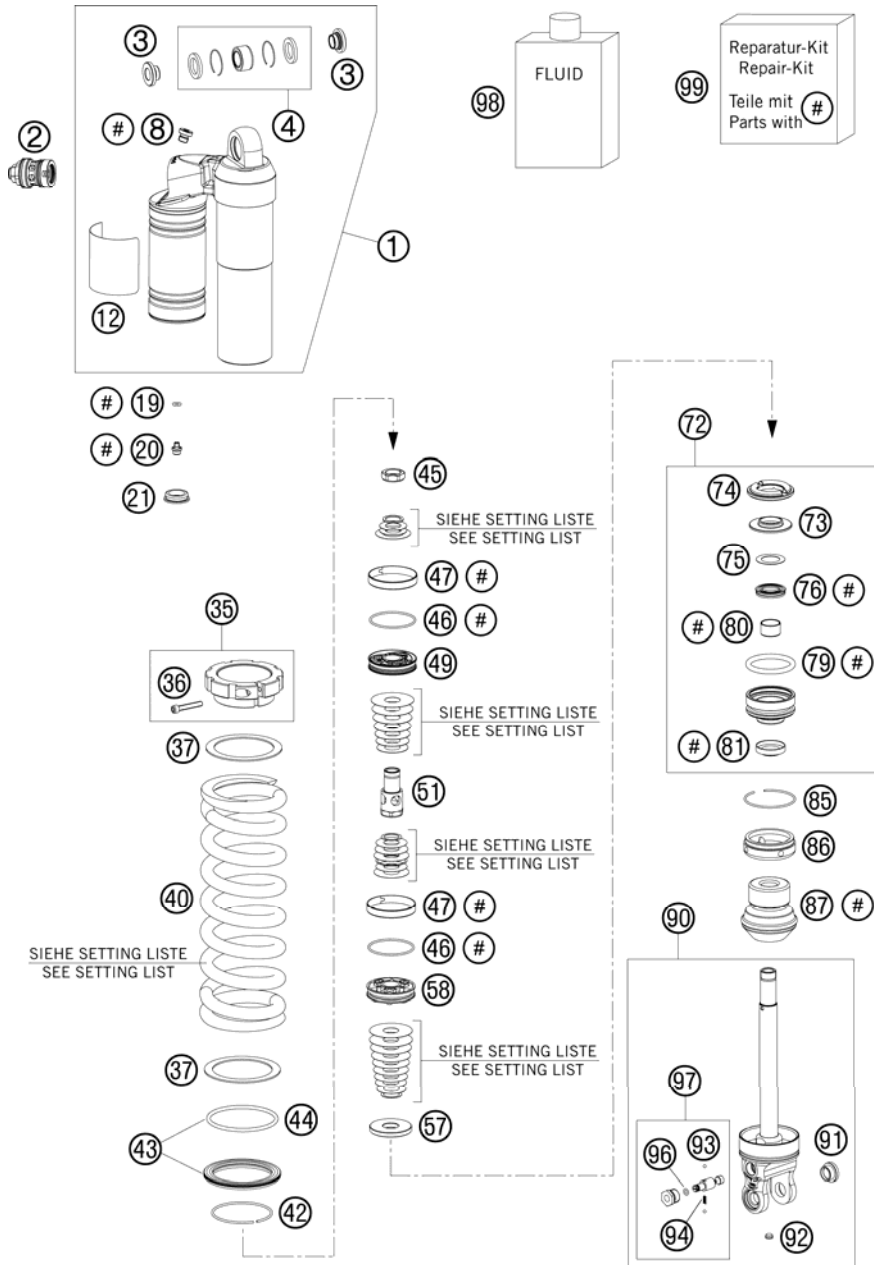

FIG	PART NUMBER	DESCRIPTION	QTY
86	50180626	RESERVOIR CAP D=50 H=10 09	1
87	50180600	BUMP RUBBER D58 D17 H59 2008	1
90	50180512S3	SHOCK ABS. LOWER PART CPL. 09	1
91	50180105	THREADED BUSH M12 PDS	1
92	50180297	RUBBER PLUG D=8	1
93	40540603	STEEL BALL D=3MM	2
94	48600028	SPRING D=2,9 L=7,9	1
96	50180222	O-RING NBR 4X1,5	1
97	50180434S	ADJUSTING SCREW REBOUND TRAVEL	1
98	50180342S1	SHOCK ABSORBER FLUID 5 LT '03	1
99	R12014	REPAIR KIT 5018 PDS 06	1

095030430 / C095030430

\* NEW PART

X AS REQUIRED

# SWING ARM

250 EXC-F EU 2010

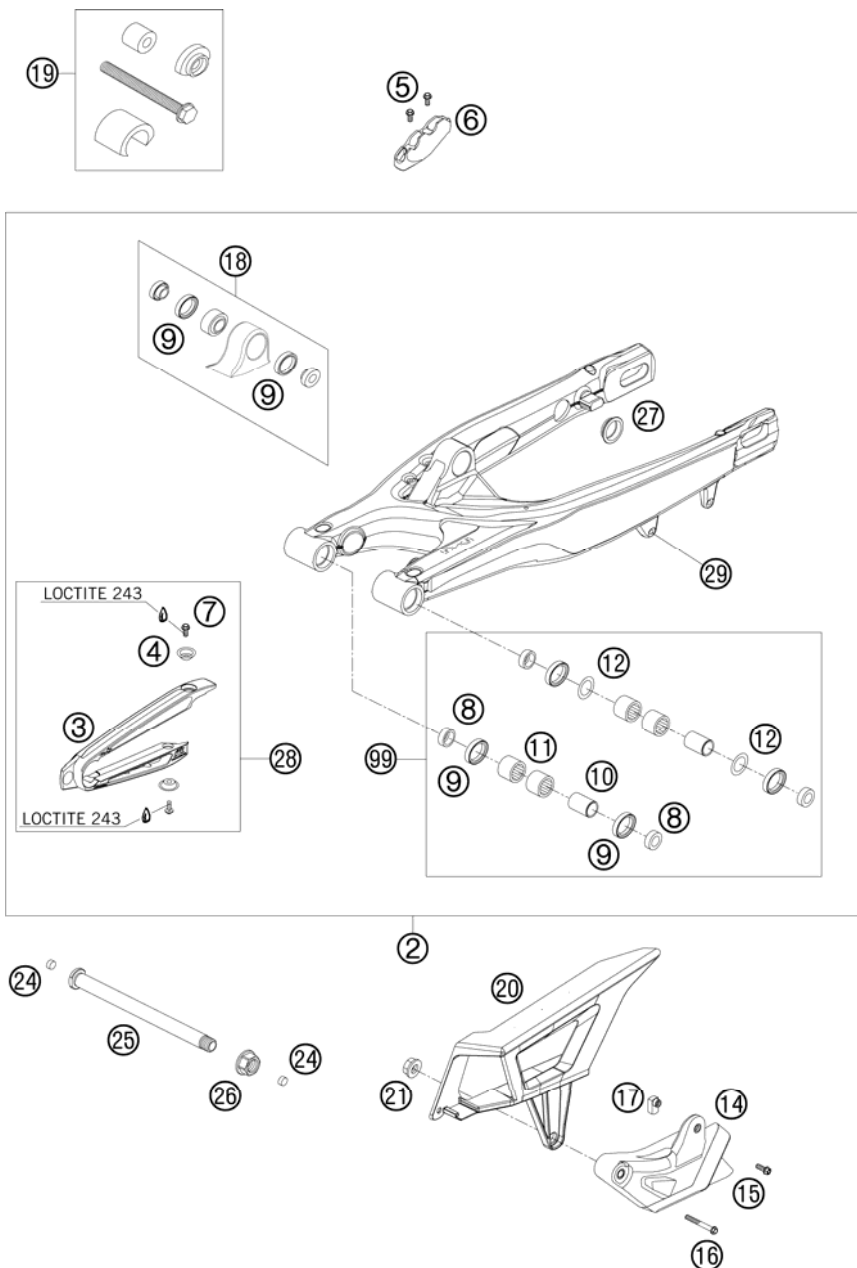

FIG	PART NUMBER	DESCRIPTION	QTY
2	77304030044	SWINGARM CPL. 07	1
3	77304066000	CHAIN SLIDING PROTECTION	1
4	77304066050	BUSHING F. CHAIN SLIDING PR.07	2
5	0009050103	SPECIAL SCREW M 5,0X10	2
6	77313047000	BRAKE HOSE GUIDE LOWER 07	1
7	59009062013	SPECIAL SCREW M6X13 WS=8 10.9	2
8	54804034000	BUCKET F. SHAFT SEAL RING 03	4
9	0760253270	SHAFT SEAL RING 25X32X7	6
10	54804032000	BUSHING SLEEVE F. SWING ARM 03	2
11	58033097000	NEEDLE BEARING HK 2216	4
12	54603036000	STOP DISK 22,2X31,7X1	2
14	78004070000	CHAIN GUIDE CPL.	1
15	59009062019	SPECIAL SCREW M6X19 WS=8 10.9	1
16	0025060506	HH COLLAR SCREW M6X50 TX30	1
17	77304070030	INSERTION NUT F. CHAIN GUIDE	1
18	50304090044	PIVOT BEARING+BUSHES PDS '99	1
19	50329000044	TOOL BEARING MOUNTING PDS	1
20	78004060000	CHAIN GUARD 08	1
21	56509064100	SELF LOCKING NUT M6 10.9	1
24	55009086000	PLUG SFL13	2
25	77304037000	SWINGARM BOLT M16X1,5 07	1
26	54804038000	SELF LOCK.NUT M16X1,5 WS=19 03	1
27	58404041100	CLOSING COVER ROUND 03	4
28	77304066010	CHAIN GUARD CPL. 06	x
29	54603055051	PRESS IN NUT M6 STEEL ZINC	1
99	54804230210	SWINGARM REPAIR KIT 05-07	x

085030491 / C095030491

\* NEW PART

X AS REQUIRED

# SHOCK ABSORBER

250 EXC-F EU 2010

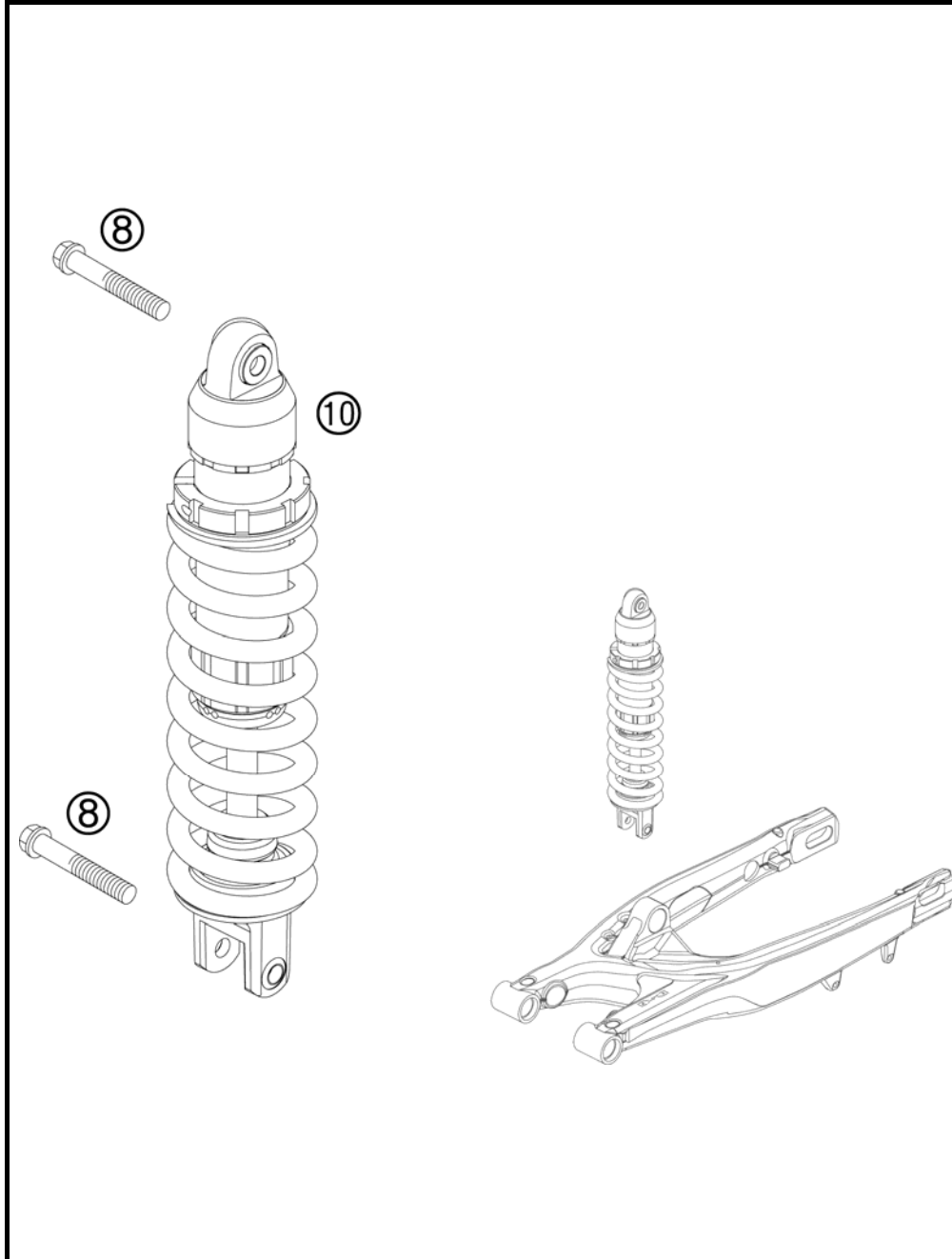

FIG	PART NUMBER	DESCRIPTION	QTY
8	0025120506S	HH COLLAR SCREW M12X50 TX45	2
10	12187E04	MONOSH. PDS B07MA250/300EXC 09	1

085030410 / C095480411

\* NEW PART

X AS REQUIRED

# EXHAUST SYSTEM

250 EXC-F EU 2010

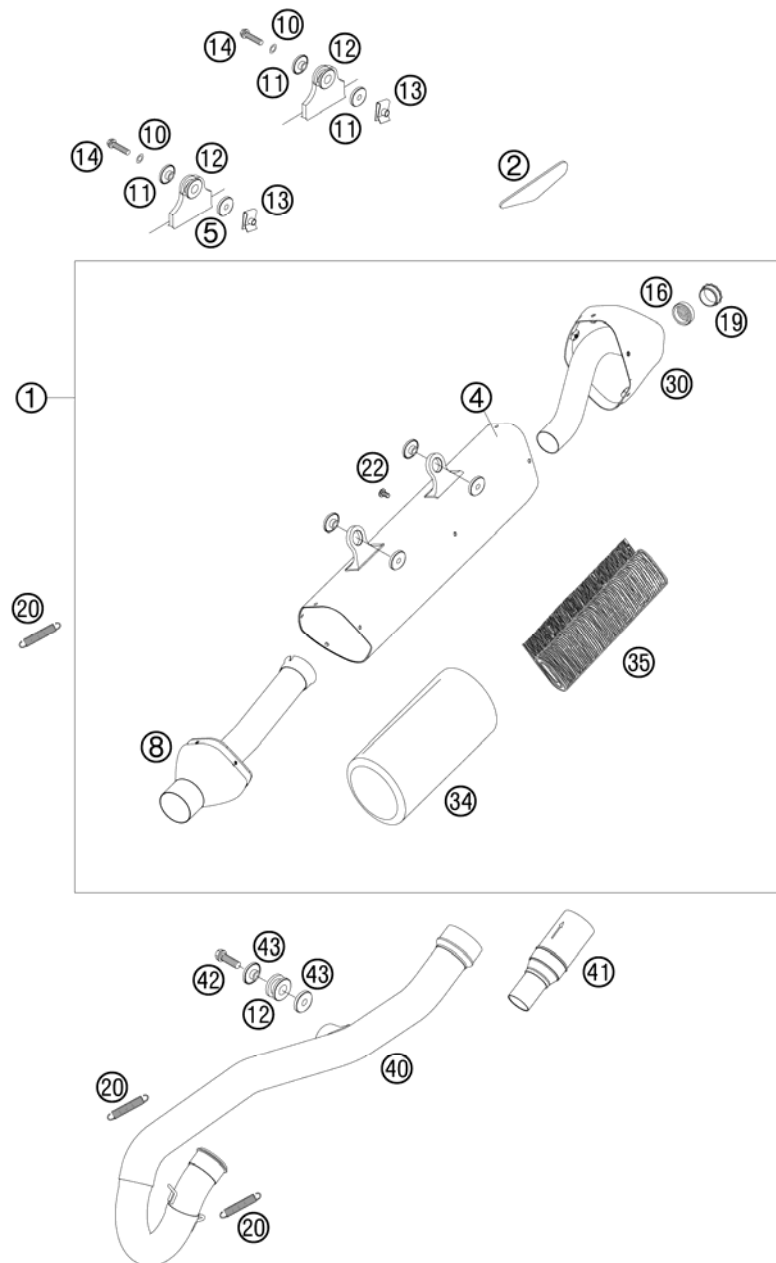

FIG	PART NUMBER	DESCRIPTION	QTY
1	77005081000	SILENCER EXC-F THROTTLED 07	1
2	77308013050	THERMAL PROTECTION FOIL 07	1
4	77005081050	SILENCER HOUSING EXC-F 07	1
5	59405169000	BUSHING SIL.-SMR REAR 2004	1
8	77005081009	SIL. CONNECT. CAP CPL.EXC-F 07	1
10	0137060003	SPRING WASHER DIN0137-B 6	2
11	77305069000	BUSHING 7.5x12x28x7.6 07	4
12	54605068000	EXHAUST BRACKET RUBBER BLACK	3
13	54603048100	RANGE CHANGE METAL NUT M6	2
14	0025060306	HH COLLAR SCREW M6X30 TX30	2
16	77005081065	THROTTLE ELEMENT CPL. EXC 07	1
19	77005081055	SIL. ELEMENT EXC-F 07	1
20	50305016000	TEN.SPRING L=62MM EY.MOVEABLE	3
22	58605083010	SCREW TORX M5X10 05	10
30	77005081007	ENDCAP W. SILENCER ELEMENT 09	1
34	58705078350	STUFFINGYARN 350 GRAMM '99	1
35	77005081016	STUFFING YARN EXC-F 07	1
40	77005007100	EXHAUST MANIFOLD 250 EXC-F 07	1
41	77005009033	CATALYST WELDED EXC 08	1
42	0025080256	HH COLLAR SCREW M8X25 TX40	1
43	59405069000	BUSHING FOR EXHAUST SUPPORT 03	2

087800515 / C097800511

\* NEW PART

X AS REQUIRED



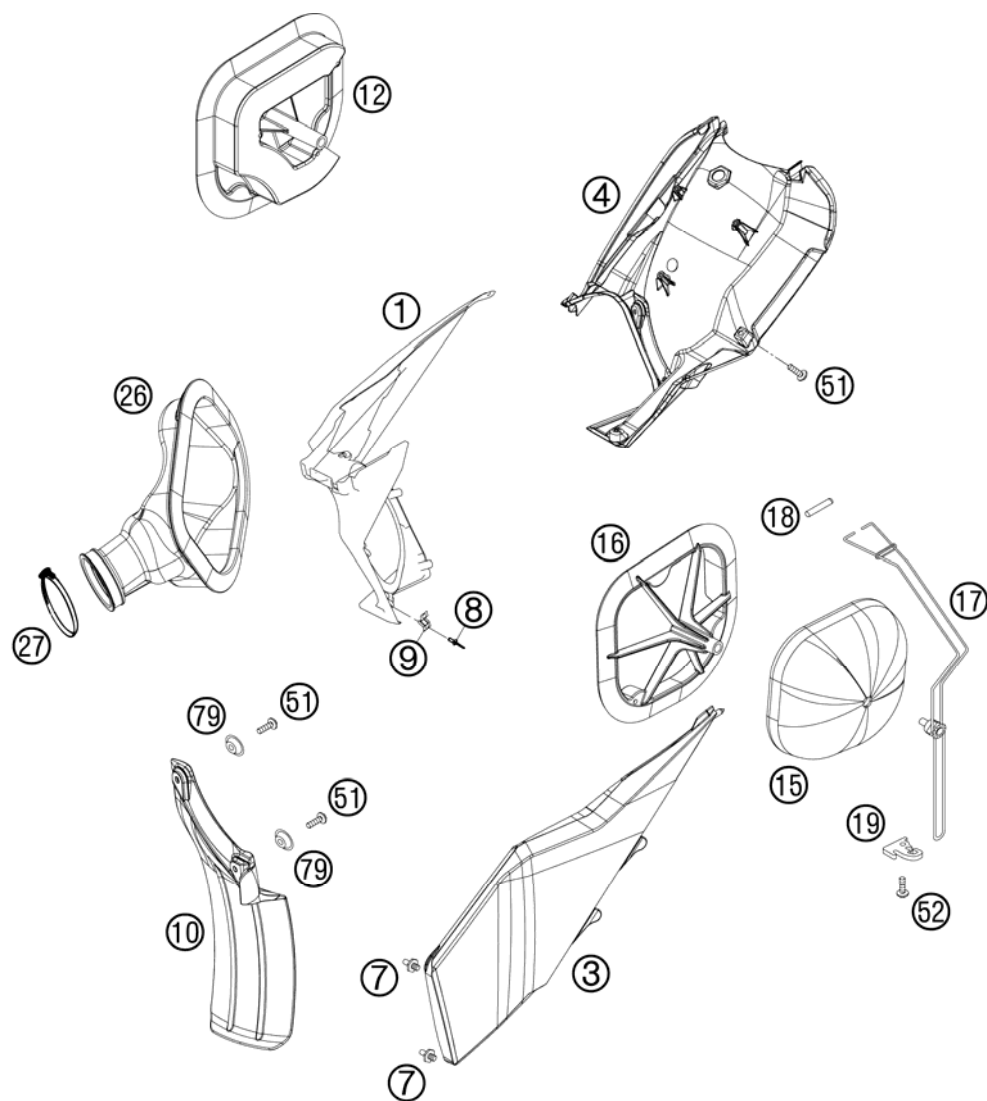

FIG	PART NUMBER	DESCRIPTION	QTY
1	7730600101030	AIR BOX PART RIGHT	1
3	7730600300030	AIR BOX COVER SX BLACK 07	1
4	77306001020	REAR PART FILTER BOX 07	1
7	54806008051	QUICK RELEASE-NIPPLE 03	2
8	54806108052	BLIND RIVET 3,3X9,7 GROOVED 04	4
9	54806008050	QUICK RELEASE-SPRING HANGER	2
10	77306010000	FENDER FOR FILTER BOX	1
12	78006012000	THROTTLE CAP CPL. EXC 08	1
15	77306015000	AIR FILTER 07	1
16	77306016000	FILTER CARRIER 4S SX 07	1
17	77306017000	FILTER SUPPORT CPL. 07	1
18	77306018000	FILTER SUPPORT BUSH 07	1
19	77306019000	FASTEN. DEVICE FILTER S. SX 07	1
26	77006026100	CABURETOR CONNECTING 07	1
27	78006027000	HOSE CLAMP 45-65MM	1
51	0017060204	EJOT PT SCREW K60X20 ALU WS=6	x
52	0017060203	EJOT PT SCREW K60X20 WS=6	1
79	77304066050	BUSHING F. CHAIN SLIDING PR.07	2

087800613 / C097800610

\* NEW PART

X AS REQUIRED

# TANK, SEAT, COVER

250 EXC-F EU 2010

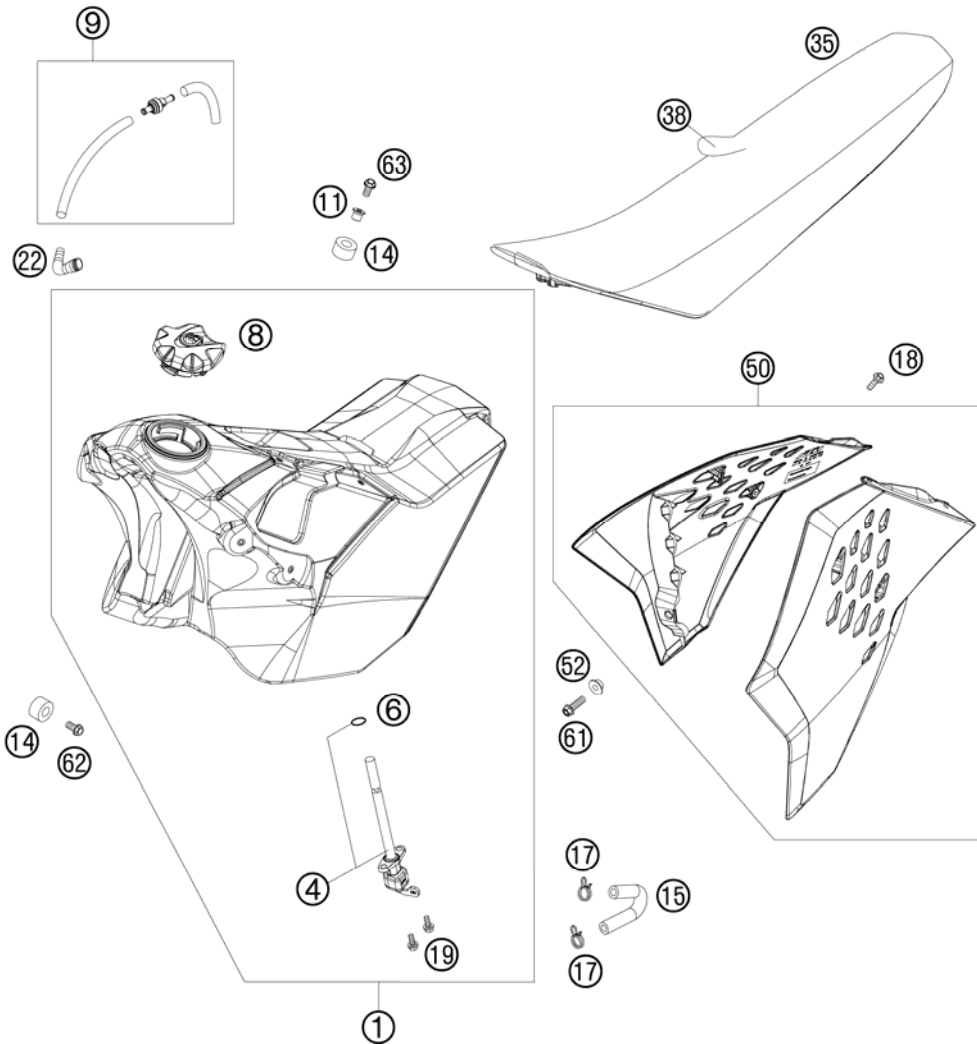

FIG	PART NUMBER	DESCRIPTION	QTY
1	7700721306630	FUEL TANK CPL. 9,5L EXC 08	1
4	78007004000	GAS COCK ON/OFF/RES 08	1
6	0770110021	O-RING 11X2 VITON	1
8	7800700804404	TANK PLUG ORANGE/BLACK	1
9	78007029000	TANK BREATHER HOSE + VALVE	1
11	77307026000	TANK BUSHING 07	1
14	50307014000	TANK ROLLER 12X26X12 '98	3
15	59007016000	FUEL HOSE 7,5X13MM	1
17	58031005000	CLAMP YDNAC 10128 12MM	2
18	0017060204	EJOT PT SCREW K60X20 ALU WS=6	8
19	0017060203	EJOT PT SCREW K60X20 WS=6	2
22	51030022000	ANGLE PIECE 90 DEGREE M10X1	1
35	77307040000	SEAT SX 07	1
38	77307040050	SEAT COVER 07	1
50	7730805410030D	SPOILER KIT BLACK EXC 09 WITH DECAL	1
52	50308052000	BUSH FOR SPOILER 6X11X16X5 MM	2
61	0025060206	HH COLLAR SCREW M6X20 TX30	2
62	0025060126	HH COLLAR SCREW M6X12 TX30	1
63	0024060273	COLLAR SCREW M6X27 TX	1

097800713 / C097800713

\* NEW PART

X AS REQUIRED

# MASK, FENDERS

250 EXC-F EU 2010

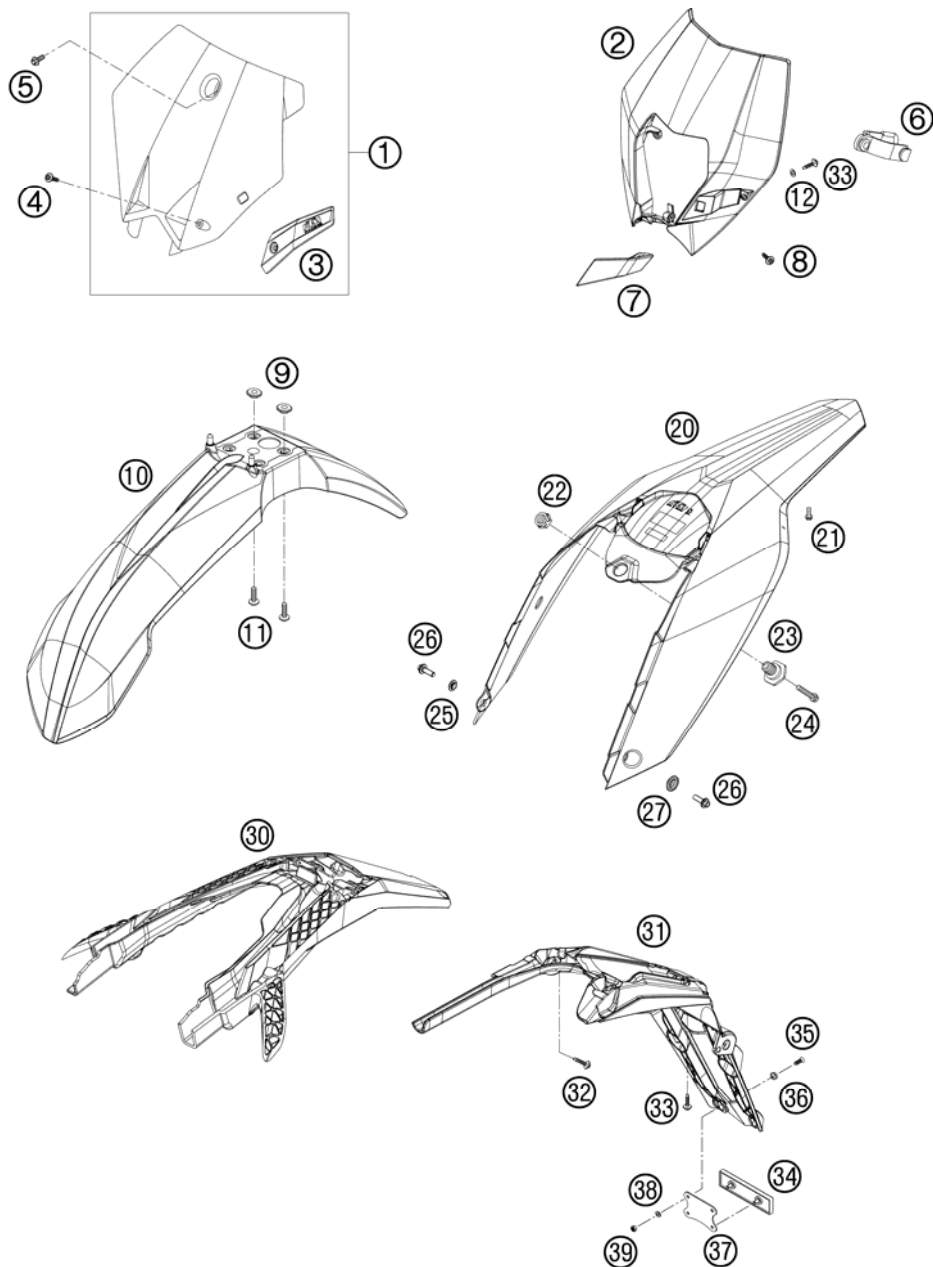

FIG	PART NUMBER	DESCRIPTION	QTY
1	7730800704404	START NUMBER PLATE ORANGE 07	1
2	7800800100004	HEAD LIGHT MASK ORANGE 08	1
3	7730802200004	BRAKE HOSE GUIDE ORANGE 07	1
4	0017060204	EJOT PT SCREW K60X20 ALU WS=6	2
5	0024060106	HH COLLAR SCREW M6X10 TX30	1
6	50211086000	MASK RUBBER UFO WP '95	2
7	7800802200004	BRAKE HOSE GUIDE ORANGE 08	1
8	0081500181	SCREW FOR PLASTIC D=5X18	3
9	54808020000	SPACER BUSHING 03	4
10	7730801000004	FRONT FENDER 07	1
11	0024060206	HH COLLAR SCREW M6X20 TX30	4
12	0125060003	WASHER DIN0125-A 6,4	1
15	77306001030	COLLAR BUSHING 4,5/12,6/23	1
20	7800801300004	REAR PART EXC ORANGE 08	1
21	0025050206	HH COLLAR SCREW M5X20 TX30	2
22	50314057050	COLLAR NUT M12X1/WS17 H=5MM	1
23	54807048000	BUSHING FOR SEAT FASTENING 03	1
24	0025060256	HH COLLAR SCREW M6X25 TX30	1
25	50308052000	BUSH FOR SPOILER 6X11X16X5 MM	1
26	0025060206	HH COLLAR SCREW M6X20 TX30	2
27	77306001030	COLLAR BUSHING 4,5/12,6/23	1
30	78008016000	NUMBER PL. CARRIER TOP PART 08	1
31	78008016050	NUMBER PL. CARRIER LOW PART 08	1
32	0017060303	SPECIAL SCREW T60 6X30 WS=6	2
33	0017060203	EJOT PT SCREW K60X20 WS=6	3
34	58412080000	REFLECTOR RED LC4 '98	1
35	0966050203	OVAL HEAD SCREW DIN0966-M 5X20	2
36	40006006000	WASHER 6MM	2
37	58412080050	BRACKET FOR REFLECTOR	1
38	0125050003	WASHER DIN0125-A 5,3	2
39	0985050003	SELF LOCKING NUT DIN0985-M 5	2

095030810 / C095030811

\* NEW PART

X AS REQUIRED

FIG	PART NUMBER	DESCRIPTION	QTY
2	77008291100	DISPLACEME.STICKER 250EXC-F 09	1

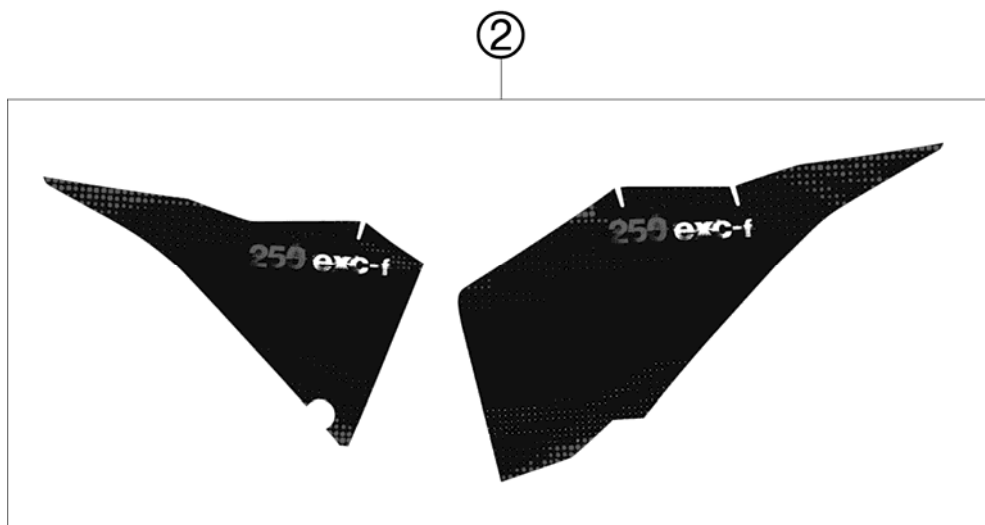

097800832 / C097800832

\* NEW PART

X AS REQUIRED

# FRONT WHEEL

250 EXC-F EU 2010

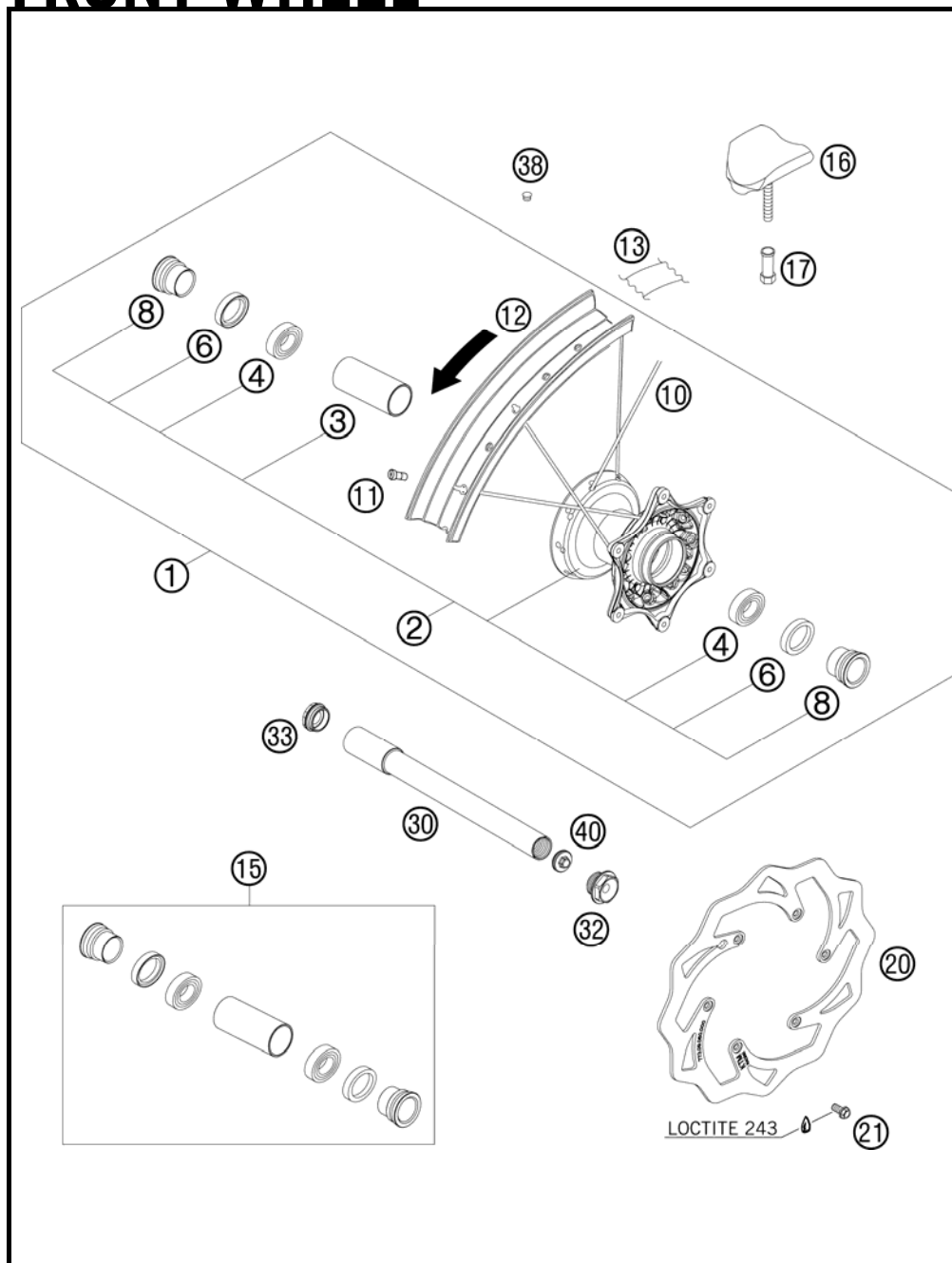

FIG	PART NUMBER	DESCRIPTION	QTY
1	7800900114430	FRONT WHEEL CPL.1,6X21"EXC. 09	1
2	78009010044	FRONT WHEEL HUB CPL. 08	1
3	54809011000	BEA.SPACERTUBE 35X2 L=79,4 03	1
4	0625069068	GR.BALL BEAR.6906 DDU2CG23S6NM	2
6	0760354771	SHAFT SEAL RING 35X47X7 TC	2
8	78009012000	SPACER BUSHING F. FR. WHEEL 08	2
10	78009174226	SPOKE M4,5x226-21" 08	36
11	50309072100	SPOKE NIPPLE M4,5X0,75 8X21	36
12	5480907000030	FRONT RIM 1,6X21" EXCEL AL7	1
13	50309073000	RIM BAND 21"	1
15	78009015000	FRONT WHEEL REP. KIT	x
16	51009100100	RIM LOCK VM1 (1,60")	1
17	50310090050	NUT FOR WHEEL HOLDER '96	1
20	77309060000	BRAKE DISC FRONT 260	1
21	59009062013	SPECIAL SCREW M6X13 WS=8 10.9	6
30	77309081000	WHEEL SPIN.FR. D=26 M24x1,5 07	1
32	54809082000	SPINDLE SCREW M24X1,5 WS=27 03	1
33	54809081050	PLUG BUSHING WS=27 03	1
38	55003135000	PLUG FOR RIM	x
40	54809081070	AUXILIARY SCREW FRONT 06	1

085230910 / C107800910

\* NEW PART

X AS REQUIRED

# REAR WHEEL

250 EXC-F EU 2010

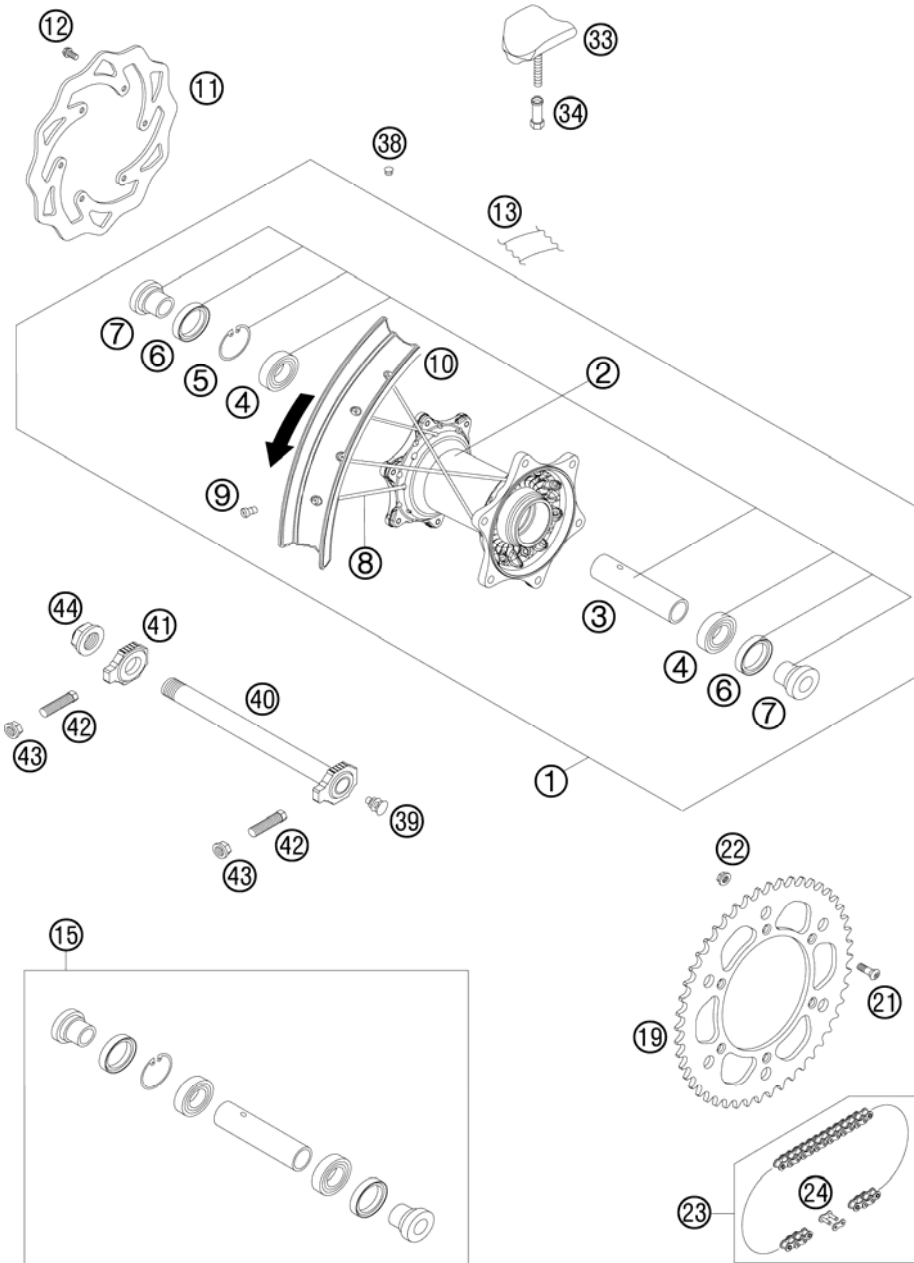

FIG	PART NUMBER	DESCRIPTION	QTY
1	7801000114430	REAR WHEEL CPL. 2,15X18"EXC.09	1
2	78010010044	REAR HUB CPL. 08	1
3	59010011000	BUSHING SPACER TUBE 121,5MM 01	1
4	0625060058	GR.BALL BEAR.6005 DDU2CG23S6NM	2
5	0472047175	CIRCLIP DIN0472-47X1,75	1
6	0760324771	SHAFT SEAL RING 32X47X7 BSL	2
7	78010016000	BUSHING FOR HUB 08	2
8	78010174193	SPOKE M5X193- 18"	36
9	58309072100	SPOKE NIPPLE M5-TA 8X21MM	36
10	5481007000030	REAR RIM 2,15X18" EXCEL AL7	1
11	77310060000	BRAKE DISC REAR 220	1
12	59009062013	SPECIAL SCREW M6X13 WS=8 10.9	6
13	50310073200	RIM BAND 18" AND 19"	1
15	78010015000	REAR WHEEL REP. KIT	x
19	58310051038	REAR SPROCKET 38-T	x
19	58310051042	REAR SPROCKET 42-T	x
19	58310151040	REAR SPROCKET 40-T	x
19	58310151045	REAR SPROCKET 45-T	x
19	58310151048	REAR SPROCKET 48-T	x
19	58310151049	REAR SPROCKET 49-T	x
19	58310151050	REAR SPROCKET 50-T	x
19	58310151051	REAR SPROCKET 51-T	x
19	58310151052	REAR SPROCKET 52-T	x
21	0019080266S	COUNTER-SUNK SCREW ISA45 M8X26	6
22	54310086200	SELF LOCKING NUT M8 10.9	6
23	50310165118	CHAIN 5/8X1/4" MX	1
23	50310800118	CHAIN Z-RING 5/8X1/4" REGINA	1
24	50310166000	CONNECTING LINK F. 50310165118	1
24	50310366000	CONNECTING LINK F. 50310800118	1
24	50310866000	MASTER LINK FOR 50310800118	1
33	54010100100	RIM LOCK VM3 (2.15")	2
34	50310090050	NUT FOR WHEEL HOLDER '96	2
38	55003135000	PLUG FOR RIM	x
39	50210086000	COVERING CAP SFL16	x
40	77310085044	WHEEL SPINDLE RE. CPL.265MM 07	1
41	50310084000	CHAIN TENSIONER R/S 2000	1

085481010 / C105031011

\* NEW PART

X AS REQUIRED

# REAR WHEEL

250 EXC-F EU 2010

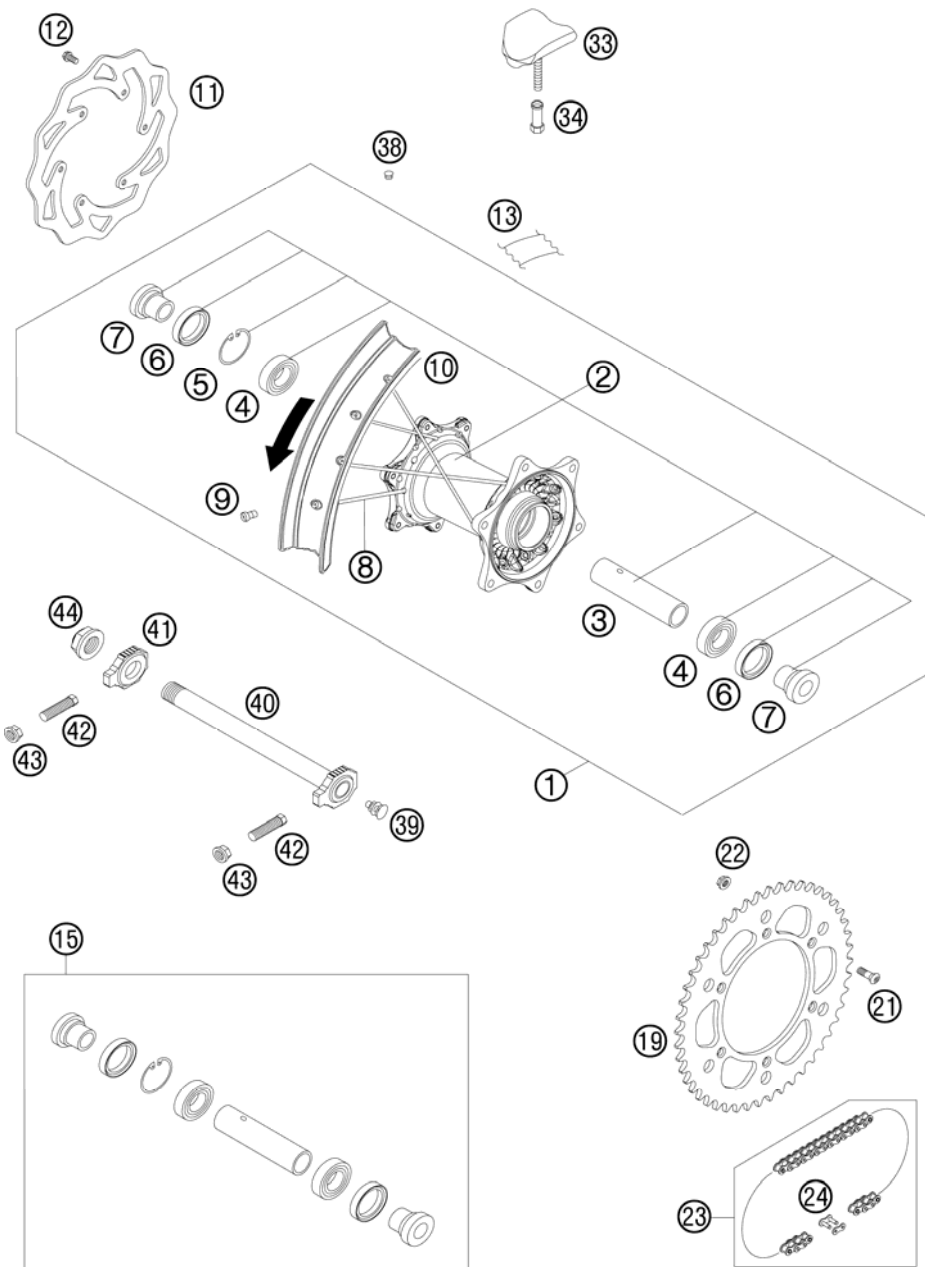

FIG	PART NUMBER	DESCRIPTION	QTY
42	50304040100	SCREW M10X1,25X50 WS=10	2
43	58414030000	HH COLLAR NUT M10X1,25 WS=13	2
44	50310099000	HEXAGON NUT M20X1,5 '98	1

085481010 / C105031011

\* NEW PART

X AS REQUIRED

# WIRING HARNESS

250 EXC-F EU 2010

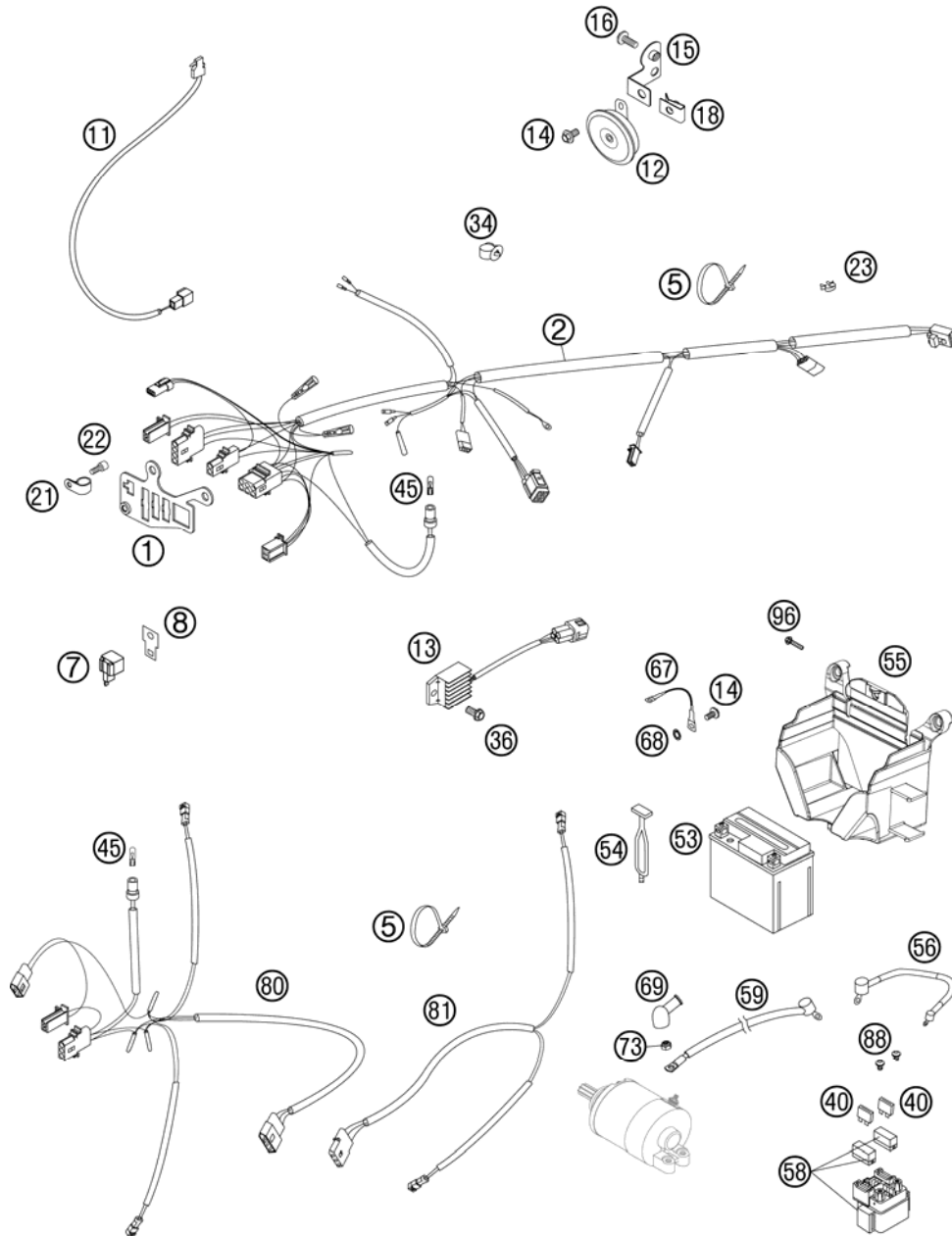

FIG	PART NUMBER	DESCRIPTION	QTY
1	54811083100	SUPPORT BRACKET EXC 2005	1
2	59411075150	WIRING HARNESS 250-525EXC EU06	1
5	44011076200	CABLE TIE 200/3,6MM BLACK	x
5	44011076305	CABLE TIE 300/4,8MM BLACK	x
7	44611207200	FLASHER UNIT 97	1
8	58211031100	BRACKET FOR FLASHER RELAISE	1
11	50311050100	BRAKE LIGHT SWITCH FRONT 2002	1
12	50311060200	DC HORN 12V 07	1
13	80011034000	VOLTAGE REGULATOR 04	1
14	0024060106	HH COLLAR SCREW M6X10 TX30	2
15	78011061000	HORN BRACKET EXC 08	1
16	0024060156	HH COLLAR SCREW M6X15 TX30	1
18	54603048100	RANGE CHANGE METAL NUT M6	1
21	57013070000	PVC-CLAMP 7/16" HEYCO 3377	1
22	0912050083	AH SCREW DIN 912 M 5X8	1
23	57013072000	WIRING HOLDER 12MM	x
23	57013072100	WIRING HOLDER 16MM	x
34	58111076000	CABLE SUPPORT KHS NR.150-47610	1
36	0025060126	HH COLLAR SCREW M6X12 TX30	1
40	58011109110	FUSE 10 A 2000	2
45	49111425000	BULB 12V 1,2W (W2X4,6D)	2
53	58511053000	BATTERY 12V 4AH YTX5L-BS	1
54	50303018000	RUBBER L=145MM	2
55	78011055000	BARRERY CASING	1
56	58711086000	WIRING HARNESS BATTERY DUKE'99	1
58	58211058000	STARTER RELAY 12V '99	1
59	55111059000	STARTERCABLE 1100MM 07	1
67	58411097100	GROUND CABLE D=6MM L=140MM '97	1
68	58411098100	CONTACT WASHER M6 VSV-K6	1
69	58440099000	PROTECTION CAP F. STARTER ENG.	1
73	0985060003	SELF LOCK. NUT DIN0985-M 6	1
80	59011080100	FLASH. WIRINGHARNESS FRONT 06	1
81	59011081100	FLASH. WIRINGHARNESS REAR 06	1
88	0902060083	AH OVAL SCREW ISO 7380 M 6X8	2
96	0017060204	EJOT PT SCREW K60X20 ALU WS=6	3

087801113 / C097801111

\* NEW PART

X AS REQUIRED



# HAND BRAKE CYLINDER

250 EXC-F EU 2010

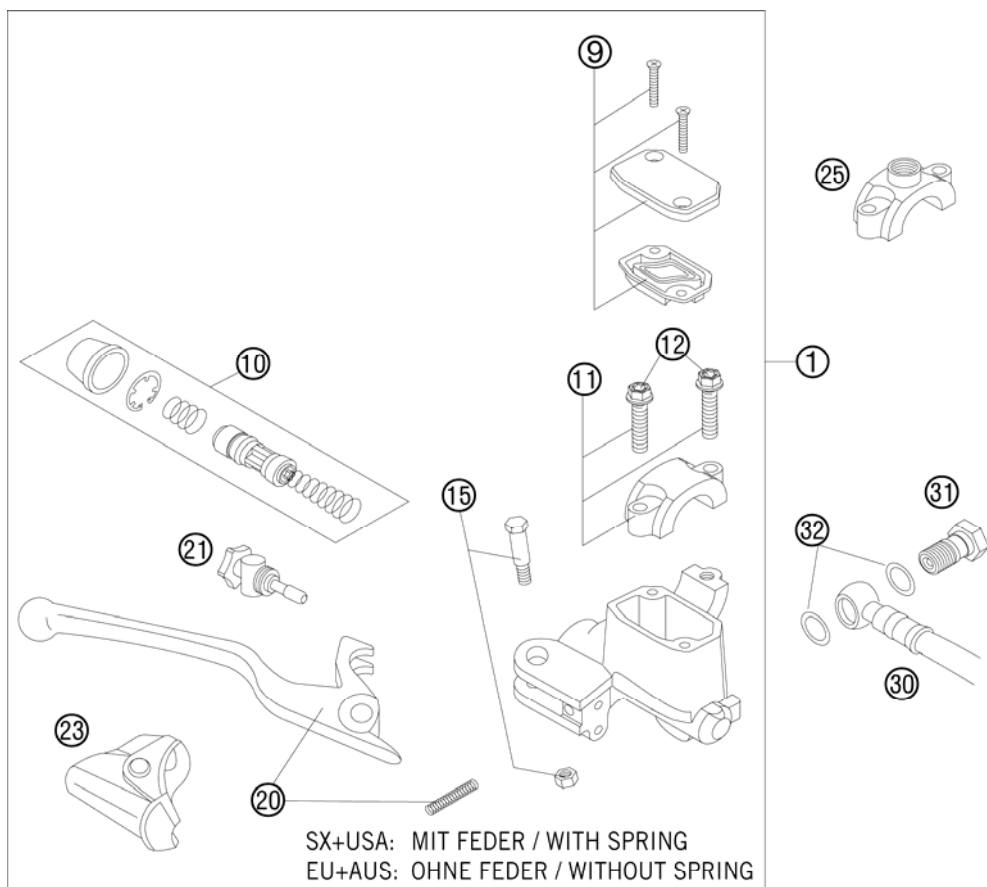

FIG	PART NUMBER	DESCRIPTION	QTY
1	54813001300	HAND BRAKE CYLINDER CPL.EXC 06	1
9	50313003000	HANDBRAKE CYL.COVER CPL.NATURE	1
10	54813008200	REP.SET PISTON D=10MM 2006	1
11	50313005000	CLAMP CPL. NATURE	1
12	0025060256	HH COLLAR SCREW M6X25 TX30	2
15	50313006100	LEVER SCREW CPL. 2001	1
20	54813002100	HAND BRAKE LEVER + SPRING 2006	1
21	54813007200	ADJUSTING SCREW CPL. EXC 2006	1
23	50313004000	PROTECTION CAP HAND BRAKE CYL.	1
25	58012040150	CLAMP FOR MIRROR '94	x
30	59013011000	BRAKEHO. FRONT 1300MM 2000	1
31	50213025000	HOLLOW SCREW M10X1X19	1
32	0603100141	COPPER GASKET DIN7603-10X14X1	2
80	00062030000	BRAKE FLUID DOT5.1 0,25L	1

085481300 / C095031311

\* NEW PART

X AS REQUIRED

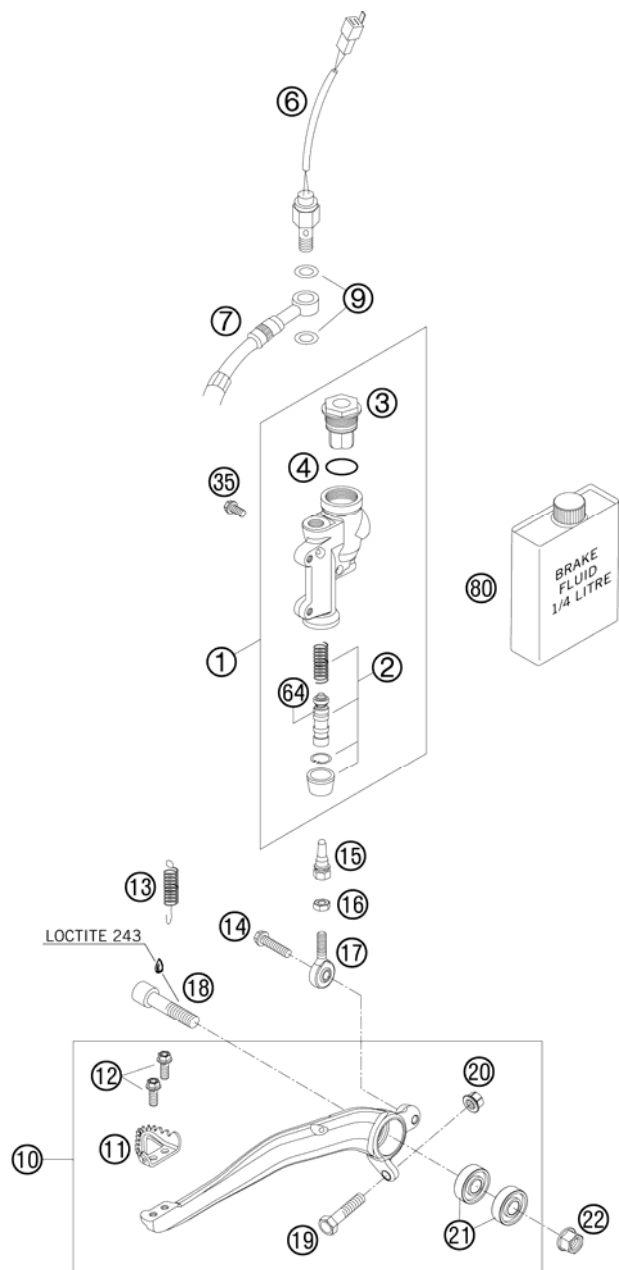

FIG	PART NUMBER	DESCRIPTION	QTY
1	54813060100	REAR BRAKE CYLINDER CPL. 2004	1
2	54813061200	REPAIR KIT PISTON 13MM 06	1
3	54813062100	REAR BRAKE CYL. COVER CPL. 04	1
4	54813063000	FOOT-BRAKE CYL. GASKET SX 03	1
6	50311051100	BRAKE LIGHT SWITCH REAR '98	1
7	54813070000	BRAKE HOSE REAR 655MM 03	1
9	0603100141	COPPER GASKET DIN7603-10X14X1	2
10	77313050044	FOOT BRAKE LEVER CPL. 07	1
11	54813051000	STEP PLATE FOR BRAKE LEVER	1
12	0025050126	HH COLLAR SCREW M5X12 TX30	2
13	54603062000	RETURN SPRING FOR BRAKE LEVER	1
14	0025060206S	HH COLLAR SCREW M6X20 TX30	1
15	54813056000	PUSH ROD L=28MM 03	1
16	0985060003	SELF LOCK. NUT DIN0985-M 6	1
17	54813055000	SWIVEL HEAD KA6 03	1
18	0912100406	AH SCREW DIN6912 M10X40 10.9	1
19	59001037000	SPECIAL SCREW M8X26 WS=10	1
20	46030045000	COLLAR NUT M8 WS=10	1
21	0625060002	BALL BEARING SKF 6000-2RS1	2
22	54630044000	COLLAR NUT M10 WS=13	1
35	0025060126	HH COLLAR SCREW M6X12 TX30	2
64	54813064200	BELLOWS FOR REPAIR KIT 06	1
80	00062030000	BRAKE FLUID DOT5.1 0,25L	1

085031331 / C095031331

\* NEW PART

X AS REQUIRED

# BRAKE CALIPER FRONT

250 EXC-F EU 2010

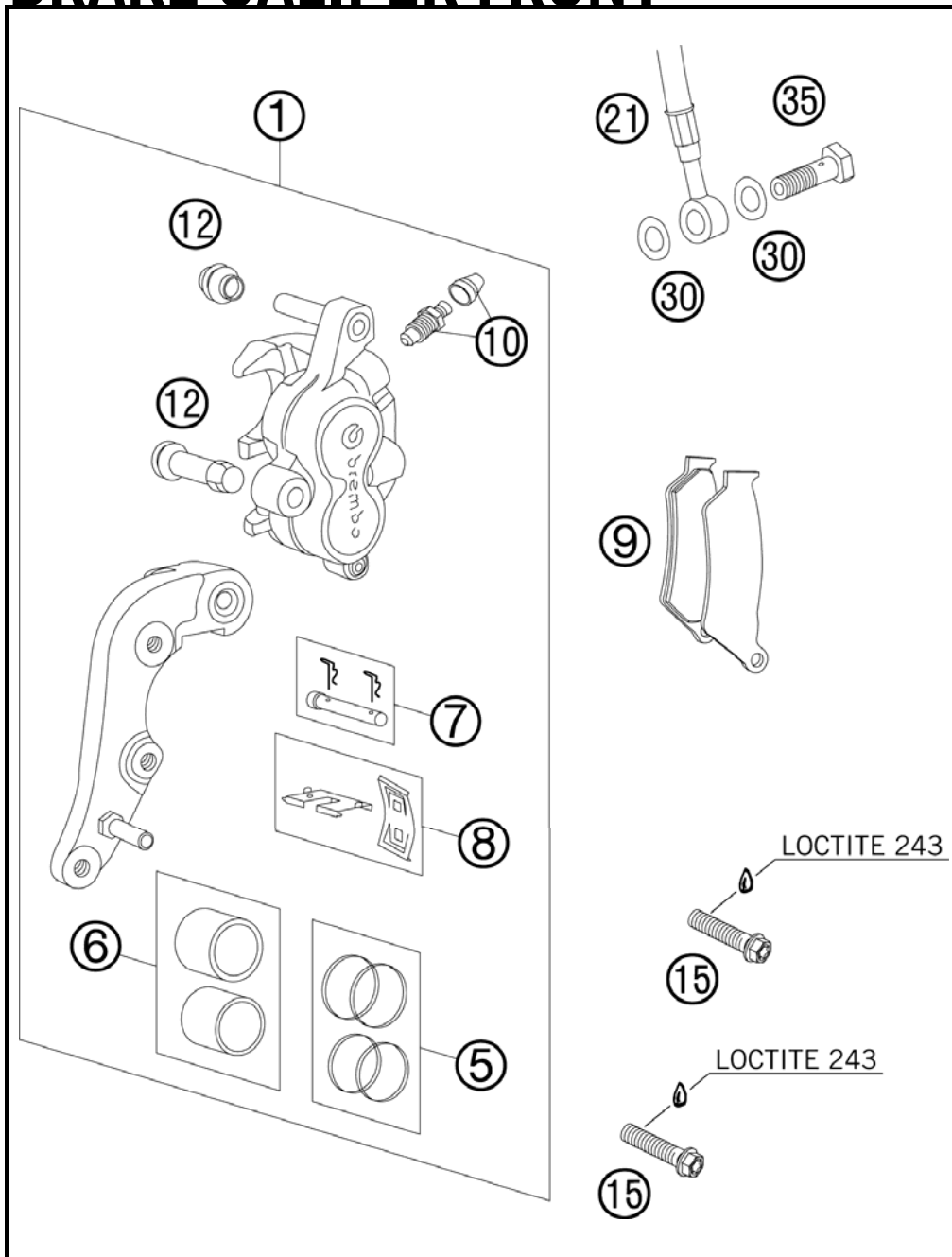

FIG	PART NUMBER	DESCRIPTION	QTY
1	59013015101	BRAKE CAL. FR. - WITHOUT PADS	1
5	54613205000	REPAIR KIT 28MM	1
6	54613206000	REPAIR KIT PISTON 28MM	1
7	54613210100	BOLT CPL. 6X56	1
8	54613212000	RETAINING PLATE SET BREMBO	1
9	50313030200	BRAKE.SET FR.TOSHIBA TT2701HH	1
10	60013020000	BLEEDER SCREW WITH CAP	1
12	54613218000	CUP SET SHORT	1
15	0025080356S	HH COLLAR SCREW M8X35 TX40	2
21	59013011000	BRAKEHO. FRONT 1300MM 2000	1
30	0603100141	COPPER GASKET DIN7603-10X14X1	2
35	50213025000	HOLLOW SCREW M10X1X19	1

095031360 / C095031360

\* NEW PART

X AS REQUIRED

# BRAKE CALIPER REAR

250 EXC-F EU 2010

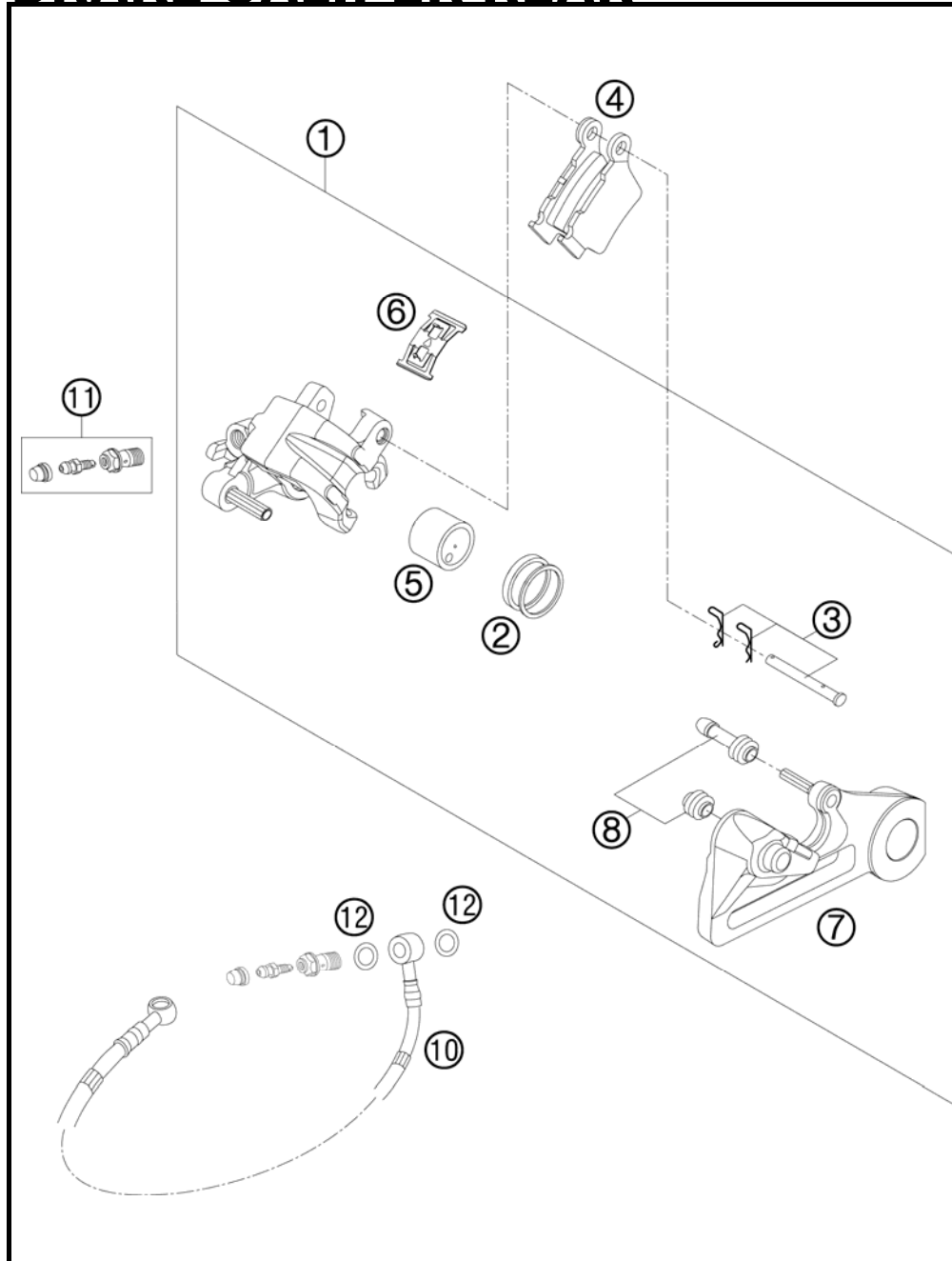

FIG	PART NUMBER	DESCRIPTION	QTY
1	54813080101	BRAKE CAL. RE. - WITHOUT PADS	1
2	50313081200	REPAIR KIT SEALING RINGS 26MM	1
3	54813082000	BOLT SET FOR BRAKE CALIPER 03	1
4	54813090300	BRAKE PAD SET REAR TOYO	1
5	54813083000	BRAKE PISTON 26MM 2003	1
6	54813018000	RETAINING SPRING SET 2003	1
7	54813075000	BRAKE CALIPER SUPPORT REAR	1
8	54613218000	CUP SET SHORT	1
10	54813070000	BRAKE HOSE REAR 655MM 03	1
11	62513020000	BLEEDER SCREW CPL. 05	1
12	0603100141	COPPER GASKET DIN7603-10X14X1	2

095031390 / C095031390

\* NEW PART

X AS REQUIRED

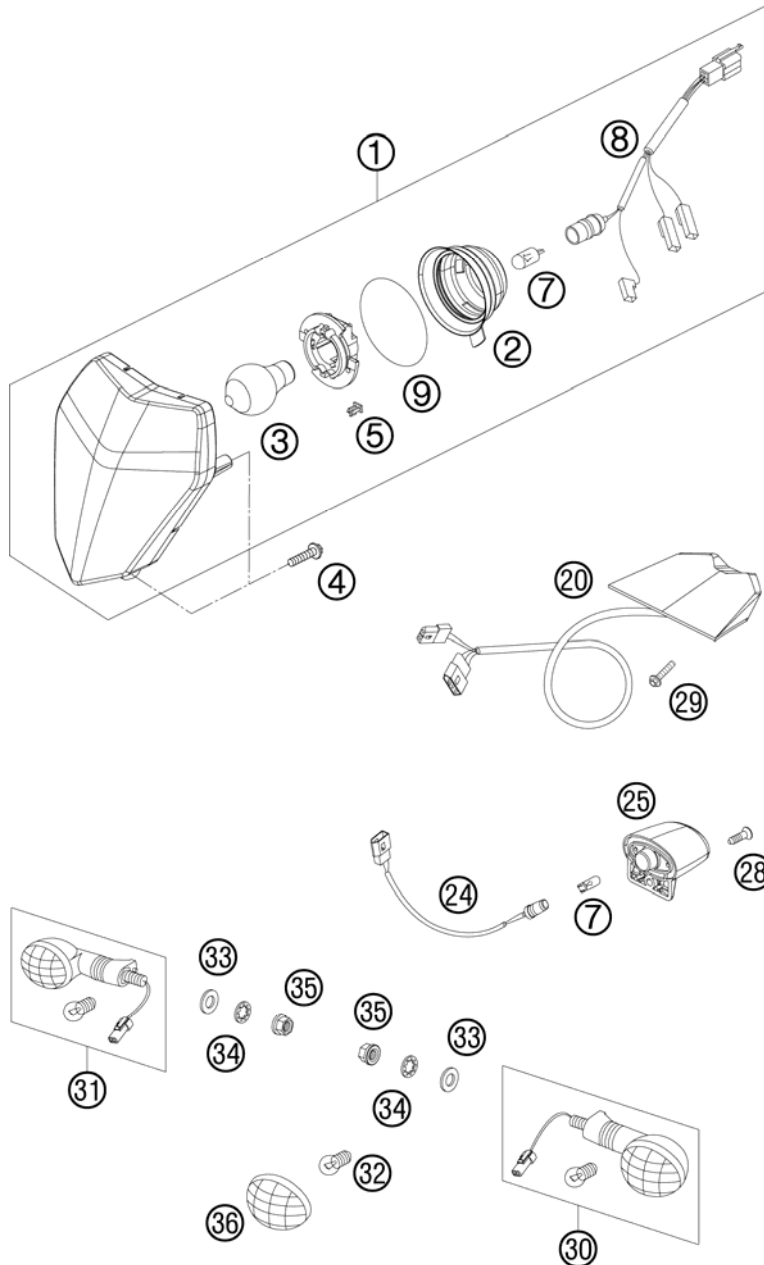

FIG	PART NUMBER	DESCRIPTION	QTY
1	78014001000	HEAD LIGHT CPL. EXC-EU 08	1
2	54814001050	RUBBER CAP FOR HEAD LIGHT 05	1
3	44111038000	BILUX-BULB 12V 35/35W BA20D	1
4	0081500181	SCREW FOR PLASTIC D=5X18	3
5	78014009000	DRAIN HOLE COVER	1
7	49011435100	BULB 12V 5W (W2,1X9,5D) PHIL.	2
8	54811001050	CABLE FOR HEAD LIGHT 2005	1
9	0770350032	O-RING 35,00X32,00 NBR	1
20	78014040000	REAR LIGHT EXC-EU 2008	1
24	78011093000	WIRING H. LICENSE PL. ILLUM.08	1
25	75014047000	LICENSE PLATE ILLUMINATION 07	1
28	0081250181	SCREW FOR PLASTIC 50X18 T20	1
29	0017060203	EJOT PT SCREW K60X20 WS=6	2
30	54814025100	FLASHER CPL.FRONT L/S REAR R/S	2
31	54814026100	FLASHER CPL. FRONT R/S REAR L/S	2
32	44111015100	BULB 12V 10W (BA15S)	4
33	0125100003	WASHER DIN0125-A10,5	4
34	0797100003	LOCK WASHER DIN6797-J10,5 ZI	4
35	58414030000	HH COLLAR NUT M10X1,25 WS=13	4
36	54814028000	FLASHER LENS L/S R/S 05	4

095031410 / C095031410

\* NEW PART

X AS REQUIRED

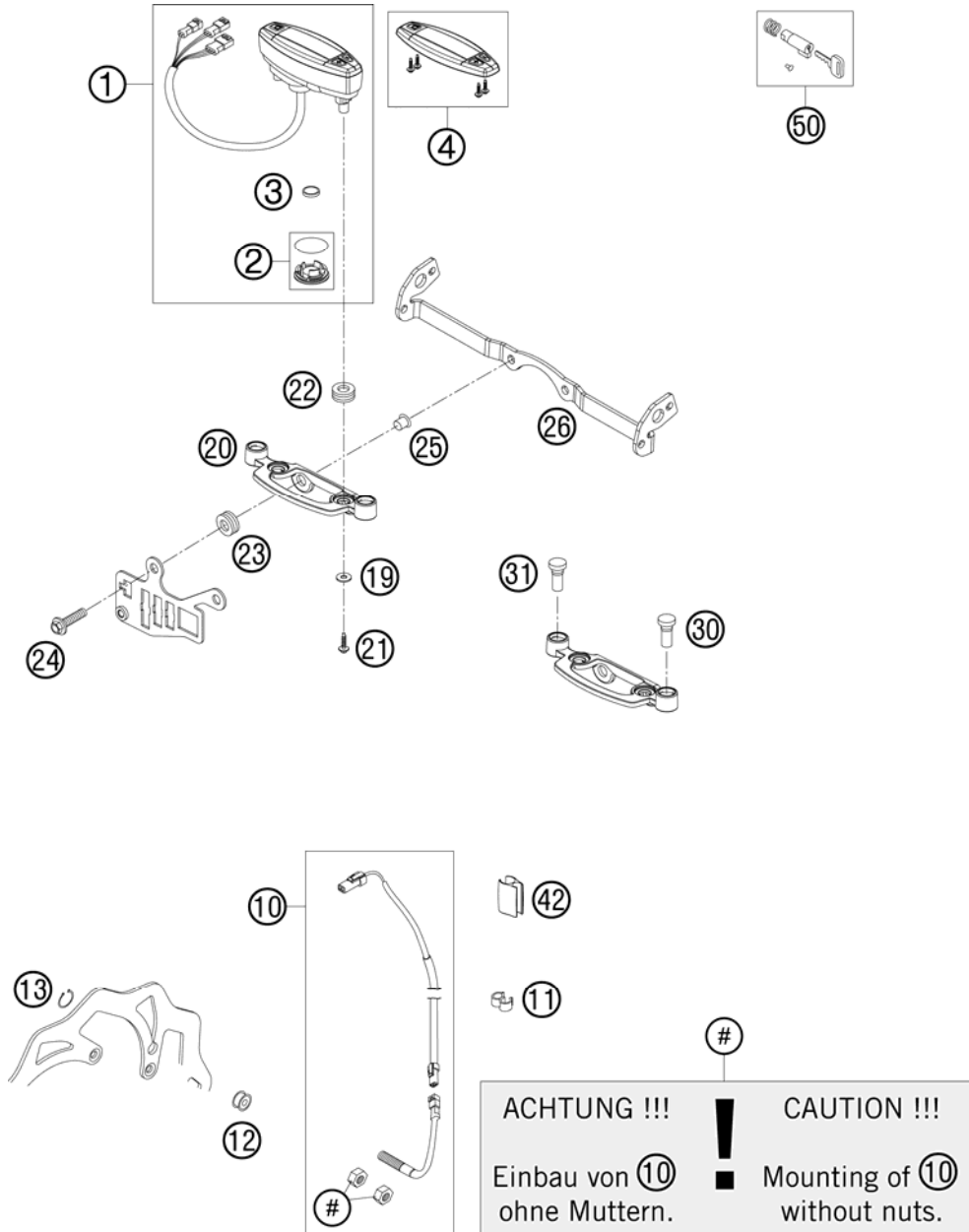

FIG	PART NUMBER	DESCRIPTION	QTY
1	54814069000	SPEEDOMETER KM/H F. 21" 2005 REPROGRAMMABLE: KM/H - MPH	1
2	54814069010	BATTERY COVER F. SPEEDOM. 2005	1
3	58314068000	BATTERY F. SPEEDOM. M.A.E. 02	1
4	54814069020	SPEEDOMETER TOP PART 05	1
10	54814068100	CABLE FOR DIGITAL SPEEDOM. 06	1
11	55011022100	CLAMP D=6/8MM, BLACK	3
12	54814069050	MAGNET FOR DIGITAL SPEEDOM. 03	1
13	0471009104	CIRCLIP DIN0471- 9X1 INOX	1
19	0021050003	WASHER DIN9021-A 5,3	2
20	54814060000	SPEEDOMETER BRACKET 05	1
21	0081050121	SCREW FOR PLASTIC K50X12 T20	2
22	58214069051	RUBBER GROMMET 16X10,8X3 02	2
23	31008060000	RUBBER SLEEVE D=8MM OPEN	2
24	0024060256	HH COLLAR SCREW M6X25 TX30	2
25	58314060050	SPACER BUSH. F. SPEEDOMET.BRA.	2
26	78014033000	FLASHER BRACKET EXC 08	1
30	58011021300	H.BEAM INDICATOR LIGHT BLUE'98	1
31	58011024300	FLASHER INDICAT.LIGHT GREEN'98	1
42	54813026000	CABLE SUPPORT 10/6MM 06	2
50	78003035000	STEERING HEAD LOCK 08	1

095031430 / C095031430

\* NEW PART

X AS REQUIRED

①  
OHNE ABBILDUNG  
WITHOUT ILLUSTRATION

①  
TECHNISCHE DOKUMENTATION  
TECHNICAL DOCUMENTATION  
DOCUMENTACION TECNICA  
DOCUMENTATION TECHNIQUE  
NOTE TECNICHE

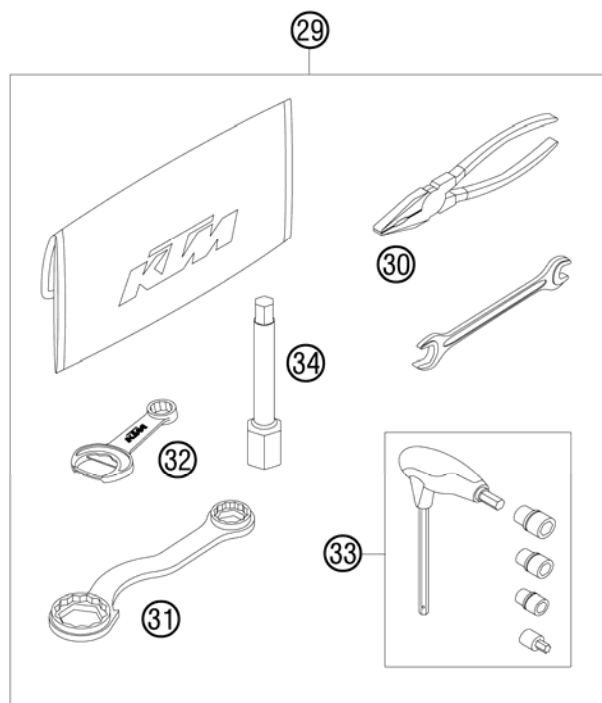
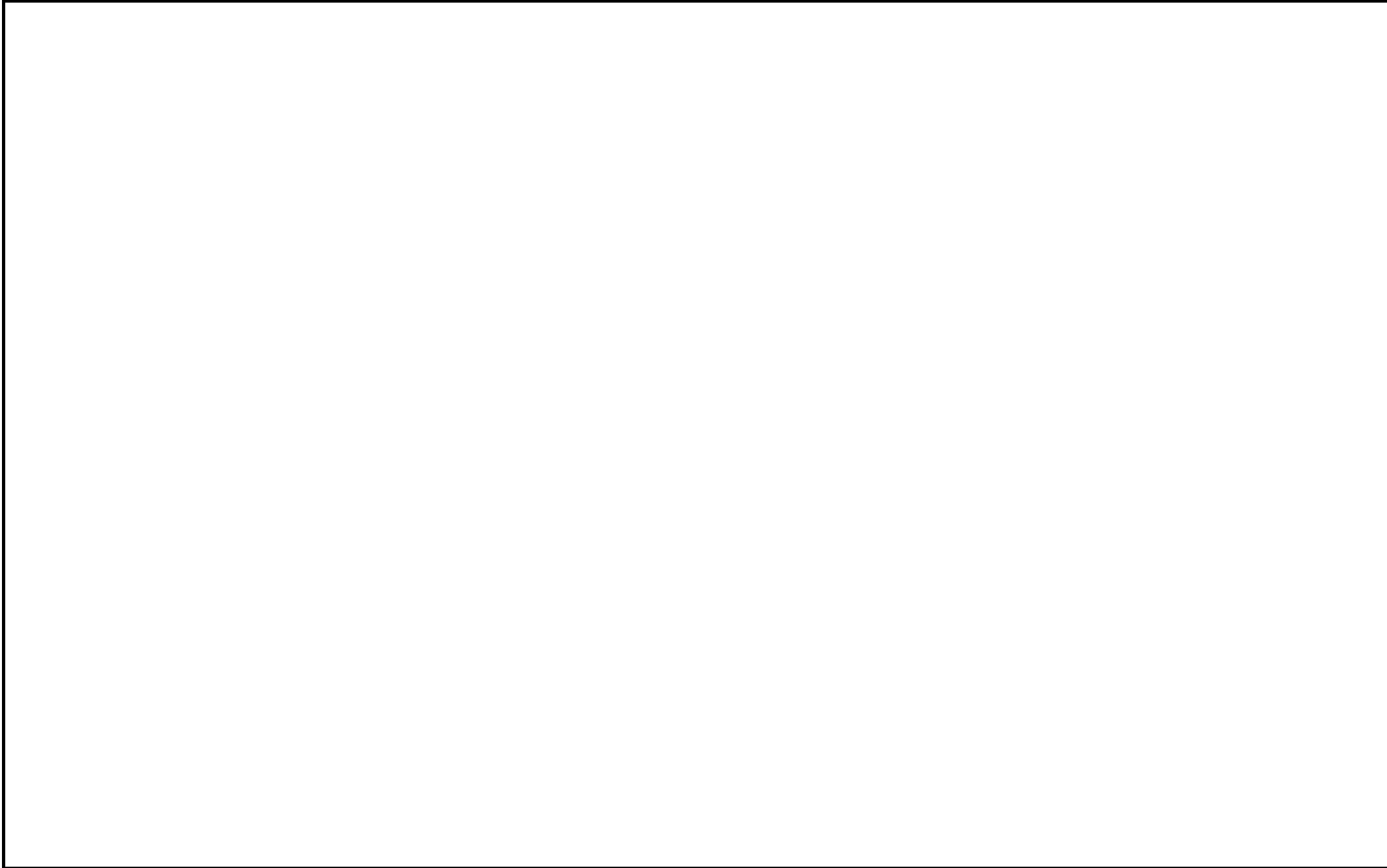

FIG	PART NUMBER	DESCRIPTION	QTY
0	0019080206S	FLAT HEAD SCREW M. ISA45 M8X20	1
0	0019080266S	COUNTER-SUNK SCREW ISA45 M8X26	6
0	0125050003	WASHER DIN0125-A 5,3	2
0	0966050203	OVAL HEAD SCREW DIN0966-M 5X20	2
0	0985050003	SELF LOCKING NUT DIN0985-M 5	2
0	312305	DOCUMENTS BAG 2006	1
0	312313	KTM BALLPOINT ORANGE	1
0	3210039	CUSTOMER WELCOME LETTER	1
0	40006006000	WASHER 6MM	2
0	50033029013	FRONT SPROCKET 13-T	1
0	50310900116	CHAIN X-RING 116 R	1
0	54310086200	SELF LOCKING NUT M8 10.9	6
0	58012040150	CLAMP FOR MIRROR '94	2
0	58310151050	REAR SPROCKET 50-T	1
0	58412040000	MIRROR L/S 98	1
0	58412040050	SUPPORT FOR MIRROR LC4 '98	2
0	58412041000	MIRROR R/S 98	1
0	58412080000	REFLECTOR RED LC4 '98	1
0	58412080050	BRACKET FOR REFLECTOR	1
0	58511053000	BATTERY 12V 4AH YTX5L-BS	1
0	77303094100	PLASTIC FRAME PROTECTION SET	1
0	77306016000	FILTER CARRIER 4S SX 07	1
0	78003040033	FOOTREST L/S + R/S CPL. 09	1
1*	3211481EN	OWNERS MAN 250SX/XC/EXC-F-W	1
1*	3CF8103J9EN	SPM CHASSIS 250 EXC-F EU 2010	1
1*	3CM089313JEN	SPM ENGINE 250 EXC-F 2010	1
29	77029099100	TOOL KIT 07	1
30	53012028200	GRIP ORANGE B&F	1
31	50329080100	WRENCH SW=17/21/27/32 B&F	1
32	50329071100	WRENCH WS=13 B&F + OPENER	1
33	60029070200	T-WRENCH WS=6/8/10 TX=45 B&F	1
34	77029072000	SPARK PLUG KEY 250 SX-F	1

087802001 / C107802003

\* NEW PART

X AS REQUIRED













KTM-Sportmotorcycle AG  
A-5230 Mattighofen  
[www.ktm.at](http://www.ktm.at)

KTM Group Partner



3CF8103J9EN



Art.Nr.: 3CF8103J9EN 1/2009