

990 Super Duke

turn signal , horn , fan

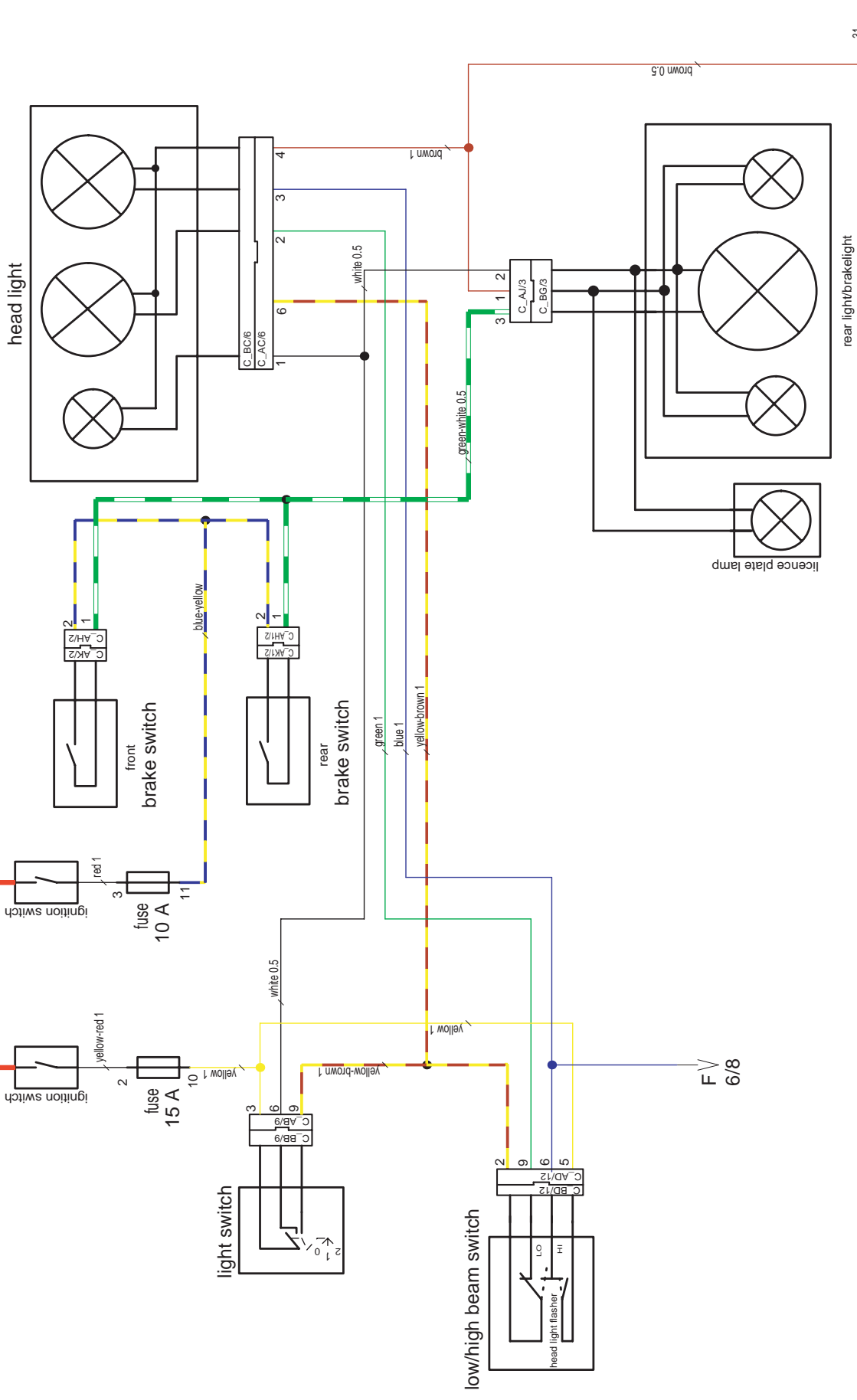

990 Super Duke

light-brake system

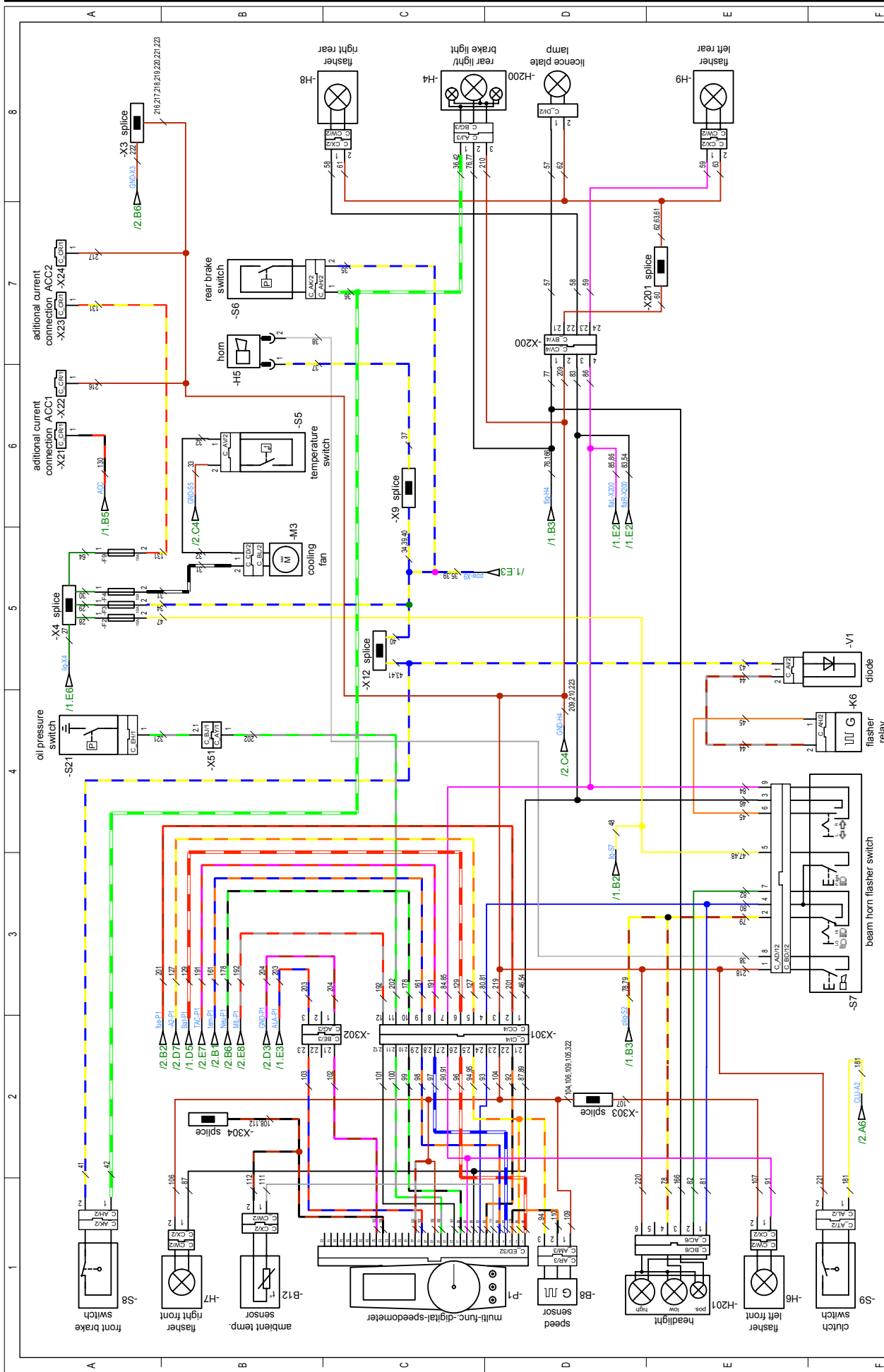

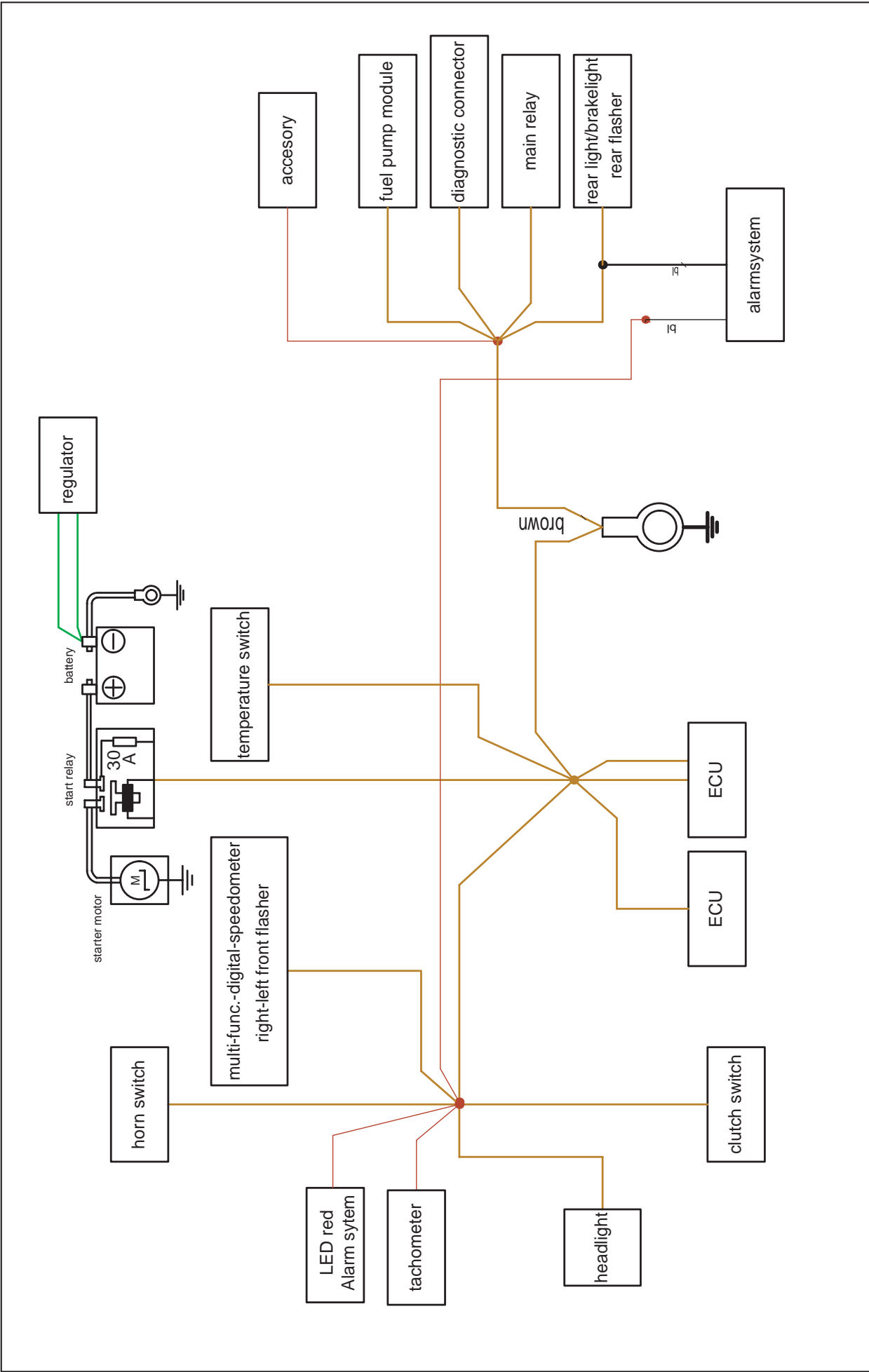

	<p>990 Super Duke</p>	<p>ground connection</p>	<p>7/8</p>
---	-----------------------	--------------------------	------------

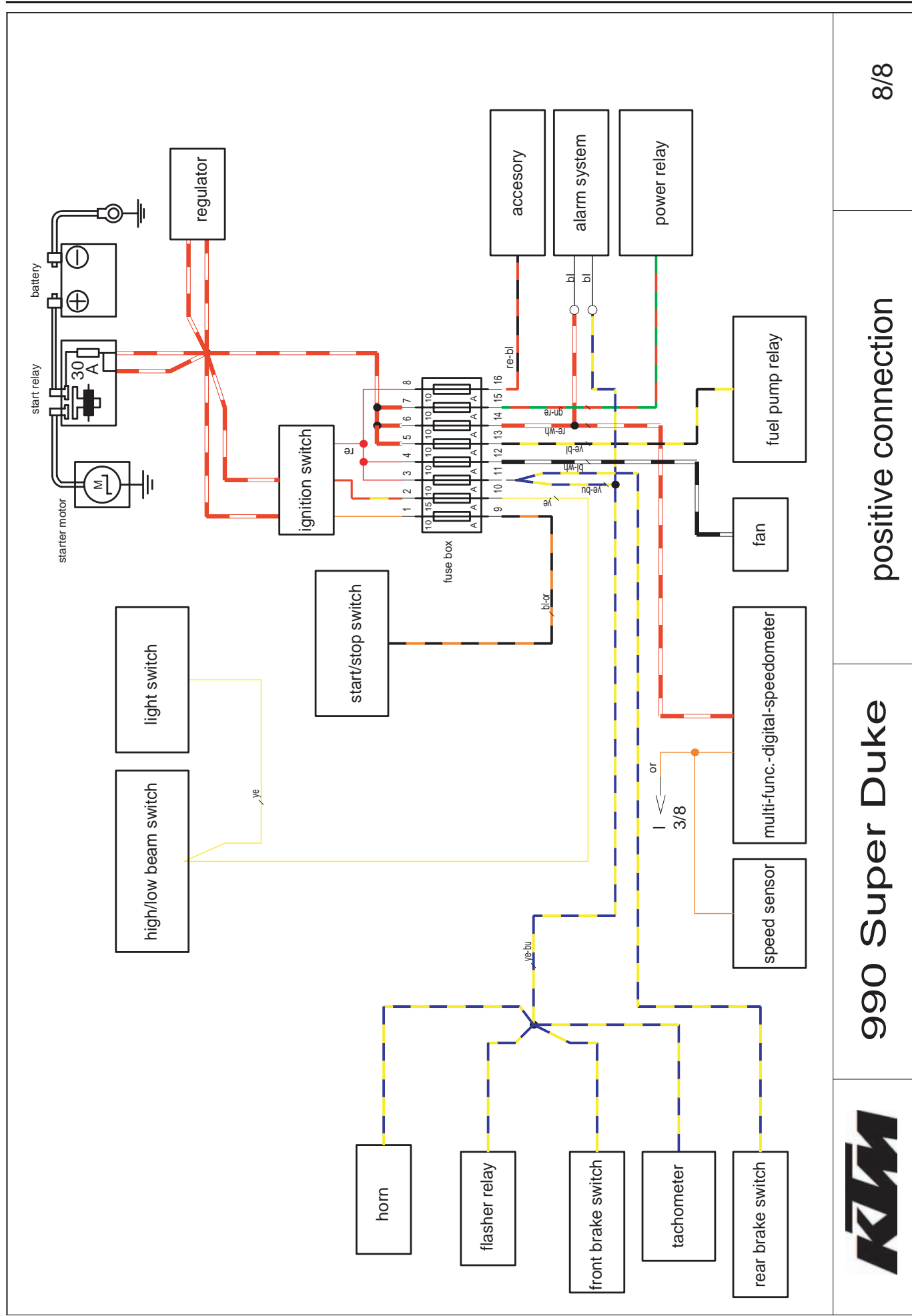

990 Super Duke

positive connection

NOTE to the connector designations:

The connector designations are comprised of letters and numbers - e.g.: **C_AA1/20**

- The 1st position **C** stands for connector (connector).
- The 2nd and 3rd positions **AA** stand for the connector type.
- The 4th position numbers the same type of connector if the connector is used for different applications.
- The 5th and 6th positions **20** specify the number of pins in the connector, in this case 20 poles. The 5th position is not required for connectors with less than 10 pins.

Cable colours

bl: black

ye: yellow

bu: blue

gn: green

re: red

wh: white

br: brown

or: orange

pi: pink

gr: grey

pu: purple